

Project
1 West Halkin

Drawing Title
LG Kitchen Cupboard Detail

Issue Date
22/11/23

Paper Scale
@ A3

Revision

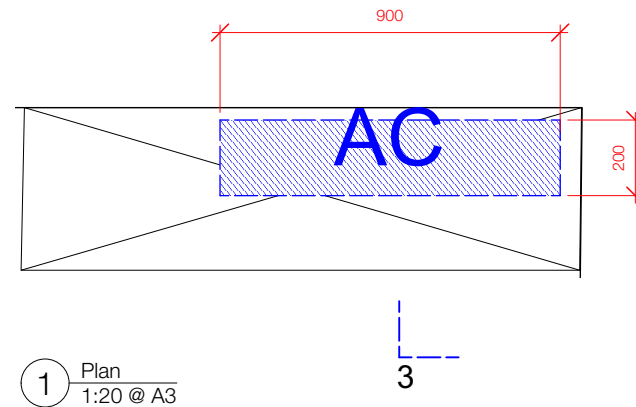

2 Elevation
1:20 @ A3

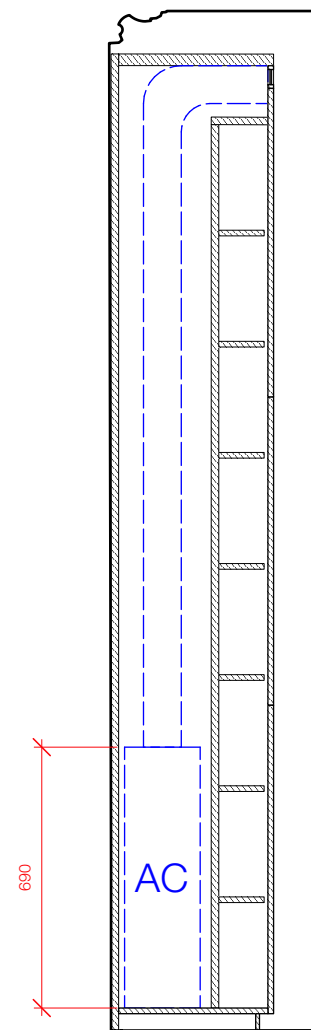

3 Section
1:20 @ A3

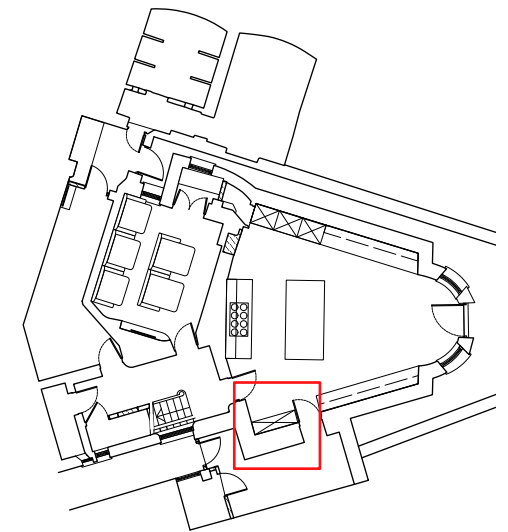

LOCATION PLAN
NTS

This drawing is for illustrative purposes only. All drawings are not for construction unless specifically marked for this purpose.

All dimensions to be checked on site. Any discrepancy to be verified with the Architect / Designer before proceeding with the works.

DESIGN & THAT
177 Victoria Park Road, E9 7JN
Phone +44 (0) 7891611379

www.designandthat.com
hello@designandthat.com

Project
1 West Halkin

Drawing Title
LG Cinema Aircon Housing Detail

Issue Date
22/11/23

Paper Scale
@ A3

Revision

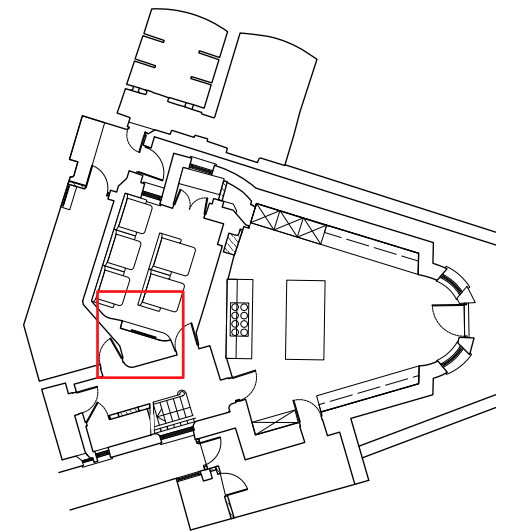

LOCATION PLAN
NTS

This drawing is for illustrative purposes only. All drawings are not for construction unless specifically marked for this purpose.

All dimensions to be checked on site. Any discrepancy to be verified with the Architect / Designer before proceeding with the works.

DESIGN & THAT
177 Victoria Park Road, E9 7JN
Phone +44 (0) 7891611379

www.designandthat.com
hello@designandthat.com

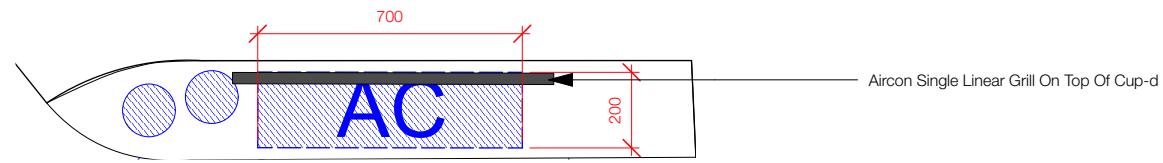

1 Plan
1:20 @ A3

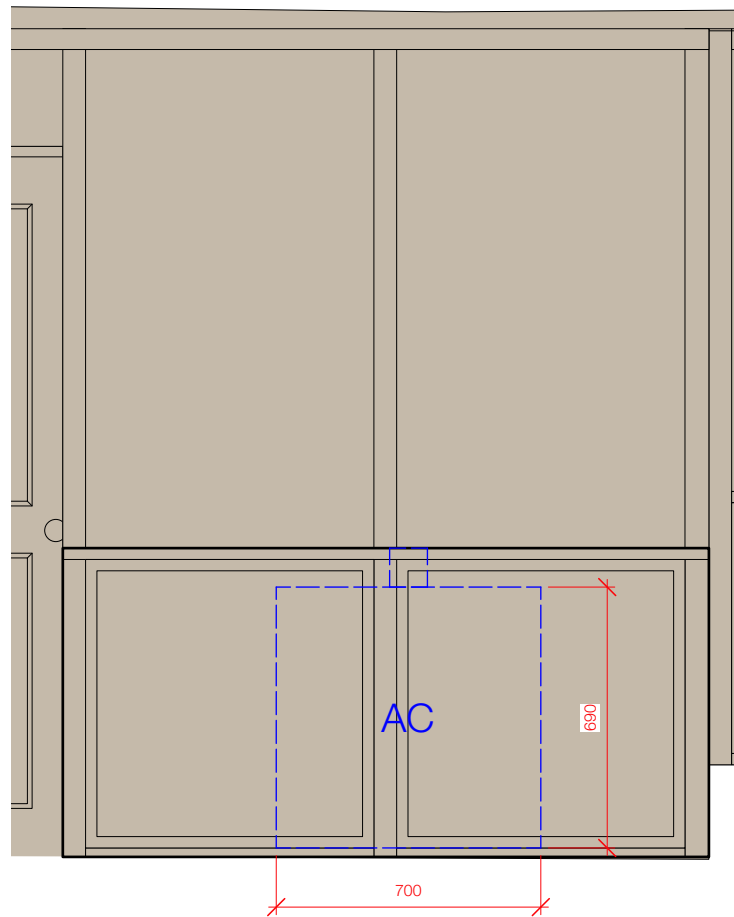

2 Elevation
1:20 @ A3

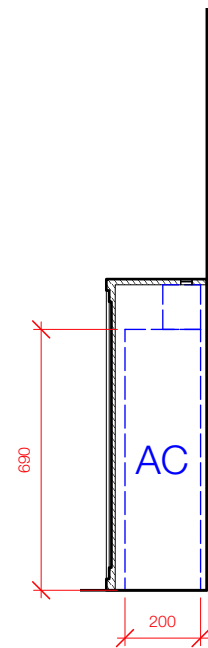

3 Section
1:20 @ A3

Project
1 West Halkin

Drawing Title
LG Gym Aircon Housing Detail

Issue Date
22/11/23

Paper Scale
@ A3

Revision

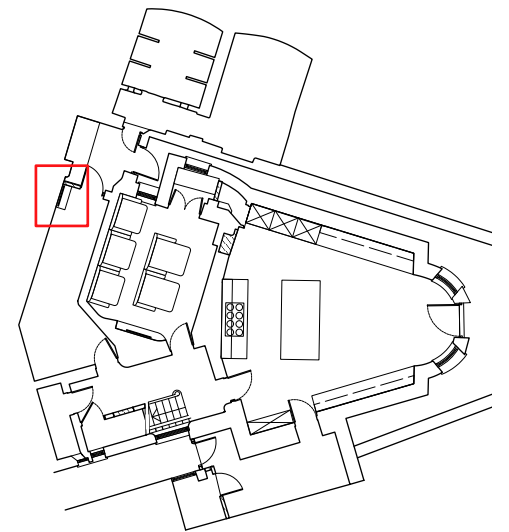

LOCATION PLAN
NTS

This drawing is for illustrative purposes only. All drawings are not for construction unless specifically marked for this purpose.

All dimensions to be checked on site. Any discrepancy to be verified with the Architect / Designer before proceeding with the works.

DESIGN & THAT
177 Victoria Park Road, E9 7JN
Phone +44 (0) 7891611379

www.designandthat.com
hello@designandthat.com

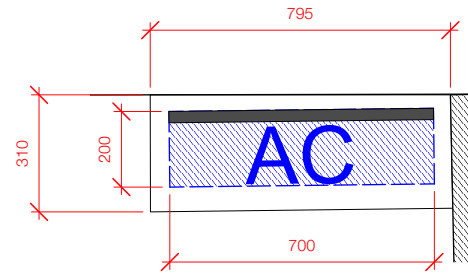

1 Plan
1:20 @ A3

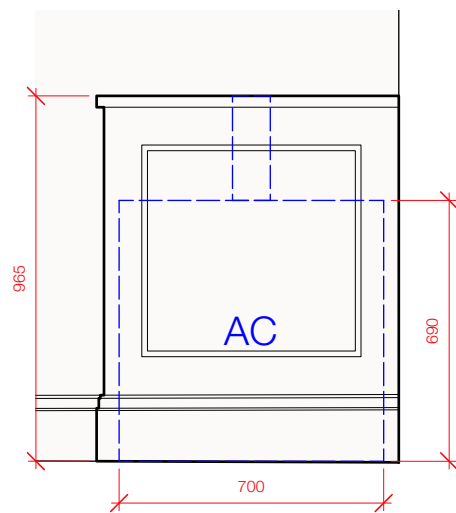

2 Elevation
1:20 @ A3

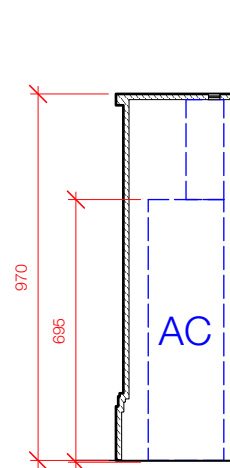

3 Section
1:20 @ A3