

# DOMESTIC WATER AND WASTEWATER TREATMENT SOLUTIONS



# UNRIVALLED PERFORMANCE

Marsh Industries delivers eco-friendly wastewater treatment products and solutions to the UK domestic sector from its manufacturing plants in Kettering, Raunds and Bridgwater.

We strive to be recognised as a collaborative and trusted partner to our customers, with a reputation for providing unrivalled products with unrivalled performance.

- Sewage treatment plants, septic tanks, septic conversion units, pump chambers and more

[www.marshindustries.co.uk](http://www.marshindustries.co.uk)



# What are your options?

Choosing the right sewage treatment and disposal method for your site is essential to ensure effective long-term performance, protection of public health and the environment, and compliance with relevant legislation.

Sewage treatment and disposal can be provided by either public (foul) sewer or by a private sewage system. Use of a private system is only usually acceptable where connection to the public sewer is not possible, and as such should be discussed with your local Planning Authority at an early stage.

Before sewage effluent can be discharged to 'controlled waters' it must receive at least primary and secondary treatment:

- For a discharge to ground the micro-organisms in the soil provide the secondary treatment
- For a discharge to a water course the sewage treatment must be provided by a Package Sewage Treatment Plant (PSTP) or equivalent

See page 22 for further guidance on sewage treatment.

## System selection

Hierarchy of off-mains discharge routes as laid out by the environmental regulators and British Water

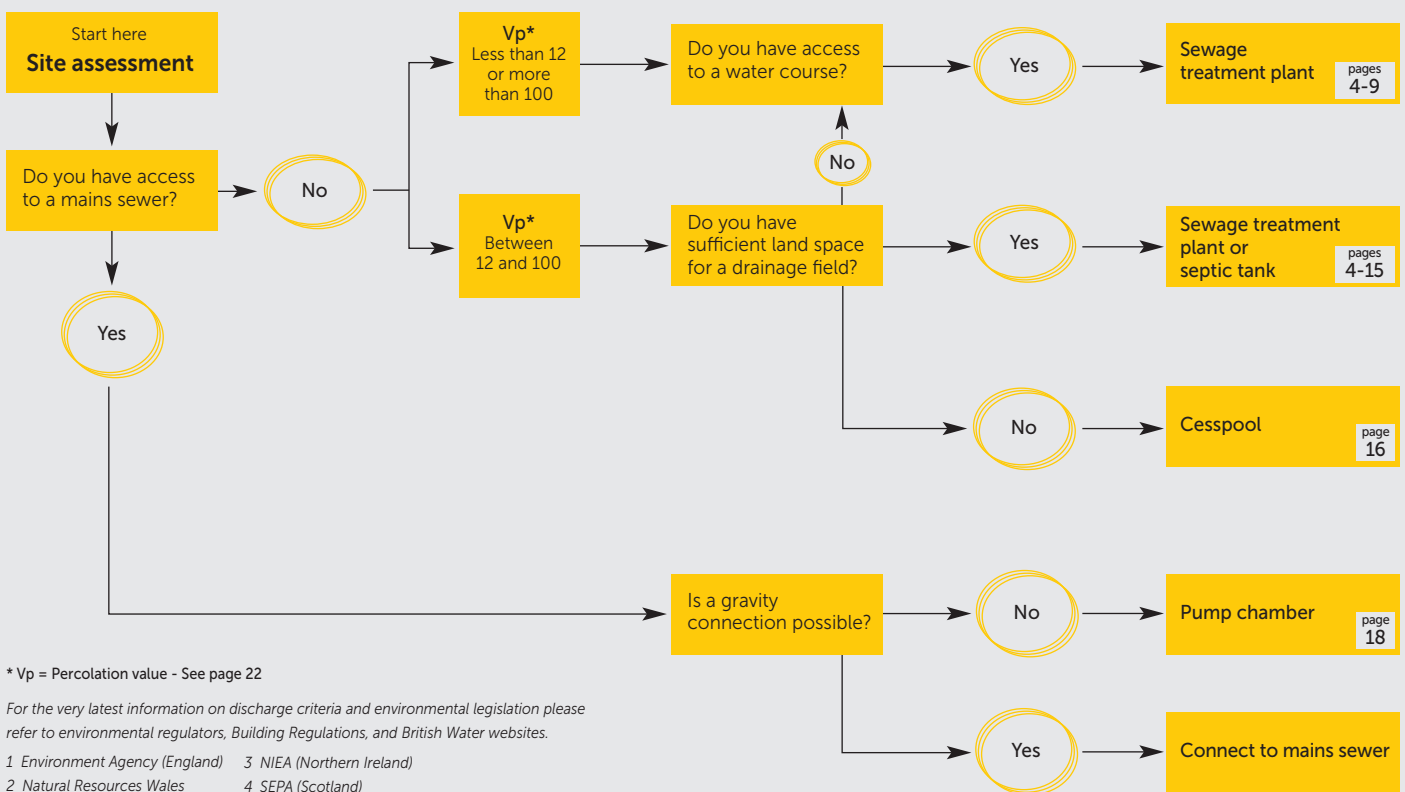

<p>GEM-APS Aerated Precipitation System Eco-friendly, economical phosphate and ammonia reduction</p> <p style="text-align: right;"><b>NEW</b></p> <p style="text-align: right;">page 10</p>	<p>Need to upgrade your existing septic tank? The Marsh Uni:Gem★ septic conversion unit may be a practical solution</p> <p style="text-align: right;">page 12</p>	<p>Noisy diaphragm compressors? The Marsh Whisspurr® acoustic vibration reduction unit eliminates noise and vibration</p> <p style="text-align: right;">page 17</p> 
---	---	---

# Ensign<sup>®</sup>

## Sewage treatment plants

Intensive biological processing for off-mains wastewater

### Overview

The Marsh Ensign is widely regarded as one of the most efficient, reliable and economical sewage treatment plants on the market.

The standard Ensign has been adapted to improve reliability and the Ensign:Ultra now brings unique enhancements to further improve noise level, treatment efficiency and final effluent quality.

#### Class leading performance

Tested and approved to BSEN12566-3/A1:2009 all Ensign units provide treatment well within national consent requirements. Published test results of 11.5:19.2:8.4mg/ltr (BOD:suspended solids:ammonia), with influent concentrations on test higher than those chosen by most competitor plants, effectively equates to 97% pollutant removal.

#### Unrivalled choice

Ranging in size from 4 to 50 PE in Ultra, Standard and Shallow versions of each, and with a wide range of ancillaries, almost all site, consent and budget requirements can be met by units from the range.

#### Why choose the Marsh Ensign?

End users, merchants and installers alike recommend the Ensign range due to its ease of installation, reliability, and cost-effective operation and maintenance. All backed by technical support from local contacts.



### Operating principle

In addition to anaerobic digestion taking place in the primary settlement chamber [2] the Ensign:Ultra unit allows the clarified water to pass into a second 'aeration' chamber [3] where it is treated to remove the dissolved constituents. Here aerobic bacteria, supported by diffused air and mobile media, ensures full treatment is achieved before the treated effluent and 'sloughed off' bacteria flows to a final settlement chamber [10]. The final effluent is then discharged to the drainage field or watercourse via a Polylok filter.

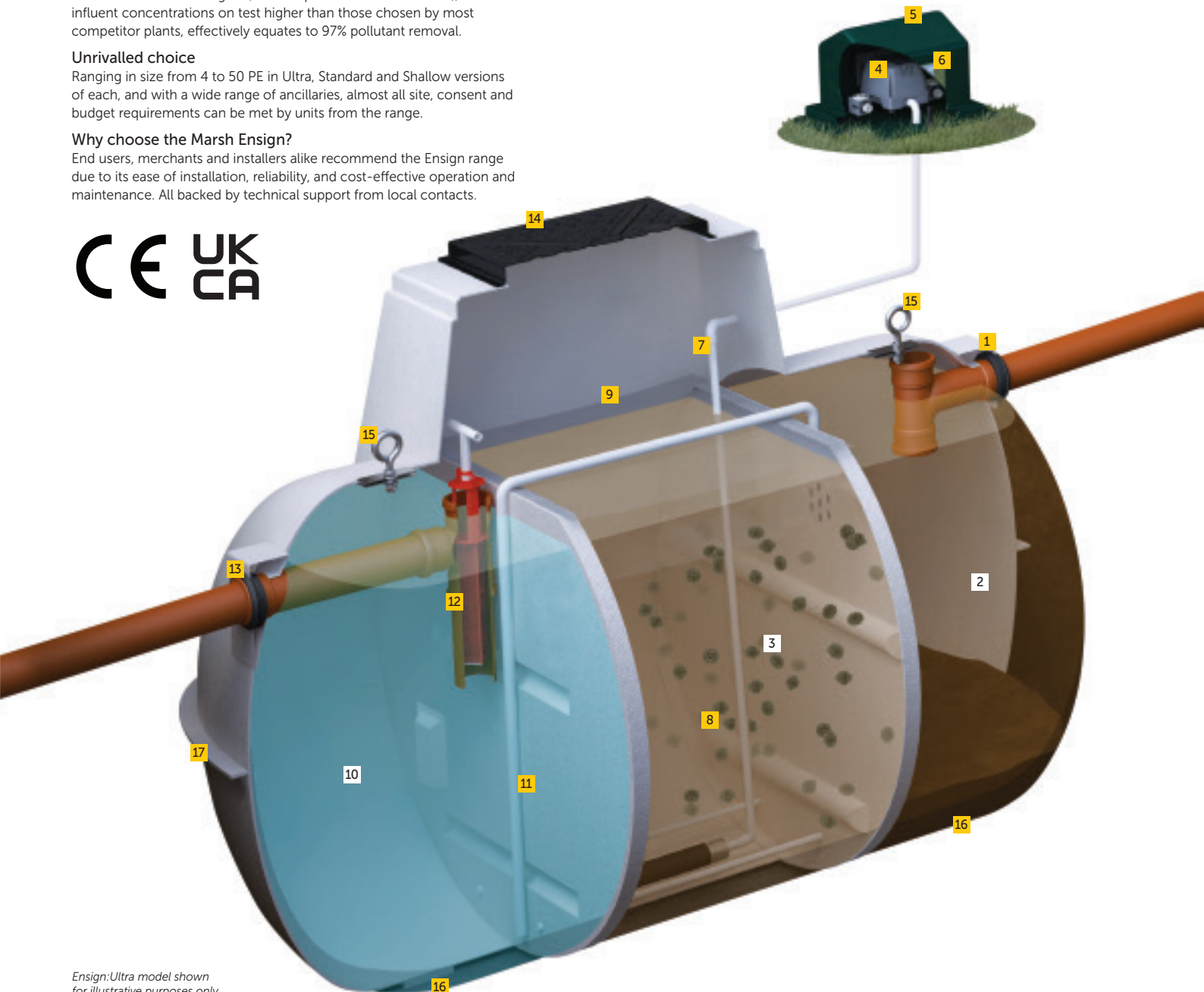

Ensign:Ultra model shown for illustrative purposes only

## Benefits

- 1 Inlet with 'Forsheda seal'**  
Forsheda seal provides flexibility in the joint for easier installation.  
*Optional risers to increase invert depth are available.*
- 2 Primary settlement chamber**
- 3 Aeration chamber**
- 4 Advanced compressor with alarm (Ensign:Ultra units only)**  
Near silent compressor ensures minimal running, maintenance and servicing costs. Integral alarm detects low pressure in air line. (Regular Low-energy compressor on Ensign:Standard models).
- 5 Compressor housing - internal or external options available**  
The compressor can be housed internally or externally with no difference in cost.  
*External recommended to increase compressor life, and supplied as standard on 4PE, shallow and pumped outlet versions.*
- 6 RCD/Electrical connection (Ensign:Ultra units only)**  
The RCD box provides easier installation and provides a higher degree of safety. (Regular plug/socket connection on Ensign:Standard models).
- 7 PVC pressure pipe/diffuser(s)**  
Provides a protective conduit for the air diffuser line. Can be easily removed for maintenance and cleaning.
- 8 Bio-media**  
High specification bio-media (310m<sup>3</sup> per m<sup>2</sup>) and membrane diffusers ensure even circulation to eliminate 'dead spots'. The bio-media is contained by a stainless steel securing mesh to ensure no migration during handling or potential flooding.
- 9 Stainless steel mesh (Ensign:Ultra units only)**  
Retains media in aeration chamber during transportation and handling, and in the event of flooding.
- 10 Final settlement chamber**
- 11 32mm sludge return**  
Larger diameter sludge return prevents the possibility of blockages and improves system circulation. Provides higher effluent quality whilst balancing flow over a 24 hour period or periods of intermittent use.
- 12 Unique Polylok tertiary filter (Ensign:Ultra units only)**  
The Polylok tertiary filter reduces suspended solids and BOD by a further 40% helping to extend drainage field life.
- 13 Outlet with 'Forsheda seal'**  
Forsheda seal provides flexibility in the joint for easier installation.  
*Optional pumped outlets are available.*
- 14 Impermeable lid (Ensign:Ultra units only)**  
Heavy duty lid/frame improves strength and durability whilst blending into the surrounding environment. (Regular lid on Ensign:Standard models).
- 15 Integral lifting eyes**  
For safe and secure on-site handling.
- 16 Stabilising feet**  
Stabilising feet prevents the tank from rolling and allows safe and steady transportation and installation.
- 17 Unique 'keying-in' lip**  
Assists anchoring into granular or concrete surrounds.

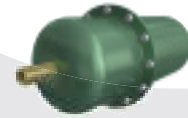

### Whisspurr

**Acoustic Vibration Reduction (AVR) unit**  
Reduces noise and vibration on all types of diaphragm compressors. See page 17.

## Guidance notes

Package Sewage Treatment Plant's (or PSTP's) are often a suitable option where groundwater in the surrounding environment is vulnerable, drainage field percolation values are restrictive, or direct discharge to a water course or surface water sewer is the preferred discharge method.

- *PSTP's should be sized using the latest version of British Water Flows & Loads which provides detailed information on sewage production figures and sizing calculations*
- *Regulatory authorities for the control of pollution in the UK normally require treatment plants conforming to BSEN12566:3 to be demonstrated as capable of producing a minimum effluent discharge quality of 20:30:20 (Biochemical Oxygen Demand;Suspended Solids: Ammoniacal Nitrogen in mg/ltr), although in certain areas more stringent site-specific qualities may be required*
- *No surface water should enter the system as this can reduce the system's capacity and cause solids to be flushed out which may prematurely block drainage field or cause pollution*
- *As with septic tanks sludge should be removed annually or in line with manufacturers instructions*

**Many domestic sewage treatment plants offered by "internet resellers" claim to hold EN12566-3 compliance. This does not necessarily mean compliance with the UK National Forward, May 2007.**

**These plants may have been tested in their country of origin but not tested to the same criteria as Marsh Industries, where we strictly adhere to the UK National Forward. Contact [contracts@marshindustries.co.uk](mailto:contracts@marshindustries.co.uk) for more information.**



“  
The Marsh Ensign is widely regarded as one of the most efficient, reliable and economical sewage treatment plants on the market

## Specifications

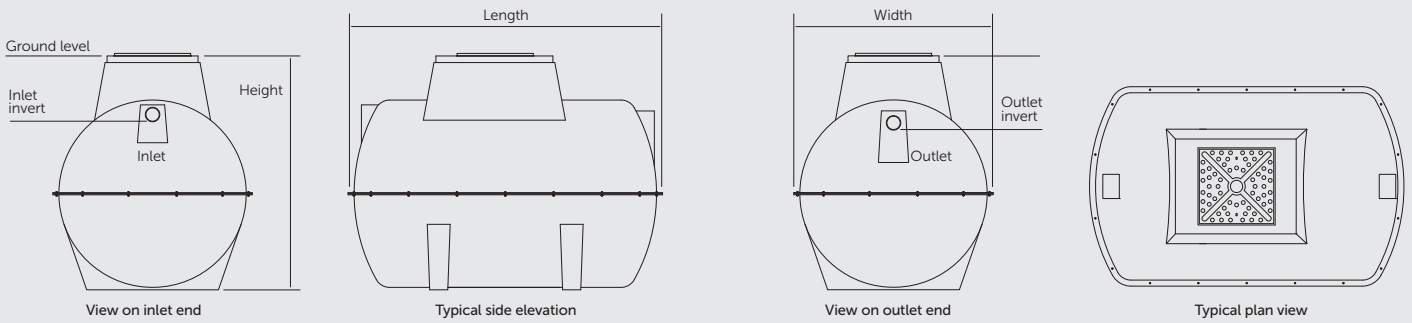

### Ensign:Ultra and Ensign:Standard

Model	Plant sizing examples (Approximate)		Length +/-50mm	Width +/-50mm	Height +/-50mm	Inlet		Outlet	
	Residential	Workplace (no canteen)				Invert	Ø	Invert	Ø
4	NA	6 people	1620	1352	1575	540	110	600	110
6	4-bed / 6 people	9 people	2602	1650	1935	550	110	625	110
8	5-bed / 8 people	12 people	2602	1650	1935	550	110	625	110
10	2 x 3-bed / 10 people	15 people	2602	1650	1935	550	110	625	110
12	2 x 4-bed / 12 people	18 people	2860	1912	2139	550	110	625	110
16	2 x 4-bed & 1 x 3-bed / 16 people	25 people	2860	1912	2284	720	110	800	110
20	3 x 4-bed / 18 people	32 people	3650	1912	2284	720	160	800	160
25	4 x 4-bed & 1 x 3-bed / 24 people	38 people	3650	1912	2284	770	160	850	160
30	5 x 4-bed or 6 x 3-bed / 30 people	48 people	4200	1912	2284	770	160	850	160
35	7 x 3-bed / 35 people	56 people	4200	1912	2284	770	160	850	160
40	8 x 3-bed / 40 people	72 people	5200	1912	2284	770	160	850	160
45	9 x 3-bed / 45 people	80 people	5200	1912	2284	770	160	850	160
50	9 x 3-bed / 45-50 people	80-90 people	5200	1912	2284	770	160	850	160

Notes:

- > Larger population sewage treatment plants may be supplied as multiple tank configurations.
- > For plant sizing, precise tank sizes and configurations, please contact Marsh Industries
- > All dimensions in mm

# Shallow units

Common sewage treatment plants on the market often exceed 2.3m high. Marsh Industries offer a range of shallow plants from 4-35PE that are only 1.6m in height, meaning installation is not only possible\*, but easier and safer too.

\*Shallow Ensign's are often favoured when hard rock site conditions mean deeper alternatives, involving costly and time-consuming excavation.

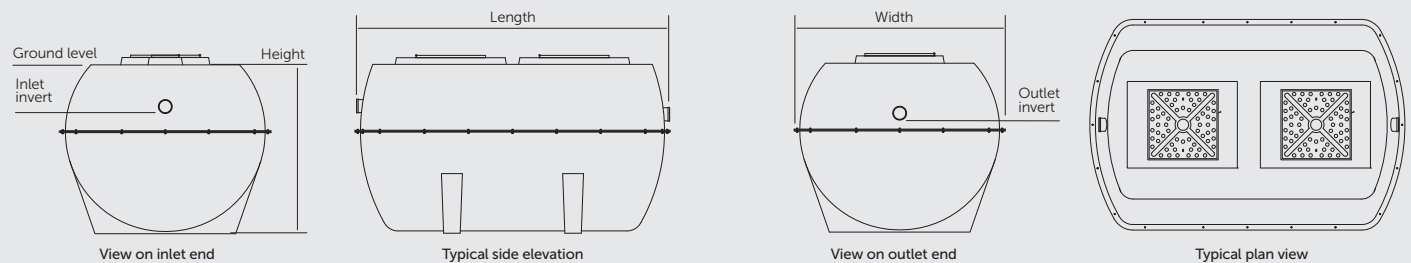
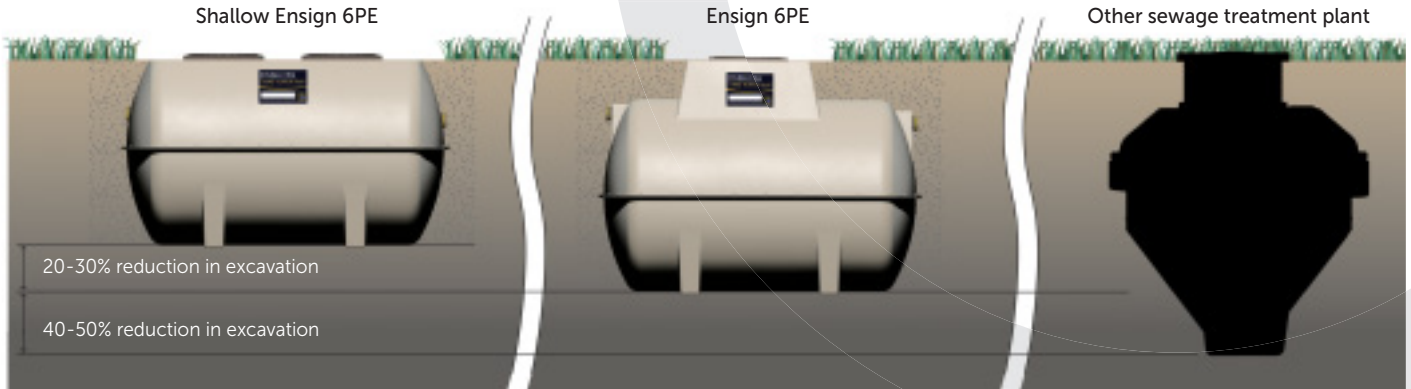

## Shallow Ensign:Ultra and Shallow Ensign:Standard

Model	Plant sizing examples (Approximate)		Length +/-50mm	Width +/-50mm	Height +/-50mm	Inlet		Outlet	
	Residential	Workplace (no canteen)				Invert	Ø	Invert	Ø
6	4-bed / 6 people	9 people	2860	1912	1600	500	110	575	110
8	5-bed / 8 people	12 people	2860	1912	1600	500	110	575	110
10	2 x 3-bed / 10 people	15 people	2860	1912	1600	500	110	575	110
12	2 x 4-bed / 12 people	18 people	2860	1912	1600	500	110	575	110
16	2 x 4-bed & 1 x 3-bed / 16 people	25 people	3650	1912	1600	500	110	575	110
20	3 x 4-bed / 18 people	32 people	4200	1912	1600	500	160	575	160
25	4 x 4-bed & 1 x 3-bed / 24 people	38 people	4200	1912	1600	500	160	575	160
30	5 x 4-bed or 6 x 3-bed / 30 people	48 people	5200	1912	1600	500	160	575	160
35	7 x 3-bed / 35 people	56 people	5200	1912	1600	500	160	575	160

### Notes:

- > Larger population sewage treatment plants may be supplied as multiple tank configurations.
- > For plant sizing, precise tank sizes and configurations, please contact Marsh Industries
- > All dimensions in mm

# Ultra:Polylok L™

## Sewage treatment plants

### Intensive biological processing for off-mains wastewater

## Overview

The Marsh Ultra:Polylok L (UPL) draws upon Marsh Industries' extensive experience in the industrial and commercial sewage treatment sectors bringing its outstanding performance and high-quality engineering to the domestic sector.

The UPL is available in 6PE and 12PE models, is approved to BS EN12566-3 and carries an impressive effluent quality of 20:30:20, within national consent standards.

Both models are compact and easy to install, meeting the needs of installers and specifiers alike.

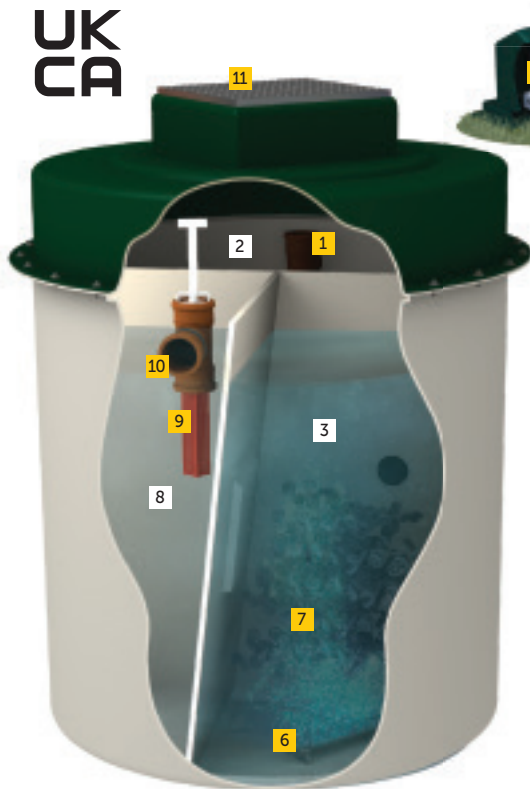

### Key

- 1 Inlet
- 2 Primary settlement chamber
- 3 Aeration chamber
- 4 Compressor with alarm
- 5 Compressor housing
- 6 Air diffuser
- 7 Bio-media
- 8 Final settlement chamber
- 9 Polylok tertiary filter
- 10 Outlet
- 11 Heavy duty lid



**Whisspurr**  
Acoustic Vibration  
Reduction (AVR) unit  
Reduces noise and vibration  
on all types of diaphragm  
compressors. See page 17.

## Operating principle

The UPL uses a similar operating principle as the Marsh:Ensign.

In addition to anaerobic digestion taking place in the primary settlement chamber [2] the UPL unit allows the clarified water to pass into a second 'aeration' chamber [3] where it is treated to remove the dissolved constituents. Here aerobic bacteria, supported by diffused air and mobile media, ensures full treatment is achieved before the treated effluent and 'sloughed off' bacteria flows to a final settlement chamber [8]. The final effluent is then discharged to the drainage field or watercourse via a Polylok filter.

## Specifications

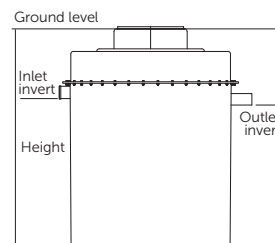
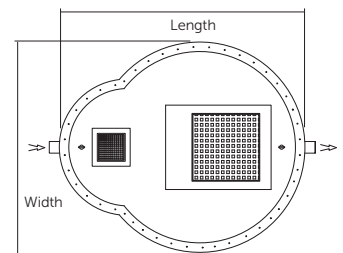
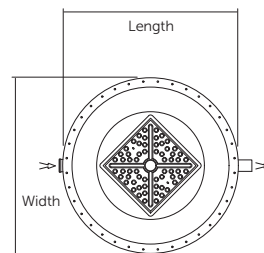

UPL 6

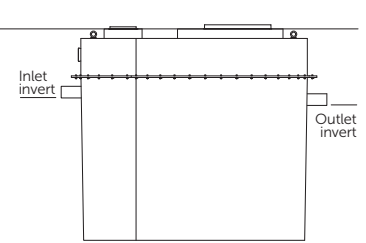

UPL 12

## Benefits

- Tested and approved to the most stringent European Standards: EN12566-3: 2005+A1:2009
- Small footprint and shallow dig for easy installation provides enhanced health and safety benefits
- Heavy duty shell as standard enables installation in all ground conditions. Unique 'keying-in' lip assists anchoring into granular or concrete surrounds
- Near silent, energy efficient compressor (located externally) with integral alarm (approximate annual running costs of £35 p/annum)
- High specification bio-media (310m<sup>3</sup> per m<sup>2</sup>) and membrane diffuser ensures even circulation and maximum treatment efficiency
- Unique Polylok tertiary filter reduces suspended solids and BOD by a further 40% helping to extend drainage field life
- Sludge return pipe improves system circulation
- Variable inverts for ease of installation at various depths – 250, 500 and 750mm risers available
- Pumped outlets available

Model (Pop)	Length +/-50mm	Width +/-50mm	Height +/-50mm	Inlet		Outlet	
				Invert	Ø	Invert	Ø
UPL 6	1700	1700	2050	650	110	725	110
UPL 12	2300	1992	2003	650	110	725	110

### Notes:

- > For precise tank sizes and configurations, please contact Marsh Industries
- > All dimensions in mm



# Portapura®

## Sewage treatment plants

Compact, portable, cost-effective solution for domestic sites

### Overview

The Marsh Portapura is the most compact and efficient sewage treatment plant we've ever made.

Designed for small domestic premises, temporary accommodation and workshops, the Portapura is portable, can be installed above or below ground and treats domestic wastewater to a level that is 25 times better than the recommended EN standard..

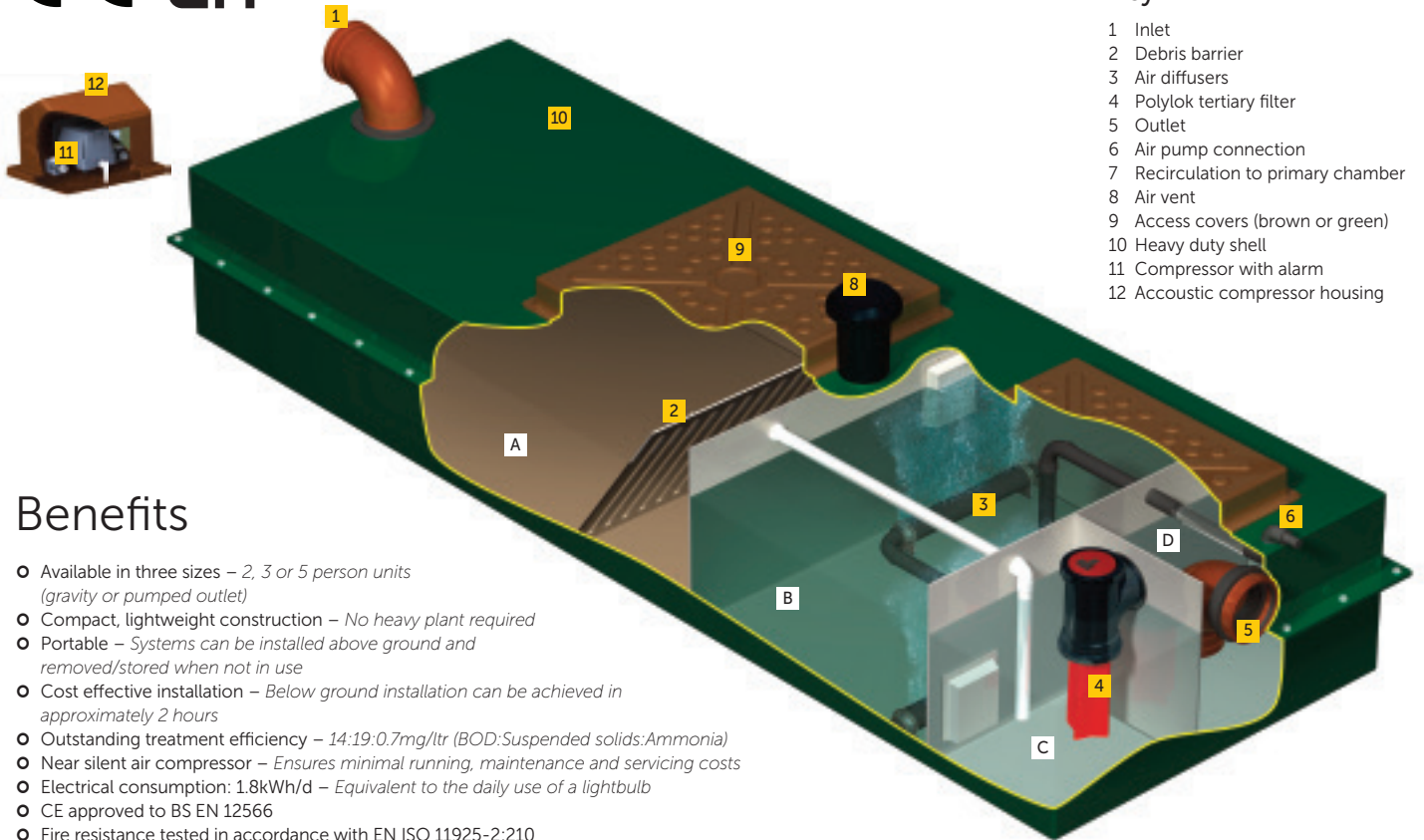

### Key

- 1 Inlet
- 2 Debris barrier
- 3 Air diffusers
- 4 Polylok tertiary filter
- 5 Outlet
- 6 Air pump connection
- 7 Recirculation to primary chamber
- 8 Air vent
- 9 Access covers (brown or green)
- 10 Heavy duty shell
- 11 Compressor with alarm
- 12 Acoustic compressor housing

### Benefits

- Available in three sizes – 2, 3 or 5 person units (gravity or pumped outlet)
- Compact, lightweight construction – No heavy plant required
- Portable – Systems can be installed above ground and removed/stored when not in use
- Cost effective installation – Below ground installation can be achieved in approximately 2 hours
- Outstanding treatment efficiency – 14:19:0.7mg/ltr (BOD:Suspended solids:Ammonia)
- Near silent air compressor – Ensures minimal running, maintenance and servicing costs
- Electrical consumption: 1.8kWh/d – Equivalent to the daily use of a lightbulb
- CE approved to BS EN 12566
- Fire resistance tested in accordance with EN ISO 11925-2:210
- Tested for structural integrity in accordance with EN ISO 179-1/1eA

### Specifications

Model	People served	Length +/-50mm	Width +/-50mm	Height +/-50mm	Inlet Invert (A)	Outlet Invert (B)	In/out Ø
M2	Up to 2	2750	980	415	445	270	Ø110
M3	Up to 3	2050	1500	600	450	245	Ø110
M5	Up to 5	2640	1500	800	650	345	Ø110

Notes:

- > For precise tank sizes and configurations, please contact Marsh Civils
- > Larger population plants can be supplied
- > All dimensions in mm

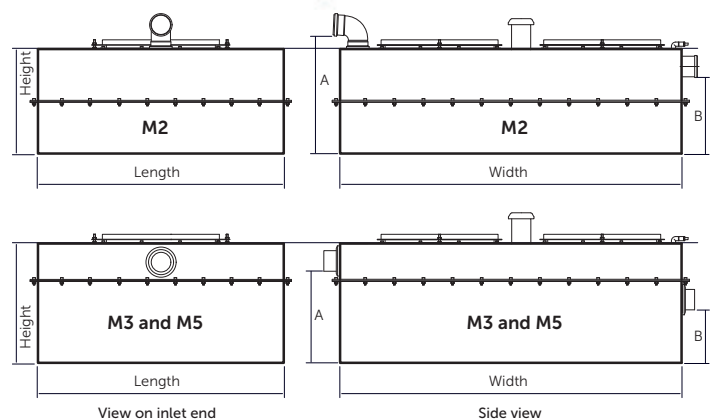

# GEM-APS EN12566-7 Certified Aerated Precipitation System

Eco-friendly, economical phosphate and ammonia reduction

Introducing the latest innovation in our extensive portfolio of wastewater treatment solutions: the Marsh Gem-APS (Aerated Precipitation System)

Remote alert monitoring available for dosing. This can alert either Marsh Industries or the occupier when additional chemicals are required (including SMS/Telemetry options).

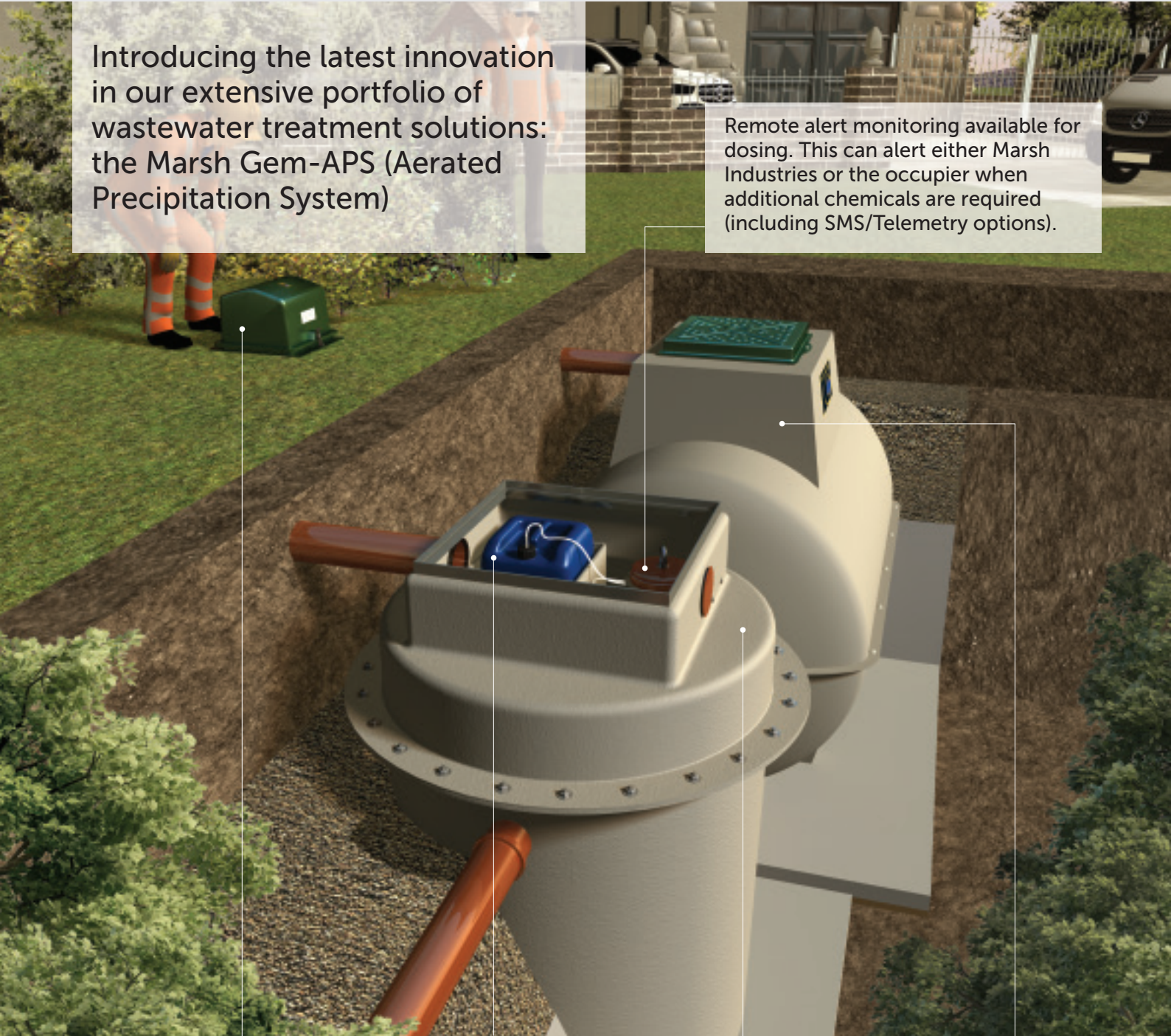

**Air blower and control panel housing**  
Chemical dosing process is pre-configured based upon the expected flows and loads of the sewage treatment plant

**Chemical dosing components**  
Controlled process involving chemical dosing and aeration

**Gem-APS**  
Economical, efficient, and cost-effective phosphate, ammonia and BOD reduction unit

**Package sewage treatment plant**  
The Gem-APS can be positioned at the outlet end of any existing sewage treatment plant (dependent on sizing)



The Gem-APS is a unique innovation for use on sites where phosphate discharge is a problem or where ammonia and BOD requirements are strict for planning consent.

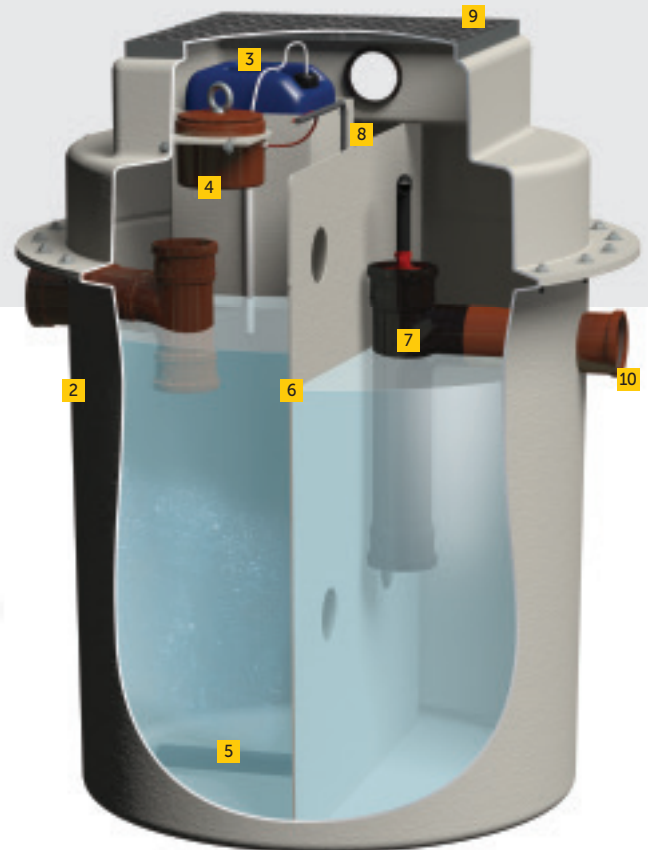

## Overview

The Gem-APS is designed to further reduce phosphates, ammonia and BOD from wastewater that has been previously treated in a domestic sewage treatment plant.

Positioned at the outlet end of any existing sewage treatment plant, the Gem-APS treats the discharged wastewater in a controlled process, involving small volumes of chemical dosing and aeration, in compliance with British Water and local environmental regulations, allowing the remaining effluent to be safely discharged to a river, ditch or drainage field.

Chemical dosing amounts are pre-configured based upon the expected flows and loads of the sewage treatment plant (Full scaleable detail available). The Gem-APS can also be regulated to reduce phosphate levels further.

For precise sizing and product specification, please contact the Marsh Civils team on 01933 829470 or email [contracts@marshindustries.co.uk](mailto:contracts@marshindustries.co.uk)

Marsh offers commissioning and servicing of the Gem-APS, it is strongly advised to use this service when setting up the unit.

## Benefits

- Tested in accordance with BS EN 12566-7 Annex A at PIA GmbH test facility in Aachen, Germany
- Small footprint and shallow dig for easy installation provides enhanced health and safety benefits
- Heavy duty shell as standard enables installation in all ground conditions. Unique 'keying-in' lip assists anchoring into granular or concrete surrounds
- Near silent, energy efficient compressor (located externally) with integral alarm
- Unique Polylok tertiary filter reduces suspended solids helping to extend drainage field life
- Lockable lid for safety and security
- Low level chemical alarm/indicator to ensure continuous phosphorus reduction. Remote alert monitoring also available.

## Features

- Inlet
- GRP tank appropriately sized for the sewage treatment plant
- Dosing chemical container
- Dosing chemical pump in watertight housing
- Aeration diffuser(s)
- Separating baffle with grate to stop media migration
- Polylok filter for solids and flocculent capture
- Pipework and sludge return
- Lockable lid for safety and security
- Outlet

## Guidance notes

- The Marsh Gem-APS phosphate and ammonia reduction unit should discharge effluent into a drainage field.
- The Gem APS can dose Iron or aluminium
- Environment Agency guidance states the following in relation to aluminium discharge limits to surface water:

*"Aluminium is acutely toxic to fish. For discharges to receiving waters with a lower 95-percentile pH value greater than or equal to 6, the EQS is a maximum allowable concentration (MAC) of 1mg/l (total).*

*However, we will also apply an emission standard of 10mg/l (dissolved) as a maximum concentration in the effluent if dilution is greater than 1:10. These standards reduce the possibility of active aluminium occurring downstream of the discharge. They also minimise deposition of particulate aluminium on the bed of a watercourse. At dilutions of less than 10:1 the total aluminium standard also limits dissolved aluminium in the discharge.*

### Aluminium limits for receiving waters with low pH

*Aluminium in receiving waters with a low pH may remain in solution or re-dissolve. These waters are likely to already contain some dissolved aluminium, so the capacity to accept more will be limited.*

*We therefore apply different limits for aluminium in discharges to receiving waters that have a lower 95-percentile pH value of less than 6.*

*For soft waters, where the calcium carbonate concentration is less than 20mg/l annual average, the EQS is a 95-percentile limit of 75µg/l (dissolved).*

*MAC of 100µg/l (dissolved) we will apply an emission standard of 500µg/l (total) as a maximum concentration in the effluent. For hard waters, where the calcium carbonate concentration is greater than or equal to 20mg/l annual average, the EQS is a 95-percentile limit of 500µg/l (dissolved).*

*MAC of 1mg/l (dissolved) we will apply an emission standard of 1mg/l (total) as a maximum concentration in the effluent. For receiving waters that already contain aluminium, we consider discharge limits on a detailed, site-specific basis".*

**Phosphate: 0.9mg/L**  
**Ammonia: 0.4mg/L**  
**BOD: 2mg/L**



# Uni:Gem★

## Septic conversion unit

Unique septic tank to sewage treatment plant conversion unit

### Overview

Marsh Industries' latest innovation, the Uni:Gem★, is a unique septic tank conversion unit which exceeds EN12566-3 / EN12566-6 standards and conforms with 2020 General Binding Rules (GBRs for septic tanks or small sewage treatment plants for domestic use).

Positioned behind any existing septic tank the Uni:Gem★ treats the septic tank discharge to an effluent quality of BOD 12.25:TSS 16:Ammonia 14.845 mg/l (The UK Forward is less than BOD 20:TSS 30: Ammonia 20), meaning final effluent can be discharged safely to a river, ditch or watercourse.

The Uni:Gem★ provides notable benefits for existing septic tank owners, particularly those who need to upgrade or replace their septic tanks.



### Operating principle

Effluent from the existing septic tank or sewage treatment plant is transferred to the Uni:Gem★ unit and enters the aeration chamber where it is treated to remove dissolved constituents. Here aerobic bacteria, supported by diffused air and mobile media, ensures full treatment is achieved before the treated effluent (and 'sloughed off' bacteria) flows to a final settlement chamber prior to discharge.

#### Key

- 1 Existing septic tank
- 2 Uni:Gem★ tank
- 3 Inlet
- 4 Aeration chamber
- 5 Air diffuser
- 6 Transfer to final settlement
- 7 Final settlement
- 8 Outlet
- 9 Air diffuser feed
- 10 Bio media
- 11 Manway access



**Whisspurr**  
Acoustic Vibration Reduction (AVR) unit  
Reduces noise and vibration on all types of diaphragm compressors. See page 17.

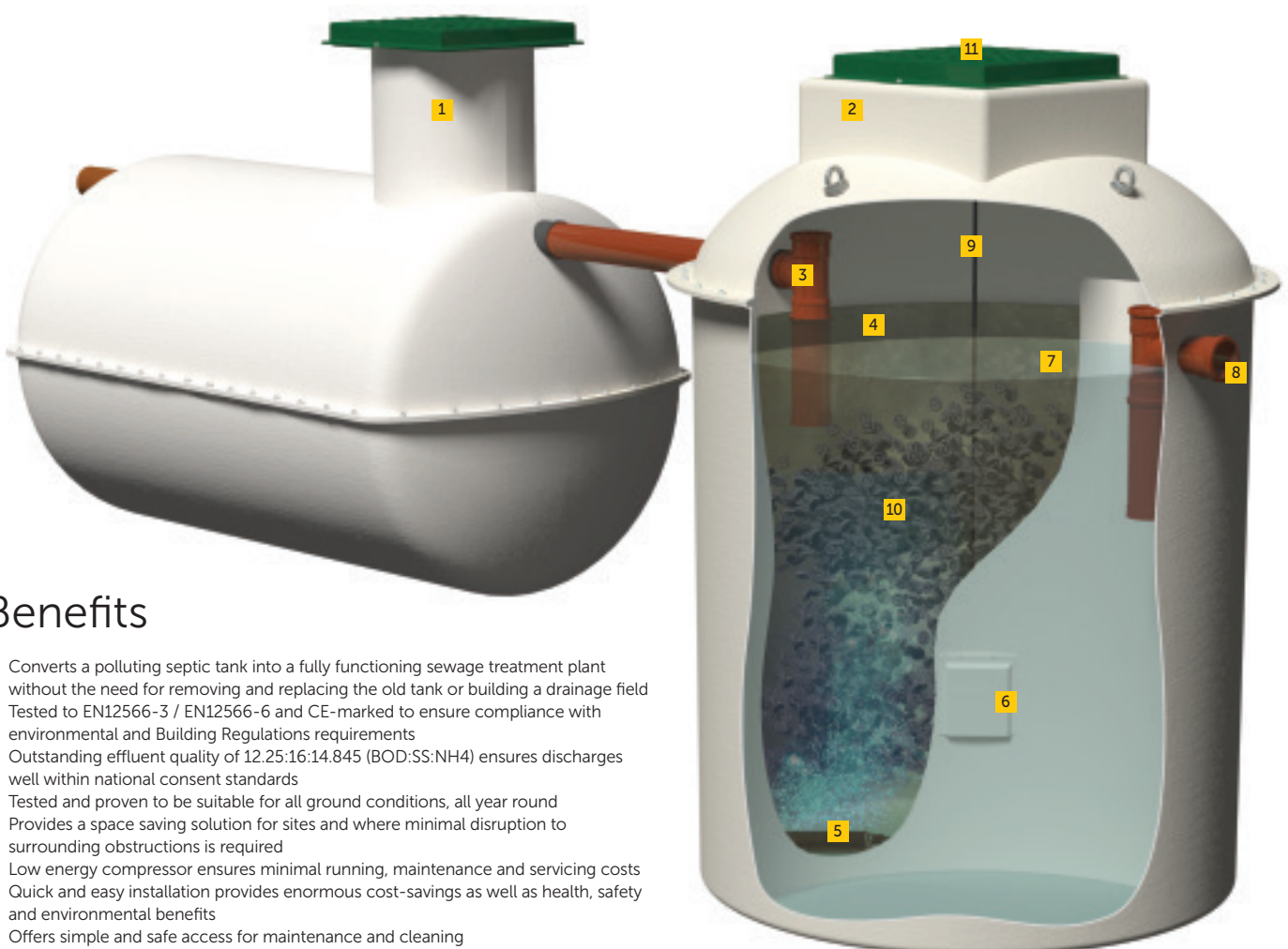

### Benefits

- Converts a polluting septic tank into a fully functioning sewage treatment plant without the need for removing and replacing the old tank or building a drainage field
- Tested to EN12566-3 / EN12566-6 and CE-marked to ensure compliance with environmental and Building Regulations requirements
- Outstanding effluent quality of 12.25:16:14.845 (BOD:SS:NH4) ensures discharges well within national consent standards
- Tested and proven to be suitable for all ground conditions, all year round
- Provides a space saving solution for sites and where minimal disruption to surrounding obstructions is required
- Low energy compressor ensures minimal running, maintenance and servicing costs
- Quick and easy installation provides enormous cost-savings as well as health, safety and environmental benefits
- Offers simple and safe access for maintenance and cleaning
- Horizontal and vertical models available
- Integral lifting eyes for improved on-site handling
- Final effluent is clear and odourless



## Specifications

Model	Width Ø +/-50mm	Height +/-50mm	Inlet		Outlet	
			Invert	Ø	Invert	Ø
<b>A</b> UG-SCS Uni:Gem★ up to 6PE For shallow cylindrical septic tanks	1512 1652 over flanges	2300	800	110	900	110
<b>B</b> UG-SPH Uni:Gem★ up to 6PE For spherical 'onion-shaped' septic tanks	1512 1652 over flanges	2540	1040	110	1140	110
<b>C</b> UG-STP6 2800L septic tank Uni:Gem★ up to 6PE EN12566-6 complete package sewage treatment plant	1870	2330	550	110	590	110
	1512 1652 over flanges	2090	590	110	690	110

- > Uni:Gem★ supplied with external compressor and compressor housing
- > Check your septic tank outlet invert (ground level to the bottom of the pipe)
- > Other sizes of Uni:Gem★ are available. Contact Marsh Industries for more information
- > For precise tank sizes and configurations, please contact Marsh Industries
- > All dimensions in mm

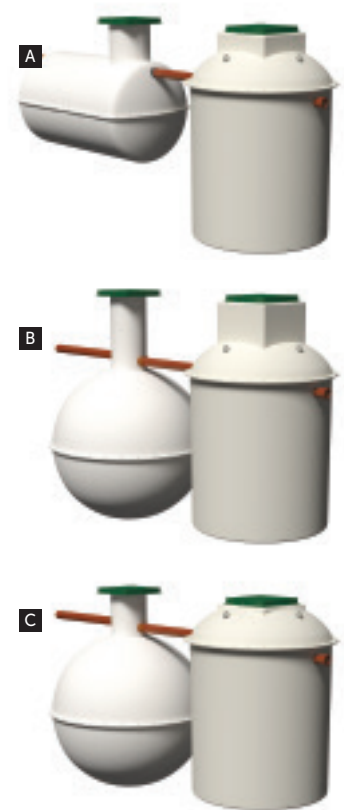

## 2020 General Binding Rules

For decades, millions of septic tanks have been installed throughout the UK in rural and urban areas. Septic tanks are known to be ineffective at processing sewage to modern environmental standards, causing long-term damage to the country's natural water infrastructure and wildlife.

It was therefore inevitable that new rules and a code of conduct would be introduced to prevent the effects of wastewater pollution once and for all; The Environmental Permitting (England and Wales) (Amendment) (England) Regulations 2014 came into force on 1 January 2015 creating the General Binding Rules (GBRs) for septic tanks or small sewage treatment plants for domestic use. These rules are designed to reduce the level of pollution from sewage in the nation's watercourses.

The rules state that any existing septic tank discharging to surface water, ie, to a water ditch, stream or river, etc, must either be upgraded or replaced with a new package sewage treatment plant (by 1st January 2020).

Marsh Industries, the leading UK manufacturer of package sewage treatment plants, produces over 3000 units per year. However the company's range of Uni:Gem★ septic conversion units is the only product available on the market which can treat wastewater from an existing septic tank without the need for a complete replacement product or drainage field upgrade.

To comply with the GBRs and current EN standards, the entire Uni:Gem range was redeveloped from the ground up and tested, not only to meet, but to exceed UK and International standards. The Uni:Gem★ was born – creating an 'industry first' 2020 compliant septic conversion unit with outstanding processing performance.

The Uni:Gem★ range was tested in accordance with BSEN12566-3/A1:2009 and EN12566-6 standards at the PIA GmbH test facility in Aachen, Germany, over the course of 38 weeks with a daily loading of:

**Flow: 900 litres/day      BOD: 360g      NH<sub>4</sub>: 48g**

Testing occurred between November 2018 and August 2019 to ensure all seasons were covered whilst minimum/maximum temperatures were tested to assure Ammonia and BOD process reduction for the UK climate. Holiday periods were also simulated during the test procedure.

Final test results yielded an output of 12.5:16:4mg/ltr (BOD:Suspended solids:Ammonia) that is well within national discharge consent requirements.

The Uni:Gem★ is an extremely cost effective solution for converting any polluting septic tank into a fully compliant sewage treatment plant ensuring homeowners, estate managers, water companies/amenities have an effective way to keep the environment clean whilst providing a quick and efficient installation process.

# Euro:Septic<sup>®</sup> / Septic tanks

Economical storage and disposal of domestic wastewater

## Overview

The Euro:Septic offers significant technical improvements and cost-savings over current market options.

The range, available in capacities from 2800-4500 litres, is CE marked to comply with Construction Product Regulations and complements the company's existing range of horizontal septic tanks.

The Euro:Septic is tested and certified to EN12566-1 Annex B and benefits from an outstanding hydraulic efficiency of 99.63%. Horizontal septic tanks are also tested and certified to EN12566-1.

Marsh standard horizontal septic tanks are available in capacities from 2800-20,000+ litres, and are tested for material impact integrity and the impingement of flame.

## Key

- 1 Inlet
- 2 Settlement chamber
- 3 Polylok filter (Euro:Septic units only)
- 4 Outlet
- 5 Access cover



Septic tank model shown for illustrative purposes only

## Operating principle

Normally the simplest and most economical means of treating wastewater from small developments, a septic tank holds sewage and allows solids to settle into sludge at the bottom of the tank. Here it is naturally broken down by a process known as anaerobic digestion, which provides settlement and some biological treatment. The effluent is not fully treated and must receive additional treatment before discharge to the water environment – the most common method being to spread the effluent to land via an underground drainage field (Designed in accordance with BS6297).

## Benefits

- Tested to BSEN12566:1 and CE-marked to ensure compliance with latest environmental and Building Regulations requirements
- Traditional 'onion-style' tanks for standard installations
- Low profile versions for high water table or hard rock site conditions
- Unique Polylok filter improves effluent quality and prolongs drainage field life (Euro:Septic units only)
- Heavy duty shell as standard to enable installation in all ground conditions
- Integral lifting eyes for improved on-site handling
- 'Keying-in' assists anchoring into granular or concrete surround
- Pedestrian cover included as standard

# Specifications

## Euro:Septic

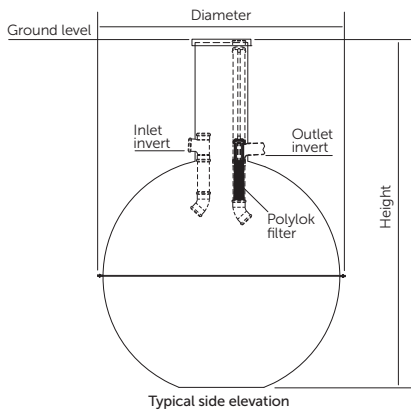

Size	Dia +/-50mm	Height +/-50mm	Inlet		Outlet	
			Invert	Ø	Invert	Ø
2800L	1870	2780	1000	110	1040	110
3800L	2075	3000	1000	110	1040	110
4500L	2196	3100	1000	110	1040	110

> For precise tank sizes and configurations, please contact Marsh Industries  
 > All dimensions in mm

## Horizontal septic tanks

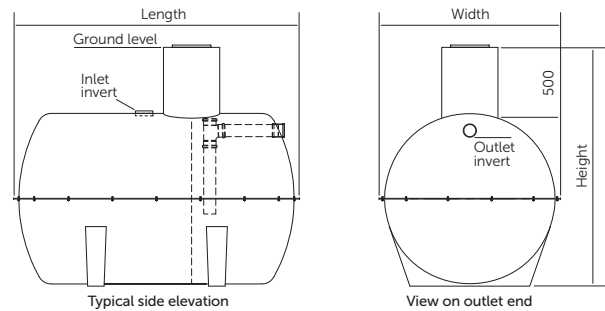

Size	Length +/-50mm	Width +/-50mm	Height +/-50mm	Inlet		Outlet	
				Invert	Ø	Invert	Ø
2800L	3000	1250	1750	500	110	800	110
3800L	4000	1250	1750	500	110	800	110
4500L	2650	1600	2100	500	110	800	110
6000L	2950	1900	2400	500	110	800	110
8000L	3640	1900	2400	500	160	800	160
10000L	4200	1900	2400	500	160	800	160
12000L	5200	1900	2400	500	160	800	160
14000L	5840	1900	2400	500	160	800	160
16000L	6700	1900	2400	500	160	800	160
18000L	7500	1900	2400	500	160	800	160
20000L	8100	1900	2400	500	160	800	160

## Discharge options

A septic tank can only be discharged in the following ways:

- To an existing foul sewer**  
This may not be possible in remote locations, although pump chambers can be used to direct wastewater to the mains sewer.
- To a drainage field, designed in accordance with BS6297**  
This allows the septic tank to discharge wastewater into the ground. In many cases, the installation of a drainage field is not possible due to site constraints such as space and/or the soil not having sufficient drainage potential (ie, rock, clay, high water table). If this is the case, then a Marsh Ensign package sewage treatment plant may be required.

# Cesspools

## Basic storage and disposal of off-mains wastewater

### Overview

A cesspool is a covered, watertight tank used for storing sewage. It has no outlet and relies on road transport for the removal of raw sewage. No treatment is involved.

Available in capacities up to 20,000 litres, the tanks are manufactured using GRP (virgin unfilled resin - no 'fillers' such as chalk) providing consistent wall thickness ensuring superior structural strength and durability. This also enables the tank to be significantly lighter for on-site handling/positioning and better suited to withstand greater hydrostatic pressures when in use.

The tanks are supplied with a chemically resistant gel-coat that protects the fibres in the laminates and provides excellent water and chemical resistance. This inherent integrity allows Marsh to offer an unrivalled 50 year design life, backed by a 25 year structural guarantee.

### Benefits

- Available in capacities from 2800-20,000 litres
- Designed to meet latest UK and European standards
- Heavy duty shells enable installation in all ground conditions
- Variable invert depths and orientations to suit individual site conditions
- Optional high-level alarm available
- Guaranteed for 25 years with a design life of 50 years

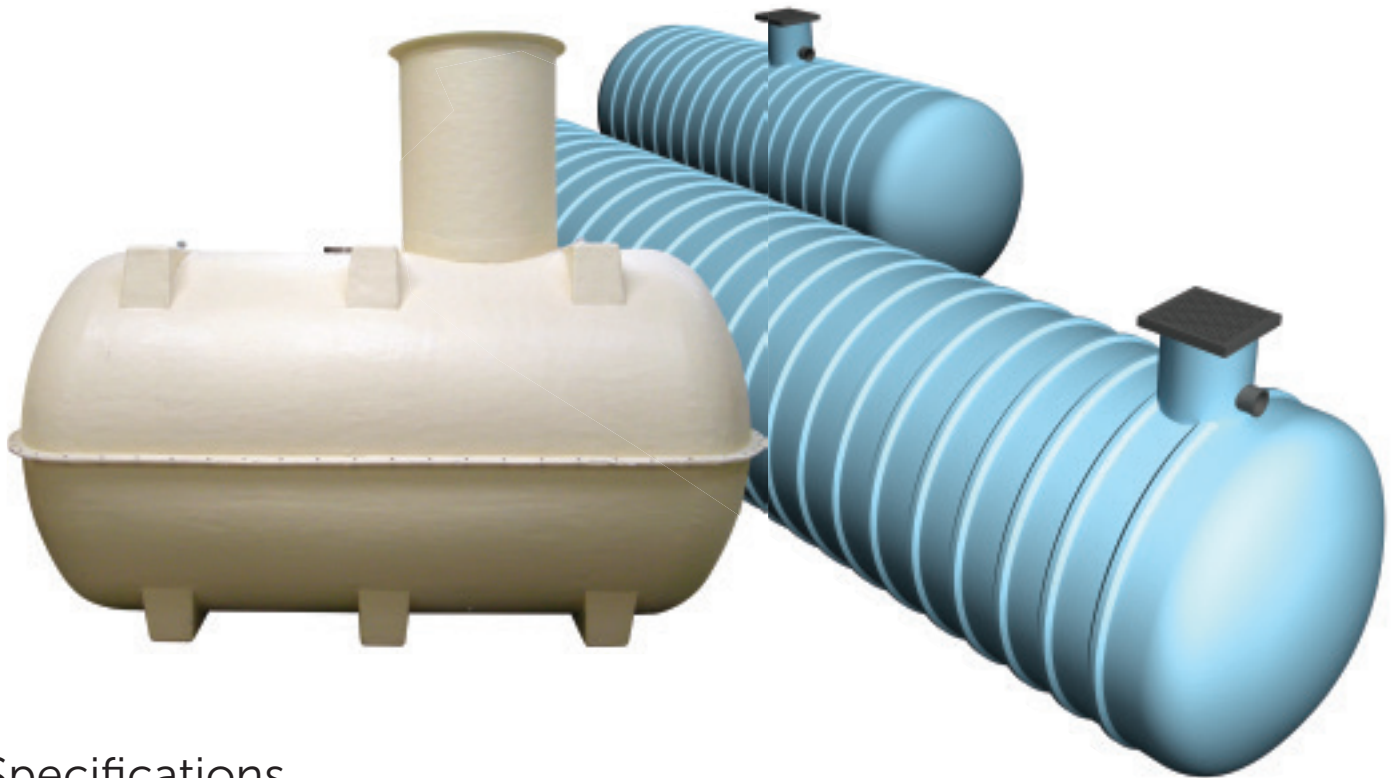

### Specifications

Model	Length	Width	Height	Inlet	
				Invert	Ø
AT2800	3000	1250	1750	500	110
AT3800	4000	1250	1750	500	110
AT4500	2650	1600	2100	500	110
AT6000	2950	1900	2400	500	160
AT8000	3640	1900	2400	500	160
AT10000	4200	1900	2400	500	160
AT12000	5200	1900	2400	500	160
AT14000	5840	1900	2400	500	160
AT16000	6700	1900	2400	500	160
AT18000	7500	1900	2400	500	160
AT20000	8100	1900	2400	500	160

> All dimensions in mm

> For precise tank sizes and configurations, please contact Marsh Industries

### Guidance notes

- For domestic applications cesspools should have a capacity below the level of the invert of at least 18,000ltrs for two users, and should be increased by 6800ltrs for each additional user. Cesspools for commercial premises have no such restrictions
- Installation of a high level alarm is recommended to indicate when it is nearly full
- Whoever empties your cesspool (or septic/PSTP) should be a registered Waste Carrier and hold a current discharge licence from the local water authority
- Use of cesspool is not permitted in Scotland



# Whisspurr®

## Acoustic Vibration Reduction (AVR) Unit

### Overview

Introducing Whisspurr, the innovative AVR unit designed to reduce noise and vibration from diaphragm compressors used in the water and wastewater treatment sectors.

Fitted inline between the compressor and air diffuser, the Whisspurr significantly reduces noise and vibration generated from the pulsation of the diaphragm compressor whilst enabling a consistent, unrestricted flow to the air diffuser.

The Whisspurr is suitable for all types of compressor; Bibus Secoh, Charles Austen, Nitto, etc.

For accurate unit sizing, contact Marsh Industries' technical team on 01933 654582.

- Significantly reduces compressor volume and vibration, addressing concerns of noise pollution in rural areas
- No reduction in air pressure from the compressor
- No increase in back pressure to the compressor
- Requires no electrics
- Available in four standard sizes
- Easy retrofit to existing compressors
- Hose tail is 20mm standard
- Dark green unit as standard
- Unique UK design, patent pending
- Optional extras include Marsh acoustic compressor housings (Two sizes available depending on compressor size)

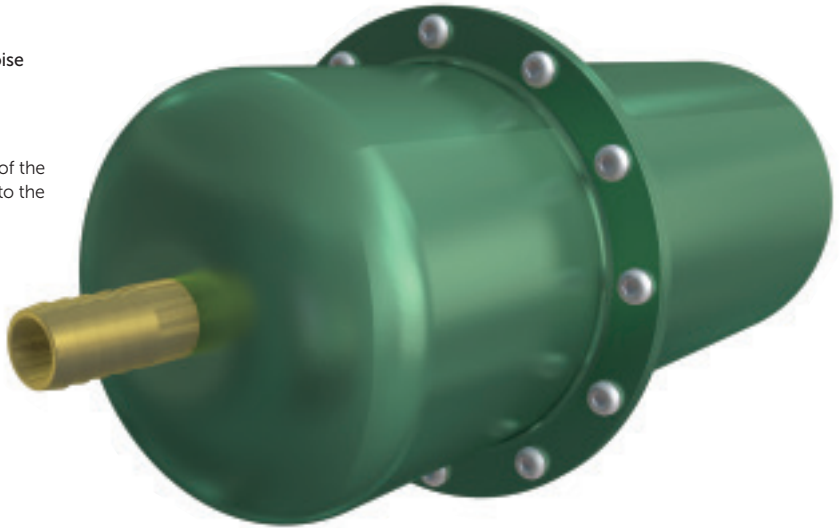

Hear the difference for yourself at [marshindustries.co.uk](http://marshindustries.co.uk)

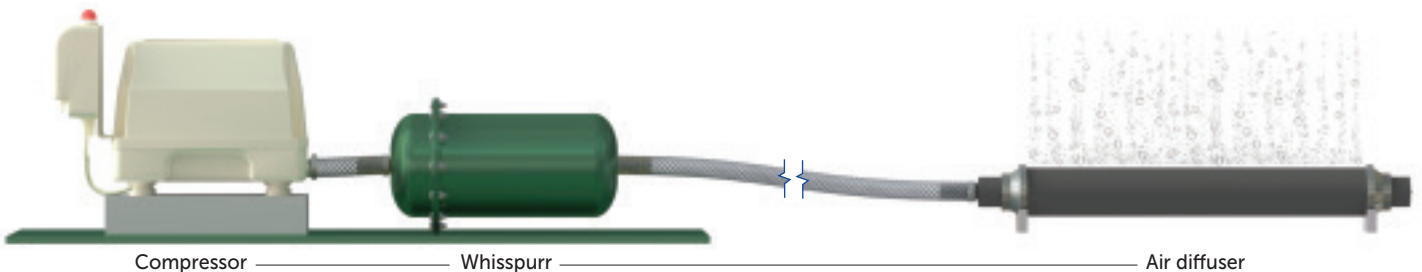
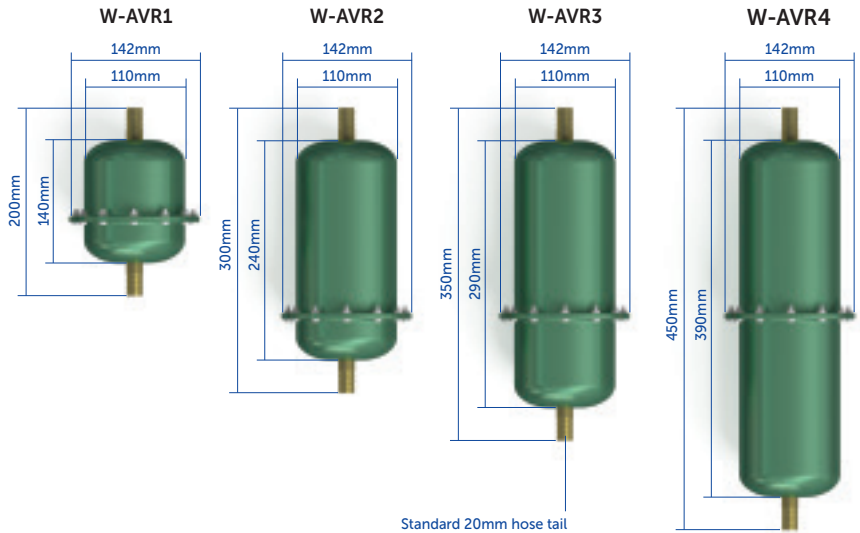

# Pump chambers

## For pumping sewage and water to mains

### Overview

When discharge to mains is required, but to do so by gravity is impractical, a pump chamber system will be needed. Although available as floor-mounted units for indoor applications such as basements, the vast majority are installed outdoors at levels to suit on-site conditions and topography.

The Marsh range incorporates systems for pumping surface water or domestic sewage to mains, septic/PSTP effluent to drainage fields/watercourses, and bespoke systems for larger domestic and industrial applications.



### Operating principle

Each pump chamber contains a number of float switches linked to a control panel that automatically controls flow and levels.

In a **single pump chamber** there are three float switches:

Float A: Actuates the pump cycle until level drops to low level.

Float B: Low level float stops the pump.

Float C: High level alarm – positioned above the pump actuator float (min 100mm).

For **twin pump chamber** operation there is an additional float switch (Float D) – usually positioned 150mm above first actuator (A) – which actuates the second pump in periods of higher flow.

After each cycle the pumps alternate to extend pump life and are designed to run for a minimum of 60 seconds with no more than 15 starts per hour.

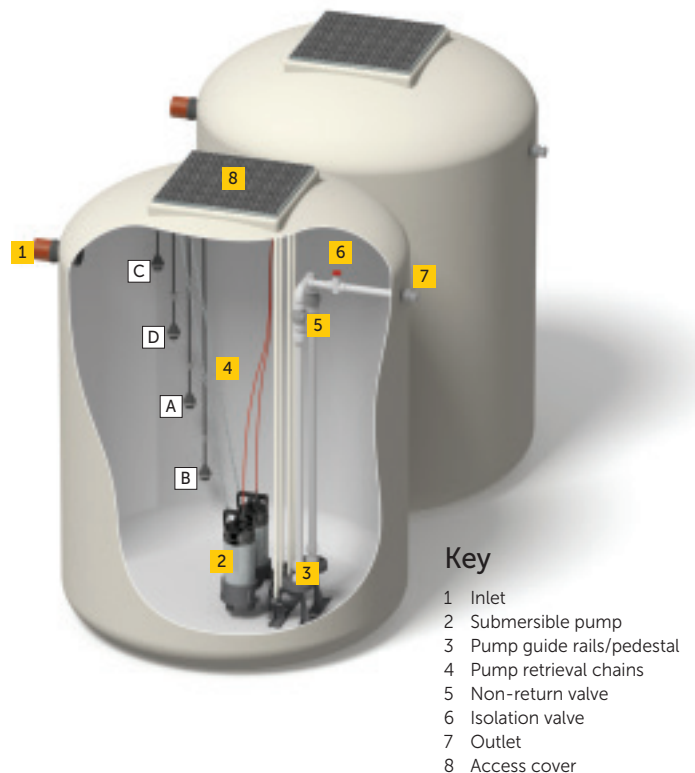

### Pump chamber benefits

- Designed to BSEN12050 for structural strength and water-tightness and to BSEN752 to comply with hydrostatic and electrical requirements
- Smooth internal walls and integral pump well improves pump efficiency and eliminates 'dead spots' which can lead to odours and septicity
- Pre-assembled pipework for fully automatic operation (pump/control equipment separate)
- Heavy duty (industrial) 'peardrop' floats and Lowara (Xylem) pumps throughout ensure robust, reliable design and maximum efficiency of pump with minimal clogging or wear
- Unique 'keying-in' lip to assist anchoring into concrete surround
- Variable invert depths and orientations to suit individual site conditions

### Guidance notes

- *Where foul water drainage from a domestic property is to be pumped to the mains the effluent receiving chamber should be sized to contain 24-hour inflow to allow for disruption in service, the minimum daily discharge being taken as 150 litres per person per day*
- *For other building types the capacity of the receiving chamber should be based on the calculated daily demand of the water intake for the building, or when only a proportion of the foul sewage is to be pumped then the capacity should be based pro-rata*
- *If the sewer is to be 'adopted' by a local water authority, please contact Marsh Industries as Sewers for Adoption (SFA) specification and additional local authority related criteria may apply*

# Specifications

## Vertical pump stations

For housing projects and small commercial developments

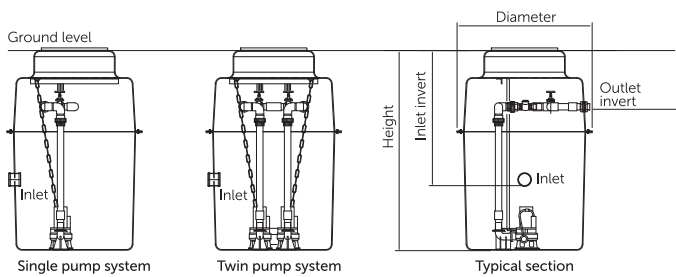

## Horizontal pump stations

For larger housing projects, and commercial/industrial developments

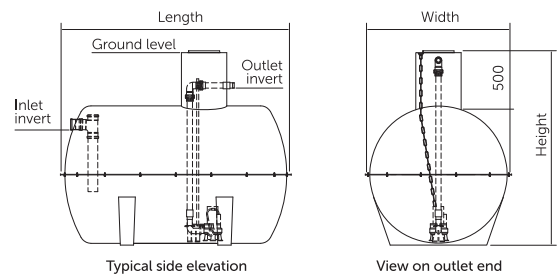

Model	Dia +/-50mm	Height +/-50mm	Inlet		Outlet		Storage below invert	Total Storage Litres
			Invert	Ø	Invert	Ø		
Mini	600	1100	500	110	300	63	120	234
Midi	600	1500	500	110	300	63	280	421
Maxi	600	2000	500	110	300	63	421	561
CPS1	1170	1100	500	110	300	63	470	867
CPS2	1170	1500	700	110	300	63	780	1183
CPS3	1170	2200	900	110	300	63	1025	1735
CPS4	1170	2600	900	110	300	63	1340	2050
CPS5	1958	2100	900	110	300	63	2440	3700
CPS6	1958	3400	900	110	300	63	4000	6000

Model	Length +/-50mm	Width +/-50mm	Height +/-50mm	Inlet		Outlet		Total Storage Litres
				Invert	Ø	Invert	Ø	
AT2800	3000	1250	1750	800	110	300	63	2800
AT3800	4000	1250	1750	800	110	300	63	3800
AT4500	2650	1600	2100	800	110	300	63	4500
AT6000	2950	1900	2400	800	160	300	63	6000
AT8000	3640	1900	2400	800	160	300	63	8000
AT10000	4200	1900	2400	800	160	300	63	10000
AT12000	5200	1900	2400	800	160	300	63	12000
AT14000	5840	1900	2400	800	160	300	63	14000
AT16000	6700	1900	2400	800	160	300	63	16000
AT18000	7500	1900	2400	800	160	300	63	18000
AT20000	8100	1900	2400	800	160	300	63	20000

**Notes:**

- > All pump chambers are available for dirty water (DW) or sewage (SW), in single pump (SP) and twin pump (TP) configurations. Pump chambers are usually bespoke.
- The dimensions given on this page are for guidance only
- > For precise tank sizes and configurations, please contact Marsh Industries
- > All dimensions in mm

## Pump chamber maintenance packages

Pump chamber maintenance packages provide peace of mind that your pump and associated equipment will continue to work reliably and effectively, whilst at the same time considerably extending their working-life expectancy.

Pump chambers covered by Marsh maintenance packages suffer far fewer intermediate breakdowns, making scheduled maintenance an extremely cost-effective safeguard against potential failure.

For details on Marsh pump chamber maintenance packages contact 01933 654582 or email [sales@marshindustries.co.uk](mailto:sales@marshindustries.co.uk).



# Accessories and ancillaries

## Marsh:UV disinfection unit

For over a century scientists have known about the ability of ultraviolet light (UV) to disinfect and, for many years, UV-C lamps have been used for disinfection in medical settings, food production and a number of other places.

Effluent disinfection using UV light is the decontamination of outflowing water from sewage treatment plants, sewer pipes or industrial outfall into natural bodies of water.

Without UV disinfection, effluent can retain a mass of hazardous pathogens that could infect the natural water, causing potentially serious environmental health issues.

UV light deactivates pathogens so that they cannot survive in clean water, meaning they cannot replicate and infect future waterways.

UV light is one of the safest disinfectants available due to the lack of chemicals used and produced by the device.

The most common method of effluent disinfection used in off-mains sewage treatment plants is to install and connect a separate UV disinfection unit to the outlet of the sewage treatment plant.

The UV disinfection unit contains the necessary UV light system to match the volume of outflow from the sewage treatment plant.

## The solution

Marsh Industries has developed an innovative UV disinfection system which removes 99% faecal coliform bacteria levels from sewage treatment plant effluent.

The Marsh:UV Disinfection Unit can be supplied as an integral part within the Marsh Ultra:Polylok range of sewage treatment plants (50-500+PE) or as a stand-alone unit which can be installed at the outlet end of any existing sewage treatment plant.

The UV light(s) are mounted in a sub-assembly which can be easily removed for periodic servicing and bulb replacement. In stand-alone units, the light assembly is mounted in a primary chamber by an anodized aluminium frame. The frame seals against the inner surface of the primary chamber to prevent flow bypass.

When the disinfection unit is filled with waste water, the ultraviolet light source operates continuously with a lamp surface temperature range of 105-120°F providing optimum UV light output and long lamp lifetime (Power supply is via 230v Single Phase with consumption of a single UV lamp being 45 watts).

In addition to the UV disinfection assembly, microfibre tertiary filters are attached at the inlet pipe to reduce any remaining suspended solids, residual BOD and ammonia levels.

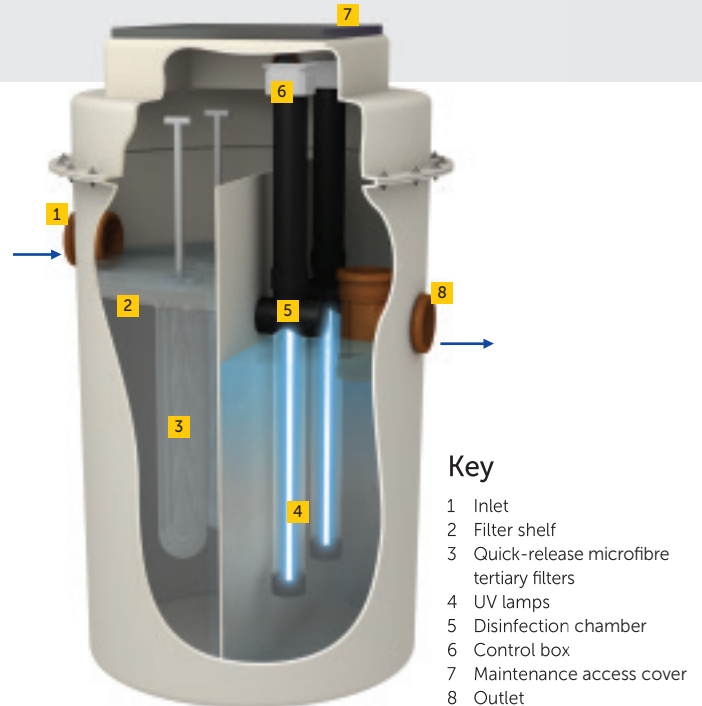

### Key

- 1 Inlet
- 2 Filter shelf
- 3 Quick-release microfibre tertiary filters
- 4 UV lamps
- 5 Disinfection chamber
- 6 Control box
- 7 Maintenance access cover
- 8 Outlet

## UV treatment performance

A single UV maximum flow through the unit is rated at 16m<sup>3</sup> per day or a peak flow rate .056 litres per second under the following conditions:

- UV dosage is greater than 5mJ/cm<sup>2</sup>
- Suspended Solids – less than 30 mg/litre
- BOD (5 days) – less than 30 mg/litre
- If the effluent is cleaner than the above figures the level of treatment is greater

From the above conditions, the faecal coliform reduction by the Marsh:UV Disinfection Unit exceeds 99.9% or 3-logs, at the end of UV lamp life, which is two years of continuous operation.

Figure 2 below provides an indication of the UV dosage requirements in order to provide a 90-99% reduction in different strains of coronavirus.

Technical details and specifications available at [www.marshindustries.co.uk](http://www.marshindustries.co.uk).



## Distribution boxes

Polylok D-box: 4 hole and 7 hole

Used as part of a larger wastewater treatment system, a distribution box is a component which helps to process the flow of effluent as it moves into a drainage field or water course.

Manufactured from polypropylene, the boxes are lightweight, strong and durable, creating a versatile unit with multiple inlet and outlet configurations to suit any site condition.

Available as a 4 hole or 7 hole box, the units can accommodate any type of pipework ranging in diameter from 110-160mm and are supplied with appropriate seals.

Stabilizing feet are moulded into the base of the boxes to anchor the units in place.

## Benefits

- Light weight, strong and durable
- Multiple inlet and outlet positions
- Easy fitting and installation
- Can accept a variety of pipes from 110-160mm
- Unique D-box pipe seal and nut (seals can be used as a stopper)
- Optional risers available to suit individual site conditions
- Can be supplied with 'Roto-Flow' liquid levellers



## Poly-Air carbon vent

Designed for foul pipework, septic tanks and domestic sewage treatment plants, the Poly-Air activated carbon vent filter removes offensive odours as they exit the sewer pipe network through vent pipes.

Every building with a sink, toilet, bath or shower has a network of sewer pipes to remove wastewater. Odours from this pipe network (and septic tanks) are often a nuisance problem and when they occur can be particularly unpleasant.

All sewer pipe networks and septic tanks should have vent pipes installed to allow pressure to equalise as wastewater flows from a sink, toilet or other source. Without vent pipes, flow would be compromised.

Under normal conditions, vented air is directed to the outside of the building and dispersed. However, events can occur where the wind outside redirects odour from the vent pipe back towards an occupied area of the building.

Installing a Poly-Air activated carbon vent filter removes offensive odours, such as Hydrogen Sulphide, as they exit the vent pipes.

## Benefits

A single UV maximum flow through the unit is rated at 16m<sup>3</sup> per day or a peak flow rate .056 litres per second under the following conditions:

- Fits standard vent pipe sizes
- Easy to install
- Easy to replace the activated carbon
- No offensive odours
- Cost effective



## Ant-flood kits

Designed for foul pipework, septic tanks and domestic sewage treatment plants, the Poly-Air activated carbon vent filter removes offensive odours as they exit the sewer pipe network through vent pipes.

### Elevated compressor housing

Marsh Industries' elevated compressor housing protects sewage treatment plant electrical components from water ingress due to flooding or water seepage.

Manufactured with a green gelcoat finish, the raised housing is available in 1 and 1.5m heights and is supplied with an IP rated waterproof plug and sockets. The housing is also vented to allow even distribution of air to the compressor.

Compressors provide diffused air to an aeration chamber within a package sewage treatment plant. Aerobic bacteria (biomass), supported by diffused air and mobile media, breaks down solids and increases oxygen which reduces ammonia levels in the effluent before discharge.

*Note: When ordering the elevated compressor housing, please contact our technical team for accurate compressor sizing..*

### Impermeable lid

Marsh Industries has developed an impermeable lid for wastewater systems which prevents water ingress due to flooding or water seepage.

The green lid, with its wrap-around cover and anti-skid embossing, covers a 600x600mm opening allowing easy access to internal chambers for maintenance and desludging. It is supplied with lock down bolts and has a working load of 1.5 tonne.

*Note: Heavier duty lids are available. Please contact Marsh Industries for further details.*

### 110mm/160mm non-return valves

These unique non-return valves protect sewage treatment plants by preventing floodwater from moving up the drainpipes from overflowing rivers, ditches or watercourses.

The valves also benefit from a stainless steel backing which prevents rodents from entering the plant during a flood event.

*Note: Larger diameter valves are available. Please contact Marsh Industries for further details.*

# Sewage treatment

## General guidance as provided by environmental regulators

As stated in this brochure, for development proposals in sewered areas it is usually a legal requirement to connect to the public sewer, either by gravity or pumping, as the sewage is conveyed to a municipal sewage treatment works.

However, if it can be demonstrated that the proposed sewage disposal system offers a more sustainable solution to the overall water management of the site, then the regulators will consider the installation of a 'private' system.

For any such proposal you should:

- Check with your regulating body to confirm current status with regard to Registration/Consent, quality and volume limits, etc
- Take account of the requirements of Building Regulations and discuss with the local planning authority at an early stage - well before any planning application is made

## Drainage fields

If you have access to a suitable area of land, discharge from your septic tank or treatment plant to a properly designed and sized drainage field is the best environmental option as the treated effluent recharges groundwater, nutrients are retained in the soil, and nutrient loads on surface waters are reduced.

The most common form of drainage field is a subsurface percolation area comprising perforated infiltration pipes laid in shingle-filled trenches – normally within 1m of ground level to allow the micro-organisms in the soil to break down the organic matter, and at least 1.2m above the winter water table.

The drainage field has two principal purposes:

- 1 To allow percolation of partially treated/treated effluent to ground at a controlled rate
- 2 To allow further treatment of partially treated effluent before it reaches the groundwater level

Before you can dispose of effluent via a drainage field you first need to assess whether such a route is appropriate, ie, you have a good depth of well-drained, well-aerated soil away from watercourses, wells/boreholes, dwellings, and avoiding sloping sites and areas prone to waterlogging.

### Trial hole and percolation test method (See figure 1)

To calculate the exact area of land required for effective disposal an 'assessment' is required, usually by performing a percolation/water table test as outlined in BS6297 (Code of Practice for the Design and Installation of Drainage Fields for use in Wastewater Treatment) and the latest version of Building Regulations: H2.

A **trial hole** should be dug to determine the position of the standing groundwater table a minimum of 1m<sup>2</sup> in area and 2m deep, or a minimum of 1.5m below the invert of the proposed drainage field pipework. The groundwater table should not rise to within 1m of the invert level of the proposed effluent distribution pipes. If the test is carried out in summer, the likely winter groundwater levels should be considered.

A **percolation test** should then be carried out to assess the further suitability of the proposed area. A hole 300mm square should be excavated to a depth 300mm below the proposed invert level of the effluent distribution pipe. Where deep drains are necessary the hole should conform to this shape at the bottom, but may be enlarged above the 300mm level to enable safe excavation to be carried out.

Fill the 300mm square section of the hole to a depth of at least 300mm with water and allow it to seep away overnight.

Next day, refill the test section with water to a depth of at least 300mm and observe the time, in seconds, for the water to seep away from 75% full to 25% full level (ie, a depth of 150mm). Divide this time by 150. The answer gives the average time in seconds ( $V_p$ ) required for the water to drop 1mm.

The test should be carried out at least three times with at least two trial holes and the average figure from the tests should be taken. The test should not be carried out during abnormal weather conditions such as heavy rain, severe frost or drought.

Drainage field disposal should only be used when percolation tests indicate average values of  **$V_p$  of between 12 and 100**. This minimum value ensures that untreated effluent cannot percolate too rapidly into groundwater. Where  $V_p$  is outside these limits effective treatment is unlikely to take place in a drainage field.

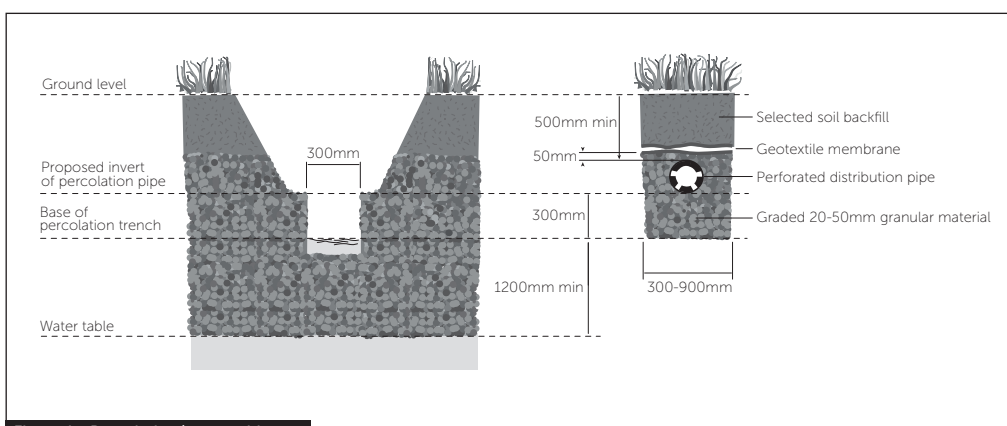

Figure 1 - Percolation/water table test

### Note:

- > The phrase 'soakaway' is often used in relation to septic/treatment plant discharges. However, the purpose of a 'soakaway' is to distribute surface water to ground as quickly as possible and does not provide the required features of a drainage field.

### Drainage field construction (See figures 1 and 2)

Drainage fields should be designed and constructed to ensure aerobic contact between the liquid effluent and the subsoil using perforated pipe laid in trenches:

- Pipes should be laid on a 300mm layer of clean shingle or broken stone (graded between 20mm and 50mm) at a minimum depth of 500mm and a uniform gradient not steeper than 1:200
- Trenches should be filled to a level 50mm above the pipe and covered with a layer of geotextile to prevent the entry of silt. The remainder of the trench can be filled with soil
- Trenches should be from 300mm to 900mm wide with areas of undisturbed ground 2m wide being maintained between parallel trenches.
- An inspection chamber should be installed between the septic tank and the drainage field
- Drainage fields should be set out as a continuous loop fed from the inspection chamber

To calculate the floor area of the drainage field ( $A_t$  in  $m^2$ ), the following formulas should be used:

$$\text{For septic tanks: } A_t = p \times V_p \times 0.25$$

$$\text{For treatment plants: } A_t = p \times V_p \times 0.20$$

Where  $p$  is the number of persons served by the tank and  $V_p$  is the percolation value (secs/mm) obtained.

If it is not possible to discharge to a drainage field but you can discharge to a watercourse, coastal water or surface water sewer you should consider installing a package sewage treatment plant to treat sewage to a sufficient standard as to allow direct discharge to the receiving waters.

## Tank sizing

The size of sewage treatment system you will require depends on the number of people that occupy the site and their activities, and it is at this stage you should re-contact Marsh.

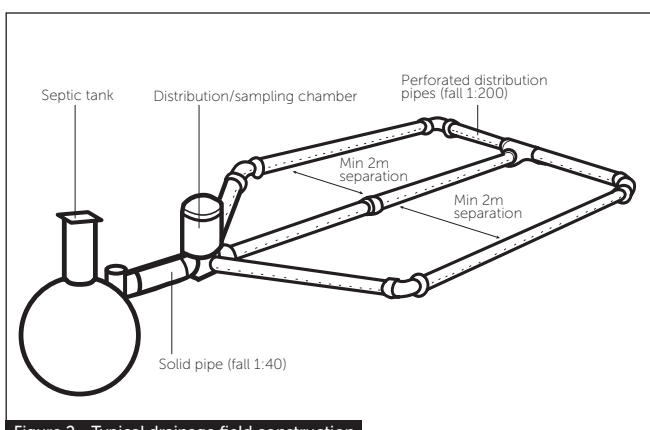

Figure 2 - Typical drainage field construction

You will need to provide detailed information about the sewage to be treated and its disposal method to enable calculation of the size of plant you will need. It is essential that you give accurate information as incorrect specification may result in the system you are provided with being inadequate and not treating the sewage effectively, leading to foul smells and possible pollution.

## Distance from properties

Guidance collated from several sources recommends the following:

Distance from	Dwelling	Watercourse	Borehole/well
<b>Pump chamber:</b>			
1-5 dwellings	5m	-	-
6-20 dwellings	10m	-	-
20+ dwellings	15m	-	-
<b>Septic tank</b>	7m	10m	50m
<b>Treatment plant</b>	7m	10m	50m
<b>Cesspool</b>	7m	10m	50m
<b>Drainage field</b>	15m	10m	50m

## Desludging

Sewage treatment is an ongoing process and the micro-organisms must stay healthy for the system to work. You should desludge the system regularly (usually annually or in line with manufacturer instructions) to prevent the build-up of sludge and solids to ensure sewage flows freely through the unit. It is recommended that not all sludge is removed as it can act as an anaerobic seed.

Tanks should be inspected monthly to check they are working correctly – the inlet chamber should be free-flowing and the effluent from the outlet should be free-flowing and clear.

Where emptying is by tanker, siting within 30m of suitable vehicle access point is recommended.

### Notes:

- > Septic tanks can only discharge to ground via a drainage field – discharge to a watercourse (stream, ditch, pond) is not allowed.
- > Drainage fields are not permitted in Zone 1 groundwater protection zones.
- > No underground services or access roads/driveways/paved areas should be located in the disposal area.
- > Discharge from a sewage treatment plant requires a smaller (20% less) drainage field than a septic tank for effective treatment.
- > Elevated drainage mounds can provide an alternative to drainage fields in certain circumstances as they provide an aerated layer of soil where a conventional drainage field is inappropriate due to occasional waterlogging.

# Marsh Industries

Providing world-class water and wastewater treatment solutions to the domestic, commercial and agricultural sectors from our UK manufacturing plants in Kettering, Raunds and Bridgwater.

## Working smarter

### Efficiently meeting the needs of our customers

We strive to be recognised as a collaborative and trusted partner for our customers, aligned to their business, and with a reputation for providing quality products that really do add value.

## Innovative thinking

### Enabling technologies that deliver tangible benefits

Working across many areas of the UK construction sectors our specialist innovation team combines 100+ years' experience of designing, manufacturing and testing wastewater treatment products that are proven to be economic, efficient and environmentally sensitive.

## Compliant products

### In line with building and environmental regulations

Our products are fully type-tested and certified to ensure compliance with relevant environmental permitting programmes and Building Regulations. Our extensive portfolio of product approvals and certification is available for viewing.

## Delivering confidence

### Extensive civils knowledge and experience

Customers specify Marsh products and services because they know we deliver from a solid foundation of knowledge, experience, product quality and proven performance.

## Supporting your business

### Specialist services to further enhance customer requirements

There are times when our customers need a little extra support. Whether this is on-site advice, backup support, specialist testing or bespoke project solutions, we offer a range of services when and where required.

## Together we are a strategic partnership

Our core strength lies in the knowledge, experience and enthusiasm of our staff and our customers combined.



NBS Source  
PARTNER



**MARSH HQ AND FACTORIES**  
Units 2-20, Addington Business Park  
Little Addington, Northamptonshire  
NN14 4AS

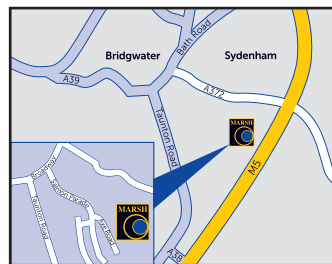

**BRIDGWATER FACTORY**  
Axe Road, Colley Lane Industrial Est.  
Bridgwater, Somerset TA6 5LN

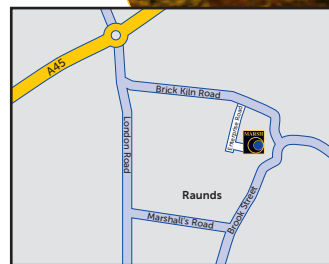

**RAUNDS FACTORY**  
Enterprise Rd, Raunds,  
Northamptonshire NN9 6JE

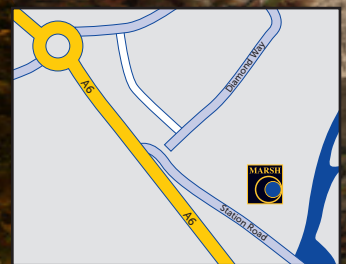

**MARSH CIVILS OFFICE**  
Waterside House, Station Rd,  
Irthlingborough,  
Northamptonshire NN9 5QF

[sales@marshindustries.co.uk](mailto:sales@marshindustries.co.uk)  
+44 (0)1933 654582  
[www.marshindustries.co.uk](http://www.marshindustries.co.uk)

