

REVISION NOTES

Rev	Date	Description	Drw	Chk
-----	------	-------------	-----	-----

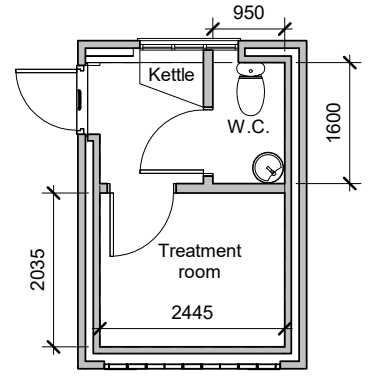

1 **0 Ground Floor FFL**
1 : 100

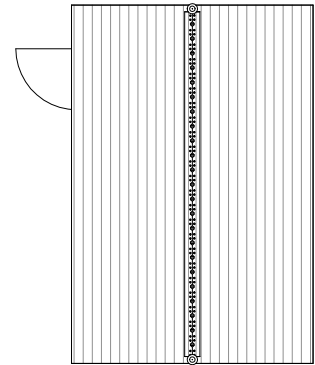

2 **4 Roof Plan**
1 : 100

0 **Block Plan**
1 : 1250

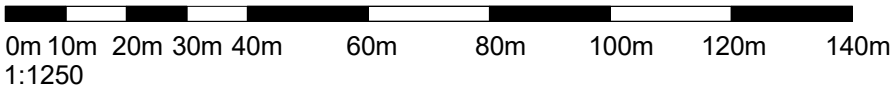

0m
1:100

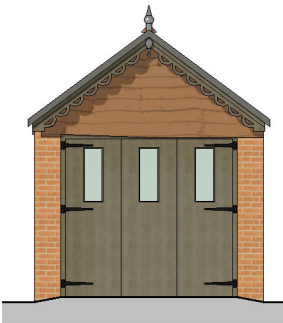

3 **South Elevation**
1 : 100

5m

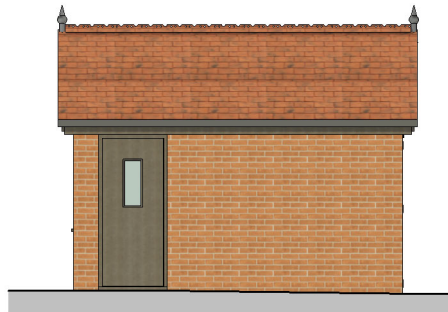

4 **West Elevation**
1 : 100

10m

15m

Option 1 Retain Garage doors as Architectural Features



WLAWilliamsLester.

1 Star Lane, Ringwood, BH24 1AL
www.williamslester.com 01425 485234 mail@williamslester.com

Client

Ms Britney Mason

Project

Garage, Henderson Crt
High Street, Lymington, SO41 9AQ

Title

Proposed Plans and Elevations

Scale A4 @ As indicated

Revision Drawing Status

Proposed

Suitability Suitability Description

- **For Planning**

Drawing No.

6222-WLA-ZZ-XX-DR-A-0020

5 **North Elevation**
1 : 100

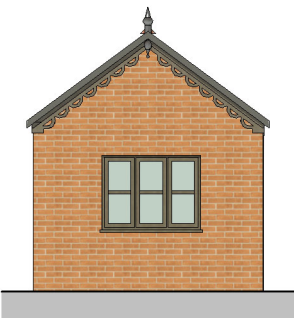

6 **East Elevation**
1 : 100

