



Tree Survey

In accordance with BS5837:2012:
Trees in relation to Design, Demolition,
and Construction - Recommendations

Proposed Care Home and Supported Living Accommodation Pothouse Lane Stocksbridge

Paul Hicking Associates

12 Beaurepaire Crescent, Belper
Derbyshire. DE56 1HR
t: 01773 827727 m: 07856 729813
e: paul@hicking.plus.com

**PROPOSED CARE HOME AND SUPPORTED
LIVING ACCOMMODATION AT
POTHOUSE LANE
STOCKSBRIDGE**

EXISTING TREE SURVEY REPORT

(November 2023)

REPORT REF: 2355- PHA

CLIENT: Millhouse Care

ECOLOGIST: Paul Hicking Associates
12 Beaurepaire Crescent
Belper
Derbyshire
DE56 1HR



Report Prepared By:

.....
Paul Hicking
Director 28th November 2023

Report Checked By:
.....
Paul Hicking FdSc
Director 28th November 2023

COPYRIGHT

The contents of this document must not be copied or reproduced in whole or part without the written consent of Paul Hicking Associates

Contents

Summary	4
Introduction	5
Arboricultural Impact Assessment.....	5
Site Description.....	5
Environmental Assessment	5
Arboricultural Impact Assessment.....	5
Trees and Wildlife.....	7
Legislation	8
Assessment Principles.....	9
Arboricultural Method Statement - Design Stage.....	12
Recommendations.....	17
References.....	17
APPENDIX 1 – SCHEDULE OF SURVEYED TREES	18
APPENDIX 2 – PLAN OF SURVEYED TREES	20

SUMMARY

This report is concerned with trees located within the immediate vicinity of the proposed care home and supported living accommodation at Pothouse Lane, Stocksbridge.

The report and accompanying tree survey schedule is produced in accordance with the guiding principles of British Standard 5837:2012 '*Trees in relation to Design, Demolition and Construction – Recommendations.*'

The Root Protection Area (RPA) of the trees surveyed are calculated and recorded in the Tree Survey Schedule where they are expressed in linear metres; it is this distance/around this area that tree protective barriers should be erected around any trees to be retained. Where construction is proposed within these areas special techniques should be employed and general guidance is contained herein.

This report provides guidance for the design team and sets out the constraints relating to the trees on site. Tree survey and RPA details can be found in the Tree Survey Schedule and drawing ref: 2355-01.

INTRODUCTION

Paul Hicking Associates were appointed by Another Kind Architects on behalf of Millhouse Care to prepare a report in line with BS 5837:2012 - Trees in relation to Design, Demolition, and Construction. A site survey was carried out on 4th July 2023 to assess the condition of the existing trees and to determine any arboricultural implications or works required in relation to the proposed care home and supported living accommodation at Pothouse Lane, Stocksbridge.

ARBORICULTURAL IMPACT ASSESSMENT

SITE DESCRIPTION

The development site is located and accessed off Pothouse Lane, within the town and civil parish of Stocksbridge in south Yorkshire. Formerly known as 'Pot House' his c0.6022ha irregular shaped site comprises of a single dwelling with a hardstanding drive, amenity grassland forming a front lawn and a large area of poor semi-improved neutral grassland and tall ruderal herb formerly used as a small holding for the rearing of chickens and egg production. There are also a number of scattered trees and tree lines within the site and along the boundary. Boundaries are enclosed by traditional stone walling and the rear gardens of adjacent properties.

The development proposals comprise of the construction of a new care home for up to 90 residents and supported living accommodation for up to 29 residents with associated hard and soft landscaping.

ENVIRONMENTAL ASSESSMENT

The trees, groups and hedgerows which are the subject of this report are located within the development site or the rear gardens of the adjacent dwellings and comprise of a mixture of native deciduous and non-native coniferous species. All trees are considered high in ecological value due to their age range and contribution to local biodiversity and their ability to support a variety of wildlife.

ARBORICULTURAL IMPACT ASSESSMENT

All trees surveyed vary in age and maturity and are of fairly good health and condition. These trees have not been subject to regular management leading to some bias directional growth structure. The trees would benefit from some light management to remove deadwood.

There are currently 26no. individual trees, 4no. tree groups and 6no. hedgerows within the site or within in close proximity to the proposed development and comprise of the following:

Schedule of existing trees.

Category	Tree number	Totals
B2	T1, T2, T3, G12, T22, T25	6
C2	T4, T5, G6, T7, T8, T9, T10, H11, T13, H14, T15, H16, T17, T18, T19, T20, T21, T23, H24, G26, T27, H29, T30, H31, T32, T33, T34, T35, T36.	30

Tree retention and removals – impact of the proposed development.

A fully detailed scheme for the development is not yet in place and therefore this report aims to provide guidance for the proposed design. Trees along the boundary of the site are likely to be retained and are of best quality. Where possible the Mature Field maples (*Acer campestre*), should be retained.

All trees which are to be retained are to be protected in accordance with B.S. 5837 : 2012 during the site clearance and construction works using 1.8m high Heras fencing set out along the line of the RPA or canopy of the tree whichever is the greater.

Tree Preservation Order (TPO) – No trees within the site or adjacent gardens are the subject of a Tree preservation Order.

Trees and Wildlife

Bats - Trees can play host to roosting bats, all of which are protected by law.

All trees were assessed from the ground to search for the presence of features which could provide potential for bats such as splits, cracks, rot holes, coverings of ivy, peeling bark or similar. The potential for the trees to support roosting bats will be ranked in accordance with the criteria set out in the publication entitled 'Bat Surveys – Good Practice Guidelines,' by the Bat Conservation Trust (BCT):

Any trees of interest were identified and recorded for further investigation. Tree assessments may produce one of several outcomes that are categorised below:

- **Roost:** Direct or indirect evidence of bats was observed during the tree assessment. Ecologist involvement will be required that may require further survey work that should be undertaken at suitable times of the year. Additional surveys can be used to inform European Protected Species licence (EPS) from the local Statutory Nature Conservation Organisation (SNCO) if the proposed development is considered likely to cause an offence.
- **Category 1* (High Potential):** No evidence of bats was observed but the potential for bats is very good due to a variety of suitable features, good conditions and / or surrounding habitat or known bat roosts located within close proximity of the site. This category of trees is generally considered capable of supporting larger roosts than Category 1. Ecologist involvement is required.
- **Category 1 (Moderate Potential):** No evidence of bats was observed but the definite potential for bats due to a limited number of suitable features within the tree(s). This category of trees is generally capable of supporting single bats. Further ecologist involvement is considered likely to be required, and precautions should be taken including a method statement outlining best practice guidelines and procedures in case new evidence is found e.g. soft felling, avoidance wherever possible.
- **Category 2 (Low Potential):** No evidence of bats was observed and potential for bats being present is considered unlikely. Crevices or cracks may be found but have limited potential for bats. Further ecologist involvement not considered necessary.
- **Category 3 (No Potential):** No evidence of bats was observed and potential for bats being present is considered negligible. No further action is considered necessary.

Trees that have been identified as Roost, Category 1* or Category 1 may require further investigation, including aerial tree surveys. Once trees have been aerially surveyed, they may be re-categorised as higher or lower risk.

2no ., trees were identified with the potential to support roosting bats at this time. T4 and T20 contain features with low to moderate potential to support roosting bats and were categories 1 and 2. All other trees surveyed were identified as Category 3 without potential to support roosting bats.

Birds – Trees play host to nesting birds and their nests are protected by law during the bird breeding season. All trees identified within this report have the potential to support breeding birds. To avoid a breach of the legislation, works to trees are to be carried out outside of the bird breeding season, which normally runs from mid-March to September inclusive. If it is necessary to carry out work during the bird breeding season, then a thorough search of the areas to be affected should be carried out by a suitably qualified ecologist prior to starting the works. If any active nests were found, works should stop until all chicks have fledged.

Legislation

Bats – All bat species are afforded full protection under UK and European legislation, including the Wildlife and Countryside Act 1981 (as amended), Countryside Rights of Way (CROW) Act 2000 and The Conservation of Habitats and Species Regulations 2010 (as amended). Together, this legislation makes it illegal to:

- Intentionally or deliberately take, kill or injure a bat;
- Damage or destroy or obstruct access to bat roosts; and
- Deliberately disturb bats.

Birds – The bird breeding season generally lasts from early March to September for most species. All birds are protected under the Wildlife and Countryside Act 1981 (as amended), Countryside Rights of Way (CROW) Act 2000. This legislation makes it illegal, both intentionally and recklessly to:

- Kill, injure or take any wild bird.
- Take, damage or destroy the nest of any wild bird while it is being built or in use.
- Take or destroy the eggs of any wild bird; and
- Possess or control and wild bird or egg unless obtained legally.

Birds listed under Schedule 1 of the Wildlife and Countryside Act 1981 (as amended) are afforded additional protection, which makes it an offence to disturb a bird while it is nest building, or at a nest containing eggs or young, or disturb the dependent young of such bird.

Tree preservation Orders: It is an offence to cut down, lop, uproot, wilfully damage or destroy tree subject to a tree preservation order (TPO) without the issuing planning authority's permission.

ASSESSMENT PRINCIPLES

The survey has been carried out using the principles of British Standard 5837:2012 - Trees in relation to Design, Demolition, and Construction.

The trees have also been assessed in terms of their quality, health and their landscape value to the local environment and any proposed development of the site area. Tree works required to retain trees have been proposed based on arboricultural requirements only at this initial stage.

Survey Methodology and Limitations

Survey timing - The survey was carried out at a time to aid the design process of the new development.

Topographical survey - A topographical survey was made available for the site. This survey was provided in a CAD format and includes the position of all significant trees and hedgerows on or immediately adjacent to the site. The survey also includes all other landscape features such as the position of existing buildings and structures, pathways and access roads. Changes in ground levels were also recorded on the survey and are related back to known ordinance survey levels and co-ordinates.

All trees have been inspected visually only. No survey work has been carried out to determine the internal condition of any trees. Further investigations can be made and will be recommended where considered necessary but are beyond the scope of this report.

Trees with a diameter greater than 75mm have been surveyed. The location of any below ground services has not been investigated within this report.

We have inspected all the trees that would be influenced by the development proposals. Their reference number and canopy spread are shown on drawing nos. 2355-01 Existing Tree Survey and Root Protection Areas.

Site survey and recording - A full site walkover survey was carried out. Using a copy of the topographical survey and the position of all trees was reconfirmed and updated accordingly. There was adequate access to all trees and no ground vegetation clearance was required to allow the survey to be carried out.

Assessments of condition of trees were only done visually from the ground. Due to mapping limitations some inaccuracies in relative position of features on the plan may exist. Therefore, all measurements for root protection areas should be taken directly from the trees themselves.

The following survey information was gathered from each tree to allow a comprehensive schedule to be produced:

- Species identification – recorded as common name and/or scientific name.
- Crown height – recorded to the nearest 0.5m up to 10m and nearest 1.0m for dimensions over 10m.

- Stem diameter - each tree was measured using a diameter/circumference tape at a height of 1.5m above finished ground level (DBH), to allow the root protection area to be calculated. All dimensions were recorded in millimetres.
- Branch spread at four cardinal points – recorded to the nearest 0.5m up to 10m and nearest 1.0m for dimensions over 10m.
- Life stage (e.g. young, semi-mature, early mature, mature, over mature).
- Estimated remaining contribution, in years (<10, 10+, 20+, 40+).

All trees were given an identification number and were recorded using the following colour coding to identify their assigned retention category:

Category A. Trees of high quality with an estimated remaining life expectancy of at least 40 years.

Category B. Trees of moderate quality with an estimated remaining life expectancy of at least 20 years.

Category C. Trees of low quality with an estimated remaining life expectancy of at least 10 years, or young trees with a stem diameter below 150mm.

Category U. Those in such a condition that they cannot realistically be retained as living trees in the context of the current land use for longer than 10 years.

Colour coding as Table 2 BS 5837: 2012.

Sub-categories

1 = Mainly arboricultural qualities

2 = Mainly landscape qualities

3 = Mainly cultural values

Trees were also assessed for their condition as follows:

- Good - trees in apparent good condition with no obvious defects.
- Average- trees apparently in fairly good condition or with defects that could be corrected by good tree surgery.
- Poor - trees in poor condition with significant defects or in obvious decline.

Deadwood was assessed as follows:

- Light - less than 50mm diameter.
- Minor - less than 100mm diameter.
- Major - greater than 100mm diameter.

Tree Retention Strategy:

- To comply with legislation for the protection of trees subject to a Tree Preservation Order and/or within a Conservation Area where applicable.
- To promote good arboricultural practice.
- To introduce where possible good arboricultural practice to maintain the health of existing trees.
- To protect existing trees during the construction period
- To facilitate and inform the design proposals.

ARBORICULTURAL METHOD STATEMENT - DESIGN STAGE

The most susceptible part of a tree to damage is its root system, which because it is underground, out of sight, it is frequently ignored. Damage or death of the roots will affect tree health, growth, life expectancy and safety. The ability of a tree to tolerate some disturbance and alteration of its growing conditions depends on specific circumstances, including prevailing site conditions, and in general, the older the tree, the less successfully it will adapt to new conditions.

The majority of tree roots live in the top 600mm of top soil and as such are particularly vulnerable during initial construction activity, soil stripping etc. Damage to the soil structure may result in changes in moisture, oxygen availability and carbon dioxide dispersal. This can lead to anaerobic conditions and root death. Root damage can result in instability or premature decline which may not manifest for a number of years, often long after development has been completed.

Tree Roots are dynamic structures which constantly 'seek' new soil horizons which are conducive to their function and development; new roots can develop in these horizons whilst roots in less productive horizons might be aborted. Consequently, in general terms, trees will tolerate some construction related root disturbance if:

- The tree has sufficient vigour/vitality to sustain the disturbance in the short term
- Any disturbance is kept to a minimum and special techniques are adopted to ensure such
- Alternative soil horizons are available/can be created within which roots can develop and flourish.

In order to protect the soils and the roots that live in them strong protective fencing is vital. Whilst BS 5837: 2012 gives recommended distances to protect tree health the aim should be to protect as large an area as possible. It should allow for all site activities, so excluding service trenches and soakaway's, storage as well as actual construction activities.

Tree Protection Plan

The location of root protection areas is shown on drawing nos. 2355-01 Existing Tree Survey and Root Protection Areas. However, a further pre-construction phase plan will be required for the approval by the Local Planning Authority Tree Officer to confirm the following:

- Locations of all site accommodation.
- Site construction access.
- Construction staff parking.
- Materials storage areas including the location of materials storage hoppers.

- Specialist work areas including areas for the mixing of materials, location of cranes, plant and scaffolding.
- Construction zones for foundation excavation (including landscaping features).
- Final locations of protective barriers.
- Location of temporary new and temporary service runs.
- Location of temporary materials storage such as spoil heaps etc.
- Location of new and temporary access roads.
- Construction works phasing.
- Final location of all protective fencing.

Tree Protection Sequence

The following sequence of events should be followed during the development process to ensure tree protection and survival is possible.

Prior to development

- Carry out any tree removal by specialist contractor in accordance with B.S. 3987 : 2020.
- Install protective fencing. Existing 2.0m boundary fencing to be retained to protect stem of trees within adjacent gardens with additional 1.8m high Heras fencing to protect RPA and canopy overhanging boundary.

During construction

- Retain protective fencing – all protective fencing to be retained throughout development unless variation agreed by appointed project arboriculturist.
- No construction related activity to take place within the construction exclusion zone without the express consent of the appointed project arboriculturist and LPA Arboricultural Officer. Where works are required they are to be kept to a minimum and restricted to the working zones required.

Post construction

- Fencing to be removed.
- Arboricultural assessment to determine further tree surgery or arboricultural remediation in light of final construction.

Root Protection Areas

Trees to be retained will require protection throughout the duration of the proposed development with protective fencing and signage (see Fig. 1 and 2 below). To ensure retention of adequate protection throughout the development process, regular site monitoring should be carried out on a formal and agreed

basis to report on the condition and status of protective fencing and other methods. Protection methods should also give due consideration to the movement of site vehicles and the movement of construction materials to avoid collision with tree canopies.

Where necessary, a root protection area was calculated for each tree in accordance with BS 5837:2012. Drawing Nos. 2355-01 Existing Tree Survey and Root Protection Areas provides details of the extent of calculated RPA. Protective barriers are to be placed around these areas or beyond the line of the canopy, whichever is the greater.

It must be ensured that wide or tall loads or plant with booms, jibs and counterweights can deliver or operate without coming into contact with retained trees above the fencing line of the construction exclusion zone. Such contact can result in serious damage to the trees and might make their safe retention impossible. Any transit or traverse of plant in close proximity to trees should be conducted under the supervision of a banksman to ensure that adequate clearance from trees is maintained at all times. In some circumstances it may be possible to maintain adequate clearance thus necessitating access facilitation pruning.

Fig. 1. Example of protective fencing and signage:



Fig. 2. Protective fencing for tree root protection:

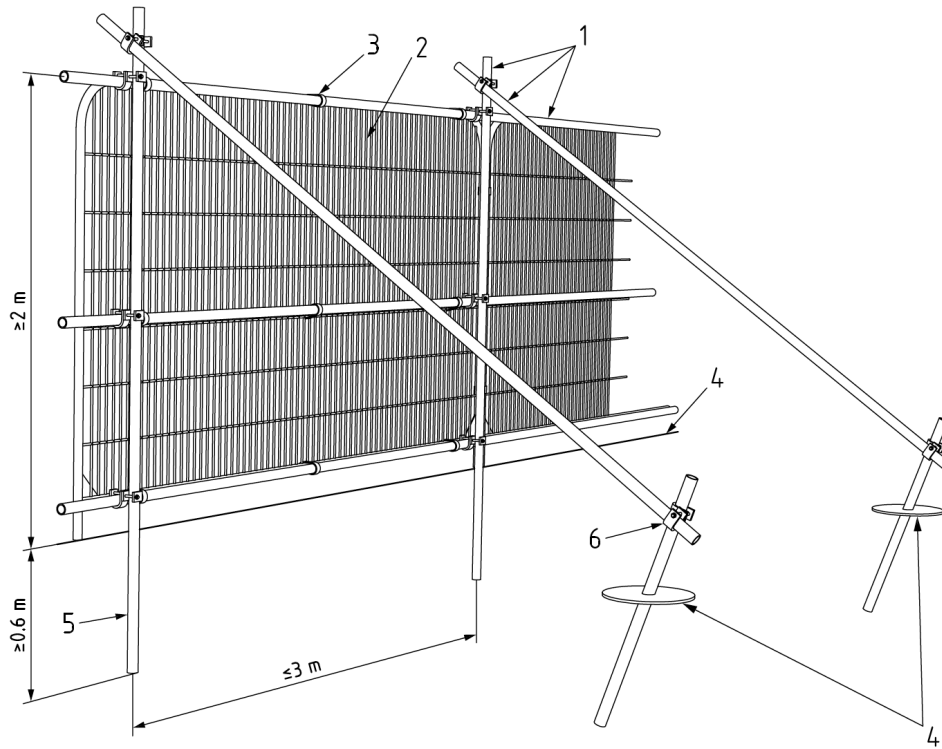

Key

- 1 Standard scaffold poles
- 2 Heavy gauge 2 m tall galvanized tube and welded mesh infill panels
- 3 Panels secured to uprights and cross-members with wire ties
- 4 Ground level
- 5 Uprights driven into the ground until secure (minimum depth 0.6 m)
- 6 Standard scaffold clamps



Scaffold Board Ground Protection Ground protection where works are in close proximity to tree roots

Construction Stage Arboricultural Method Statement

Care must be taken when carrying out tree pruning work. This work is to be carried out in a careful and methodical manner to ensure protection of retained branches.

The mixing of mortars, concrete and cement based products or the washing down of these areas should not be carried out within the vicinity of root protection areas as these may adversely affect the soil conditions. Materials which may contaminate the soils including wheel washing should not be discharged within 10m of a tree stem. The slope of the land should also be taken into consideration to avoid damaging materials running towards trees.

Compaction of soils/soft landscaping within close proximity of retained trees is to be avoided as this may affect the porosity of the ground to allow water penetration to tree roots. This may be overcome by laying tree protection boards/matting over the areas of soft landscaping to be unaffected by the works and/or surrounding the root protection area with temporary barrier fencing in accordance with (BS 5837:2012).

Any excavations which have to be undertaken within the root protection area should be carried out carefully by hand, avoiding damage to the protective bark covering larger roots. Roots, whilst exposed, should be wrapped in dry, clean hessian sacking to prevent desiccation and to protect from rapid temperature changes.

Roots smaller than 25mm diameter may be pruned back, preferably to a side branch, using a proprietary cutting tool such as bypass secateurs or handsaws. Roots larger than 25mm should only be severed following consultation with an arborist, as these may be essential to the tree's health and stability.

Prior to backfilling, any hessian wrapping should be removed and retained roots should be surrounded with sharp sand (builders sand should not be used because of its high salt content which is toxic to tree roots), or other loose granular fill, before soil or other material is replaced. This material should be free of contaminants and other foreign objects potentially injurious to tree roots. (BS 5837:2012).

Fires should not be lit in a position where their flames can extend to within 5m of foliage, branches or trunk. This will depend on the size of the fire and the wind direction. It is preferable that the lighting of fires within the site is discouraged.

Services – Details regarding the siting and size of underground services have not been made available, the following is given as general advice: Careful consideration must be given to the siting of underground services e.g. drains, electricity, gas etc. They should ideally not be sited within the RPA; where such is unavoidable; the trench must be hand dug and all roots greater than 25mm diameter must be carefully dug around and left intact. Any roots below this size, where they cannot be retained, must be cut cleanly with pruning tools. If the trench is to remain open for prolonged periods, especially in hot, dry weather, roots must be wrapped in damp

hessian sacking to prevent desiccation. In order that they can assess any impact upon trees it is likely that the LPA will require the submission of details regarding service location and installation methodology prior to the granting of any planning consent. Where drains are to be installed within the rooting zone, particular consideration must be given to their construction; compression joints are not wholly reliable and can allow root ingress.

All new services trenches are to be lined with *Terram Root Guard Plus*.

No machinery will be allowed onto the soil within the root protection areas/construction exclusion zones.

The design of hard surfaces should avoid localised compaction and evenly distribute the carried weight over the whole of the surface width. Construction details should be based on site specific factors and expected loads. The specification for new hard surfaces must be designed by the project engineer in line with these principles and any deviation must be referred back to the appointed project arboriculturist and the Council's Arboricultural Officer.

RECOMMENDATIONS

An auditable system of arboricultural site monitoring should be factored in to the process, this should extend to supervision by an arboriculturist whenever construction activity is to take place within any RPA.

Post construction – It is recommended that the implementation of regular management will maintain structure, health, character of new tree planting and their contribution towards biodiversity.

REFERENCES

Arboricultural Advisory & Information Service, (1996) '*Driveways Close to Trees*'

Arboricultural Advisory & Information Service, (2007) '*Through the Trees to Development*'

British Standard 5837:2012 '*Trees in Relation to Design, Demolition and Construction – Recommendations.*' BSI.

British Standard 3987:2020 '*Recommendations for Tree Work*'. BSI

Lonsdale D., (1999), *Principles of Tree Hazard Assessment and Management*, DETR.

Mattheck, C. (2007), *Updated Field Guide for Visual Tree Assessment*.

Strouts R.G., Winter T.G. (1994), *Diagnosis of Ill Health in Trees*, 2nd Ed., DETR.

APPENDIX 1 – SCHEDULE OF SURVEYED TREES

No.	Common Name Scientific Name	Height (m)	N	E	S	W	Dia. @ 1.5m (cm)	Age	Life Expectancy	RPA (m)	Category	Condition and comments.
T1	Field maple <i>Acer campestre</i>	9	4.0	5.0	4.0	4.0	35	EM	40 + years	4.20	B2	Good condition. Minor deadwood.
T2	Field maple <i>Acer campestre</i>	9	2.0	4.0	3.0	3.0	25	EM	40 + years	3.00	B2	Good condition. Minor deadwood.
T3	Field maple <i>Acer campestre</i>	10	4.0	3.0	4.0	4.0	37.5	EM	40 + years	4.50	B2	Good condition. Minor deadwood.
T4	Willow <i>Salix caprea</i>	12	9.0	8.0	7.0	8.0	58, 67	M	10 + years	10.60	C2	Fair to poor condition. Twin stem at base with major cavities and decay. Recommended removal. Tree contains features with potential to support roosting bats.
T5	Apple <i>Malus domestica</i>	5.5	2.0	3.0	4.0	3.0	42.5	M	10 + years	5.10	C2	Fair to poor condition. Root decay and moderate deadwood.
G6	Willow <i>Salix caprea</i>	6	-	-	-	-	12.5	Y	40 + years	1.50	C2	Fair to Good condition. Tree group located within adjacent garden. See plan for spread and RPA.
T7	Apple <i>Malus domestica</i>	3	1.0	1.0	1.0	1.0	12, 7	EM	40 + years	1.70	C2	Fair condition. Tree located within adjacent garden.
T8	Apple <i>Malus domestica</i>	4.5	3.0	4.0	4.0	4.0	15, 20, 23, 10	M	20 + years	4.20	C2	Fair to good condition. Multi-stem tree located within adjacent garden.
T9	Laburnum <i>Laburnum anagyroides</i>	4	2.0	2.0	2.0	2.0	20, 20	EM	40 + years	3.40	C2	Good condition. Tree located within adjacent garden.
T10	Elder <i>Sambucus nigra</i>	3.5	2.0	2.0	2.0	2.0	5	EM	20 + years	0.60	C2	Fair to good condition. Tree located within adjacent garden.
H11	Hawthorn <i>Crataegus monogyna</i>	1.5	-	-	-	-	7.5	SM	40 + years	0.90	C2	Good condition. Well managed hedgerow within adjacent garden. See plan for spread and RPA.
G12	Spruce <i>Picea abies</i>	15	-	-	-	-	30	EM	40 + years	3.60	B2	Good condition. Tree group located within adjacent land. See plan for spread and RPA.
T13	Cherry <i>Prunus avium</i>	7	3.0	3.0	2.0	1.0	45	M	10 + years	5.40	C2	Poor condition. 50% deadwood
H14	Hawthorn <i>Crataegus monogyna</i>	3	-	-	-	-	10	EM	40 + years	1.20	C2	Good condition. Well managed hedgerow within adjacent garden. See plan for spread and RPA.
T15	Lawson Cypress <i>Chamaecyparis lawsoniana</i>	6	2.0	2.0	2.0	2.0	12.5, 7	SM	40 + years	1.70	C2	Fair to good condition. Tree located within adjacent garden.
H16	Elder and Dogwood <i>Sambucus sp., Cornus sp.</i>	3	-	-	-	-	7.5	EM	20 + years	0.90	C2	Good condition. Hedgerow located within adjacent property. See plan for spread and RPA.
T17	Privet <i>Ligustrum ovalifolium</i>	3	2.0	2.0	2.0	2.0	7.5	SM	20 + years	0.90	C2	Good condition. Located within adjacent garden.
T18	Spruce <i>Picea abies</i>	12	3.0	3.0	3.0	2.0	35	M	40 + years	4.20	C2	Good condition. Located within adjacent garden.

T19	Spruce <i>Picea abies</i>	10	2.0	3.0	3.0	3.0	30	EM	20 + years	3.60	C2	Fair to good condition. Located within adjacent garden.
T20	Sycamore <i>Acer pseudoplatanus</i>	15	6.0	6.0	6.0	6.0	45, 45	M	20 + years	7.60	C2	Fair condition. Twin stem at base. Located within adjacent garden. Tree contains features with potential to support roosting bats.
T21	Fir <i>Pseudotsuga menziesii</i>	8	2.0	2.0	1.0	1.0	15	SM	10 + years	1.80	C2	Fair condition. Located within adjacent garden.
T22	Fir <i>Pseudotsuga menziesii</i>	17	4.0	4.0	4.0	4.0	45	M	10 + years	5.40	C2	Fair to good condition. Located within adjacent garden.
T23	Fir <i>Pseudotsuga menziesii</i>	6	3.0	1.0	1.0	3.0	15	SM	10 + years	1.80	C2	Fair condition. Located within adjacent garden.
H24	Privet <i>Ligustrum ovalifolium</i>	2	-	-	-	-	7.5	EM	40 + years	0.90	C2	Good condition. Well managed hedgerow within adjacent garden. See plan for spread and RPA.
T25	Oak <i>Quercus robur</i>	12	4.0	4.0	4.0	4.0	25	EM	40 + years	3.00	B2	Good condition. Located within adjacent garden.
G26	Elder, Holly <i>Sambucus nigra, Ilex aquifolium</i>	3	-	-	-	-	5	EM	20 + years	0.60	C2	Good condition. Located within adjacent garden. See plan for spread and RPA.
T27	Holly <i>Ilex aquifolium</i>	6	2.0	2.0	2.0	2.0	30	EM	40 + years	3.60	C2	Good condition. Located within adjacent garden.
T28	Laburnum <i>Laburnum anagyroides</i>	5	5.0	2.0	2.0	3.0	20, 10	EM	40 + years	2.70	C2	Fair condition. Located within adjacent garden.
H29	Privet <i>Ligustrum ovalifolium</i>	3	-	-	-	-	7.5	EM	40 + years	0.90	C2	Good condition. Well managed roadside hedgerow. See plan for spread and RPA.
T30	Blackthorn <i>Prunus spinosa</i>	5	2.0	3.0	3.0	3.0	15	EM	20 + years	1.80	C2	Good condition. Moderate deadwood.
H31	Leyland Cypress <i>x Cupressocyparis leylandii</i>	4	-	-	-	-	7.5	SM	40 + years	0.90	C2	Good condition. See plan for spread and RPA.
T32	Plum <i>Prunus cerasifera 'Nigra'</i>	4.5	3.0	3.0	1.0	1.0	12.5	SM	10 + years	1.50	C2	Poor to fair condition. >50% deadwood.
T33	Ash <i>Fraxinus excelsior</i>	5	1.0	1.0	1.0	1.0	7.5	Y	40 + years	0.90	C2	Good condition. Self-sown specimen.
T34	Apple <i>Malus domestica</i>	6	2.0	1.0	2.0	1.0	7.5	EM	10 + years	0.90	C2	Poo Poor to fair condition. >50% deadwood.
T35	Cypress <i>Cupressus sp.</i>	7	1.0	1.0	1.0	1.0	10	SM	40 + years	1.20	C2	Good condition. Variegated variety.
G36	Cypress <i>Cupressus sp.</i>	7	-	-	-	-	10	SM	40 + years	1.20	C2	Good condition. Variegated variety group of trees. See plan for spread and RPA.

APPENDIX 2 – PLAN OF SURVEYED TREES

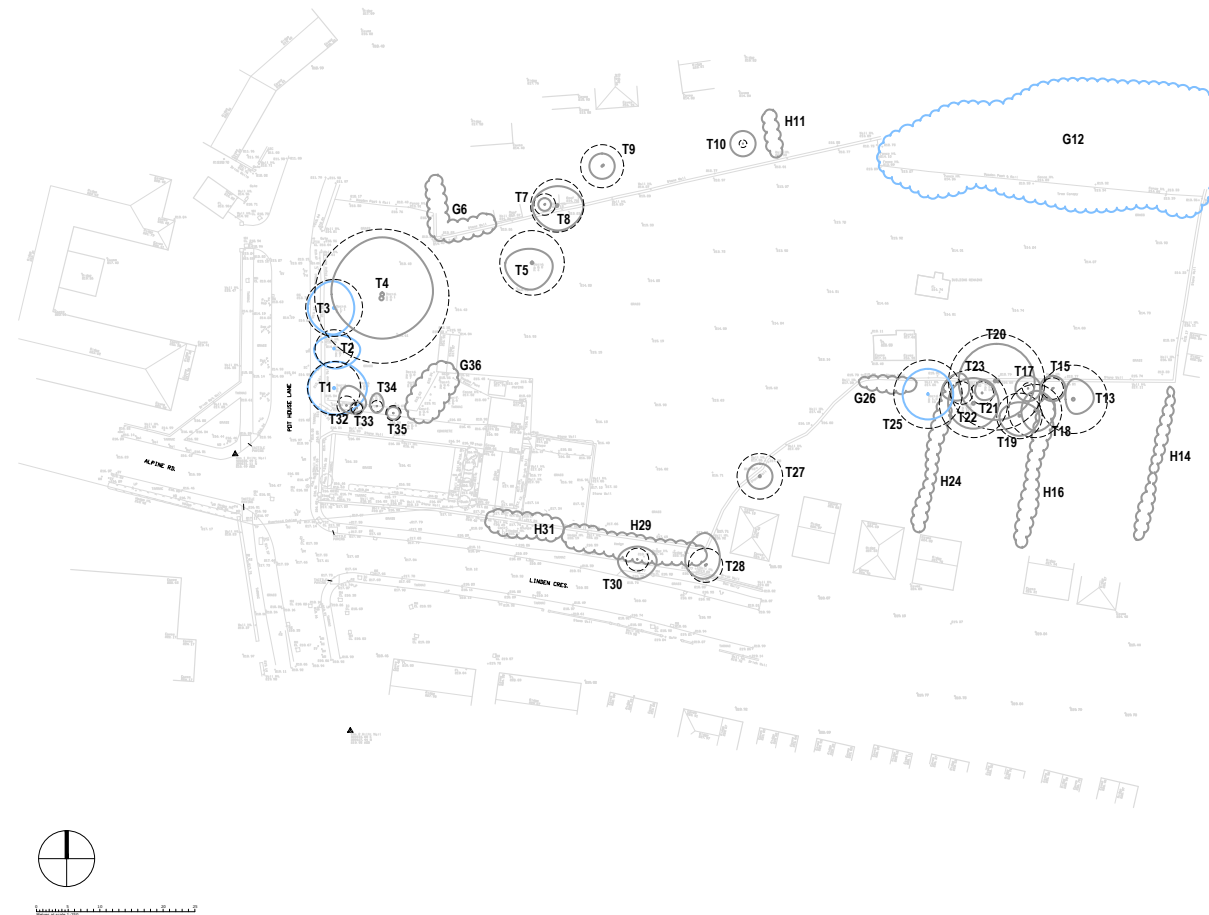

A copy of this drawing is to remain on site at all times

Tree No.	Cat.	Species	Stem dia (cm)	Branch Spread (m)			RPA (m)	RPA (sq) 15'	Height (m)	
				N	E	S				
T1	B2	Field Maple	35	4.0	5.0	4.0	4.20	55	9	
T2	B2	Field Maple	35	2.0	4.0	3.0	3.00	41	9	
T3	B2	Field Maple	37.5	4.0	3.0	4.0	4.50	64	10	
T4	C2	Saltz caprea	58.67	9.0	8.0	7.0	10.60	353	12	
T5	C2	Malus domestica	42.5	2.0	3.0	4.0	3.0	5.10	81	5.5
T6	C2	Malus domestica	12.5	-	-	-	1.50	7	6	
T7	C2	Malus domestica	12.7	2.0	3.0	4.0	3.0	1.70	9.1	3
T8	C2	Malus domestica	15.25 23.10	3.0	4.0	4.0	4.20	55.4	4.5	
T9	C2	Laburnum angustifolium	20.20	2.0	2.0	2.0	3.40	36.3	4	
T10	C2	Elder	5	2.0	2.0	2.0	0.60	1.1	3.5	
H11	C2	Hawthorn	7.5	-	-	-	0.90	3	1.5	
G12	B2	Spruce	30	-	-	-	3.60	41	15	
T13	C2	Cherry	45	3.0	3.0	3.0	5.40	92	7	
H14	C2	Hawthorn	10	-	-	-	1.20	5	3	
T15	C2	Lavison Cypress	12.5, 7	2.0	2.0	2.0	1.70	9.1	6	
H16	C2	Elder Sambucus sp.	7.5	-	-	-	0.90	3	3	
T17	C2	Privet	7.5	2.0	2.0	2.0	2.0	0.90	3	3
T18	C2	Ligustrum ovalifolium	35	3.0	3.0	3.0	4.20	55	12	
T19	C2	Spruce	30	2.0	3.0	3.0	3.60	41	10	
T20	C2	Sycamore	45, 45	6.0	6.0	6.0	7.60	181.5	15	
T21	C2	Prunella	15	2.0	2.0	1.0	1.80	10	8	
T22	C2	Pseudotsuga menziesii	45	4.0	4.0	4.0	5.40	92	17	
T23	C2	Pseudotsuga menziesii	15	3.0	1.0	1.0	3.0	1.80	10	6
H24	C2	Privet	7.5	-	-	-	0.90	3	2	
T25	B2	Oak	35	4.0	4.0	4.0	4.0	3.00	28	12
G26	C2	Elder Sambucus sp.	5	-	-	-	0.60	1.1	3	
T27	C2	Holly	30	2.0	2.0	2.0	3.60	41	6	
T28	C2	Laburnum angustifolium	20, 10	5.0	2.0	2.0	3.0	2.70	22.9	5
H29	C2	Privet	7.5	-	-	-	0.90	3	5	
T30	C2	Blackthorn	15	2.0	3.0	3.0	3.0	1.80	10	5
H31	C2	Leyland Cypress	7.5	-	-	-	0.90	3	4	
T32	C2	Prunella	12.5	3.0	3.0	1.0	1.50	7	4.5	
T33	C2	Ash	7.5	1.0	1.0	1.0	0.90	3	5	
T34	C2	Apple	7.5	2.0	1.0	2.0	1.0	0.90	3	6
T35	C2	Cypress	10	1.0	1.0	1.0	1.20	5	7	
G36	C2	Cypress	10	-	-	-	1.20	5	7	

Schedule of Tree Categories

Category A (Green line): Those of high quality & value; in such a condition as to be able to make a substantial contribution (min 40yrs)

Category B (Blue line): Those of moderate quality & value; in such a condition as to be able to make a substantial contribution (min 20yrs)

Category C (Red line): Those of low quality & value; currently in adequate condition, to remain until new planting established (min 10yrs), or young trees currently with a stem Ø below 150mm

Category U (Black line): Those in such a condition that any existing value would be lost within 10 years and which should in the current context be removed for reasons of sound arboricultural management.

Key Notations

T1 Existing Tree Numbers.

RPA Root Protection Area (RPA)

Revisions:

Notes:
The copyright of this drawing belongs to Paul Hicking Associates and shall not be reproduced without their written consent. Do not scale from this drawing.

12 Beaurepaire Crescent
Belper
Derbyshire
DE56 1HR
T: 07856 729813
E: paul@hicking.plus.com

Pothouse Lane, Stocksbridge
Tree Survey and Root Protection Areas

Drawing No: **2355 - 01** Revision: Scale: 1:250 @ A1 Status: Planning

