

ND-03

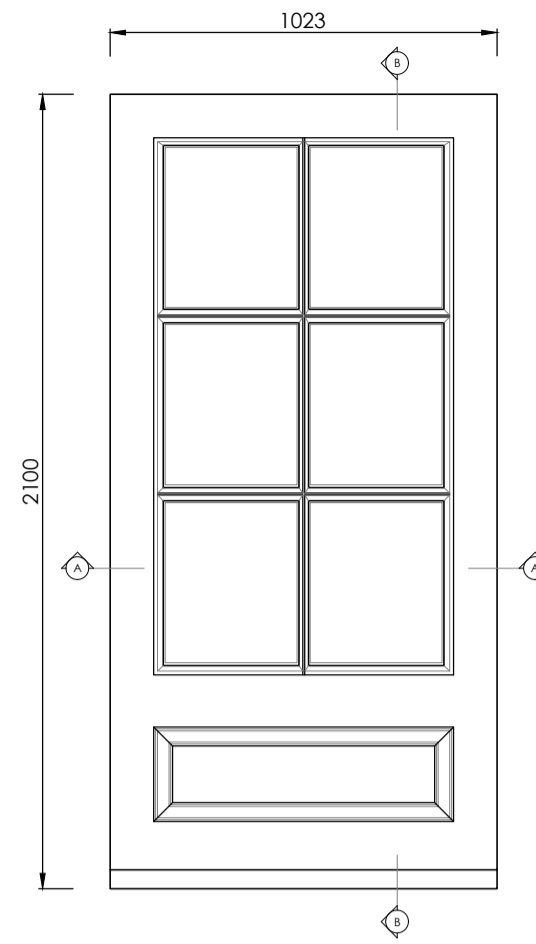

ND-03 - Ground Floor External Door - Double Glazed, Timber Frame by Westbury Windows and joinery.

Elevation 1:20
0 250mm 500mm 750mm 1m 1:20

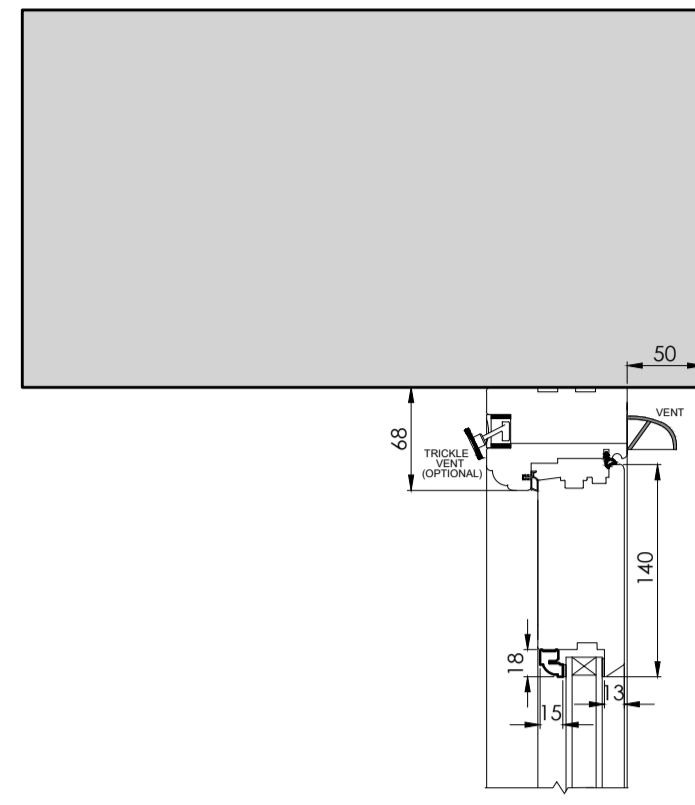
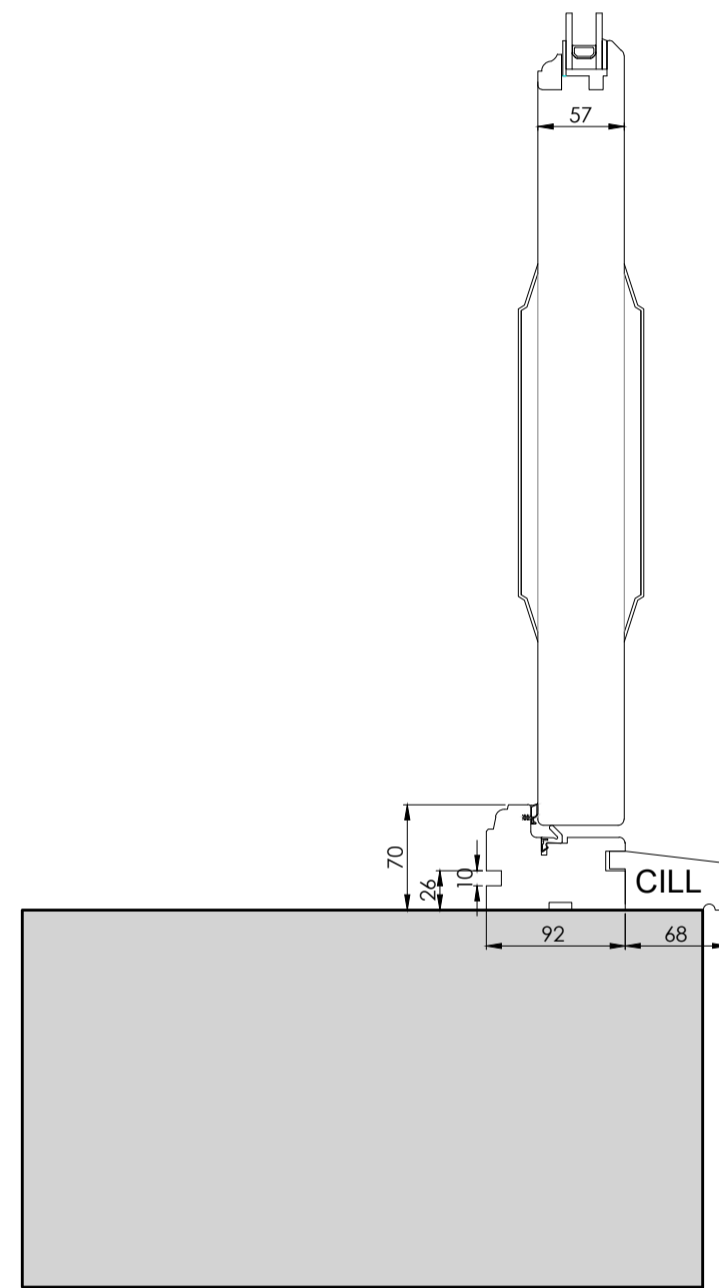

Section B - B 1:5
0 50mm 100mm 150mm 200mm 250mm 300mm 1:5

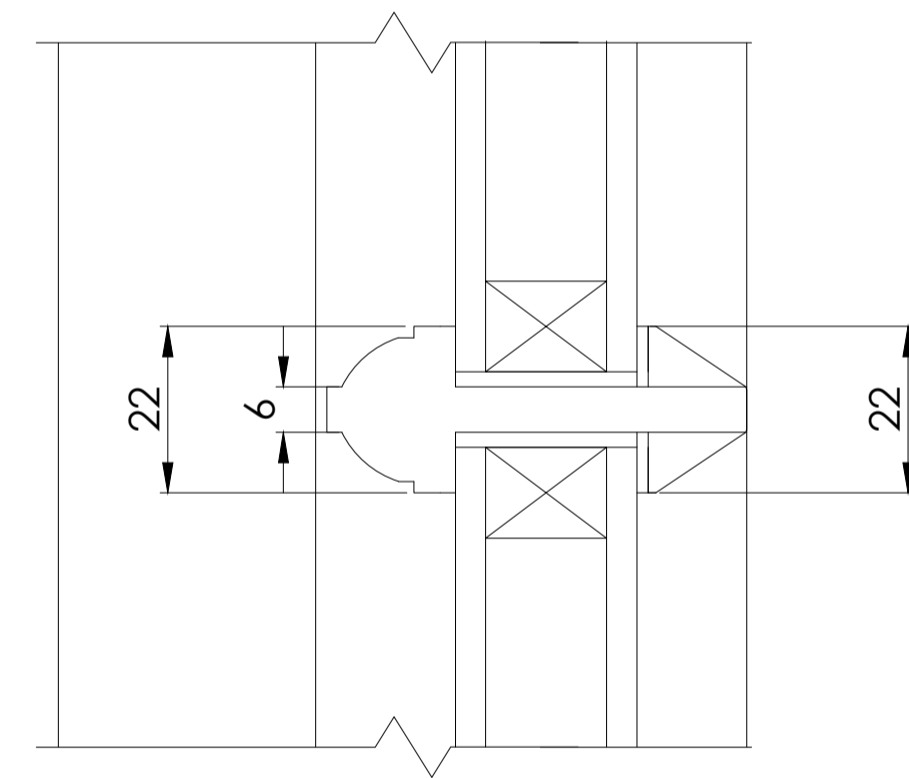

Glazing Bars 1:1
0 10mm 20mm 30mm 40mm 50mm 1:1

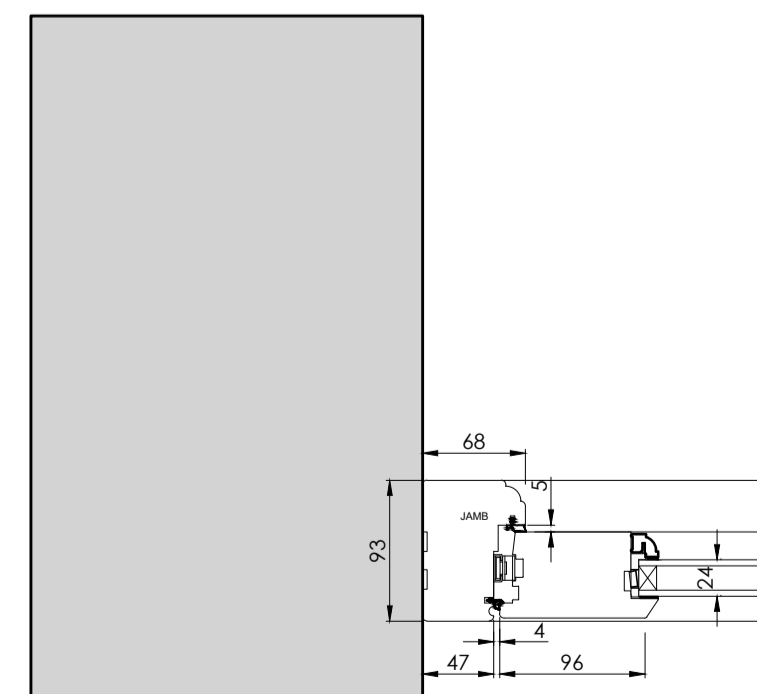

Section A -A 1:5
0 50mm 100mm 150mm 200mm 250mm 300mm 1:5

ND-04

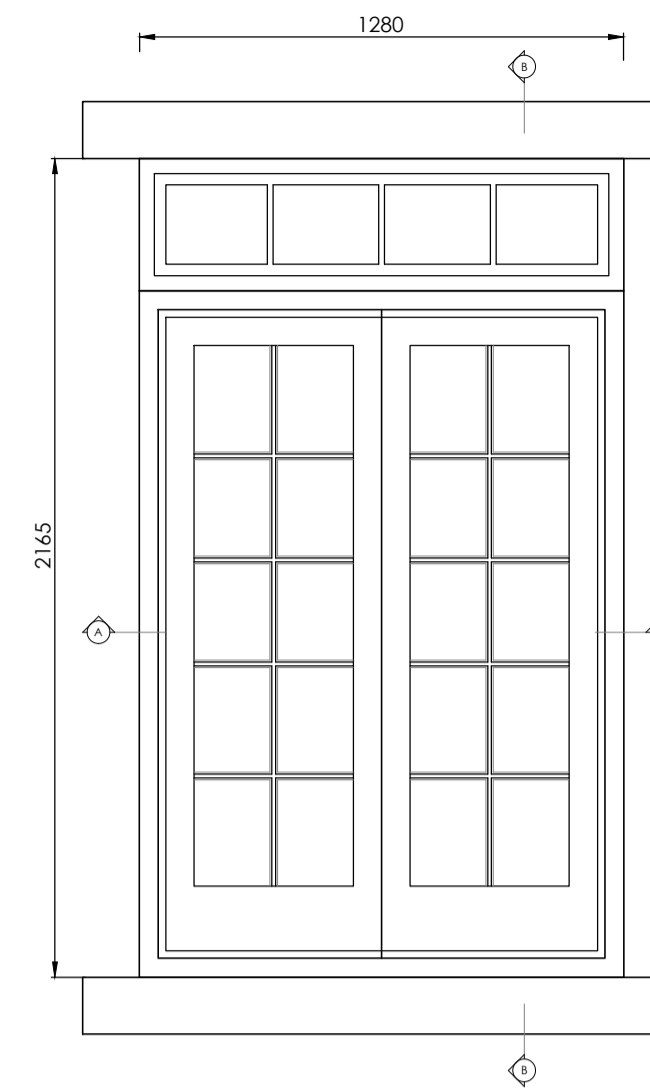
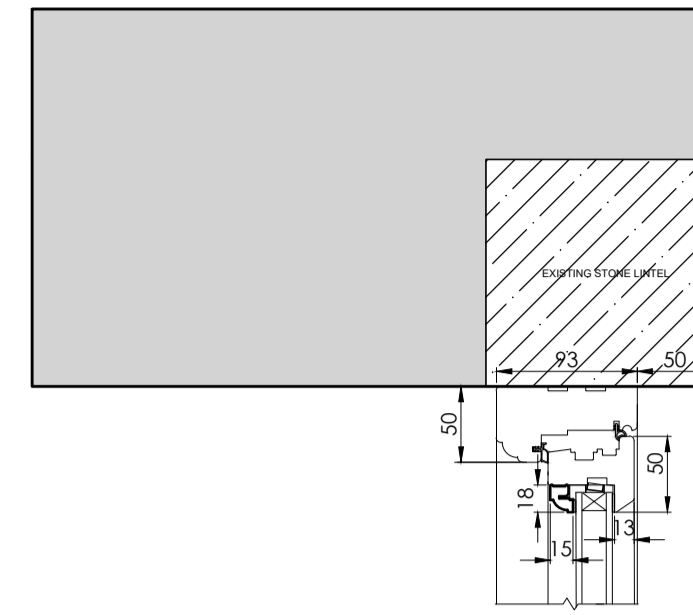

ND-04 - Ground Floor External Door - Double Glazed, Timber Frame by Westbury Windows and joinery.

Elevation 1:20
0 250mm 500mm 750mm 1m 1:20

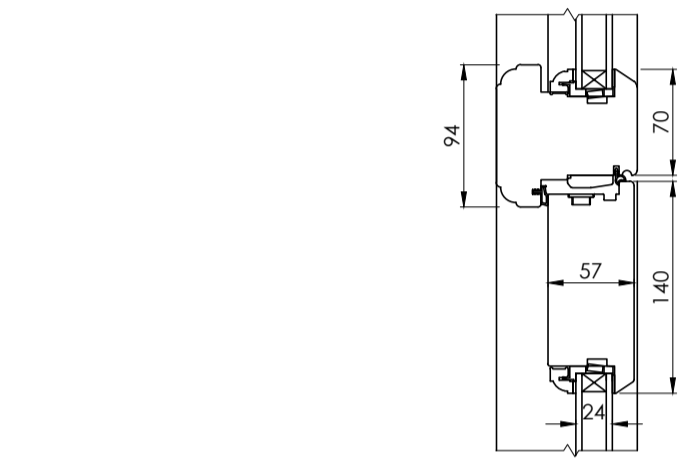

Section B - B 1:5
0 50mm 100mm 150mm 200mm 250mm 300mm 1:5

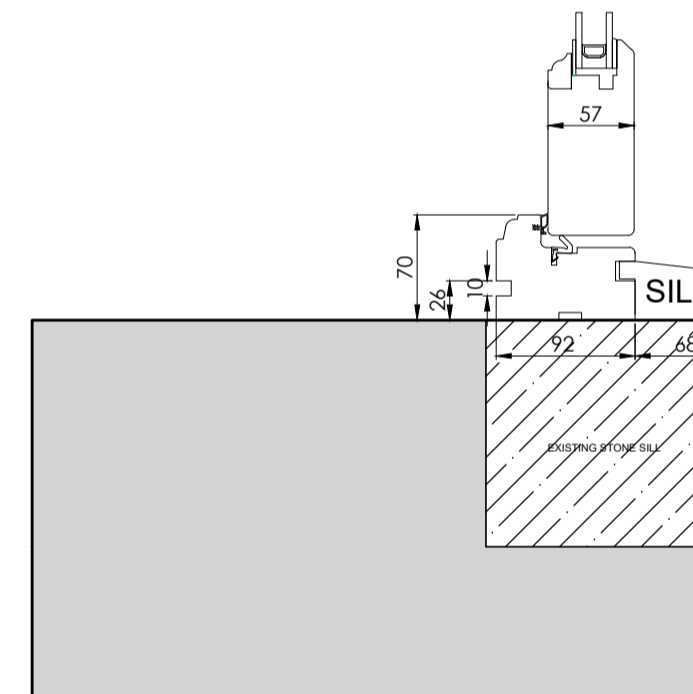

Glazing Bars 1:1
0 10mm 20mm 30mm 40mm 50mm 1:1

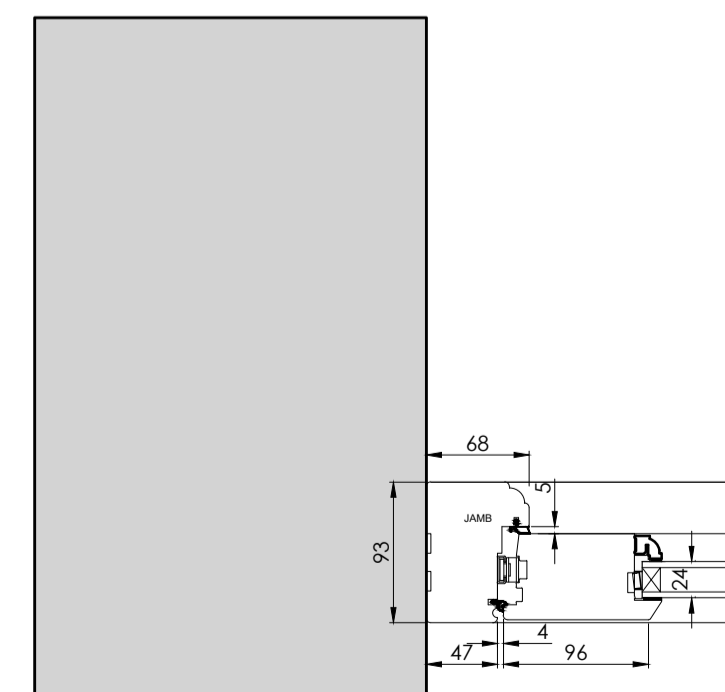

Section A -A 1:5
0 50mm 100mm 150mm 200mm 250mm 300mm 1:5

Printed or electronic copies of this drawing can be scaled for planning purposes only. Any discrepancies with this drawing to be reported and clarified prior to commencing work on site, if in doubt - Ask.
Corporate Architecture Ltd accept no responsibility for works not undertaken fully in accordance with this drawing and relevant specifications.
Copyright © Corporate Architecture Limited

Notes:

Notes:

EXTERNAL WINDOWS AND DOORS

Contractor/Manufacturer to measure site dimensions for production prior to final fabrication.

The contractor shall check the opening sizes against the size of the new window or doors to ensure that any removed can be replaced without delay.

Frames are to be fitted and fixed in accordance with the manufacturer's instructions by drilling and fixing through the outer frame into suitable surrounds with the appropriate fixings.

All windows shall be internally beaded, glazing must be in accordance with Approved Document K, BS EN 12600:2002 and BS 6206:1981, in summary this will mean all glazing in doors and door side panels within 300mm of doors between finished floor and 1500mm above, Internal and External walls and partitions between finished floor and 800mm above, alternatively in Internal and External walls and partitions between finished floor and 800mm above a permanent barrier shall be provided which prevents a 75mm dia sphere, is generally of a robust construction (in accordance with Approved Document K) and is difficult to climb.

The lifespan of the proposed system must be 60 years with regular maintenance. The window system must meet the air permeability requirements of test pressure class 600PA given in BS 6375 part 1:2009, and no deformation or damage must be recorded at an applied wind pressure of 2400PA. The window system must meet the weather tightness requirements of test pressure class 300 given in BS 6375 part 1:2009, and the window system must be tested to meet the requirements of BS6375-2:2009 and BS EN 12046-1:2003.

Rev:	Description:	By:	Date:
PD	Planning Issue	PG	24/11/23

Project:
No 4 The Green
Lyddington
Oakham
LE15 9LW

Client:
Mr & Mrs Morgan Jones

Scale:
VARIOUS

Drawn by:	Checked:	Date:	Paper Size:
PG		Nov '23	A1

Drawing Title:
Door Details - 2/2

Drawing Status:
PLANNING ISSUE

Drawing Number:	Revision Number:
5211/MJ/22/024	P0



CORPORATE ARCHITECTURE LIMITED
CHARTERED ARCHITECTS

HEAD OFFICE
Venari House, 1 Imburgh Way,
Market Harborough,
Leicestershire, LE16 7XY
Tel: 01858 467476

ISO 9001 office@corporatearchitecture.co.uk RIBA Chartered Practice
www.corporatearchitecture.co.uk