

BRISTOL GARDENS



Users\sophie\ryktors\vonhekkel\Dropbox\STUDIO HEKKEL LTD\JOB_LIST\SH PROJECTS_2023\2318_MANSHEED_20 BRISTOL GARDENS_BRIGHTON\2318_CAD\2318_20 BRISTOL GARDENS_PLANNING.pln

Do not scale from this drawing for the purpose of construction. Work to indicated dimensions only. All dimensions to be confirmed on site. This drawing is to be read in conjunction with other drawings in this series and all relevant consultants drawings and documentation where applicable. This drawing has been produced for the specific client and project identified below and is not intended for use by any other person or for any other purpose other than indicated on this drawing. Please report any discrepancy on this drawing to studio HEKKEL for clarification. © studio HEKKEL Ltd

0 1m 3m
1:50 scale

NO. 18
DOUBLE GARAGE

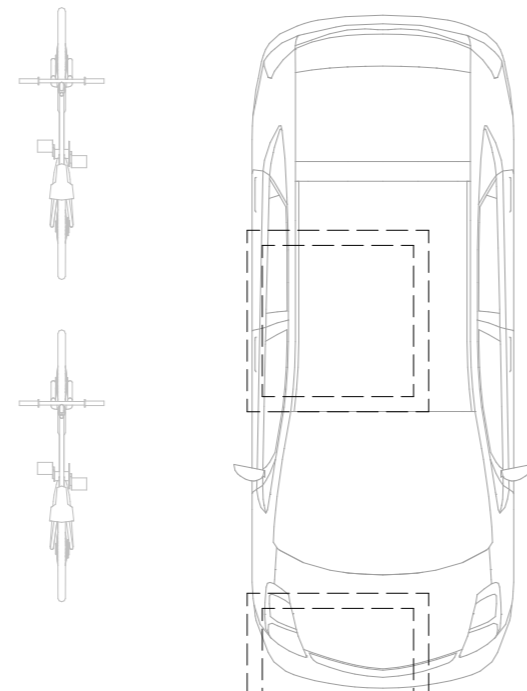

69.992 m²

**OFFICE /
STUDY AREA**

**GARAGE
WORKSHOP**



WORK BENCH

STEP UP

WC

PEDESTRIAN ACCESS PATH

NO. 22A

TWO STOREY RESIDENTIAL
DWELLING WITH PITCHED ROOF

23 SUSSEX SQUARE
GROUND FLOOR FLAT
COURTYARD GARDEN

SERVICES CUP'D

24 SUSSEX SQ
GF FLAT
COURTYARD

22A WALLED GARDEN



studioHEKKEL
hello@studiohekkel.com | www.studiohekkel.com

Client

M. BARNES

Project

ADDITIONAL STOREY, 20 BRISTOL GARDENS, BRIGHTON

Drawing Title

EXISTING FLOOR PLAN

Status

PLANNING

Date of Issue

17/11/2023

Scale

1:50 @ A3

PROJECT - STAGE - DRAWING - REVISION

2318-P-003