

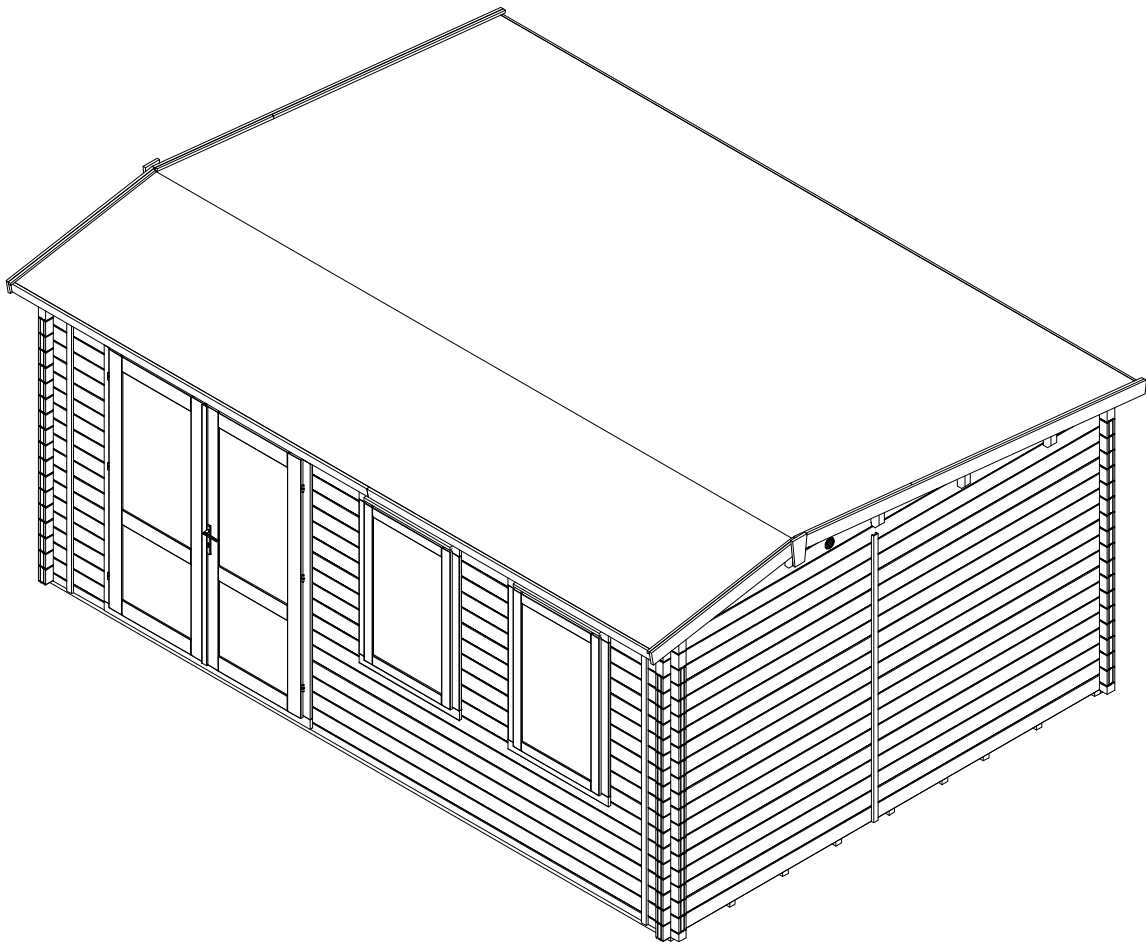

MODETRO WARMALOG CABIN 5.4m x 3.8m LOG CABIN

INSTALLATION MANUAL



Important!

All dimensions are approximate and subject to the limitations of the materials used and the methods of manufacture

Unique Cabin Reference Number

www.dunsterhouse.co.uk

Warmalog MODETRO 5.4m x 3.8m Log Cabin Components

BEARER
 WL-B-300 **x12**
 WL-B-5250 **x11**
 Pressure Treated

BOTTOM LOG
 WL-BL-5390-DN **x2**

INSULATED WALL LOG
 WL-IWL-465 **x22**

INSULATED WALL LOG
 WL-IWL-600-SN **x28**
 WL-IWL-3110-SN **x6**

INSULATED WALL LOG
 WL-IWL-3800-DN **x34**
 WL-IWL-5390-DN **x17**

SOLID WALL LOG
 WL-SWL-5390-DN **x1**

PURLIN LOG
 WL-PL-5390-DN-6 **x1**

PURLIN LOG
 WL-PL-5390-DN-10 **x1**

INTERMEDIATE PURLIN SUPPORT
 WL-IPAS-5390-6 **x3**

APEX PURLIN SUPPORT
 WL-APS-5390 **x1**

FASCIA BOARD
 WL-FB-2950-6 **x2**

FASCIA BOARD
 WL-FB-1250-10 **x2**

EAVE FASCIA
 WL-EF-3000 **x4**

ROOF BOARD
 WL-RB-1200 **x60**
 WL-RB-2900 **x60**

COVER MOULD
 WL-CM-2200 **x14**

TRIM
 WL-T-1960 **x16**

Warmalog MODETRO 5.4m x 3.8m Log Cabin Components

ROOF PANEL A

WL-RP-40x500x2400.A **x2**
 WL-RP-40x590x2400.A **x1**
 WL-RP-40x1200x2400.A **x2**

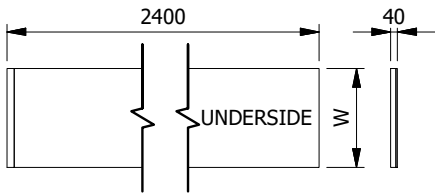

ROOF PANEL A

WL-RP-40x590x1200.A **x1**

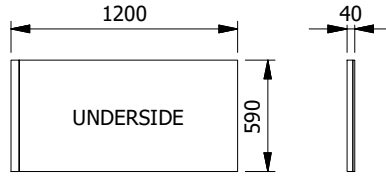

ROOF PANEL C

WL-RP-40x1200x2400.C **x2**

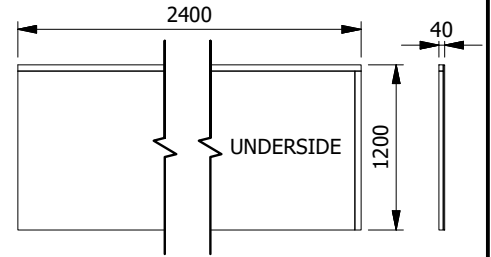

ROOF PANEL D

WL-RP-40x1200x2400.D **x2**

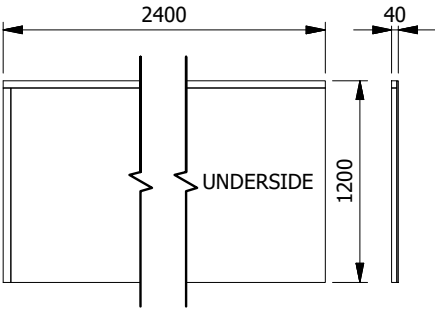

ROOF PANEL E

WL-RP-40x590x500.E **x1**

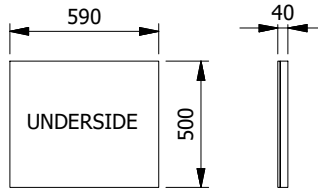

FLOOR PANEL

WL-IFP-50x760x2400 **x2**
 WL-IFP-50x1200x2400 **x3**

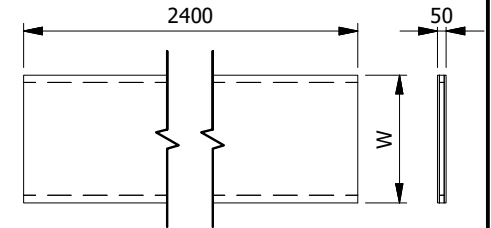

FLOOR PANEL

WL-IFP-50x1135x1700 **x1**
 WL-IFP-50x1135x1710 **x2**

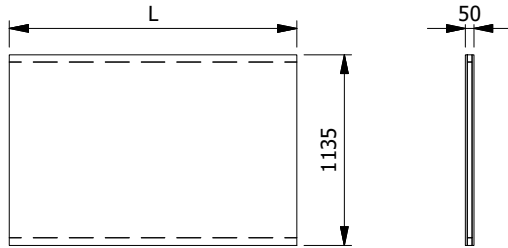

TRAPEZOID FINIAL

WL-TF-195 **x2**

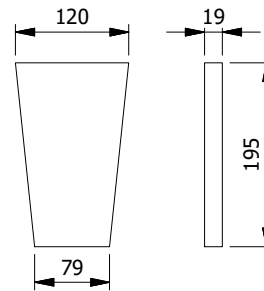

KNOCK DOWN BLOCK

x4

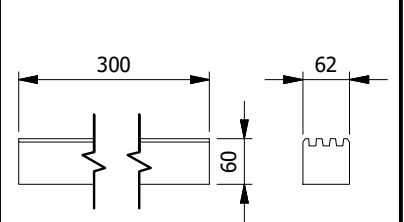

SHOOT BOLT PACKING PIECE (WPC)

DHWLSBPP **x2**

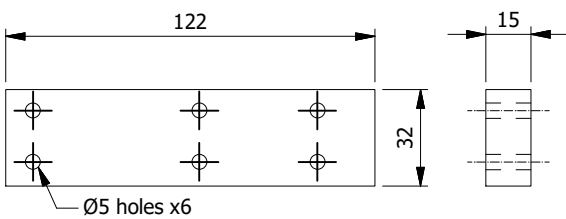

STEEL BRACE

WL-SB-800 **x21**
 WL-SB-2080 **x5**
 WL-SB-2140 **x2**

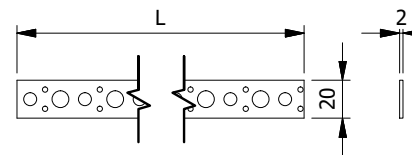

UPPER WINDOW FILLET

WL-UWF-62x35x775 **x2**

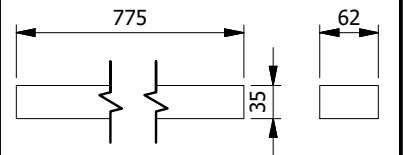

WINDOW DRIP TRAY

Drip Tray 845 **x2**

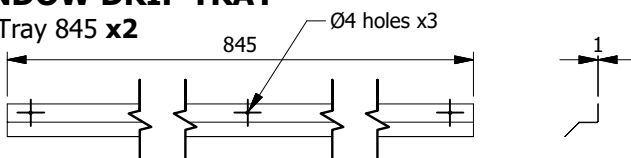

DOOR DRIP TRAY

Drip Tray 1735 **x1**

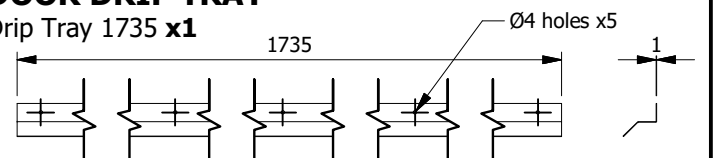

E9 - Warmalog Window (62mm)

x2

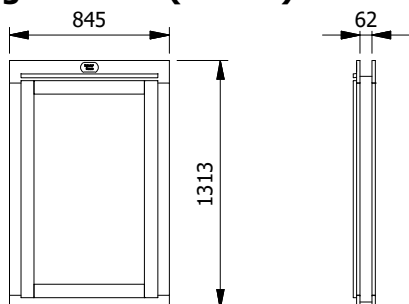

E9-Warmalog Double Door (62mm)

x1

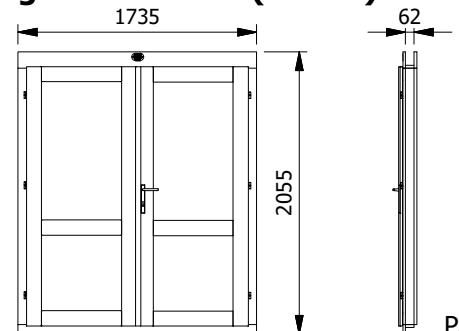

Warmalog MODETRO 5.4m x 3.8m Log Cabin Components

APEX ASSEMBLY

WL-A-3800-DN-M-6 & 10 x2

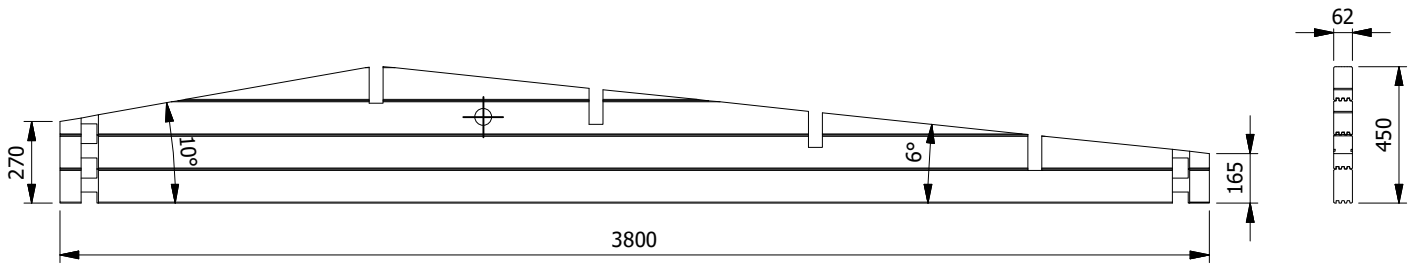

TABLE

ITEM	QTY
20mm x 4.5mm Screws for Shoot Bolt Angle Brackets	2
25mm x 2.5mm Screws for Vents	8
30mm x 4mm Screws for Drip Trays	11
35mm x 3.5mm Screws for Bearer Brackets, Roof Weather Trims, Shoot Bolt Packing Pieces, Trapezoid Finials, Eave Fascia, Steel Bracing	392
50mm x 4mm Screws for Bottom Wall Logs, Roof Panels, Fascia Boards	146
70mm x 4.5mm Screws for Bearers, Bottom Wall Logs, Purlins, Window Frames, Door Frame, Floor Panels	220
90mm x 4.5mm Screws for Wall Log Notched Corners	160
M6 x 70mm Bolts & Nuts for Steel Bracing	28
40mm Nails for Roof Boards	420
40mm x 1.6mm Panel Pins for Floor Trims, Cover Moulds	180
20mm Clout Nails for Roof Felt	1464
Roof Felt 1000mm x 5500mm	5
Roof Felt (Capping) 900mm x 5500mm	1
2mm Plastic Spacers for spacing Roof Boards	10
Door Handle Set & Accessories	1
Door Lock Cylinder	1
Door Shoot Bolt Assembly	2
Door Shoot Bolt Angle Bracket	2
Window Handle Set & Accessories	2
Pair of Vents	2
Bearer Brackets 40mm x 40mm	14

Bearer Layout for MODETRO Warmalog Cabin 5.4m x 3.8m (62mm)

Log Cabin Bearer Layout MODETRO 5.4m x 3.8m (62mm)

We suggest preparing minium overall base dimension of 5450mm x 3860mm

Fix the double bearers and
bearer ladder using 70mm screws

REAR

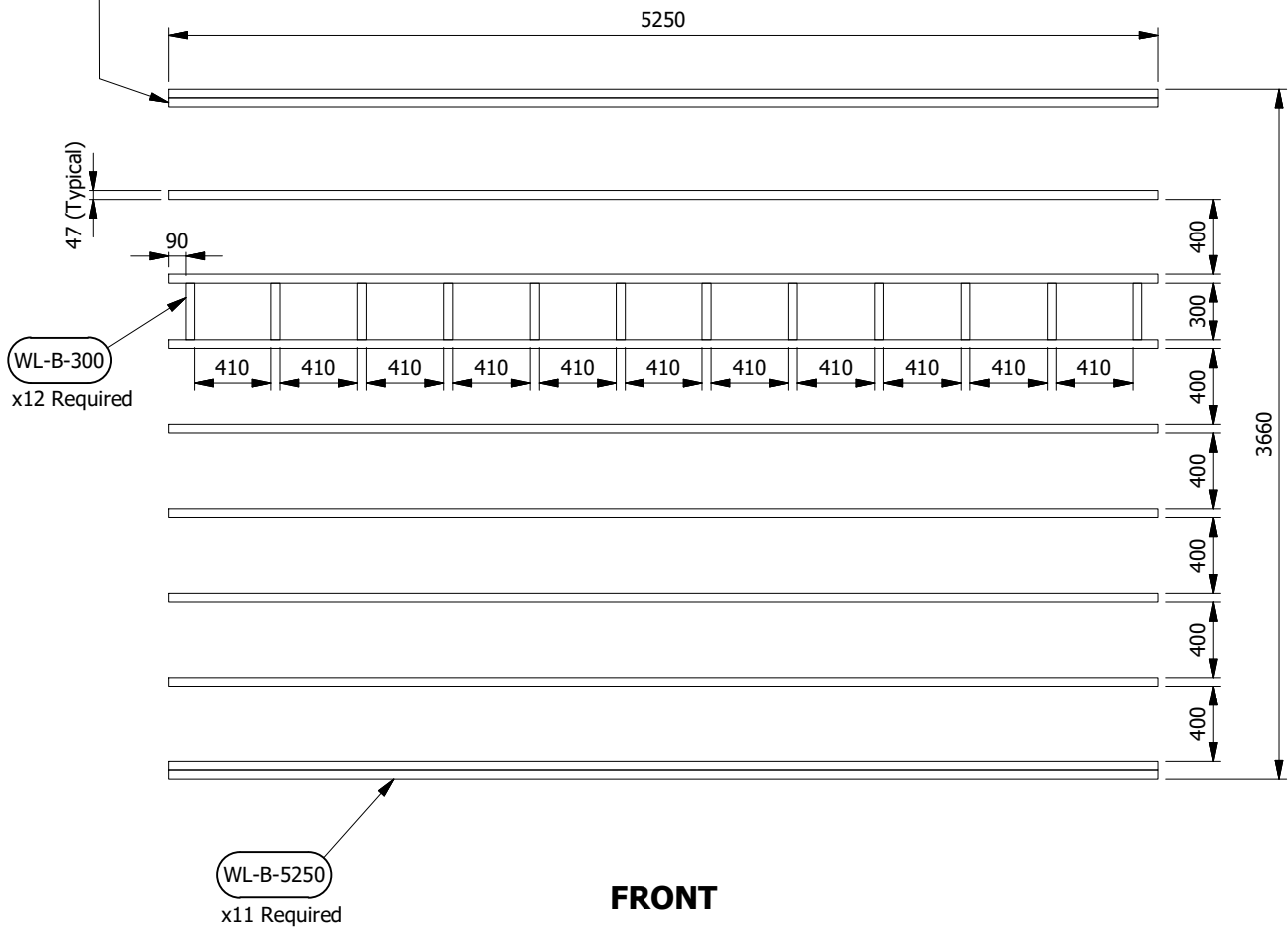

Front Wall Layout for MODETRO Warmalog Cabin 5.4m x 3.8m (62mm)

FRONT WALL

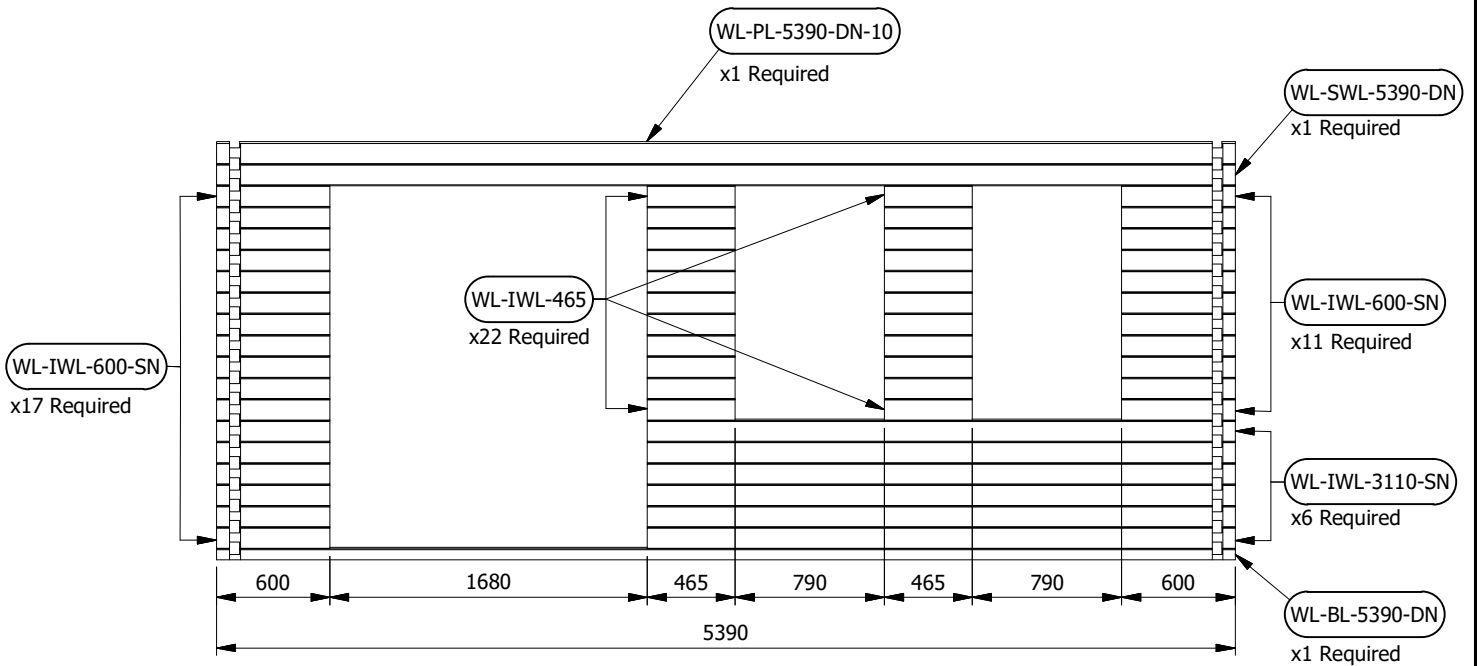

Rear Wall Layout for MODETRO Warmalog Cabin 5.4m x 3.8m (62mm)

REAR WALL

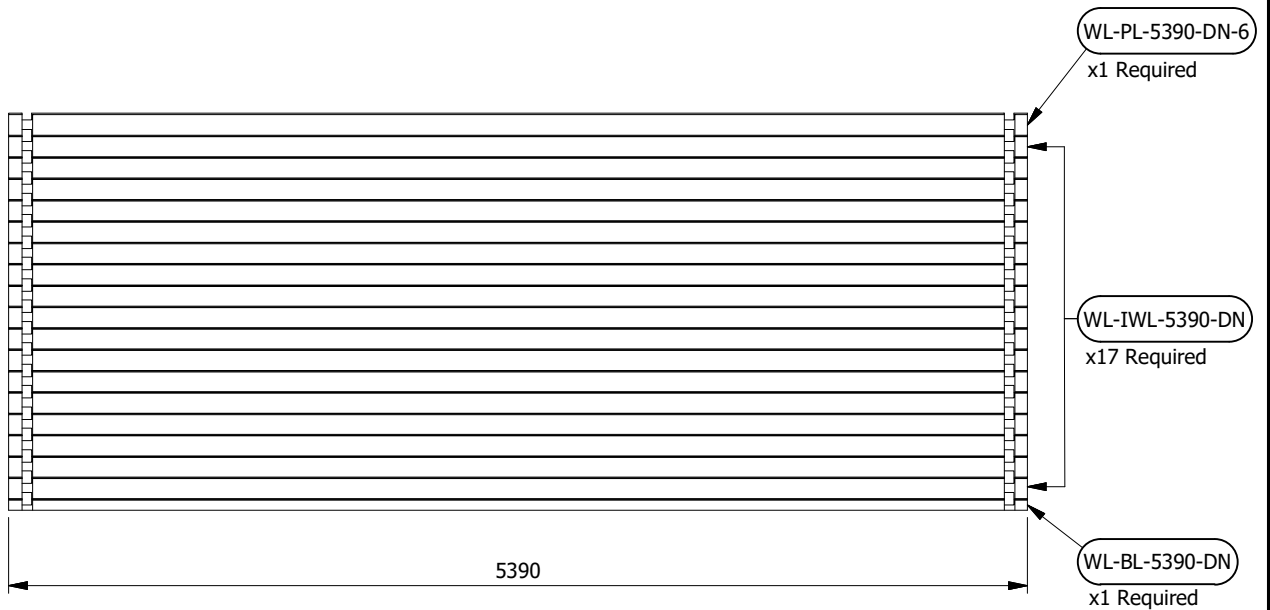

Side Wall Layout for MODETRO Warmalog Cabin 5.4m x 3.8m (62mm)

SIDE WALLS

(x2 Required)

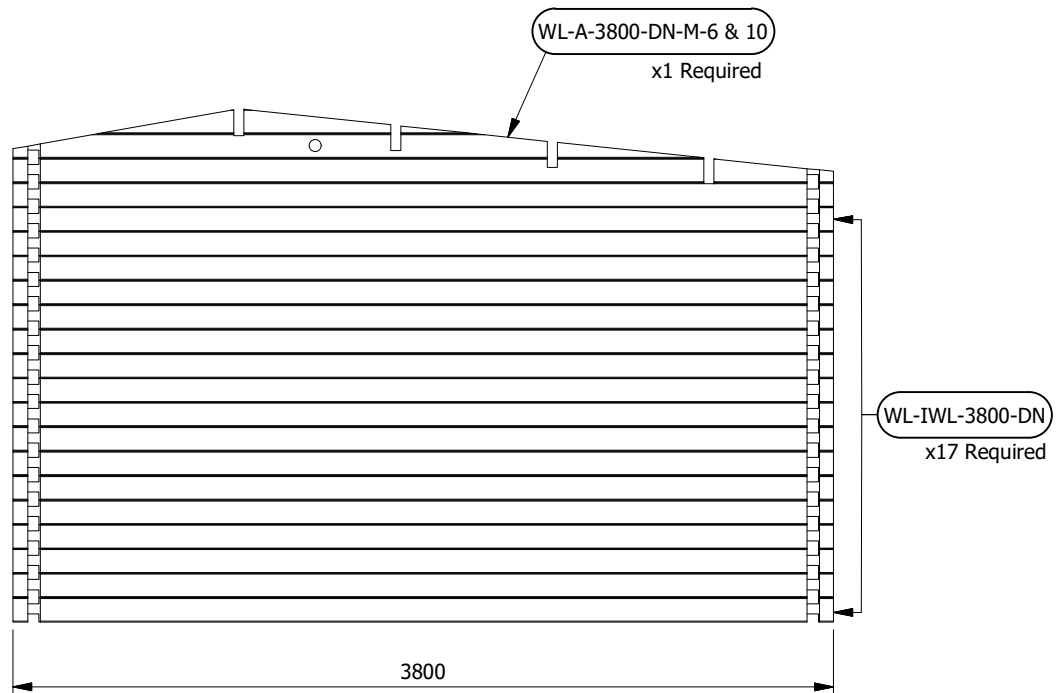

Purlin Layout for MODETRO Warmalog Cabin 5.4m x 3.8m (62mm)

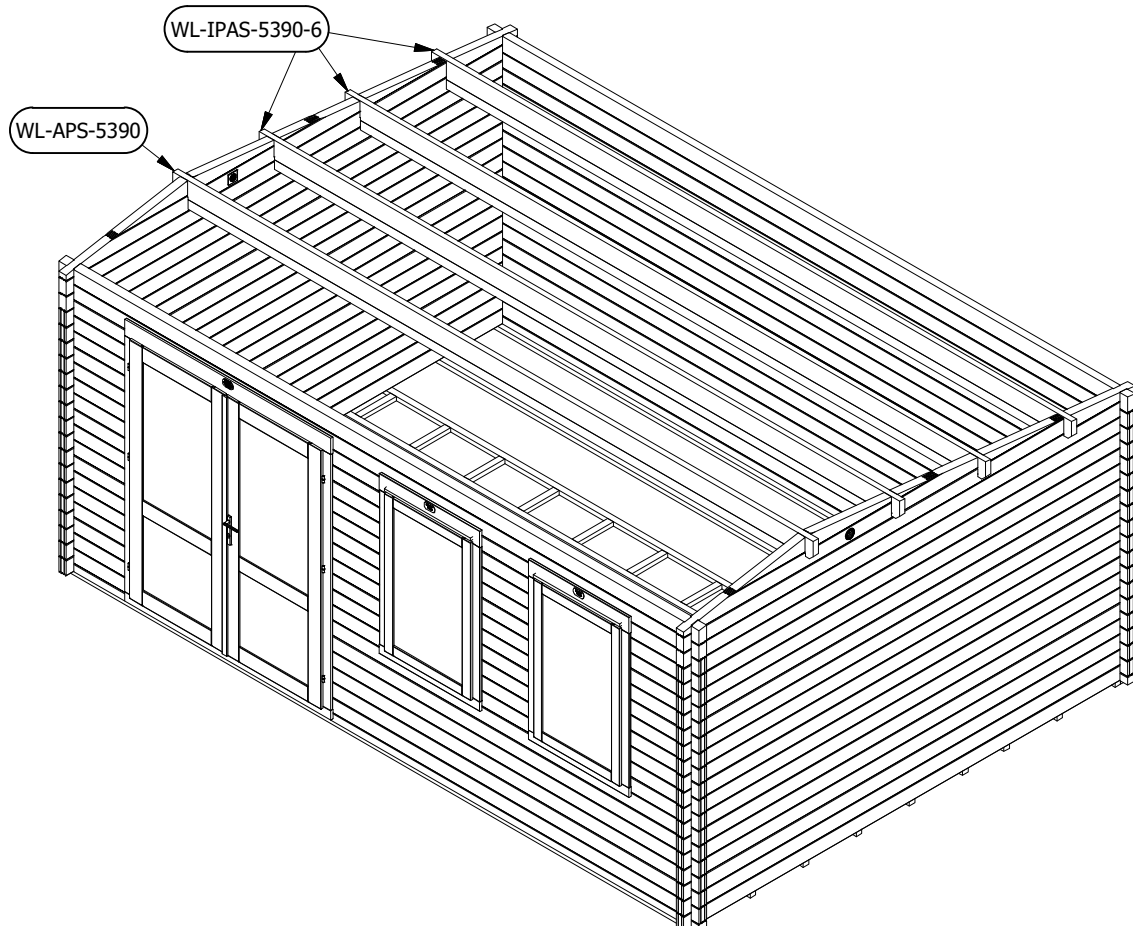

Roof Board Layout for MODETRO Warmalog Cabin 5.4m x 3.8m (62mm)

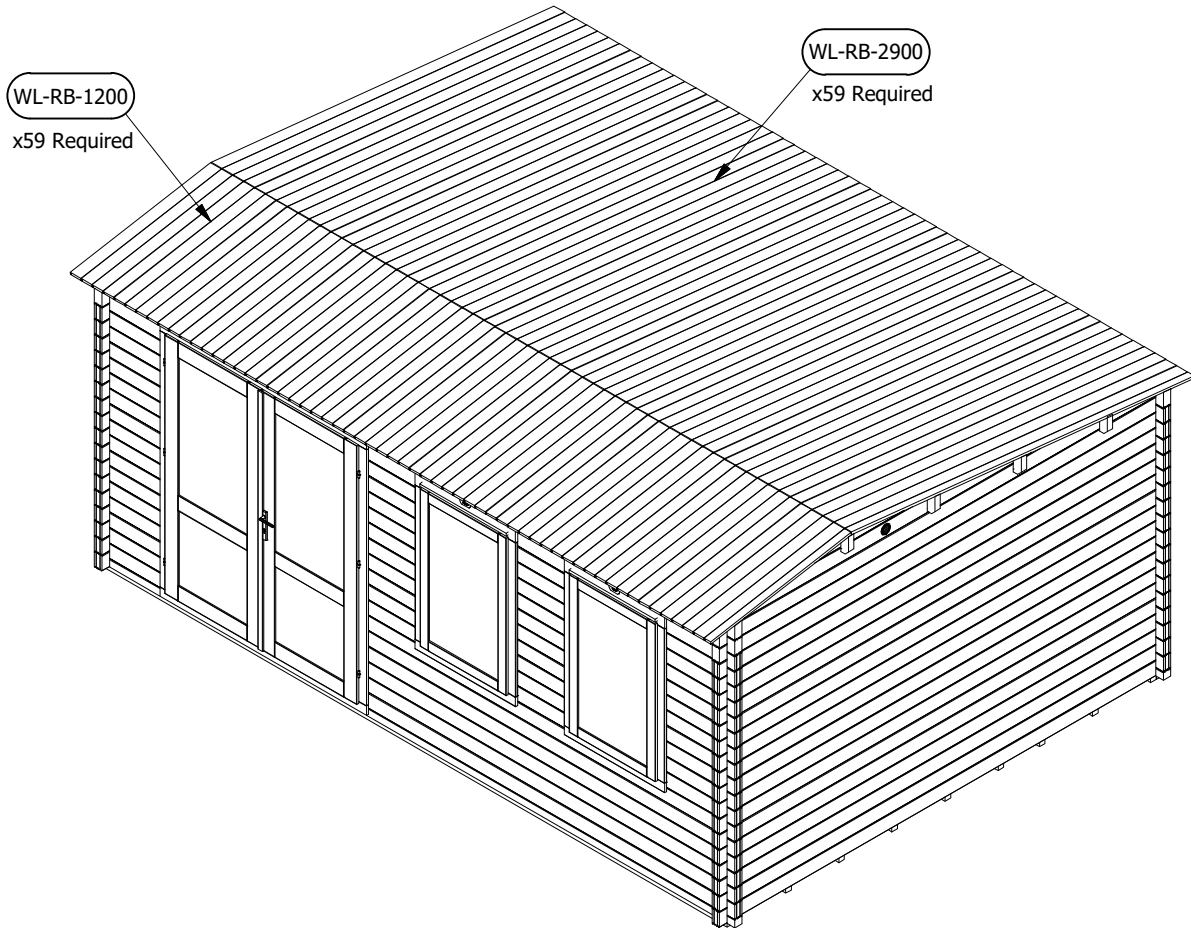

Roof Panel Layout for MODETRO Warmalog Cabin 5.4m x 3.8m (62mm)

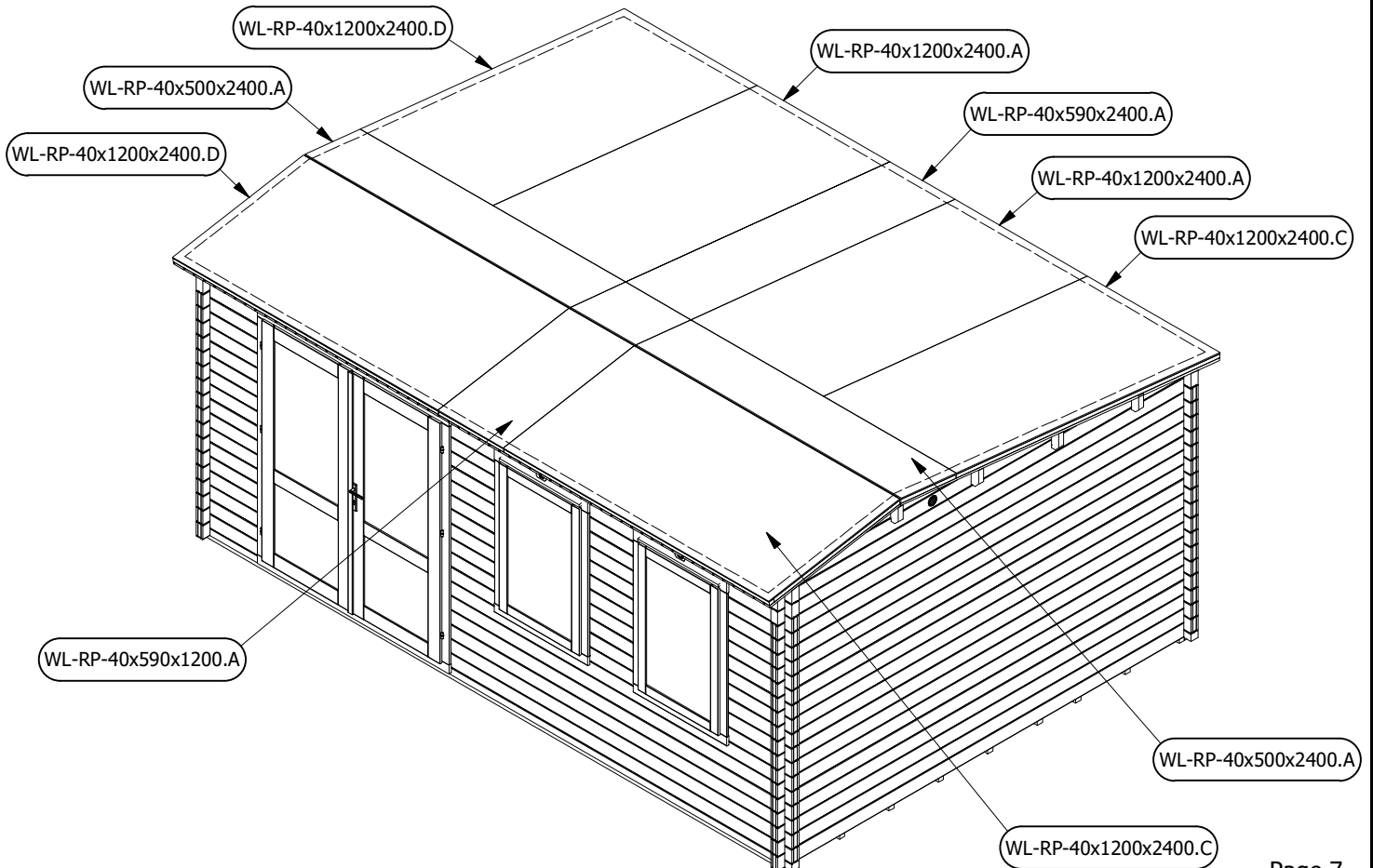

Roof Felt & Fascia Layout for MODETRO Warmalog Cabin 5.4m x 3.8m (62mm)

Roof Felt
1000mm x 5500mm strips
x5 required

Roof Felt Capping Piece
900mm x 9000mm strip
x1 required

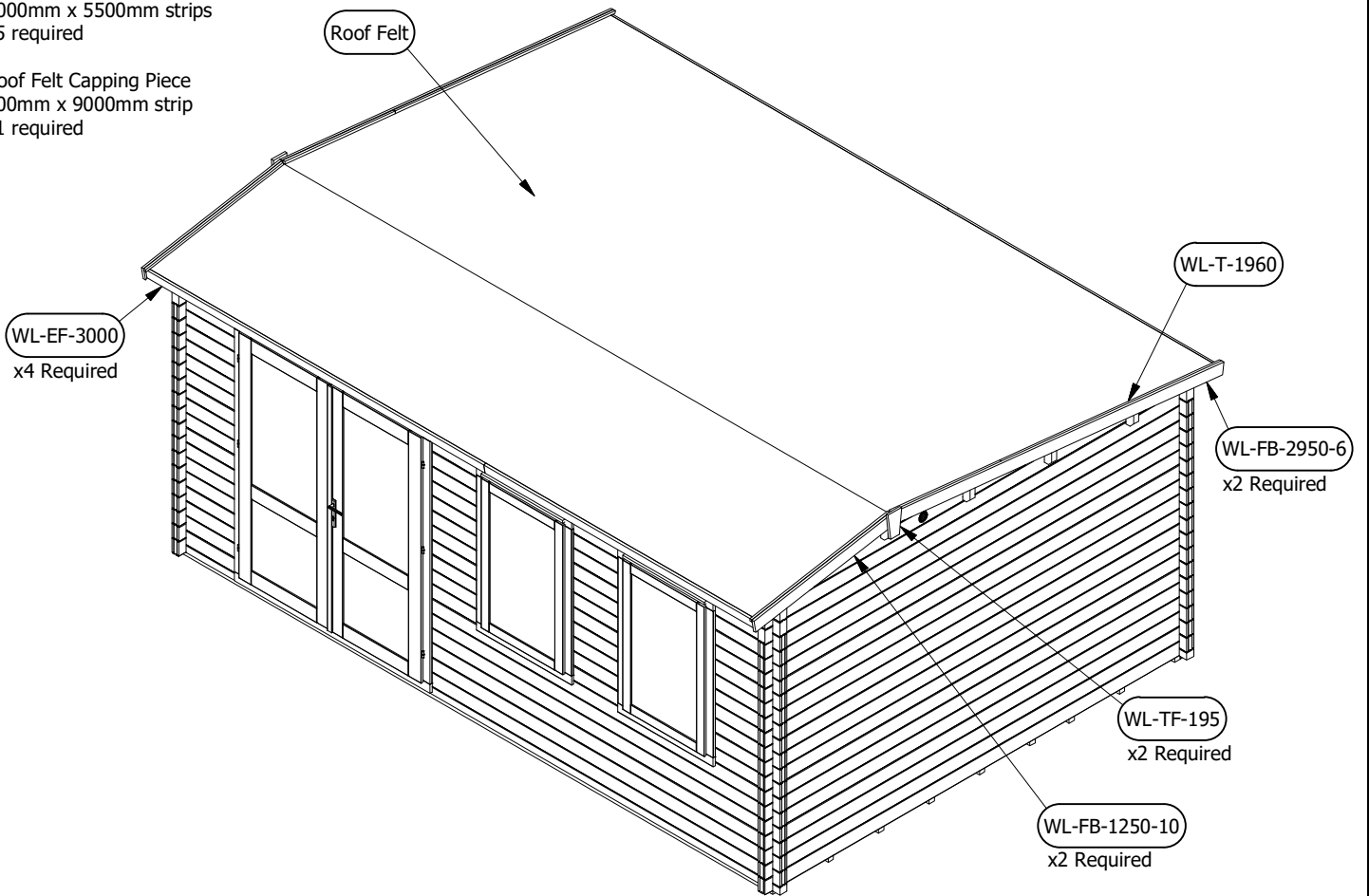

Floor Panel Layout for MODETRO Warmalog Cabin 5.4m x 3.8m (62mm)

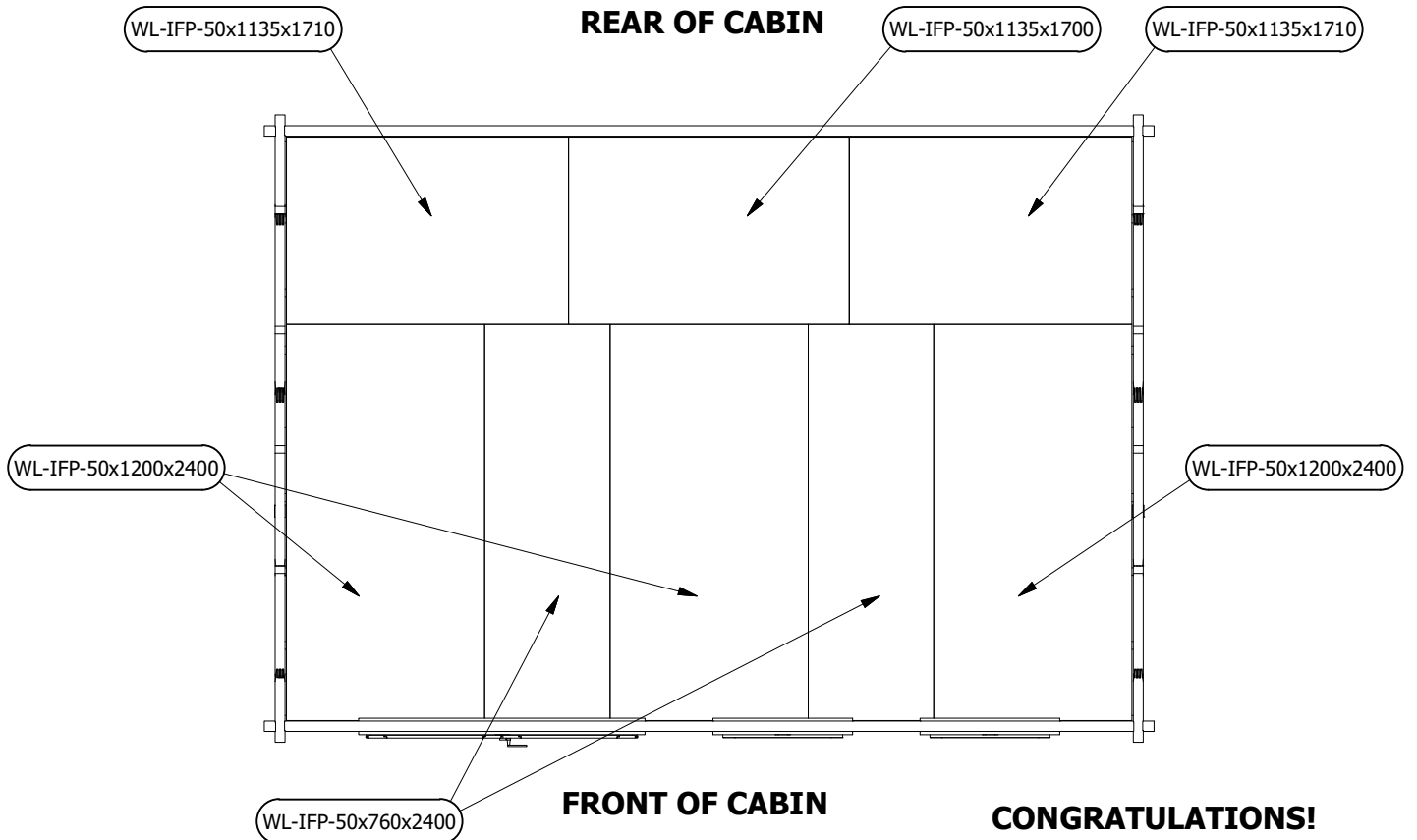

**CONGRATULATIONS!
YOUR CABIN IS NOW COMPLETE**