

TWINPLUS MODULE SERIES

HIGH EFFICIENCY MONO-PERC M6-10B-R

535-555W



OUTSTANDING PRODUCT PERFORMANCE

- Competitive high-temperature performance with ameliorated temperature coefficient
- Minimized power loss in cell connection
- Better performance under shading effect
- Decreased nominal operating cell temperature to $45 \pm 2^{\circ}\text{C}$
- Higher power generation with multi-busbar and half-cut technology

TRUSTWORTHY QUALITY AND RELIABILITY

- Guaranteed 0~+5W positive tolerance secures reliable power output
- 5400Pa maximum snow load, 2400Pa maximum wind load
- Optimized electrical design lowers hot spot risk and operating current

PID RESISTANT

- Industry-leading cell processing technology and electrical design ensure solid PID resistance

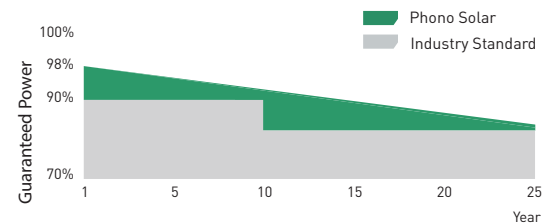

12-year Product Warranty

25-year Linear Performance Warranty

MANAGEMENT SYSTEM CERTIFICATES

IEC 61215, IEC 61730

ISO 9001:2015 / Quality management system

ISO 14001:2015 / Standards for environmental management system

ISO 45001:2018 / International standards for occupational health & safety



Bloomberg Tier¹
NEW ENERGY FINANCE



ELECTRICAL TYPICAL VALUES

Model	1000V	PS535M6-24/TH		PS540M6-24/TH		PS545M6-24/TH		PS550M6-24/TH		PS555M6-24/TH	
	1500V	PS535M6H-24/TH		PS540M6H-24/TH		PS545M6H-24/TH		PS550M6H-24/TH		PS555M6H-24/TH	
Testing Condition		STC	NOCT	STC	NOCT	STC	NOCT	STC	NOCT	STC	NOCT
Rated Power (Pmpp)		535	398	540	402	545	405	550	409	555	413
Rated Current (Impp)		12.97	10.48	13.06	10.55	13.15	10.63	13.24	10.70	13.55	10.77
Rated Voltage (Vmpp)		41.25	37.98	41.35	38.07	41.45	38.16	41.55	38.25	41.64	38.34
Short Circuit Current (Isc)		13.52	10.92	13.62	11.00	13.72	11.09	13.82	11.17	13.92	11.25
Open Circuit Voltage (Voc)		49.29	46.53	49.39	46.62	49.49	46.72	49.59	46.81	49.69	46.91
Module Efficiency (%)		20.71		20.90		21.10		21.29		21.48	

STC(Standard Testing Conditions):Irradiance 1000W/m², AM 1.5, Cell Temperature 25°C

NOCT (Nominal Operation Cell Temperature): Irradiance 800W/m², Ambient Temperature 20°C, Spectra at AM1.5, Wind at 1m/S

MECHANICAL CHARACTERISTICS

Cell Type	Monocrystalline 182mm x 91mm
Dimension (L×W×H)	Length: 2278mm (89.69 inch)
	Width: 1134mm (44.65 inch)
	Height: 35mm (1.38 inch)
Weight	29.0kg (63.93 lbs)
Front Glass	3.2mm Toughened Glass
Frame	Anodized Aluminium Alloy
Cable (Including Connector)	4mm ² (IEC), (+):450mm,(-):250mm or Customized Length
Junction Box	IP 68 Rated

TEMPERATURE RATINGS

Voltage Temperature Coefficient	-0.28%/°C
Current Temperature Coefficient	+0.05%/°C
Power Temperature Coefficient	-0.35%/°C
Tolerance	0~+5w
NOCT	45±2°C

ABSOLUTE MAXIMUM RATING

Operating Temperature	From -40 to +85°C
Hail Diameter @ 80km/h	Up to 25mm
Front Side Maximum Static Loading	5400Pa
Rear Side Maximum Static Loading	2400Pa
Maximum Series Fuse Rating	25A
PV Module Classification	II
Fire Rating (IEC 61730)	C
Maximum System Voltage	DC 1000V/1500V

PACKING CONFIGURATION

Container	20' GP	40' HQ
Pieces/Container	155	620

ELECTRICAL CHARACTERISTICS

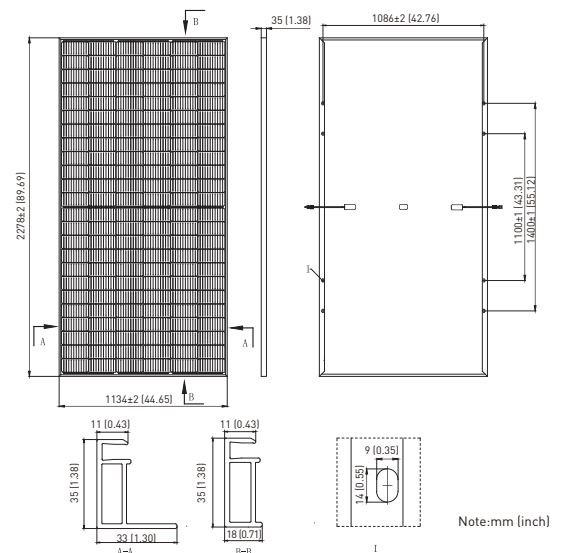
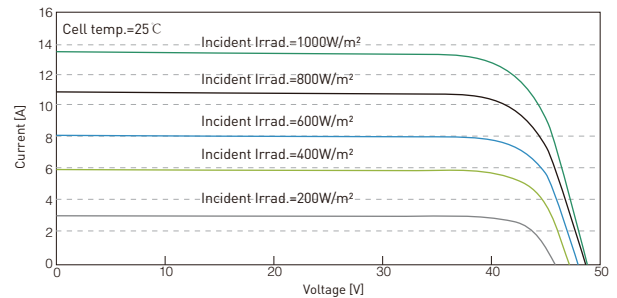
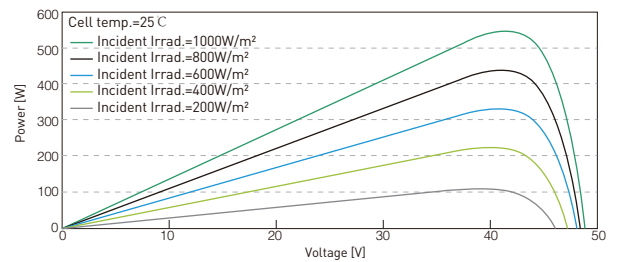

System Datasheet

CS+

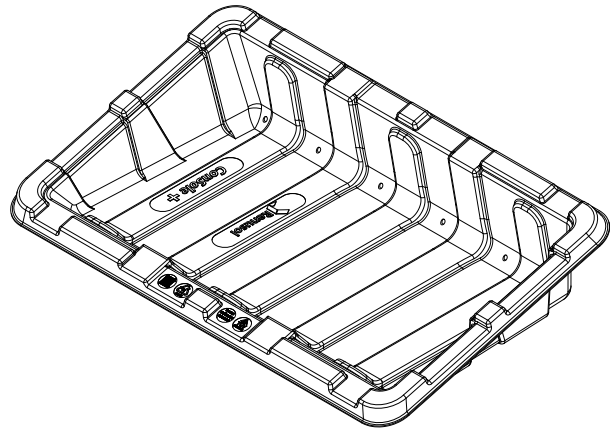

General

System	Freestanding ballasted PV mounting system
Scope of delivery	CS+ tub, mounting profiles and fixing material
System warranty	10 years
Application area	Flat roofs, landfills, open spaces, green areas (excluding hydrogen sulphide exposure)
Dimensions	Width: 1.730mm, depth: 1.100 mm, height: 390mm
Roof slope	max. 5° without additional measures
Ambient temperature range	-30°C to +50°C

System properties

System orientation	East-West, South
Material	HDPE, aluminium and stainless steel
Module tilt	15°
System weight approx.	≈ 7,9 kg
Friction coefficient	$\mu = 0,5$ is to be determined and ensured upon installation surface.
Minimum edge distance	1,5 m
Maximum snow load on the roof	2,5 kN/m ²

Certifications

TÜV	ID1111212485 according to 2PFG
Wind loads	Determined in wind tunnel tests by Ruscheweyh Consult GmbH
Fire resistance	MPA Dresden
UV resistance	KIMW Kunststoff Institut Lüdenscheid

Services

PV layout	Provided by Renusol
Ballast plan	Provided by Renusol

System Datasheet

CS+

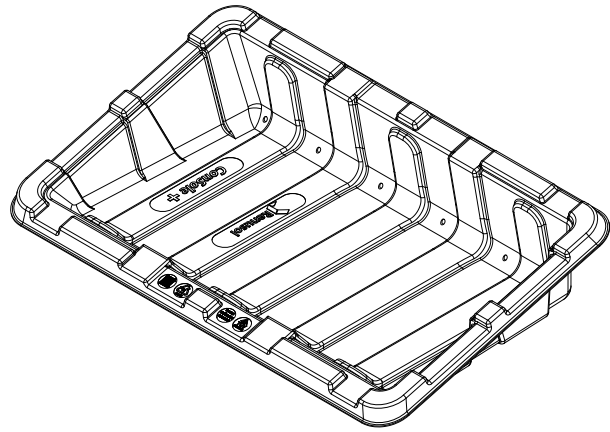

Modules

Type	Framed PV modules with mounting hole
Module length	1550 mm - 2400 mm
Module guidance	Horizontal/landscape format

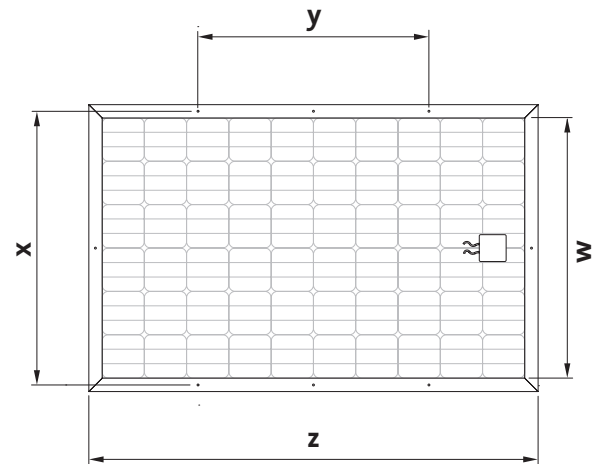
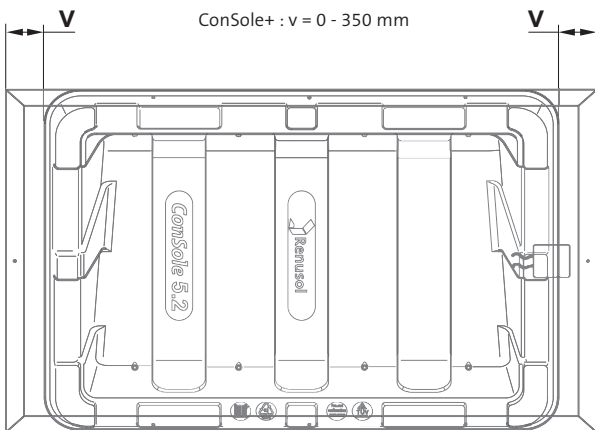

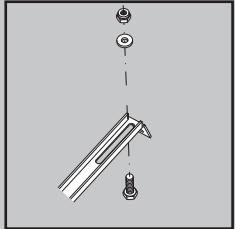
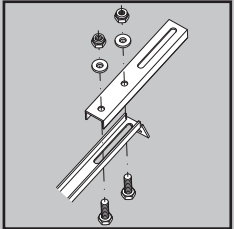
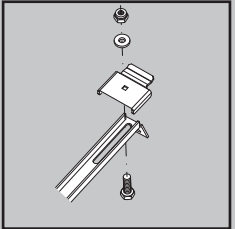
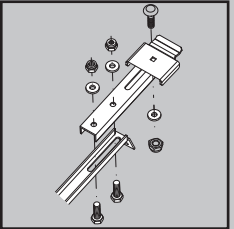
				
Article No.	R520075-K	R520075-K + R460001	R520075-K + R420023	R520075-K + R460001 + R420023
Modul min. w:	-	-	933 mm	996 mm
Modul max. w:	-	-	995 mm	1075 mm
Modul min. x:	895 mm	1016 mm	-	-
Modul max. x:	1015 mm	1085 mm	-	-
Modul min. y:	690 mm	690 mm	-	-
Modul max. y:	1180 mm	1180 mm	-	-
Modul min. z:	1550 mm	1550 mm	1550 mm	1550 mm
Modul max. z:	2400 mm	2400 mm	2400 mm	2400 mm



GSE GROUND SYSTEM™ V3.0

Ground-mounted system for framed photovoltaic modules

FUNCTIONAL, AESTHETIC, QUICK TO INSTALL,
SIMPLE...

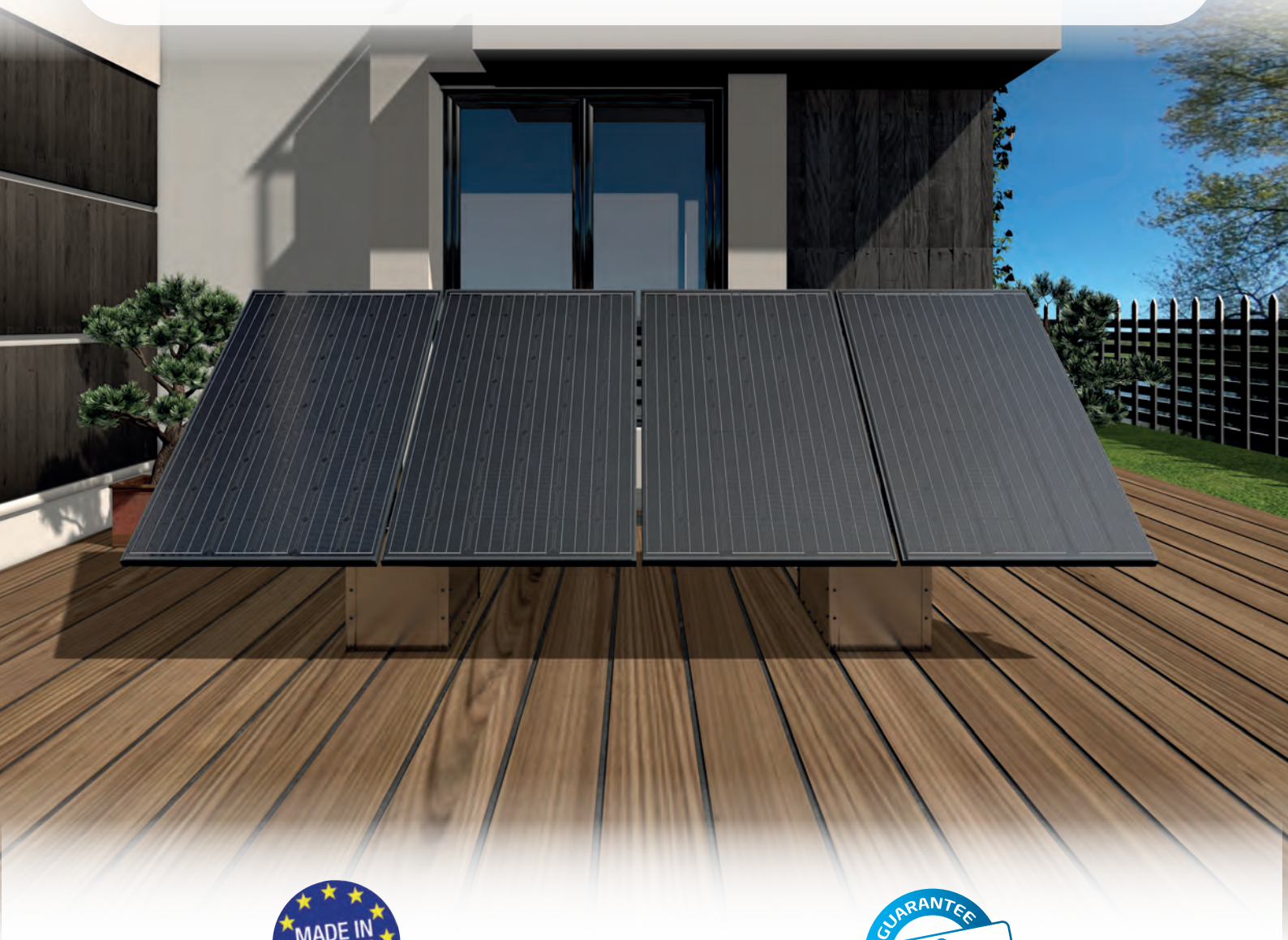

CHUBB®



www.gseintegration.com



ADVANTAGES



EASY TO INSTALL
No drilling or specific masonry



COMPATIBLE WITH ALL MODULE SIZE



NO PAPERWORK NEEDED



RESOLVES ROOF SPACE PROBLEMS
Portrait installation for reduced dimensions



COMPATIBLE WITH ALL TYPE OF GROUND
No problem with grass height

TECHNICAL SPECIFICATIONS

CONFIGURATION	Portrait installation in multiples of 2 modules
INCLINATION	Adjustable inclination from 7° to 40°
MATERIAL	Galvanized steel
WEIGHT WITHOUT BALLAST	8kg / module
BALLAST SYSTEM	Sand, gravel, cement, concrete slabs ...
SAFETY	Possibility to use microinverters: very low voltage operation for safe wiring
BAR / RAIL SIZE AVAILABLE	2320mm wide steel Z-bar for module 2.40 and 3.58m aluminum rails

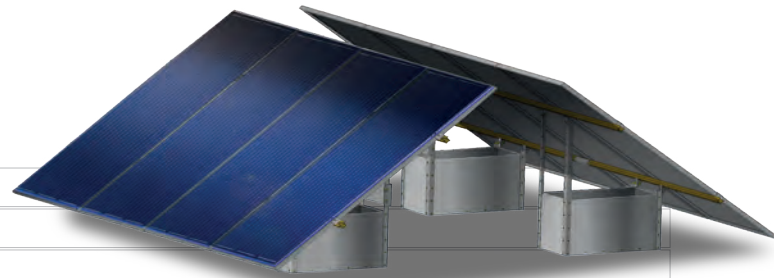

TWO MOUNTING METHODS

BOLTING ON «Z» BAR
Fixing of the modules by bolting

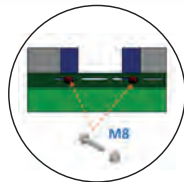
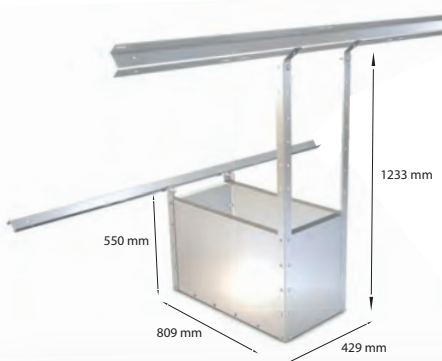

TRADITIONAL MOUNTING ON ALUMINUM RAIL (ON-ROOF RAIL)
Fixing of the modules using clamps

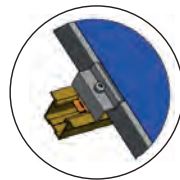
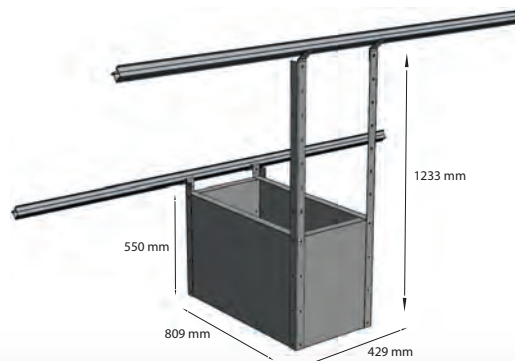

CONTACT

GSE
Intégration

GSE Intégration

155-159 rue du Dr Bauer, 93400 SAINT-OUEN FRANCE +33(0)1.49.48.14.51
contact@gseintegration.com - www.gseintegration.com

