

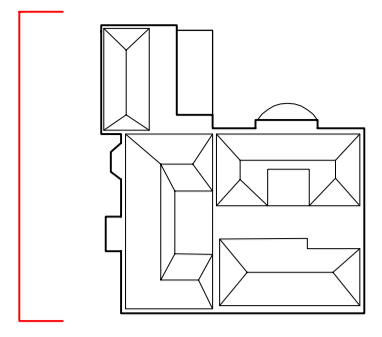

Existing casement door windows to be replaced to match existing. Refer to La Rosser subcontractor drawings 'Type 2 Section 1' and 'Type 2 Section 2' for details. New Gloucester Lounge and Vestibule Bar casement doors have considered the following to elements in order to match existing:

- Single glazed
- Glass pane to match match existing colour
- Bespoke South American mahogany rails
- Sill and capping strip painted externally with natural finish internally.
- Please refer also to EPR document entitled 'First Floor Window Replacement'

Keyplan



North

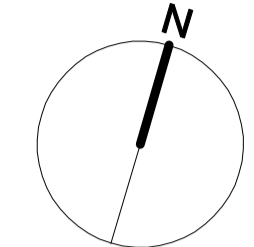

Notes:

Do not scale off this document/drawing/model for any purposes other than those required in connection with the application for planning consent for the project.

This document/drawing/model is prepared for the sole use of EPR Architects employer and the benefit of the employer's permitted licensees. No liability to any other persons is accepted by EPR Architects.

EPR Architects accepts no liability for any use of the document/drawing/model by parties other than the party for whom it was prepared or for purposes other than those for which it was prepared.

Copyright in the design contained in this document/drawing/model remains vested in EPR Architects.

Issue	Date	Initial	Chkd
P01 Issued for Planning	03.10.23	MC	EC
No Revision			

General Notes:

- This Drawing is to be read in conjunction with EPR document entitled 'First Floor Window Replacement'.
- This drawing will be read in conjunction with Smith Jenkins Planning and Heritage Historic Report.
- EPR Architects has prepared this document/drawing/model based on site information provided by a third party and which is included for reference purposes only. This site information has not been checked or verified by EPR Architects and EPR Architects accepts no liability for it.

**EPR ARCHITECTS**  
 +44 (0) 20 7932 7600  
 www.epr.co.uk

Home House First Floor Window Replacement  
 19, 20, & 21 Portman Square, Mayfair, London  
 W1H 6LW

Proposed West Elevation  
 S2 1: 200 @ A1 05.10.23

11712-EPR-00-WE-TPA-04-1002P01