

KEY

T672 Tree tag numbers

Tree categories as described in BS5837

- Category A
- Category B
- Category C
- Category U

- Root protection area, calculated to BS5837
- Trees retained
- Trees to be removed
- Protective fencing

NOTES
 This drawing originates as a colour document.
 Assumptions should not be made from grayscale reproductions.
 For further details please see:
 Hinselwood Arboricultural Consultants - Survey of Trees
 Diageo, Shieldhall 9th June 2023

Tree ID	Tag No.	Species	Category	Health	Location	Notes	Retention	Protection	Removal	Other
T672	T672	Ulmus	U	Good	Retain
T673	T673	Ulmus	U	Good	Retain
T674	T674	Ulmus	U	Good	Retain
T675	T675	Ulmus	U	Good	Retain
T676	T676	Ulmus	U	Good	Retain
T677	T677	Ulmus	U	Good	Retain
T678	T678	Ulmus	U	Good	Retain
T679	T679	Ulmus	U	Good	Retain
T680	T680	Ulmus	U	Good	Retain
T681	T681	Ulmus	U	Good	Retain
T682	T682	Ulmus	U	Good	Retain
T683	T683	Ulmus	U	Good	Retain
T684	T684	Ulmus	U	Good	Retain
T685	T685	Ulmus	U	Good	Retain
T686	T686	Ulmus	U	Good	Retain
T687	T687	Ulmus	U	Good	Retain
T688	T688	Ulmus	U	Good	Retain
T689	T689	Ulmus	U	Good	Retain
T690	T690	Ulmus	U	Good	Retain
T691	T691	Ulmus	U	Good	Retain
T692	T692	Ulmus	U	Good	Retain
T693	T693	Ulmus	U	Good	Retain
T694	T694	Ulmus	U	Good	Retain
T695	T695	Ulmus	U	Good	Retain
T696	T696	Ulmus	U	Good	Retain
T697	T697	Ulmus	U	Good	Retain
T698	T698	Ulmus	U	Good	Retain
T699	T699	Ulmus	U	Good	Retain
T700	T700	Ulmus	U	Good	Retain

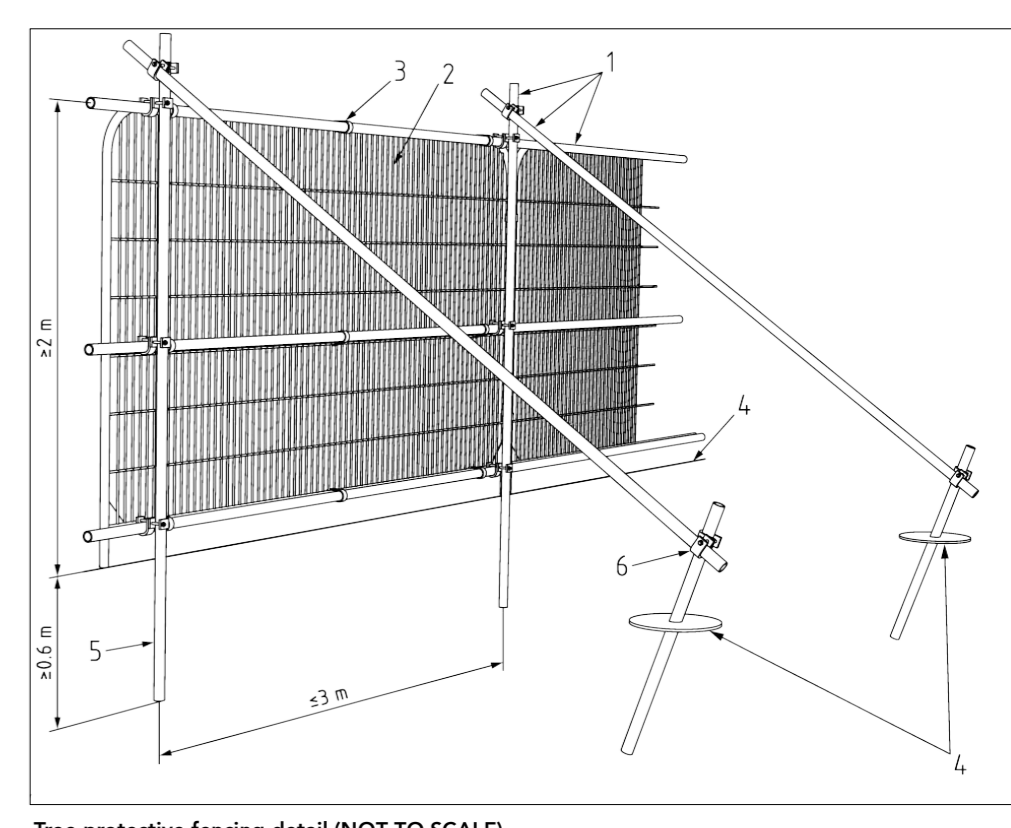

Tree protective fencing detail (NOT TO SCALE)

KEY

- Standard scaffold poles
- Heavy gauge 2m tall galvanized tube and welded mesh infill panels
- Panels secured to uprights and cross-members with wire ties
- Existing ground level
- Uprights driven into ground until secure (min. 600mm depth)
- Standard scaffold clamps

NOTES
 Tree protective fencing to Figure 3b of BS 5837:2012.
 Tree protective fences to be installed to the lines shown and remain in position for the entire construction phase.
 No materials storage or access shall be permitted within the exclusion zones.
 All-weather signs to be attached to the barriers at 10m centres with the following information:

**CONSTRUCTION
EXCLUSION ZONE -
NO ACCESS**

