



## **Appendix B – MRXBOX HYBRID COOLING SYSTEM**

## **Appendix C – Purge Ventilation Unit**

# Purge Ventilation Unit

Easy to install ventilation solution

## For use in residential dwellings

Titon's Purge ventilation unit has been designed to satisfy the Building Regulations Part F 2010 requirement for purging as set out in \*Appendix B. It allows the rapid removal of stale, odorous and poor quality air from the dwelling allowing a healthier more comfortable environment to be reinstated.

Our Purge unit can be used in an independent purge system in its own right or integrated into our own HRV Q Plus MVHR system to provide additional dedicated purge ventilation.

Purge ventilation can also be used to improve thermal comfort.

\*Manually controlled intermittent ventilation of rooms or spaces at a relatively high rate to rapidly dilute high concentrations of pollutants and/or water vapour from occasional activities, equivalent to 4 air changes an hour.

## Features & Benefits

- Low Profile
- High efficiency EC fan
- 100% variable speed control for commissioning set point
- 90° configurable option
- Accepts configurations of 220x90mm rectangular ducting and Ø150mm or 220x90mm with adaptor for 90° option
- For use in rooms up to 45m<sup>2</sup>
- In line configurable option
- Simple 1 setting setup
- Light weight for easy handling
- Easy and quick to install
- Low sound levels
- IPX2 water resistant

Purge



Ceiling cover kit available



Powered Damper Actuator

## Product Codes

- TP625** - Purge Unit
- TP629** - Ø150 Back Draft Damper
- TP630** - Powered Damper Actuator
- TP631** - Ceiling Cover Kit (Ø150 only)

## Standards

EU RoHS Directive Compliant.

Conforms to requirements of EC council Directives relating to electromagnetic Compatibility and Electrical Safety:  
 2006/95/EC (LVD), 2004/108/EC (EMC)  
 EN 60335-1:2002/A2:2006, EN 60335-2-80:2003/A1:2004.

CE Marked.

## Specification

### Dimensions:

510mm long x 300mm Wide x 150mm Deep

**Weight:** 7.2Kg

**Finish:** Natural Zintec

**Materials:** Zintec sheet steel casing

**Guarantee Period:** 2 Years

**Electrical:** 230V - 50/60Hz, 3A fuse

**Maintenance:** Service subject to local environment - see product manual.

## Performance

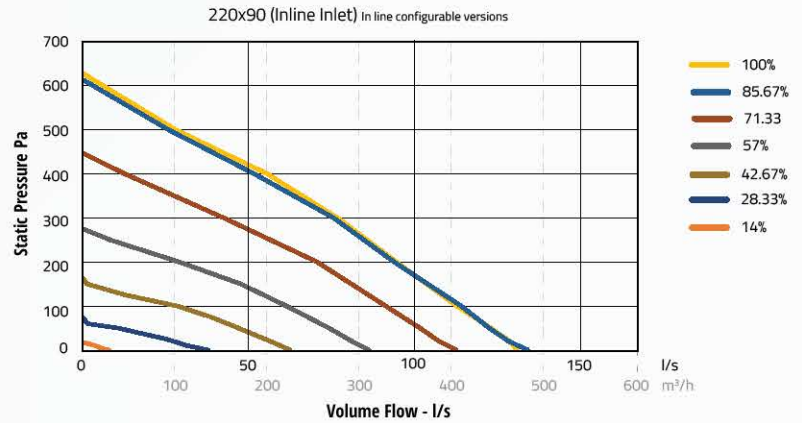
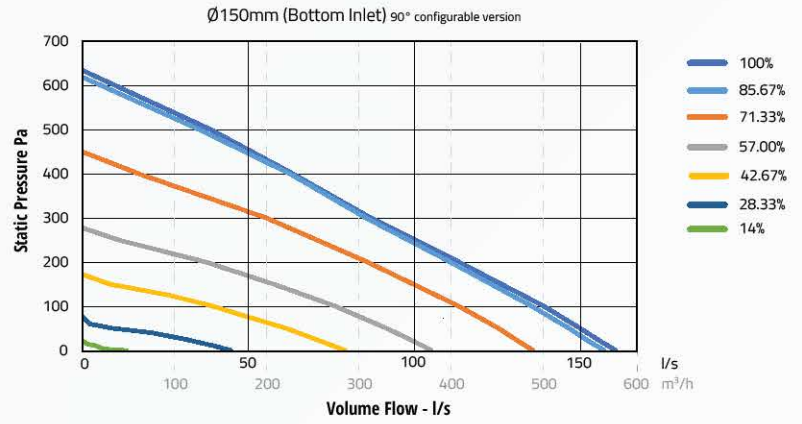

## Drawing and Dimensions

### Purge Ventilation Unit

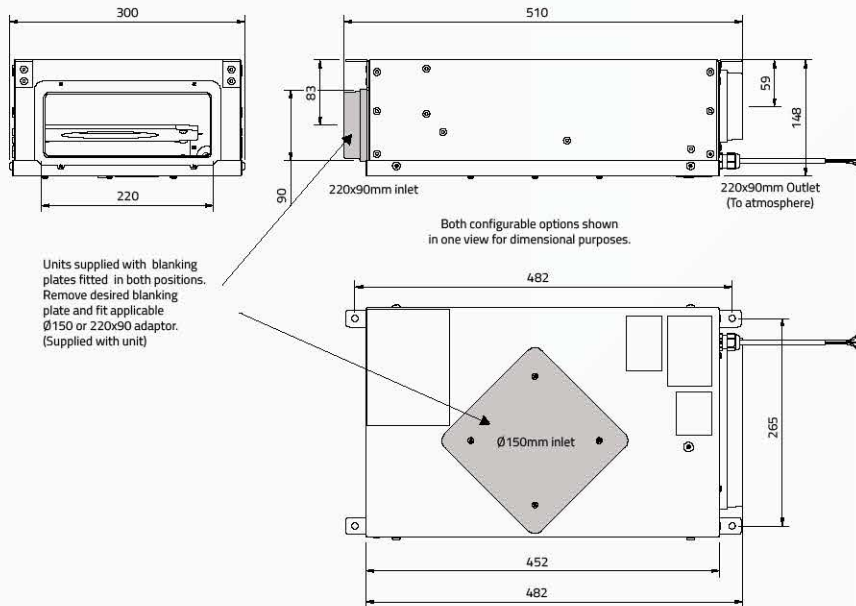

### Powered Damper Actuator

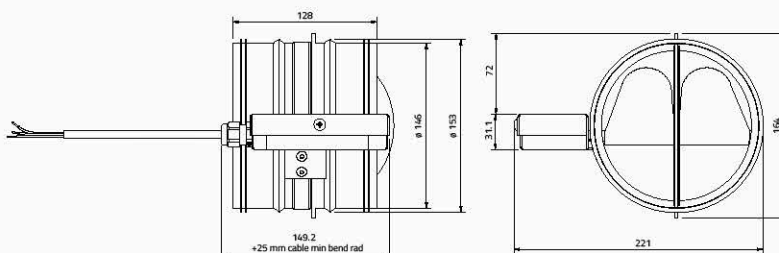

Dimensions in mm





**MRXBOX  
HYBRID  
COOLING  
SYSTEM**



CONTENTS

# PROUD TO BUILD BRITISH

3	UNDERSTANDING OVERHEATING
4	WHAT IS THE SOLUTION?
6	HOW NUAIRE'S MRXBOX HYBRID COOLING SYSTEM CAN HELP
8	CONSULTANT SPECIFICATION

We've been pioneers in new air technology since 1966. Our heritage is in the design and manufacture of fans and ventilation systems. *We put our energy into efficient ventilation so you don't waste yours.*



**Pioneering**  
We lead the way in product innovation with a stream of ground-breaking products over decades.



**Trusted**  
We have a reputation for our build quality. We establish long term relationships and are always transparent with our test data.



**Agile**  
We're one of the UK's leading manufacturers, covering both residential and commercial air quality. We offer innovative advice and provide flexible solutions.



**Expert**  
Our team is made up of over 600 people, 50 of which have over 25 years' experience. We have the skills and knowledge to help find the best solution for our customers.



**Attentive**  
We're expert listeners, rising to any challenge and going the extra mile for our customers. We add value by solving problems. We sell solutions, not fans.



**Personal**  
We work closely with our customers and can provide bespoke solutions to meet their specific project needs. Many of our product ranges were developed this way.

“Our expertise, experience and innovation are what makes us stand out from the rest of the market.”

Nuaire.



For help with selecting a unit, speak to us on 029 2085 8500 or email: [residential.enquiries@nuaire.co.uk](mailto:residential.enquiries@nuaire.co.uk)

# UNDERSTANDING OVERHEATING



The tendency for new build dwellings, especially apartments, to reach uncomfortable internal temperatures during summer is an increasing problem in need of a solution.

Daytime internal heat build-up leads to night-time temperatures too high for comfortable sleep, adding to heat stress and increasing the risk to health. Single aspect dwellings with large glazing are particularly susceptible.

The move to ever higher levels of thermal insulation and airtightness, coupled with external factors such as environmental and noise pollution make it difficult to control internal temperatures by natural means.

Overheating in apartments presents a challenge to developers and causes misery for occupants. As global temperatures rise, the problem will only get worse.





# WHAT IS THE SOLUTION?

Internal temperatures targeted year-round by conventional MVHR, even those with summer bypass, can contribute to internal heat build-up in summer.

Nuaire's MRXBOX Hybrid Cooling System combines year-round high levels of indoor air quality with the added benefit of summer cooling to mitigate overheating.

This added cooling significantly lowers the temperature of fresh air supplied into the dwelling, helping maintain comfortable internal temperature levels even in city centre apartments on the hottest days of summer.

## THE CONTINUING PROBLEM OF OVERHEATING IS WELL KNOWN THROUGHOUT THE INDUSTRY.

**MRXBOX HYBRID COOLING HELPS PROVIDE A SIMPLE SOLUTION.**

THE CONTINUED DRIVE TOWARDS HIGHLY INSULATED AND BETTER SEALED HOMES WITH LARGE AREAS OF GLAZING HAS GIVEN RISE TO OVERHEATING IN HOMES.



“ This added cooling significantly lowers the temperature of fresh air supplied into the dwelling. ”



# HOW NUAIRE'S MRXBOX HYBRID COOLING SYSTEM CAN HELP

The below selection tables provide typical cooling data based on sample conditions. For project specific information, contact one of our Estimators on **029 2085 8500** or email [residential.enquiries@nuaire.co.uk](mailto:residential.enquiries@nuaire.co.uk).

## 29°C EXTERNAL AIR TEMPERATURE

Conditions	Cooling (kW) / Airflow Rates (l/s)	50	60	70	80	90	100	110	120
23°C Internal	Combined kW	0.88	1.03	1.17	1.29	1.40	1.49	1.57	1.62
	Supply air °C	14.3	14.8	15.2	15.7	16.2	16.7	17.2	17.8
24°C Internal	Combined kW	0.82	0.98	1.12	1.24	1.34	1.43	1.49	1.53
	Supply air °C	15.0	15.4	15.9	16.3	16.8	17.3	17.8	18.4
25°C Internal	Combined kW	0.80	0.95	1.07	1.18	1.27	1.34	1.39	1.43
	Supply air °C	15.5	15.9	16.4	16.9	17.4	18.0	18.5	19.1
26°C Internal	Combined kW	0.78	0.91	1.02	1.11	1.19	1.25	1.30	1.33
	Supply air °C	15.9	16.4	17.0	17.5	18.1	18.6	19.2	19.8

## 32°C EXTERNAL AIR TEMPERATURE

Conditions	Cooling (kW) / Airflow Rates (l/s)	50	60	70	80	90	100	110	120
23°C Internal	Combined kW	1.03	1.21	1.37	1.51	1.63	1.73	1.82	1.88
	Supply air °C	15.0	15.3	15.8	16.3	17.0	17.7	18.4	19.1
24°C Internal	Combined kW	0.98	1.14	1.29	1.42	1.54	1.65	1.74	1.82
	Supply air °C	16.0	16.4	16.8	17.2	17.8	18.3	18.9	19.6
25°C Internal	Combined kW	0.93	1.09	1.24	1.37	1.49	1.60	1.69	1.77
	Supply air °C	16.6	17.0	17.4	17.9	18.3	18.8	19.3	19.9
26°C Internal	Combined kW	0.88	1.04	1.19	1.32	1.44	1.55	1.64	1.72
	Supply air °C	17.3	17.7	18.1	18.5	18.9	19.3	19.7	20.2

## 34°C EXTERNAL AIR TEMPERATURE

Conditions	Cooling (kW) / Airflow Rates (l/s)	50	60	70	80	90	100	110	120
23°C Internal	Combined kW	1.13	1.31	1.49	1.65	1.80	1.94	2.08	2.20
	Supply air °C	15.4	15.9	16.4	16.9	17.4	17.9	18.4	18.9
24°C Internal	Combined kW	1.11	1.27	1.43	1.59	1.73	1.87	2.00	2.12
	Supply air °C	16.0	16.5	17.0	17.5	18.0	18.5	19.0	19.5
25°C Internal	Combined kW	1.04	1.21	1.37	1.52	1.65	1.77	1.89	1.99
	Supply air °C	16.9	17.4	17.9	18.4	18.9	19.4	19.9	20.4
26°C Internal	Combined kW	0.97	1.15	1.31	1.45	1.57	1.68	1.77	1.85
	Supply air °C	17.8	18.3	18.8	19.3	19.7	20.2	20.7	21.2

6 Note: Typical External Ambient temperatures stated above are Dry Bulb. Combined kW = Combined Coolth recovery and sensible cooling. No allowance has been made for latent losses at supply air temperatures below the dew point. Consult Nuair for cooling output data at your assumed external design conditions. A supply air temperature of 16°C or above is recommended for good air distribution.

## PERFORMANCE

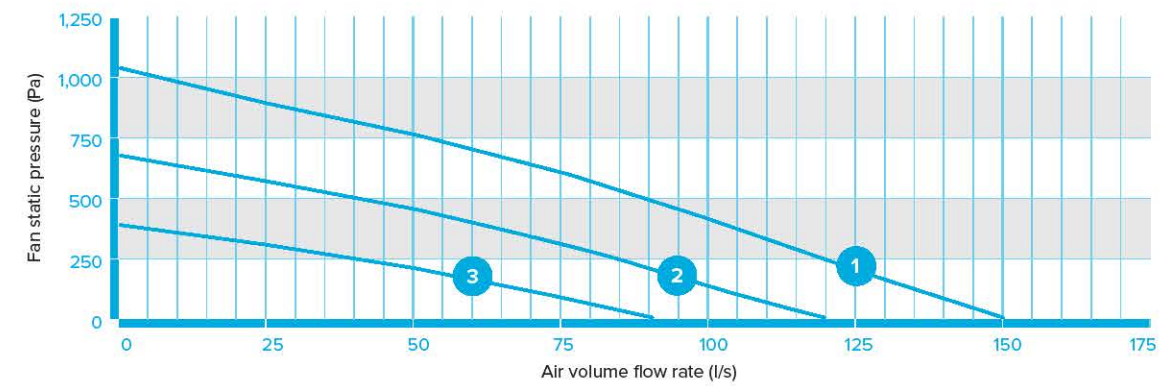

## ELECTRICAL AND SOUND DATA

Curve	MVHR Power Consumption (Watts)	Sound Power Levels dB re 1pW (Frequency Hz)								Hemispherical dBA @ 3m	
		63	125	250	500	1k	2k	4k	8k		
1	319	Breakout	66	65	56	52	39	35	29	21	36
		Open Inlet	58	58	58	53	49	38	30	24	
		Open Outlet	58	61	61	71	60	52	49	44	
2	167	Breakout	66	65	54	49	37	34	26	18	34
		Open Inlet	56	58	58	53	47	37	26	19	
		Open Outlet	58	61	61	71	59	52	48	43	
3	77	Breakout	65	65	54	45	34	30	22	<16	33
		Open Inlet	56	56	55	49	45	32	21	<16	
		Open Outlet	56	59	62	66	54	50	41	41	

Cooling module motor input power 650W. Above data refers to vertical units. Please contact Nuair for performance data on the in-line version. The breakout case-radiated dBA values are given for Hemispherical free field radiation at 3m - to obtain the Spherical radiated data, subtract 3 dBA. Please note: Sound data is provided at a particular duty point, with the cooling module running, approximately 60%, 80% and 100%. For accurate sound data at a specific duty, please use Nuair's fan selector or call the office on 029 2085 8500.

## DIMENSIONS (mm)

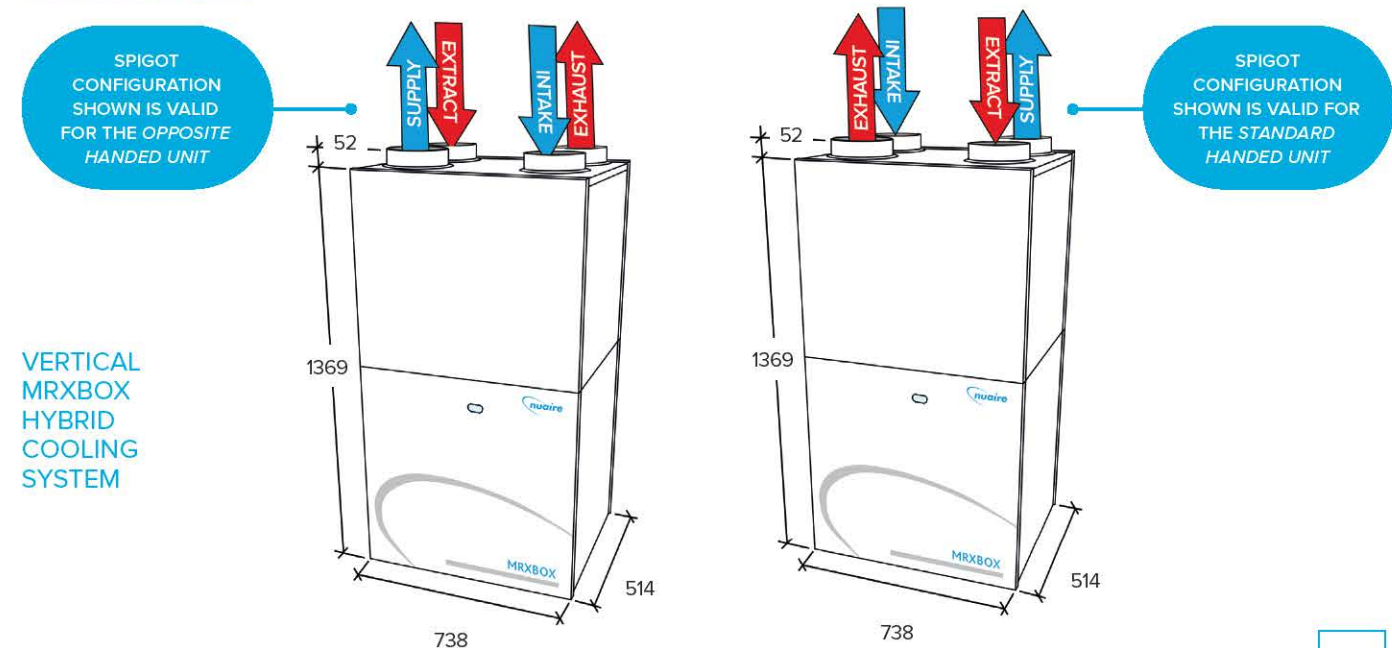

Combined MRXBOXAB-ECO5-AECV and MR-ECO-COOL-V weight 121Kg.





# MRXBOX HYBRID COOLING SYSTEM CONSULTANT SPECIFICATION

### OPERATION

The MVHR unit shall be fully insulated providing excellent thermal and acoustic characteristics and shall be complete with a multi plate counter flow high efficiency heat exchanger block, with a thermal efficiency of up to 95%. The heat exchanger shall be protected by filters on fresh air inlet and system extract. The heat exchanger and filters shall be accessible via the front access panel, enabling quick and easy maintenance.

The unit shall have low energy, high efficiency EC fan/motor assemblies with sealed for life bearings, the impellers shall be backward curved centrifugal type. The motors shall be suitable for an ambient temperature of 40°C.

The unit shall be supplied complete with a condensate drip tray and 21.5mm drain connection.

The unit shall be suitable for 150mm circular ducting. The breakout noise level and power requirements shall be as detailed by the unit manufacturer and in accordance with the ventilation equipment schedule.

The unit shall be provided within a white pre-painted or coated steel acoustic enclosure lined with a minimum of 20mm class 'O' acoustic foam insulation to reduce breakout noise.

Flexible duct connections shall be within the enclosure, pre-fitted between the MVHR unit and the connection spigots on the top face of the enclosure.

(Removing the need for flexible duct connectors outside of the unit which may cause breakout).

The MVHR unit shall be retained within the enclosure on a metal tray supported on turret type anti-vibration mounts of suitable deflection to ensure that vibration is not transmitted to the supporting structure.

All operational components of the MVHR unit shall be accessible via the front panel of the enclosure.

Bypass operation can be manually overridden via an external switch in colder months so the unit continually recovers heat.

The MVHR unit shall be offered with a five year warranty. The product warranty applies to the UK mainland and in accordance with Clause 14 of our Conditions of Sale. Customers purchasing from outside of the UK should contact Nuair International Sales office for further details.

The Cooling module shall mount directly on-top-of, and operate in conjunction with, the MVHR unit. On/Off control of cooling and room temperature set-point shall be by adjustable wall mounted cooling-stat. Control links between MVHR and cooling module shall activate a higher airflow when cooling is enabled and inhibit operation of the cooling module in the event of fan failure.

The maximum coolth-recovery and sensible cooling of the MVHR and cooling module, combined, shall be in excess of 2 kW.

The Cooling module shall incorporate a sealed-for-life R134a cooling circuit and a double-skinned casing with class 'O' fire-rated acoustic foam lining to minimize noise breakout.

Inner panels shall be thermally insulated to prevent condensation. The module shall have 150mm diameter circular duct connections.

The cooling module shall include an integral condensate tray and drain with a 15mm connection pipe. Condenser and evaporator coils shall be accessible for cleaning from the front of the unit irrespective of orientation.

All maintainable components shall be accessible in situ. It shall not be necessary to remove or withdraw cooling components from the casing for cleaning.

The cooling module shall include a factory fitted foam base-gasket to effect an airtight seal between module and matching MVHR. The module shall be supplied with mounting brackets, to ensure that it is mechanically fixed to the MVHR and an upper restraining bracket to be fitted between the module and the wall.

The MVHR and Cooling module assembly shall be supported on unit-specific floor-mounting stand, unit-specific prefabricated steel cantilever brackets or other suitable fabricated steel supporting frame.

The cooling module shall be supplied with a two year (parts only) warranty.

The product warranty applies to the UK mainland and in accordance with Clause 14 of our Conditions of Sale. Customers purchasing from outside of the UK should contact Nuair International Sales office for further details.

### NOTES

Multiple horizontal lines for notes.









**INTERNATIONAL**

[WWW.NUAIRE.CO.UK/INTERNATIONAL](http://WWW.NUAIRE.CO.UK/INTERNATIONAL)



**COMMERCIAL**

[WWW.NUAIRE.CO.UK/COMMERCIAL](http://WWW.NUAIRE.CO.UK/COMMERCIAL)



**RESIDENTIAL**

[WWW.NUAIRE.CO.UK/RESIDENTIAL](http://WWW.NUAIRE.CO.UK/RESIDENTIAL)



WESTERN INDUSTRIAL ESTATE | CAERPHILLY | CF83 1NA  
**T** 029 2085 8500 **F** 029 2085 8300 **E** [INFO@NUAIRE.CO.UK](mailto:INFO@NUAIRE.CO.UK)  
[WWW.NUAIRE.CO.UK](http://WWW.NUAIRE.CO.UK)



# GET IN TOUCH **TODAY**



01634 727255

[mail@waterstonedesign.co.uk](mailto:mail@waterstonedesign.co.uk)

[www.waterstonedesign.co.uk](http://www.waterstonedesign.co.uk)

