

NOTES:
 This drawing is the property of Form Design Consultants and should not be replicated without their permission.
 The Main Contractor is responsible for the coordination of the construction on site. Contractors must verify all dimensions before commencing and seek clarification or notify Form Design Consultants if site discrepancies are noted. Contractors must not scale from this drawing.

Drawing Status	
Information	
Approval	
Warrant	
Planning	
Tender	
Contract	
Construction	
Record Drawing	

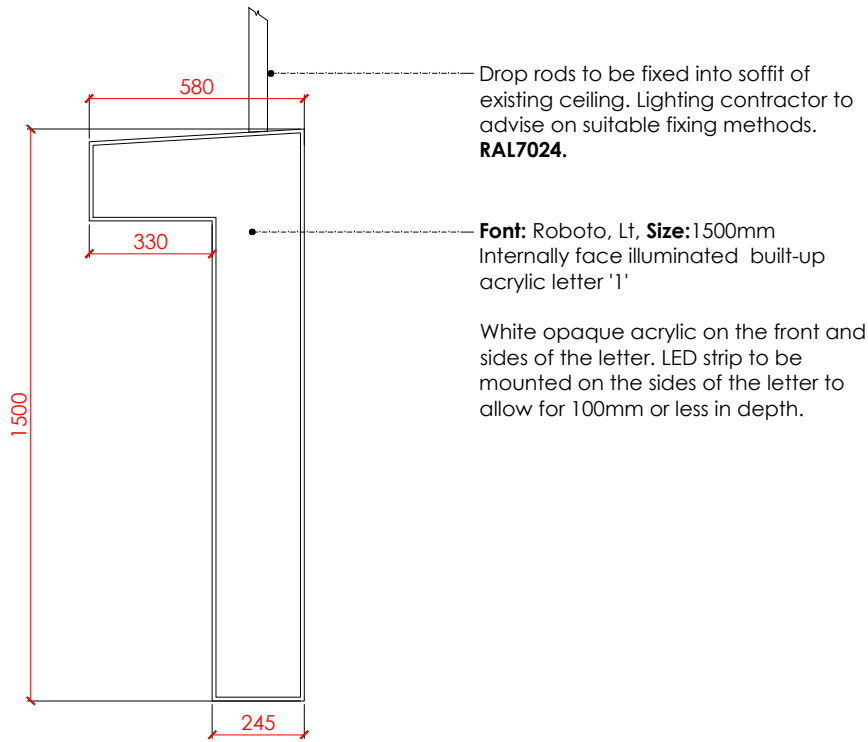

Drop rods to be fixed into soffit of existing ceiling. Lighting contractor to advise on suitable fixing methods. **RAL7024.**

Font: Roboto, Lt, **Size:** 1500mm
 Internally face illuminated built-up acrylic letter '1'

White opaque acrylic on the front and sides of the letter. LED strip to be mounted on the sides of the letter to allow for 100mm or less in depth.

ILLUMINATED '1' SIGNAGE ELEVATION A @ 1:20

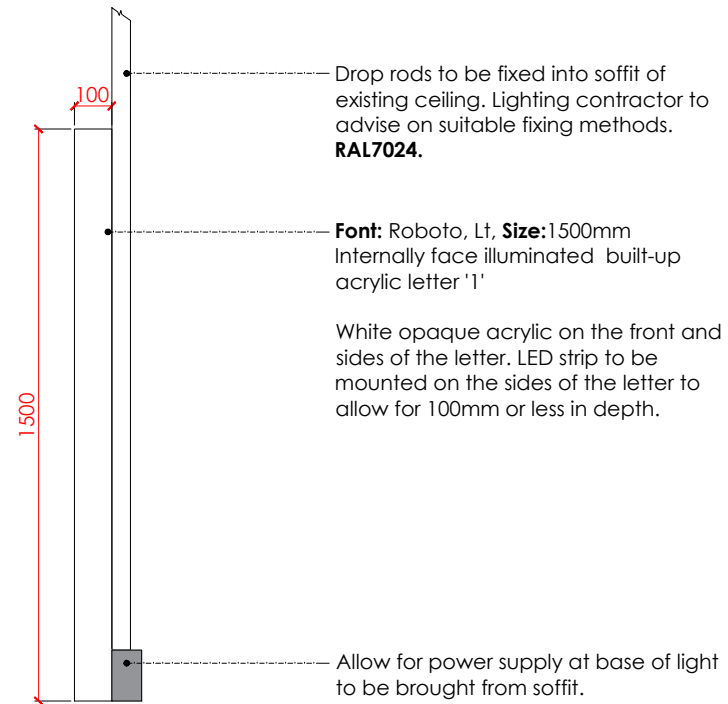

Drop rods to be fixed into soffit of existing ceiling. Lighting contractor to advise on suitable fixing methods. **RAL7024.**

Font: Roboto, Lt, **Size:** 1500mm
 Internally face illuminated built-up acrylic letter '1'

White opaque acrylic on the front and sides of the letter. LED strip to be mounted on the sides of the letter to allow for 100mm or less in depth.

Allow for power supply at base of light to be brought from soffit.

ILLUMINATED '1' SIGNAGE ELEVATION B @ 1:20

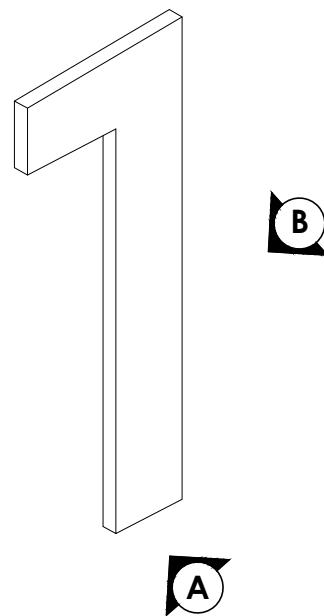

ILLUMINATED '1' SIGNAGE @ NTS

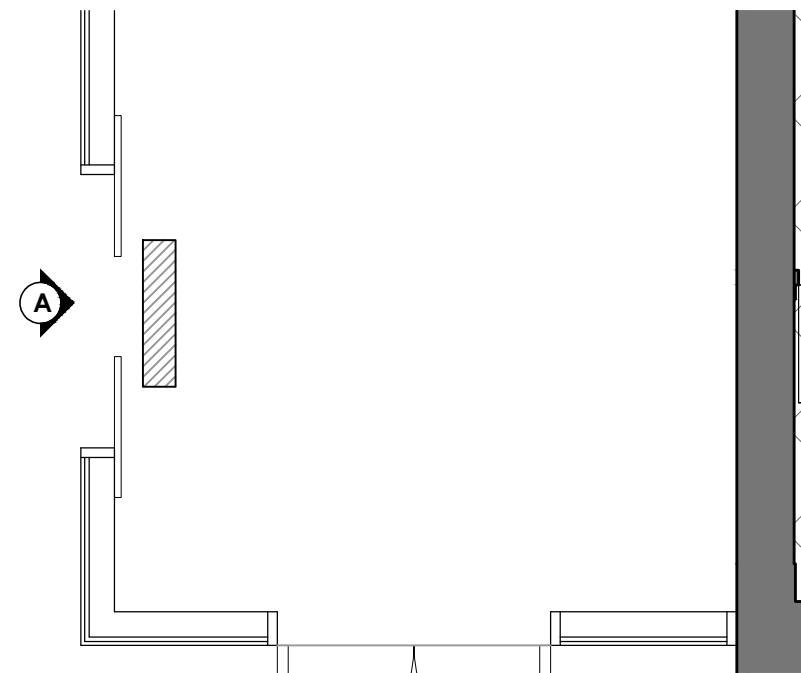

ILLUMINATED '1' SIGNAGE LOCATION PLAN @ NTS

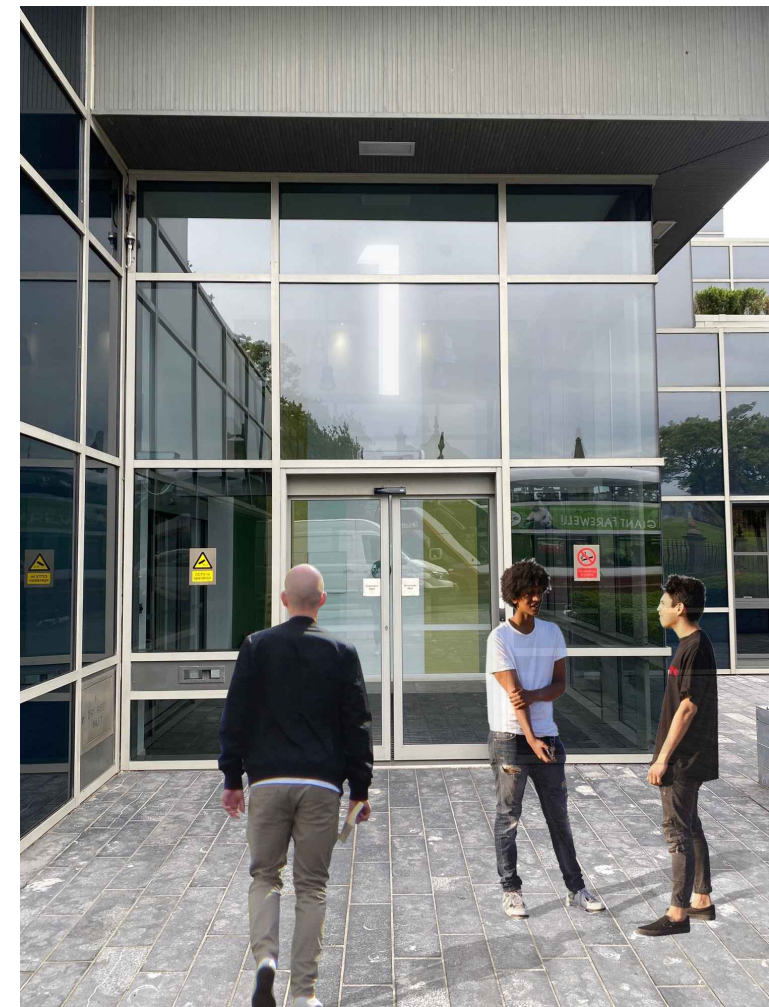

ILLUMINATED '1' SIGNAGE EXTERNAL VISUAL

Revision 0	Date 04.12.23	By KG	Ckd -
First Issue.			
Client:			
Patrizia, 166 Sloane Street London SW1X 9FQ			
Project:			
Apex 1 & 3 Receptions, Bike Stores and Parking and Terrace Areas			
Title:			
Apex 1 Illuminated Signage Elevations			
-			
Scale:	Date:		
1:20	@ A3	08.11.23	
Drawn By:	Checked By:		
KM	KG		
Drawing No:	Revision:		
13565.AD.02	0		

form

27/2 George Street, Edinburgh, EH2 2PA
 Tel: +44 (0)131 602 7003