

APPROACH FROM THE SOUTH, REVERSE MANOEUVRE ONTO BELGRAVE MEWS SOUTH AND TRAVEL TO SITE

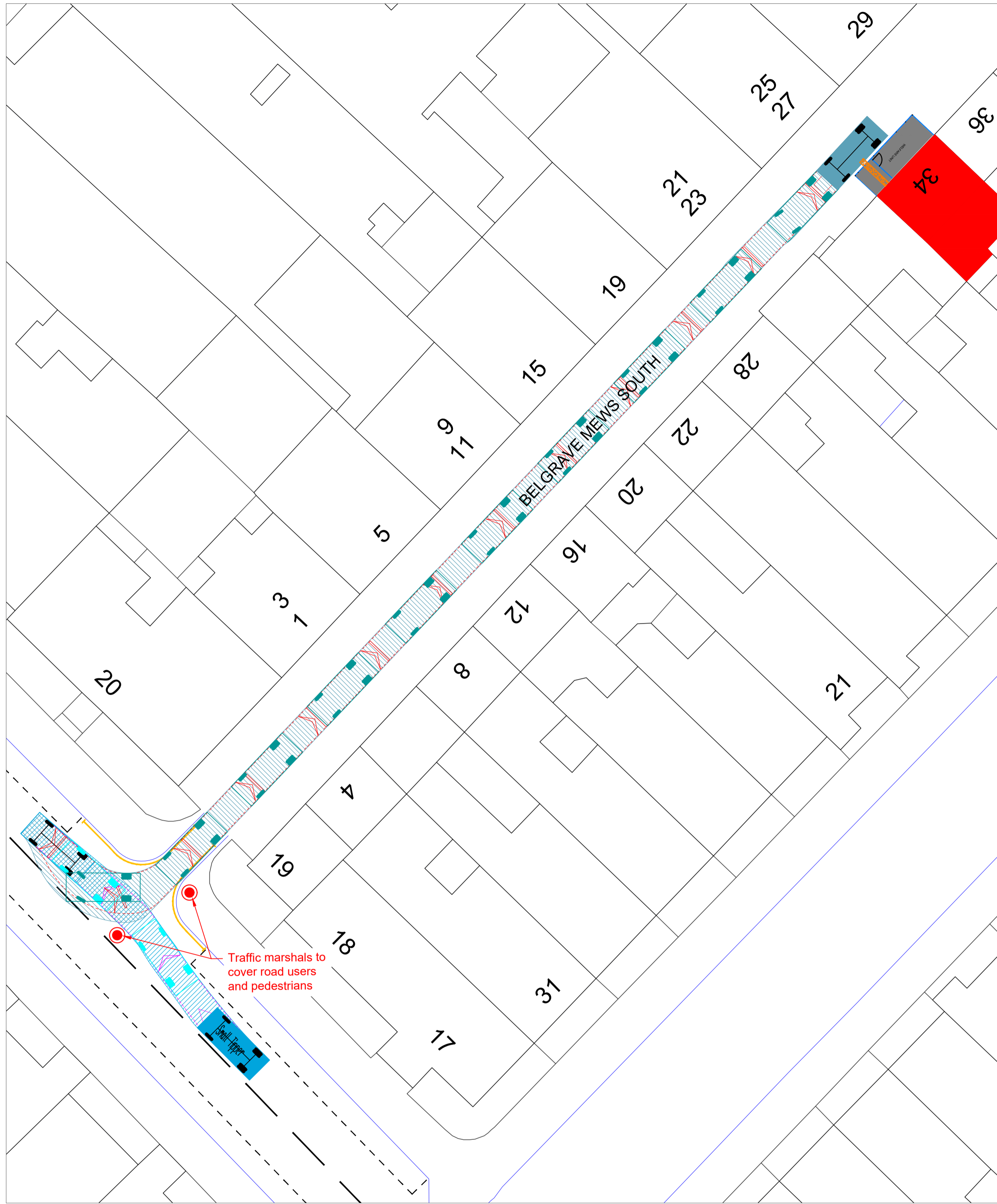

EXIT BELGRAVE MEWS SOUTH IN FORWARD GEAR TURNING RIGHT NORTHBOUND

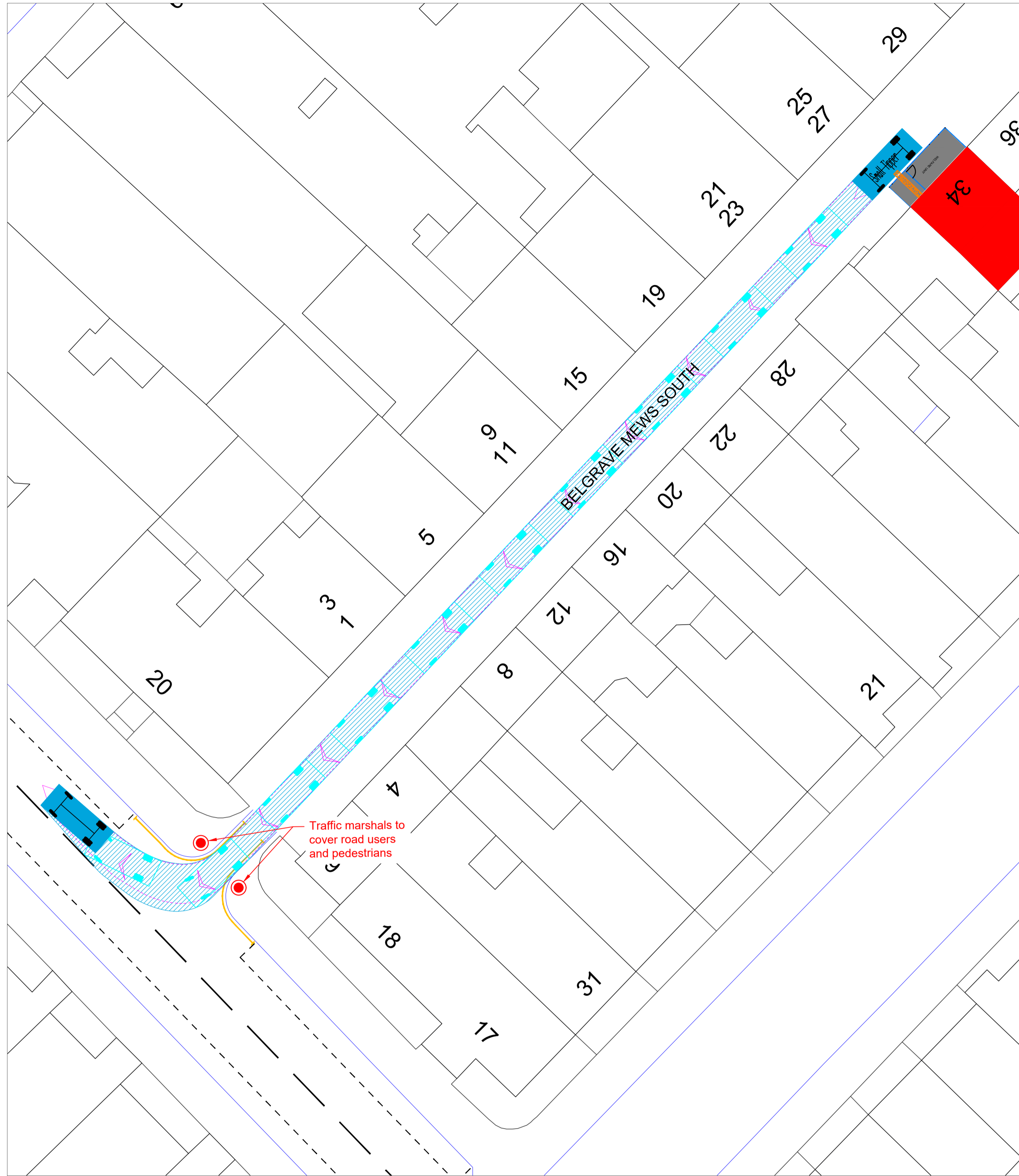

Traffic marshals to cover road users and pedestrians

Traffic marshals to cover road users and pedestrians

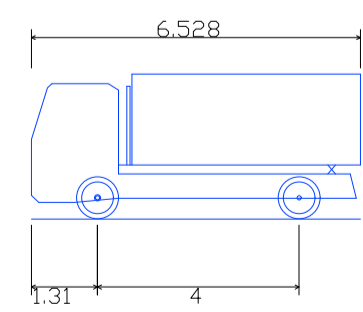

Small Tipper
 Overall Length 6.528m
 Overall Width 1.31m
 Overall Body Height 2.00m
 Min Body Ground Clearance 0.327m
 Track Width 1.393m
 Lock to lock time 6.00s
 Kerb to Kerb Turning Radius 7.850m

KEY TO VEHICLE ENVELOPES

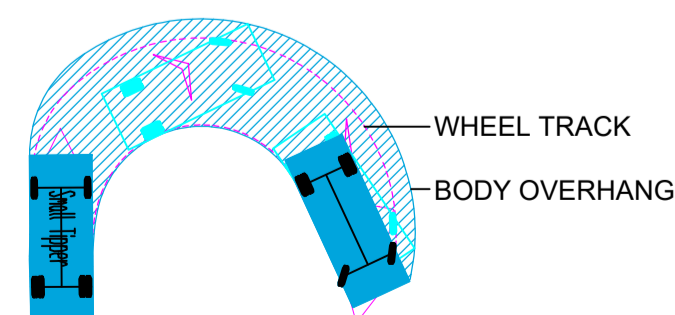

WHEEL TRACK IN FORWARD GEAR
 WHEEL TRACK IN REVERSE GEAR
 VEHICLE BODY IN FORWARD GEAR
 VEHICLE BODY IN REVERSE GEAR

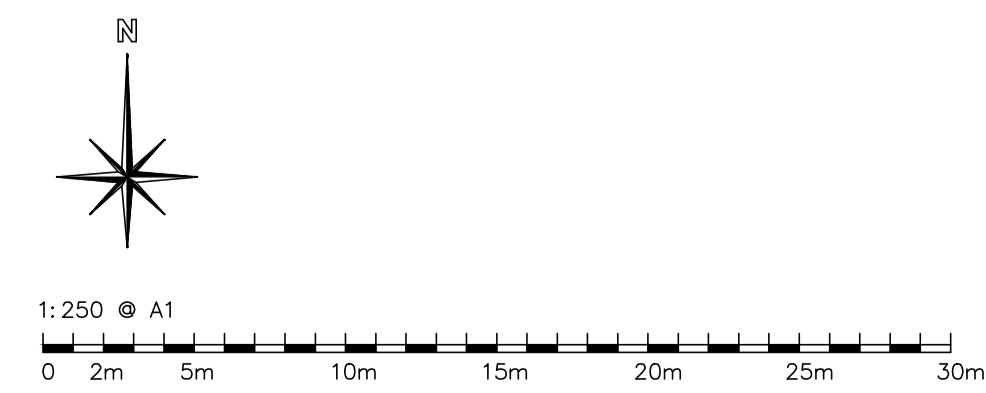
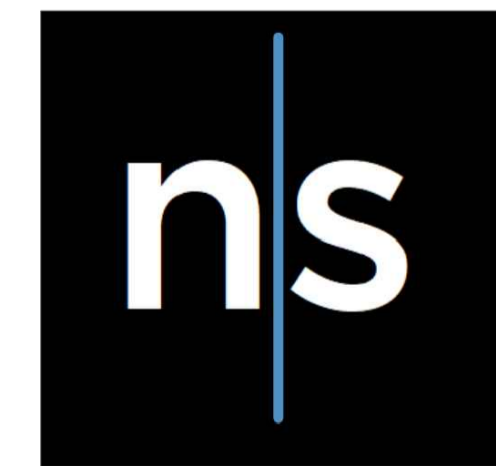

CLIENT:
NOBLE STRUCTURES

PROJECT:
34 BELGRAVE MEWS SOUTH, LONDON SW1

TITLE:
SWEEPED PATH ANALYSIS

DESCRIPTION:
SMALL TIPPER (MUCK AWAY) 6.5M

STATUS:
PLANNING

DATE: 09.11.23 DRAWN BY: JG
 JOB NO: JG.109.23 SCALE: 1:250 @ A1
 REV: - DRAWING NO: JG02

NOTES

1. This drawing and any ancillary drawings or data are copyright of JG Highway Design Ltd, and may not be used, copied, or amended for any purpose whatsoever without written approval.
2. This drawing is only to be used for the purposes described in the status box above.
3. Work to figured dimensions only. All dimensions and levels to be checked on site by the contractor before commencement of any work. If in doubt, ask.
4. This drawing is to be read in conjunction with all other drawings, details and specifications pertaining to the work described. It should only be used for the purpose marked in the status box above and shall not be used for construction unless clearly marked CONSTRUCTION.
5. Materials and workmanship shall comply to the appropriate British Standards and Codes of Practice unless otherwise stated.
6. The activities required to construct the work, shown on drawings clearly marked CONSTRUCTION, may be subject to the provisions of the Construction (Design & Management) Regulations 2015. The Contractor and Client must ensure that they are adequately conversant with these regulations and that the appropriate procedures required under the regulations are always observed.
7. Swept path analysis: When generic vehicles are used for swept path analysis, they may differ from specific makes and models of that type. Driver ability can vary hugely. What one driver is capable of, another may not be so any analysis shown to be tight on space will come down driver ability and the difference between make and models of vehicles.
8. UTILITIES NOTE: The position of any existing public or private sewers, utility services, plant or apparatus shown on this drawing is believed to be correct, but no warranty to this is expressed or implied. Other such plant or apparatus may also be present but not shown. The Contractor is therefore advised to undertake his own investigation where the presence of any existing sewers, services, plant, or apparatus may affect his operations.
9. Printed drawings not valid in black and white.

REVISIONS