

General
 Drawings prepared for local authority. Any electrical, heating installation, joinery items, finishes, and fittings to be instructed by the client. The clients are to satisfy themselves that any bonded private or public services will not affect the proposal. These drawings have been prepared on the understanding that work will not commence on site prior to the granting of planning permission and building reg approval. All drawings are copyrights and may not be used in conjunction with other projects.

CDM REG 2015
 These drawings have been prepared on the understanding that work will not commence on site prior to the granting of planning permission and building Reg approval. At this point the designers work is complete, hence the designer of this drawing will not be acting as the principle designer in terms of health and safety. Under the new regulations, both the client and the building contractor will have health and safety responsibilities and will need to prepare a construction phase plan for the scheme, the construction phase plan for the scheme should include risk assessment and method statements for elements of the works such as excavations, buried services, risk of electrocution, working at height, lifting and handling, etc. should you require guidance, please see HSE website.

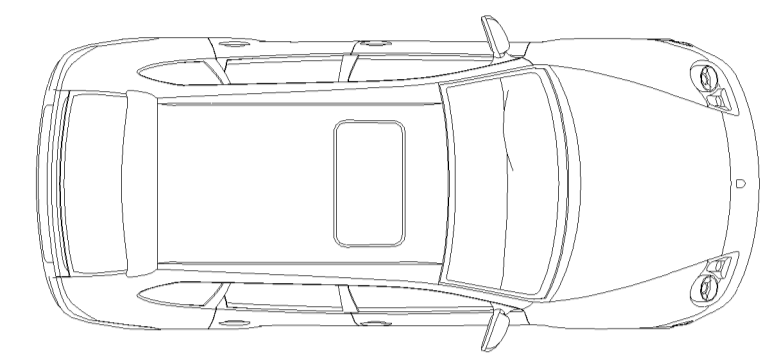

PLOT 2

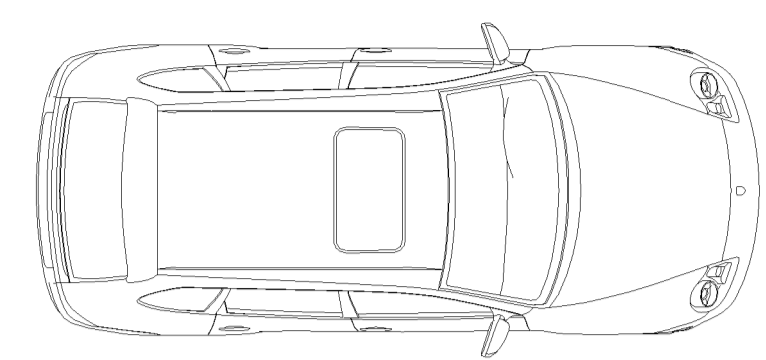
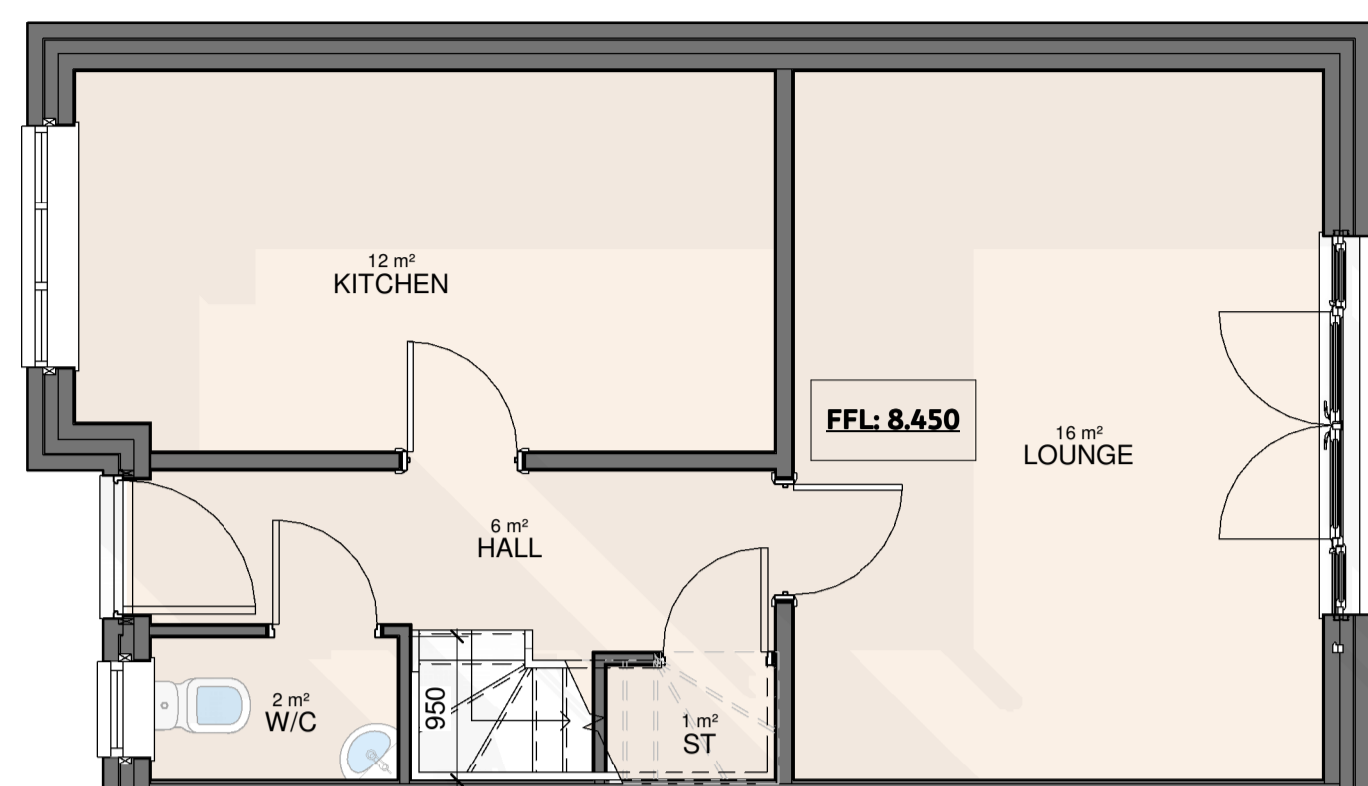

REAR GARDEN

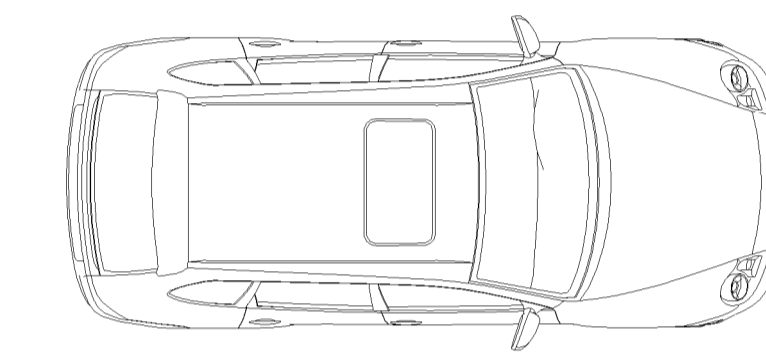
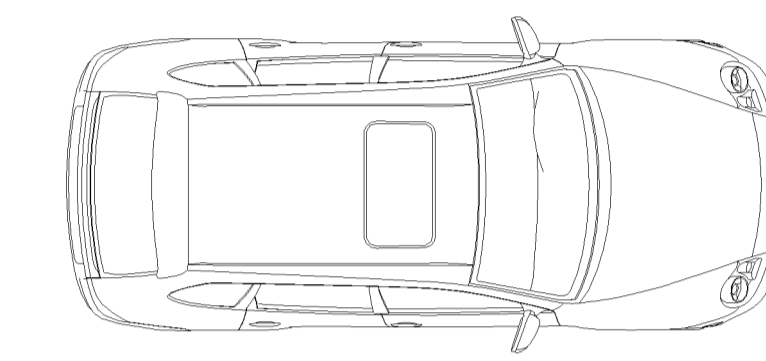

PLOT 1

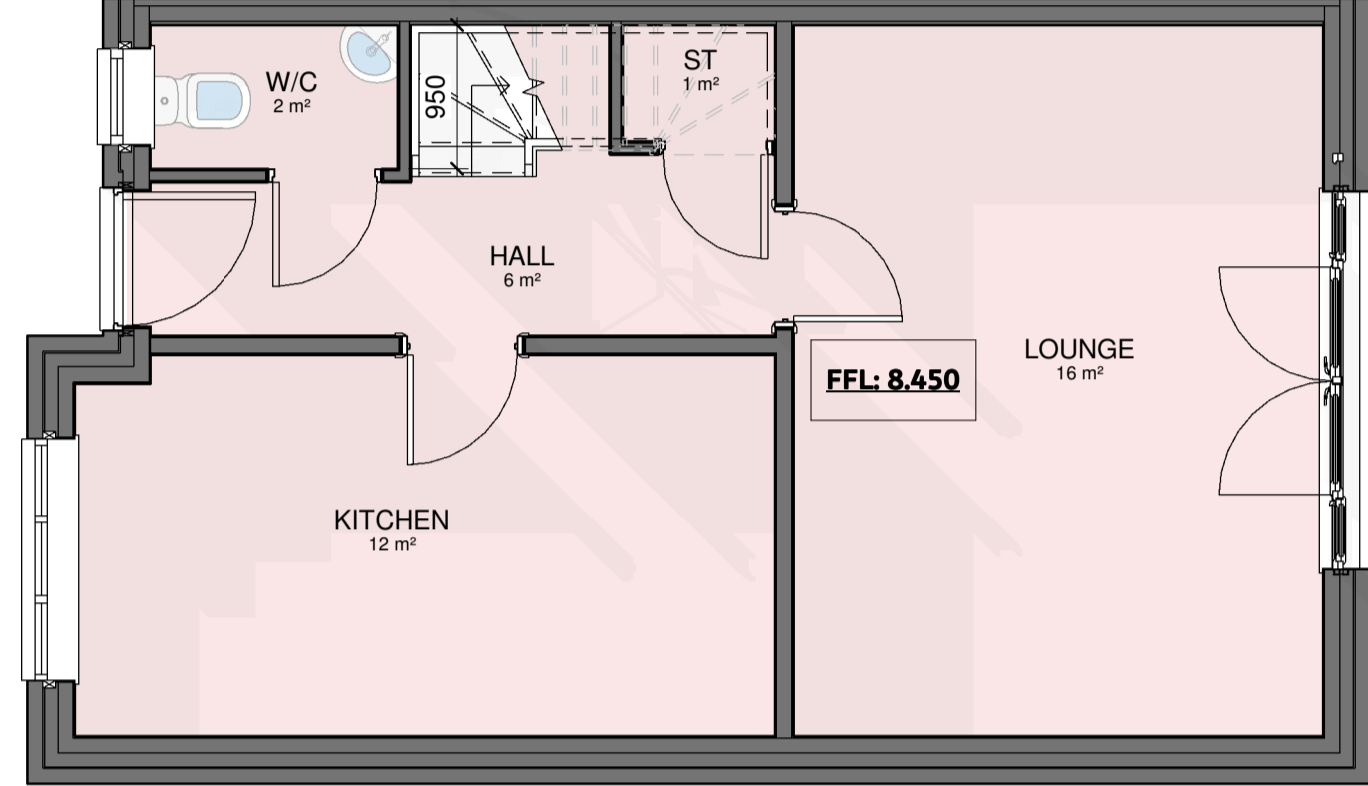

REAR GARDEN

Area Schedule (GIA) - PLOT 2

Department	Name	Area
PLOT 2	BED 1	16 m ²
PLOT 2	LOUNGE	16 m ²
PLOT 2	BED 2	12 m ²
PLOT 2	KITCHEN	12 m ²
PLOT 2	HALL	6 m ²
PLOT 2	HALL	4 m ²
PLOT 2	BATH	4 m ²
PLOT 2	W/C	2 m ²
PLOT 2	ST	1 m ²
Grand total: 9		72 m ²

Area Schedule (GIA) - PLOT 1

Department	Name	Area
PLOT 1	LOUNGE	16 m ²
PLOT 1	BED 1	16 m ²
PLOT 1	KITCHEN	12 m ²
PLOT 1	BED 2	12 m ²
PLOT 1	HALL	6 m ²
PLOT 1	HALL	4 m ²
PLOT 1	BATH	4 m ²
PLOT 1	W/C	2 m ²
PLOT 1	ST	1 m ²
Grand total: 9		72 m ²

PLOT 1 & 2 - 00 GROUND FLOOR
1 : 50

PLOT 2

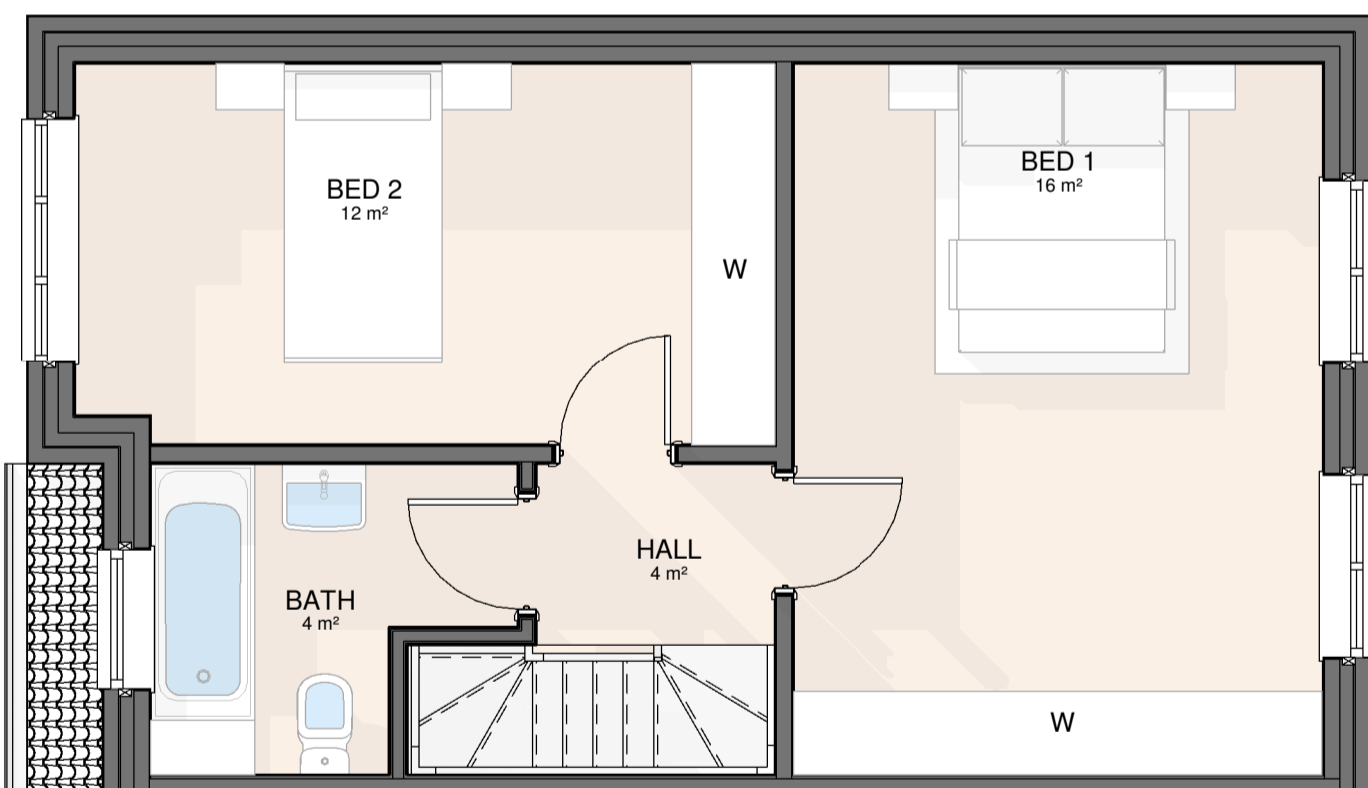

PLOT 1

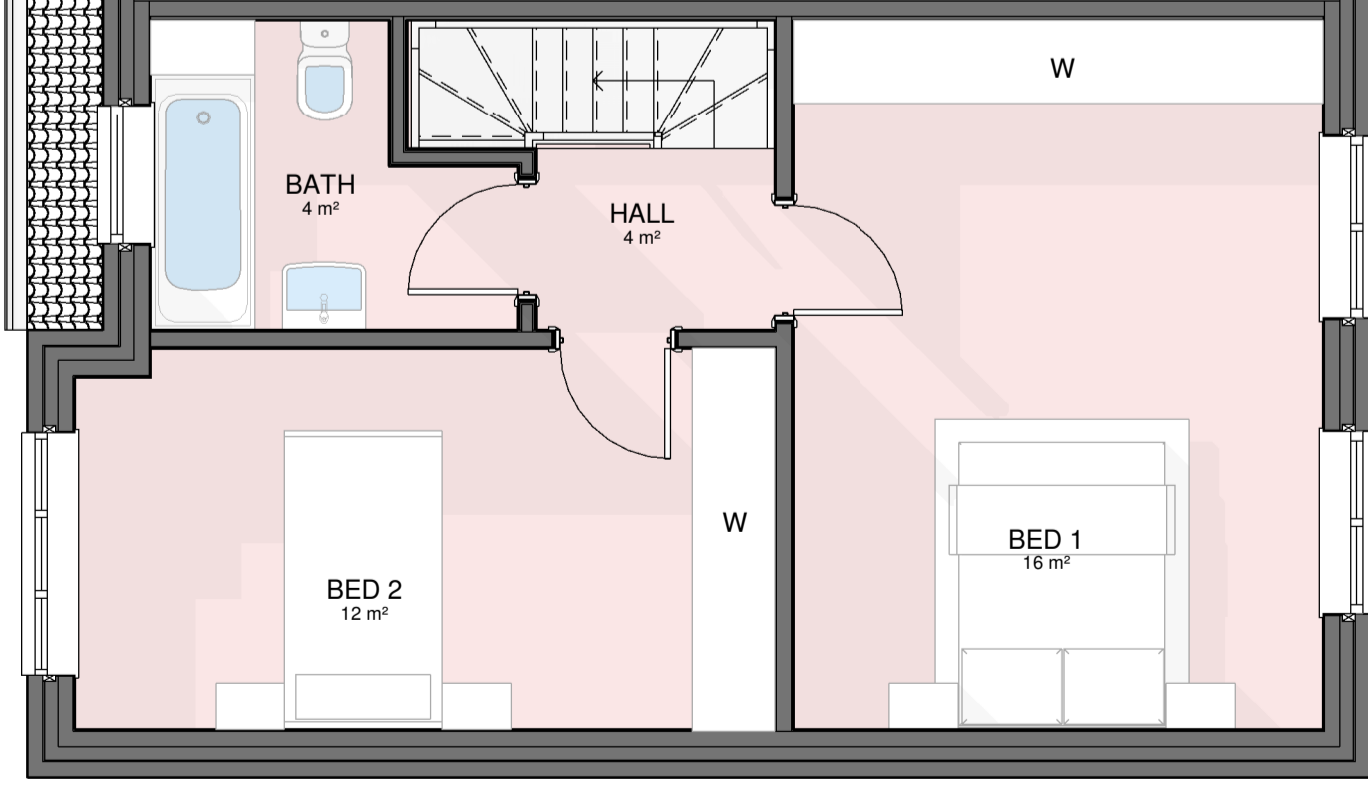

PLOT 1 & 2 - 01 FIRST FLOOR
1 : 50

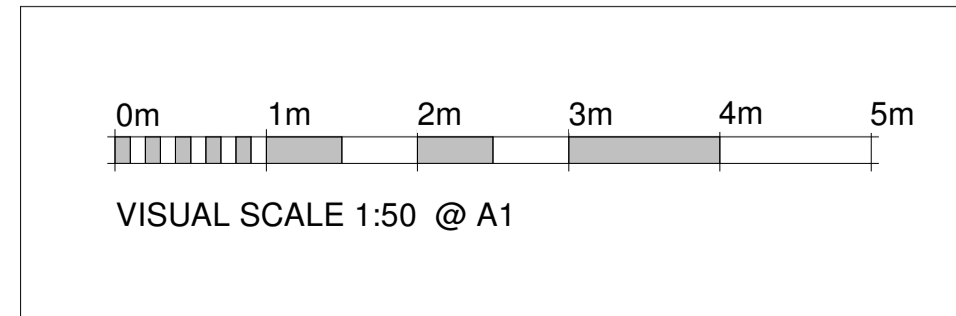

Rev	Description	Date

STATUS: PLANNING
 PURPOSE OF ISSUE: PLANNING

For Enquiries:-
 Khuram - 07878975415
 Anzar - 07495282331
 Email - ak.ids@hotmail.com

PROJECT
 Land at the rear of 1 Highfield Road,
 Bubwith, YO8 6LY

TITLE
 PLOT 1 & 2 - PLANS

CLIENT
 JWK Developments Ltd

DRAWN BY: AM
 CHECKED BY: Checker
 DATE: 14/08/2023

SCALE (@ A1): 1 : 50
 PROJECT NUMBER: 0796

DRAWING NUMBER: A100
 REV: