



# Locomotion Wayfinding Visual and Performance Package 2.1

FOR INFORMATION

13 December 2023

Design that connects us



## About this document

### About this edition:

This edition of the document has been updated to reflect changes following a site visit to Locomotion to see ongoing works and verify sign locations.

Please refer to location plans, schedules and bill of quantities for latest signage information for this site.

For example, Main Hall is now separated out into its own zone to distinguish signage on this building from the urban realm.

The *Wayfinding Visual and Performance Package* introduces the wayfinding sign family for National Railway Museum and Locomotion and provides the detail design intent for each sign product. Location plans shows where these signs are placed at each site, and is supported by a bill of quantities, and signage schedule and culminates in the wayfinding toolkit which gives an overview of signage design assets and principles.

The information provided here offers guidance for construction to ensure the final design is as intended. The sign contractor must review the drawings and details provided here for costing, and once appointed to produce their own fabrication drawings/structural calculations to ensure the final quality, manufacture and installation of signs are as intended by design.

The sign contractor may propose modifications to the design intent and specifications. Where known, these should be raised at interview stage for consideration.

### Disclaimers:

- (i) The visuals shown in this document are for demonstration purposes only, and are not indicative of actual content nor of final production artwork.
- (ii) For quality assurance, no artworking must be done by manufacturers. It is recommended all artwork be carried out by Mima Group to ensure graphics match the approved design intent.
- (iii) Where appropriate, wayfinding design has followed Accessibility & Inclusion best practice guidance, to ensure the final scheme is open for all.
- (iv) Sign types or locations shown are subject to change as sites develop. These have been indicated, where anticipated. Where product types do change, bespoke products would be replaced with a standard sign item, and standard signs will endeavour to be replaced with a similar alternative.

## Contents

Context	4
Sign typology	11
Specifications Intent	16
Quality, Performance and Care	49
Locations Plans	57
Supporting Information	64
Wayfinding Guidelines and Toolkit	70
Appendix	92

## Context

The National Railway Museum and Locomotion aim to inspire the next generation with the past, present and future of the railways.

The *Vision 2025* is on a journey to transform these two museums into inspiring attractions fit for the future, whilst recognising their roles as the cultural heart of their communities –showcasing cutting-edge innovations shaping our world today –alongside the extraordinary birth and growth of the railways –capturing the hearts and minds of the next generation of engineers, innovators and thinkers –and leading the way for regeneration, placemaking and pride in their local regions.

The wayfinding family developed achieves this vision through a coherent and unified scheme that communicates clearly, orients visitors inclusively, and integrates beautifully across these complex historic sites.

Considering the historical context of each site and the transformational masterplan vision, the design scheme created aims to instil local pride celebrating the historical connection of the museum sites to the story of the railways in contemporary ways.

Site analysis

Both museum sites are a true mix of historic and contemporary buildings, working and display engines, and outdoor spaces, and scenic paths. History can not only be found within the collection buildings, but set amongst the sites and along scenic paths, there is something for everyone, and the museums are enjoyed by a vast array of visitor types.

When considering the contribution that these regions have had on the history of the railways, it is clear that local pride in their heritage continues and is enjoyed today.

Unique features from the estates, their industrial heritage and core brand identity are captured in the wayfinding scheme, reflecting the character of museums, their connection to the railways and the Science Museum Group as a whole.



PLACE OF HISTORY



CHARACTERFUL SITES



WORKING ENGINES



CONTEMPORARY ARCHITECTURE



OPEN SPACES



Inspiration

Recognising the unique connection the museum sites have to the story of the railways, and their aim to simultaneously represent this past, present and future.

Taking the notion of *a museum that moves you*, the wayfinding design takes inspiration from the architecture of railways, celebrating the industrial feat of engineering achieved in the areas and their contribution to the railways globally.

The museum brand colour scheme is paired with industrial materials and construction details and finishes – inspired by the railways and promoting STEM –resulting in a wayfinding scheme that connects the transformed museum sites to its historical setting; capturing the spirit of locomotion on rails in a distinctly contemporary and minimalist way.

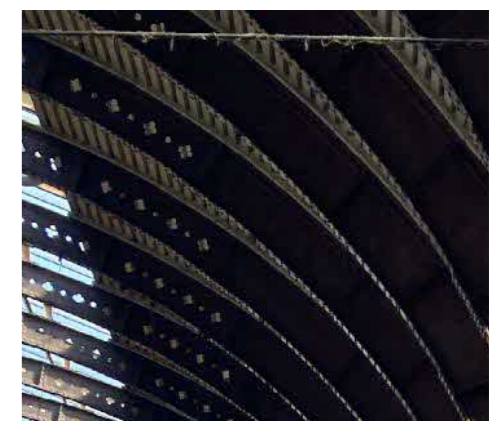

Note : Visuals shown are for demonstrative purposes only, and are not indicative of actual final content.

INDUSTRIAL HERITAGE  
CELEBRATED IN CONTEMPORARY WAY

INSPIRED BY LOCAL  
ARCHITECTURE

INTEGRATES  
BEAUTIFULLY

OPEN  
FOR ALL

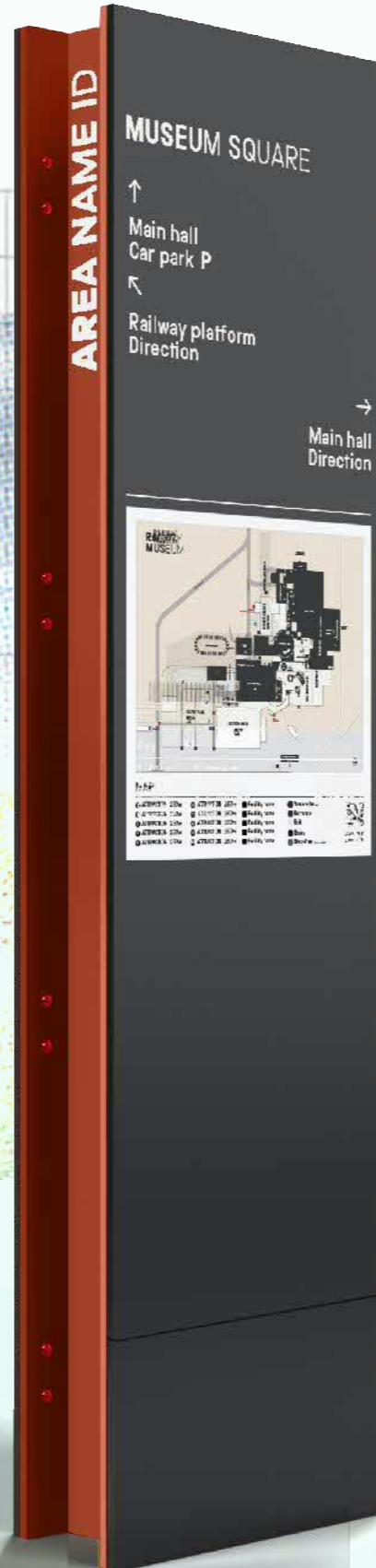

CELEBRATES  
STEM

MINIMAL  
SLEEK YET DURABLE

ENGINEERED  
MATERIALS AND FIXINGS

ONE GROUP  
EXPRESSING BRAND

Product shown : Totem (TOT)

Note : Visuals shown are for demonstrative purposes only,  
and are not indicative of actual final content.

CELEBRATES  
STEM

INTEGRATES  
BEAUTIFULLY

INCLUSIVE  
OPEN FOR ALL

ADAPTABLE  
ALSO IN LECTERN VERSION

DIMENSIONAL  
DURABLE MATERIALITY

MULTISENSORY  
FOR SIGHT AND TOUCH

Product shown : Model map lectern (BES)



Note : Visuals shown are for demonstrative purposes only, and are not indicative of actual final content.

ENGINEERED MATERIALS AND FIXINGS

DISTINCT EXPRESSING VALUE

CELEBRATES STEM

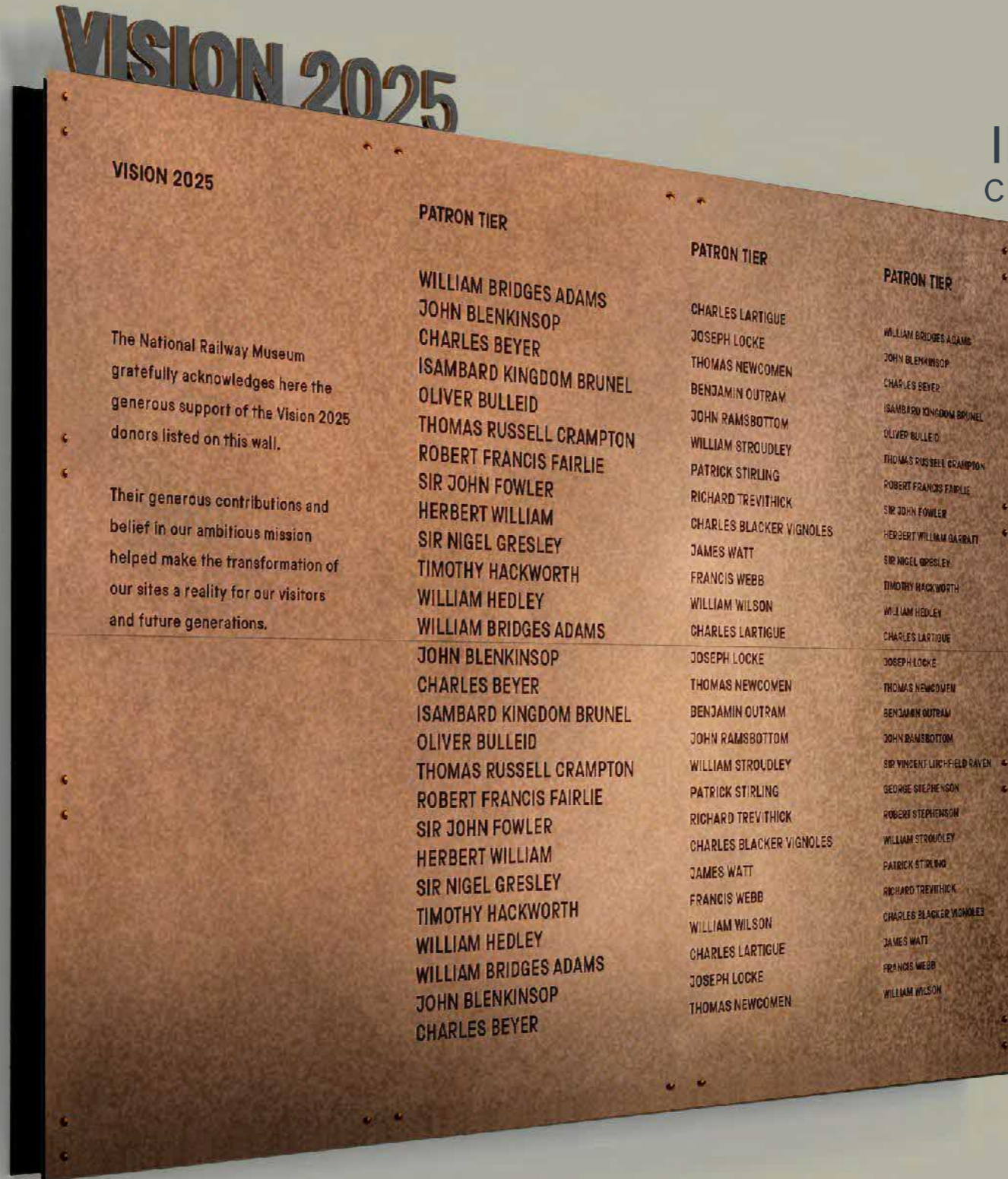

INDUSTRIAL HERITAGE CELEBRATED IN CONTEMPORARY WAY

CONNECTION WITH WAYFINDING

SCULPTURAL EMBOSSED, ROBUST, TACTILE

UPDATED NOTE: Vision 2025 lettering element to be removed from fabricated design

Note : Visuals shown are for demonstrative purposes only,  
and are not indicative of actual final content.



UPDATED NOTE:  
Orientation of museum  
identification is under  
review and may change

Product shown : STH/X/E Stencil IDs Huge /Extra Big /Entry, TOT Totem, VNM Vinyl Midi

## Typology

The wayfinding scheme adopts a 'one-look' approach, to develop across the full typology of sign products required at National Railway Museum and Locomotion.

The following pages show the full range of sign products, splitting them up into the areas they can be found at each museum site, based on the transformation roll-out programme.

# Typology Locomotion

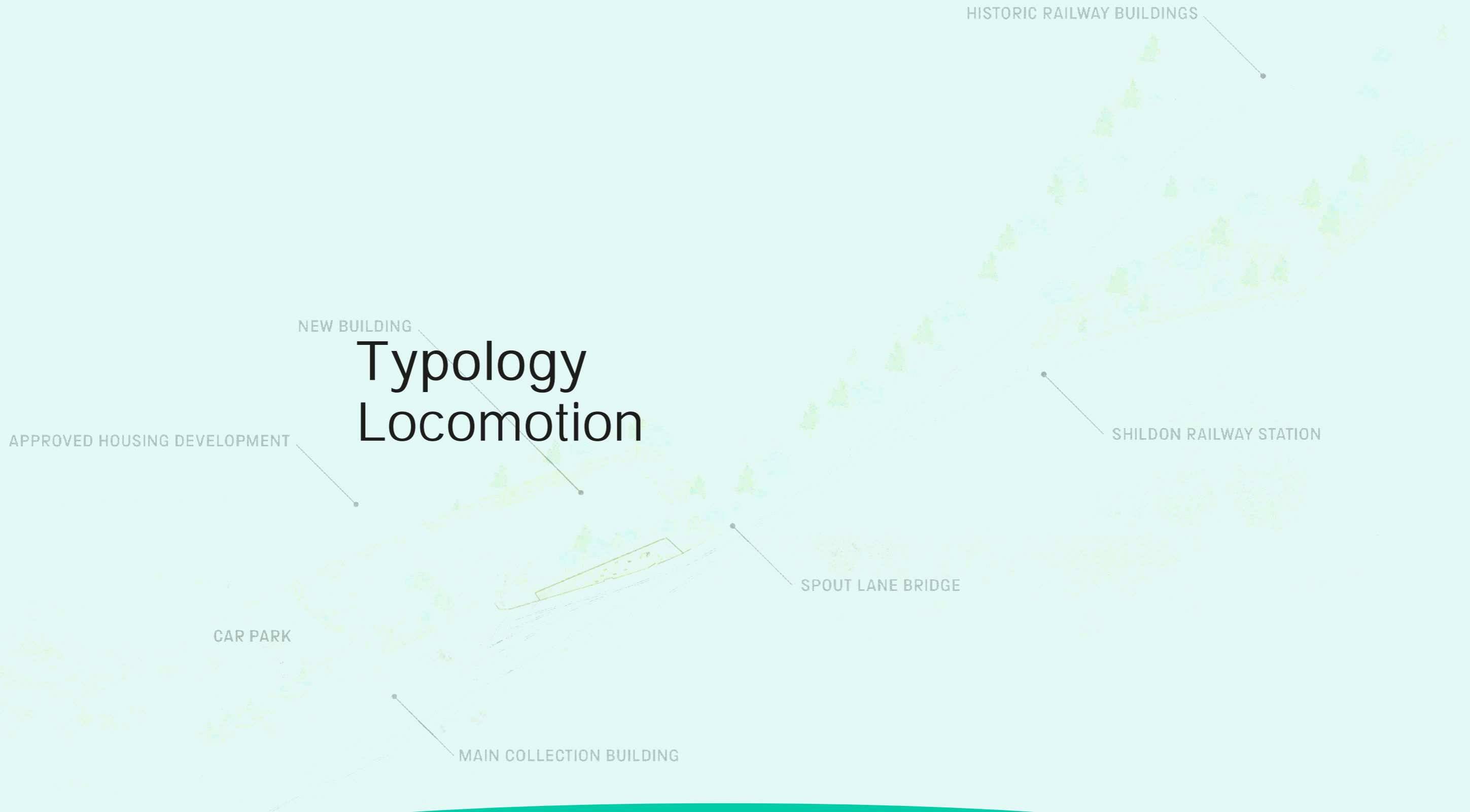

RT SHILDON RAIL TRAIL (LAST MILE)

Introduces passers-by as well as visitors to the museum site, providing a connection between the historic landmarks and collections buildings, via a breadcrumb trail route. The last mile is used by pedestrians, cyclists and vehicles, the wayfinding family here identifies the museum, and landmarks, informs about operational hours, provides and overview of areas of interest within proximity.

- Signage : PNQ/ G Panel (Square/Gate –part of Urban Realm BoQ) | TOT Totem
- Bespoke : STX Stencil Extra Big Museum ID –part of Urban Realm BoQ
- Donor Rec : N/A
- Note: products not within standard wayfinding

Note : Visuals shown are for demonstrative purposes only of signage product scale and placement only, and are not indicative of final content nor architecture.

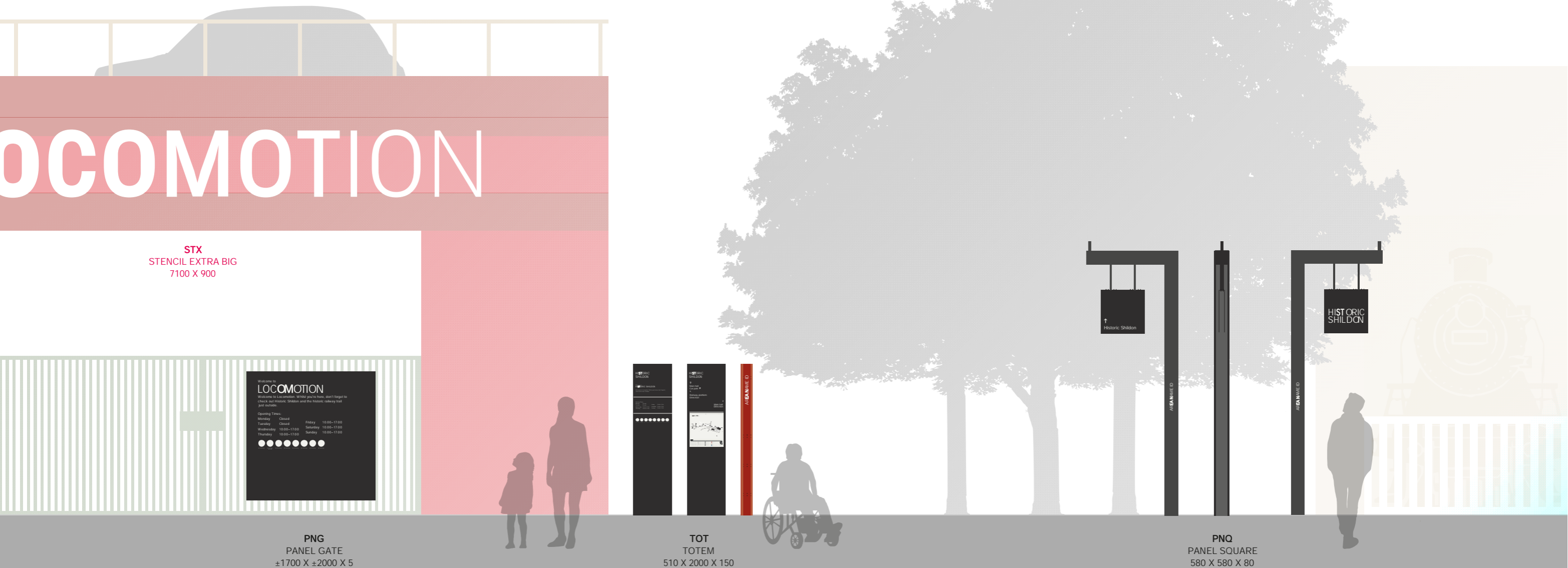

MH MAIN HALL + UR URBAN REALM (INC. PARKING)

A mixed-use space, that focuses on pedestrian priorities, and how best to enjoy attractions safely. The wayfinding family here identifies the museum, collections buildings and attractions, directs to points of interest within proximity, and provides mapping.

**Note :** Visuals shown are for demonstrative purposes only of signage product scale and placement only, and are not indicative of final content nor architecture.

- Signage :** PNS/ L/ G/ Q Panel (Small/Large/Gate/Square) | RDL Road Sign (Large) | STH Stencil (Huge) | TOT Totem
- Bespoke :** BES (Tactile lectern map) | STG/ X Stencil (Gigantic/Extra Big) Museum IDs –see *Shildon Rail Trail*)
- Donor Rec :** N/A
- New items :** B JL (Barrier Jacket) and VNW (Vinyl Window) are not shown. See *SPECIFICATIONS INTENT* for more information.
- Note:** products not within standard wayfinding

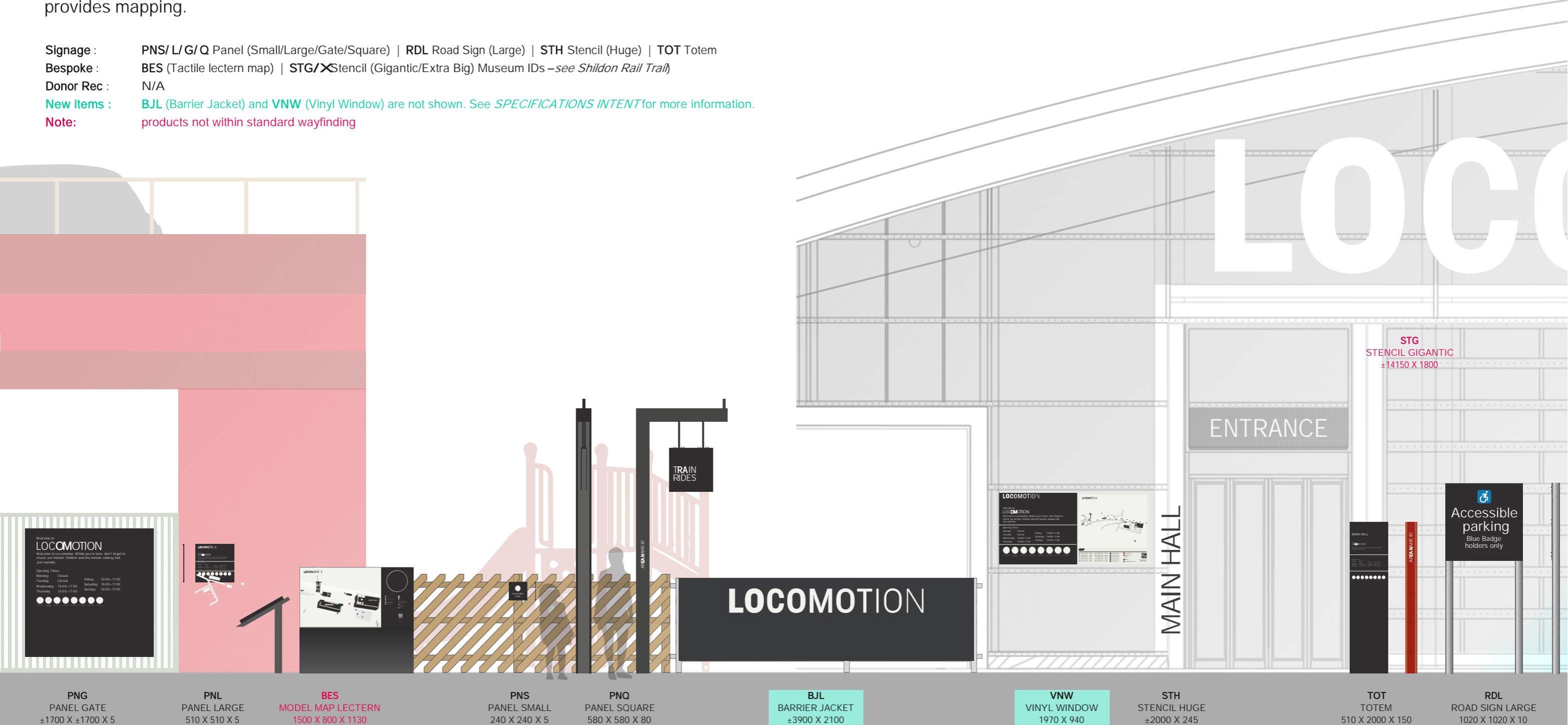

**PNG**  
PANEL GATE  
±1700 X ±1700 X 5

**PNL**  
PANEL LARGE  
510 X 510 X 5

**BES**  
MODEL MAP LECTERN  
1500 X 800 X 1130

**PNS**  
PANEL SMALL  
240 X 240 X 5

**PNQ**  
PANEL SQUARE  
580 X 580 X 80

**BJL**  
BARRIER JACKET  
±3900 X 2100

**VNW**  
VINYL WINDOW  
1970 X 940

**STH**  
STENCIL HUGE  
±2000 X 245

**TOT**  
TOTEM  
510 X 2000 X 150

**RDL**  
ROAD SIGN LARGE  
1020 X 1020 X 10

NH NEW HALL

Continues the wayfinding language seen outside, with an internal product suite, that also mimics the typology seen at NRM. The wayfinding is minimal, with large overhead signage to point towards facilities or exits when walking between the train exhibit aisles, whilst building signage identifies the site to the surrounding area, and hall name by the entrance at for visitors.

- Signage : PNM/ L/ Q/ P/ J Panel (Midi/Large/Square/Picto/Projecting) | STE/H Stencil (Entry/Huge) | TOT Totem | VNM Vinyl (Midi)
- Bespoke : STX Stencil Extra Big Museum ID
- Donor Rec : DNA (Donor Vision 2025 Board) | \*DNX (Project Supporter Acrylic Panel)
- Notes: products shown in red are not within standard wayfinding | \* existing museum product

Note : Visuals shown are for demonstrative purposes only of signage product scale and placement only, and are not indicative of final content nor architecture.

# LOCOMOTION

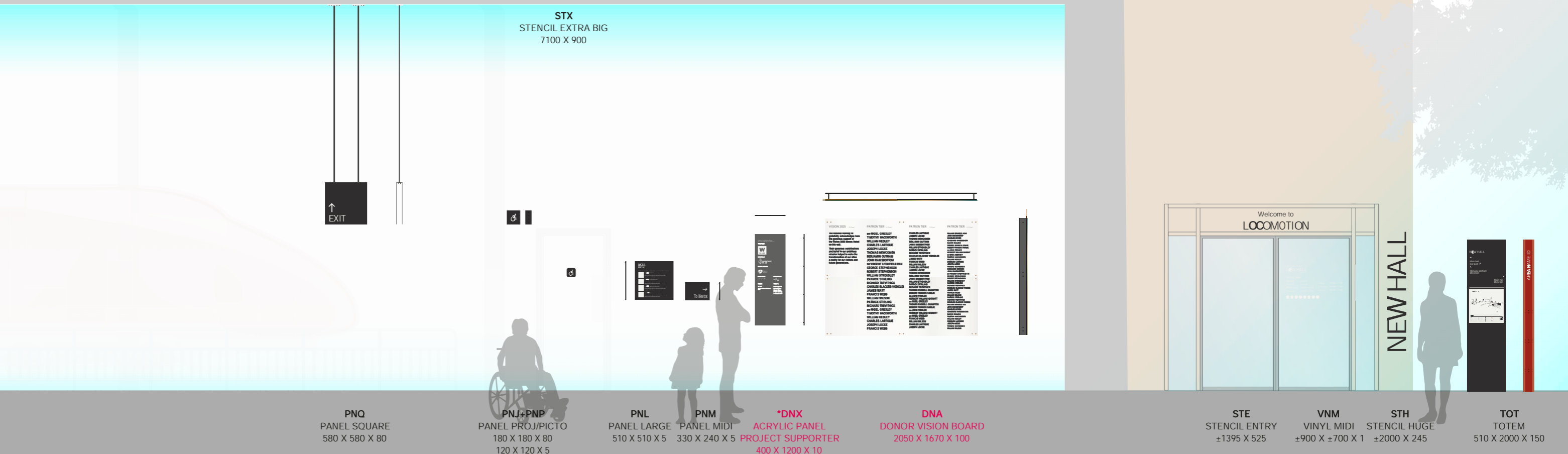

PNQ  
PANEL SQUARE  
580 X 580 X 80

PNJ+PNP  
PANEL PROJ/PICTO  
180 X 180 X 80  
120 X 120 X 5

PNL  
PANEL LARGE  
510 X 510 X 5

PNM  
PANEL MIDI  
330 X 240 X 5

\*DNX  
ACRYLIC PANEL  
PROJECT SUPPORTER  
400 X 1200 X 10

DNA  
DONOR VISION BOARD  
2050 X 1670 X 100

STE  
STENCIL ENTRY  
±1395 X 525

VNM  
VINYL MIDI  
±900 X ±700 X 1

STH  
STENCIL HUGE  
±2000 X 245

TOT  
TOTEM  
510 X 2000 X 150

## Specifications Intent

The following pages describe the design intent for each sign product shown in the sign typology, and provides scale elevation and elevations illustrations for each with annotation. It is the responsibility of the nominated contractor to develop final construction drawings, verifying details following a site survey as various areas become built, and consulting with wayfinding consultant where deviations arise.

lettering and identification

BJL Barrier Jacket

VNM Vinyl Letters Midi

STE Stencil Letters Entry

STH Stencil Letters Huge

STX Stencil Extra Big ID

STG Stencil Gigantic ID

panels

PNJ Panel Projecting

PNP Panel Picto

PNS Panel Small

PNM Panel Midi

PNL Panel Large

PNQ Panel Square

PNG Panel Gate

RDL Road Sign Large

VNW Vinyl for Window

bespoke maps

BES Tactile lectern map

do not recognition

DNA Vision 2025 Board

DNX Project Panel\*

\* to match museum existing acrylic product

posts, markers and totems

TOT Totem





**BJL**

*Barrier jacket*

Identifies museum visitor boundary to replace existing.

**Dimensions :** 3900 x 2100 x 1 mm

**Specifications :** PVC Tightly woven mesh 330gsm with eyelet fixing along bottom  
UV-/water-/wind-resistant.

**Content :** Identification

**Reading range :** ±130 m

**x-Height :** 245 mm

**Character limit :** 10 characters

**Additional:** Barrier jacket to replace existing

**RAL 9003**  
SIGNAL WHITE  
Printed graphics

**RAL 9011**  
GRAPHITE BLACK  
Panel background

ELEVATIONS

SHOWN @ 5% SCALE



ELEVATIONS

SHOWN @ 5% SCALE

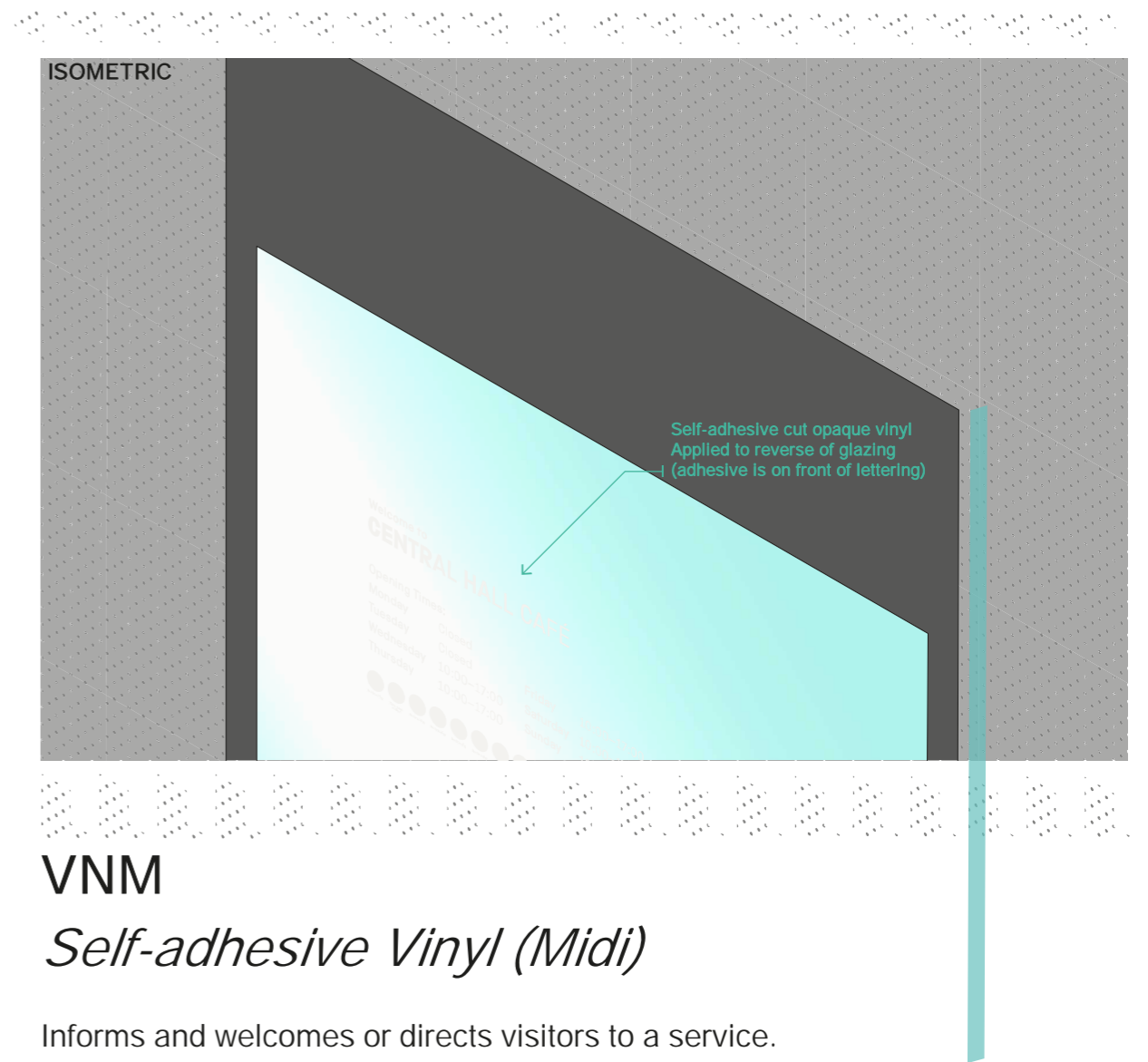

## VNM

### *Self-adhesive Vinyl (Midi)*

Informs and welcomes or directs visitors to a service.

**Dimensions :** 900 x 700 x 1 mm

**Specifications :** Self-adhesive cut vinyl (3M or similar)  
Opaque matt finish (with antiglare/UV/water-resistant coatings ideal)  
Applied to reverse of glass facade

**Content :** Direction, Identification, Information

**Reading range :** 1.5-14 m

**x-Height :** 3.75, 15, 30 mm

**Pictogram :** 45 mm

**Character limit :** 20-45 characters per line (2-10 lines dependent on content)  
OR 25 character per statutory

**Additional:** Primary typesetting  
Applied to reverse of glass facade at 1.2-1.5m above F/L

**RAL 9003**  
SIGNAL WHITE  
Lettering  
Matt opaque finish



ELEVATIONS

SHOWN @ 5% SCALE

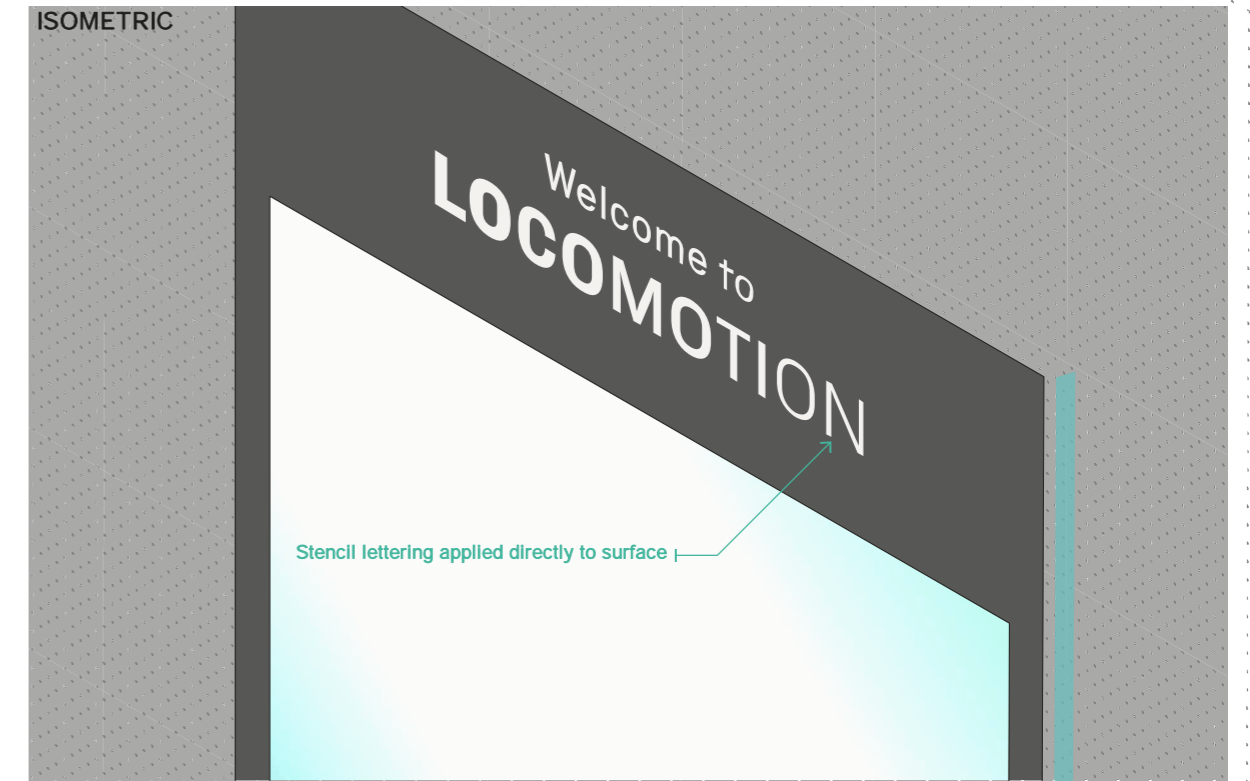

STE  
*Stencil Entry*

Welcome visitors through main entrances.

**Dimensions :** 1395/2150 x 525 mm  
**Specifications :** Painted stencil lettering, exterior paint to suit surface substrate  
Applied horizontally centred above entrance

**Content :** Identification, Information  
**Reading range :** 20–35 m  
**x-Height :** 45 , 75 mm  
**Character limit :** 10 and 25 characters over x2 lines (dependent on content)  
OR 25 character per statutory

**Additional:** Primary typesetting  
Applied above visitor entrance  
1395 width for New Hall only

**Note:** See artwork for final colour, to be determined by wall surface colour

**RAL 9003**  
SIGNAL WHITE  
Lettering colour  
dependent on wall

**RAL 9011**  
GRAPHITE BLACK  
Lettering colour  
dependent on wall

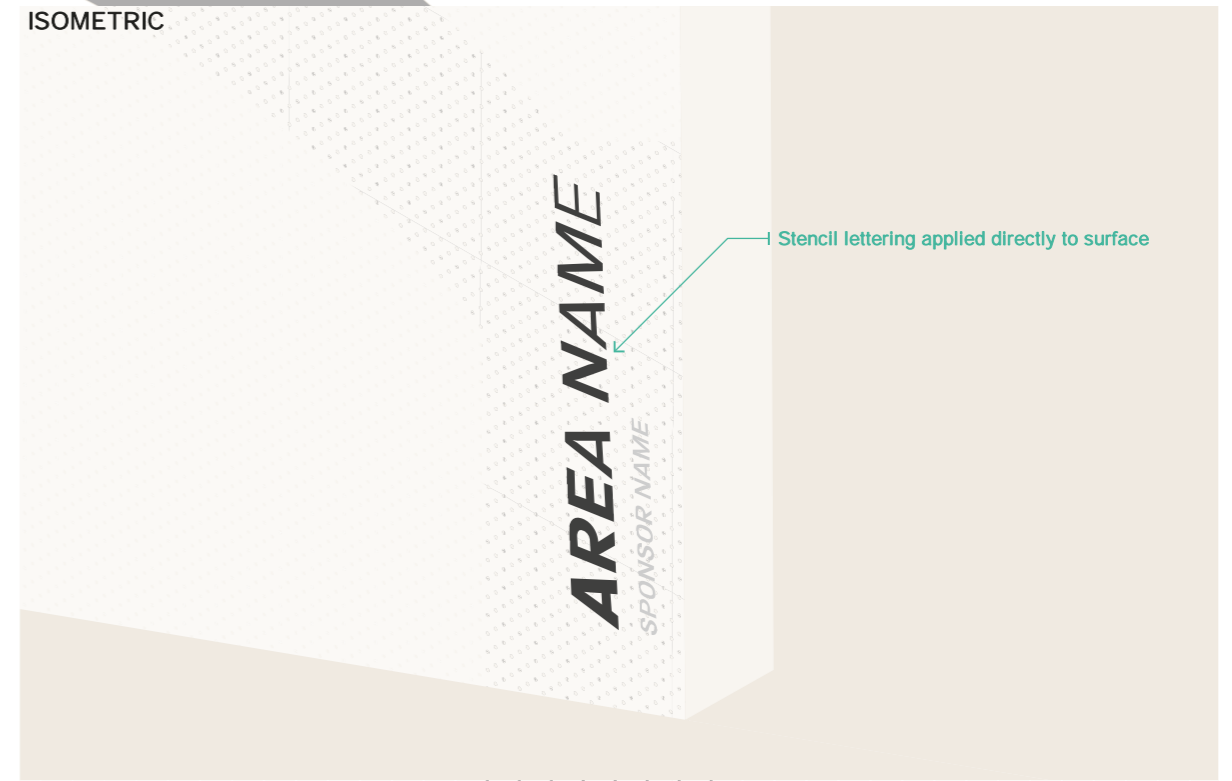
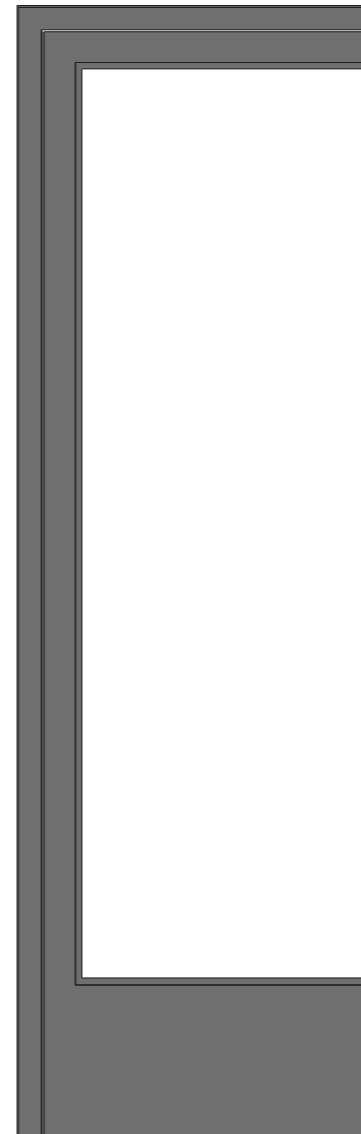
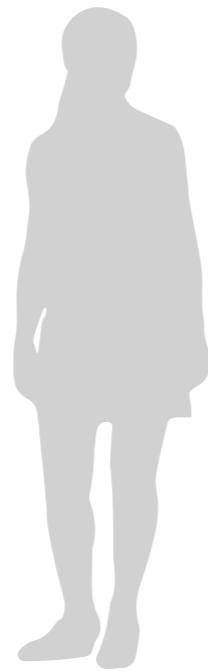

**STH**  
*Stencil (Huge)*

Identify gallery/collection halls.

**Dimensions :** ±2000 x 245 mm  
**Specifications :** Painted stencil lettering, masonry paint to suit surface substrate  
 Stencil to face entrance (read from the ground upwards)  
 Applied at 0.5 m above F/L and ideally 0.5 m away from entrance

**Content :** Identification  
**Reading range :** 78 m  
**x-Height :** 175 mm (245 mm CAP)  
**Character limit :** 15 characters per line (up to x2 lines bottom aligned)  
**Additional:** Signature typesetting  
 Vertical alignment to be read from the ground upwards  
 Baseline to face entrance and applied at 0.5m above F/L and from entrance

**Note:** See artwork for final colour, to be determined by wall surface

**RAL 9003**  
SIGNAL WHITE  
Lettering colour  
dependent on wall

**RAL 9011**  
GRAPHITE BLACK  
Lettering colour  
dependent on wall

ELEVATIONS

SHOWN @ 5% SCALE



VISUAL

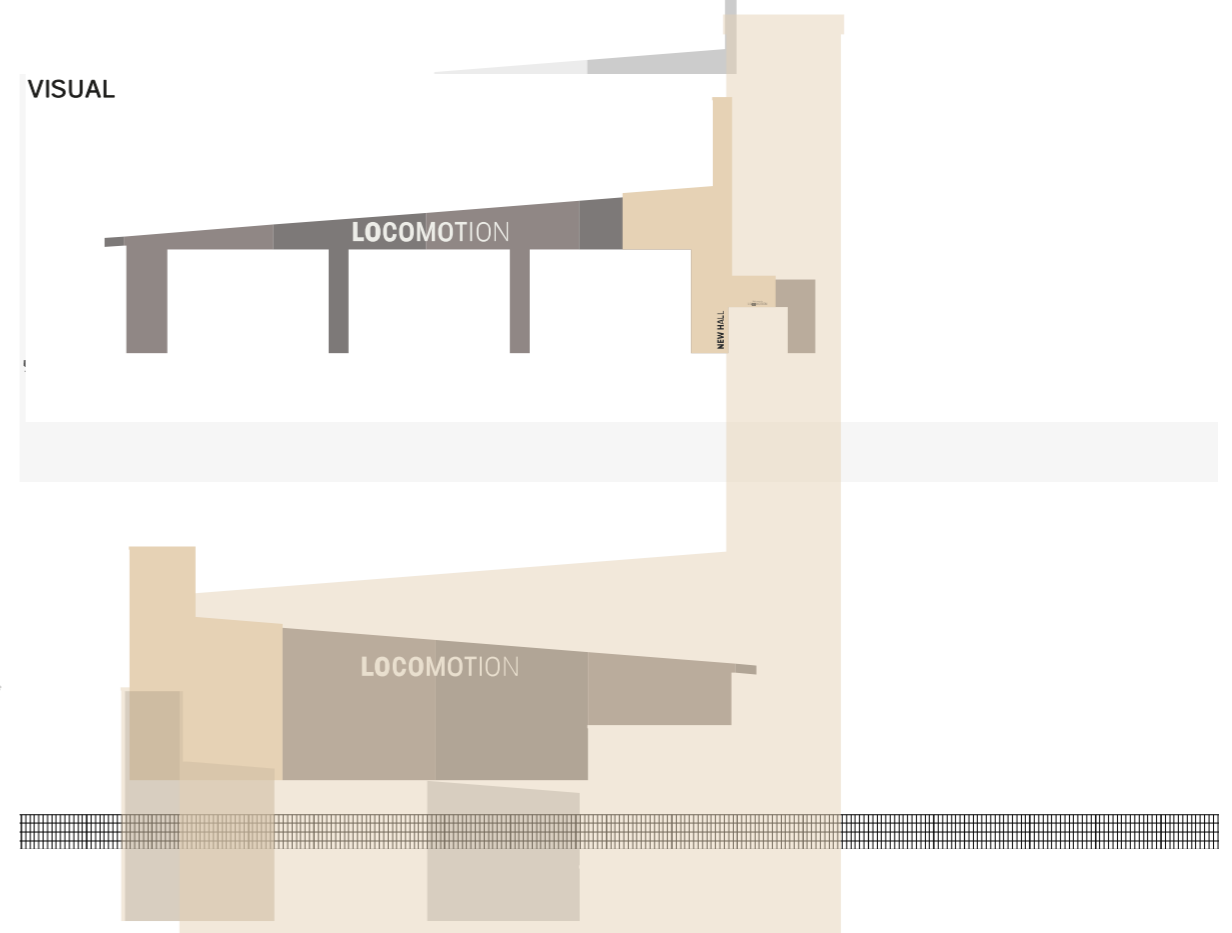

STX

*Stencil Extra Big –Museum ID*

Identifies Locomotion museum arrival entrance or new collection building.

**Dimensions :** 7100 x 900 mm

**Specifications :** Painted stencil lettering on bridge masonry or building kingspan facade  
Stencil to be centred on facade at high level  
Opaque matt finish (with antiglare/UV/water-resistant coatings ideal)

**Content :** Identification

**Reading range :** 250+ m

**x-Height :** 642.5 mm (900 mm CAP)

**Character limit :** 10 characters (museum logo)

**Additional:** Landscape orientation (see Appendix: museum identification for placement elevations)

**Note:** Application to be determined by exterior facade or ground surface  
Final artwork for stencil to be opaque white

**RAL 9003**  
SIGNAL WHITE  
Lettering colour

ELEVATIONS

SHOWN @ 1.75% SCALE

LOGO SHOWN IN BLACK FOR DEMONSTRATIVE PURPOSES ONLY  
ARTWORK COLOUR TO BE OPAQUE WHITE

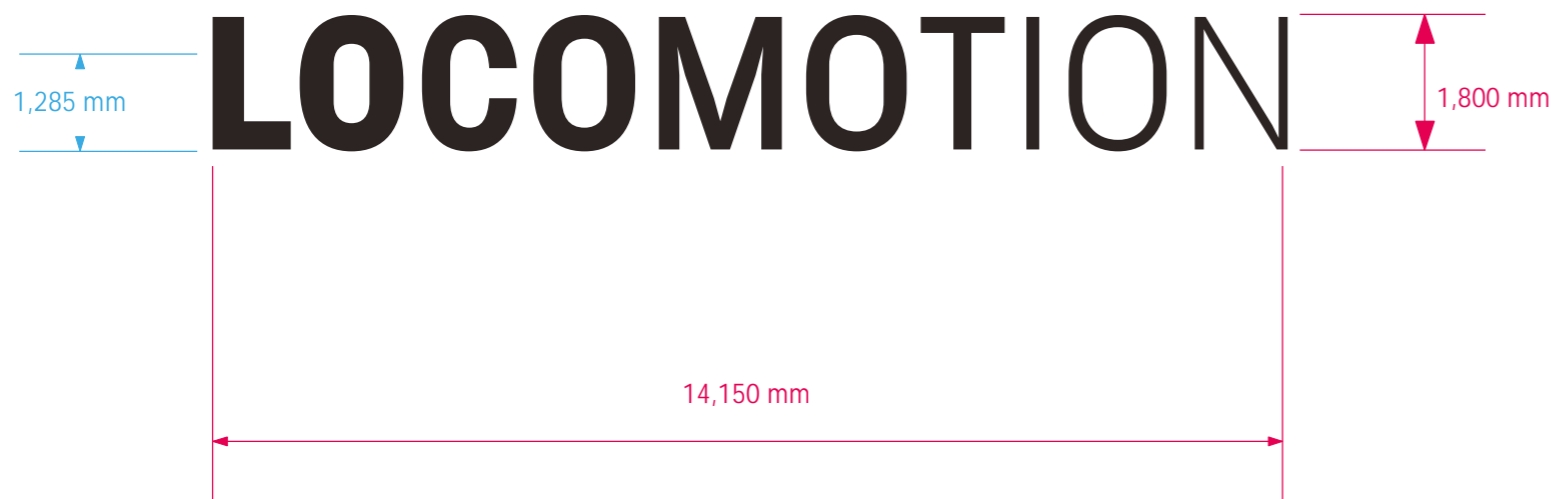

SHOWN @ 1% SCALE

ARTWORK COLOUR TO BE OPAQUE WHITE



### STG

#### *Stencil Gigantic – Museum ID*

Identifies existing Locomotion collection building.

**Dimensions :** ±14150 x 1800 mm

**Specifications :** Painted or Cut vinyl stencil lettering on glass and clad façades

Stencil to be centred on facade at high level

Opaque matt finish (with antiglare/UV-water-resistant coatings ideal)

**Content :** Identification

**Reading range :** 500+ m

**x-Height :** 1285 mm (1800 mm CAP)

**Character limit :** 10 characters (museum logo)

**Additional:** Landscape orientation

Horizontally centred on facade at high level

**Note:** Application to be determined by facade surface, with vinyls recommended to be applied on reverse of any glass facade  
Final artwork for stencil to be opaque white

**RAL 9003**  
SIGNAL WHITE  
Lettering colour

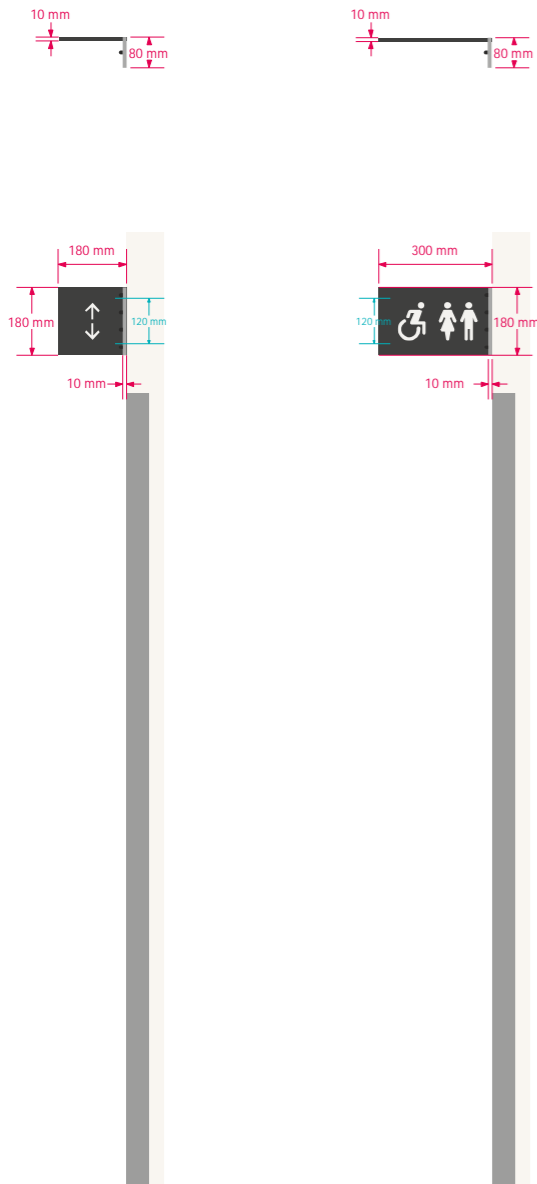

ISOMETRIC



PNJ

*Panel (Projecting)*

Identify facilities, mounted perpendicularly above entrance.

**Dimensions :** 180/300/420 x 180 x 80 mm

**Specifications :** 5mm folded aluminium panels with matt powdercoat finish including edges  
Printed graphics and eased roundover edges  
Coach bolt and washer fixing to suit wall substrate (colour matched to panel)

**Content :** Identification

**Reading range :** 50 m

**Pictogram :** 120 mm

**Character limit :** N/A (pictograms only)

**Additional:** Mounted perpendicular to wall at ±2.4 m above F/L on left side of door  
With varies dependent on number of pictograms

**RAL 9003**  
SIGNAL WHITE  
Printed graphics

**RAL 9011**  
GRAPHITE BLACK  
Panel background and  
fixings

ELEVATIONS

SHOWN @ 5% SCALE

PNJ

*General assembly*

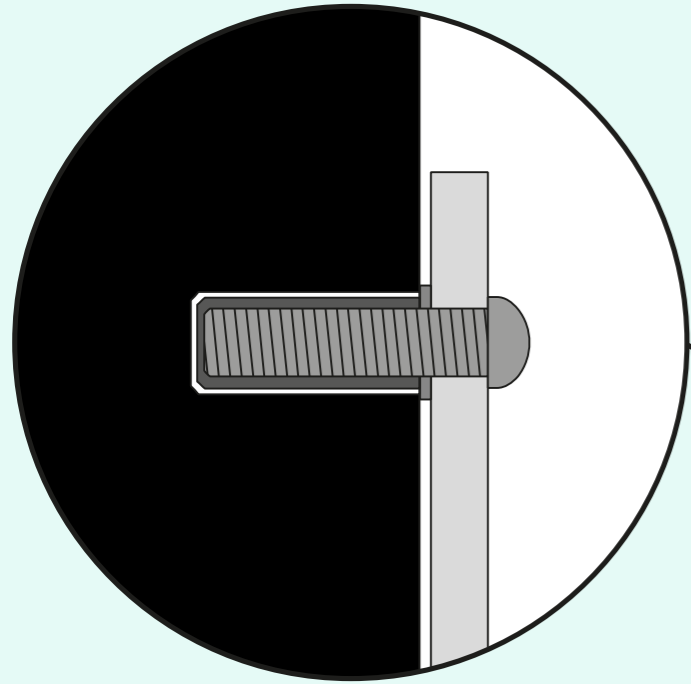

Coach bolt fixed into wall.  
Fixing type to suit mounting surface

Mounted perpendicular to  
wall surface beside doorway

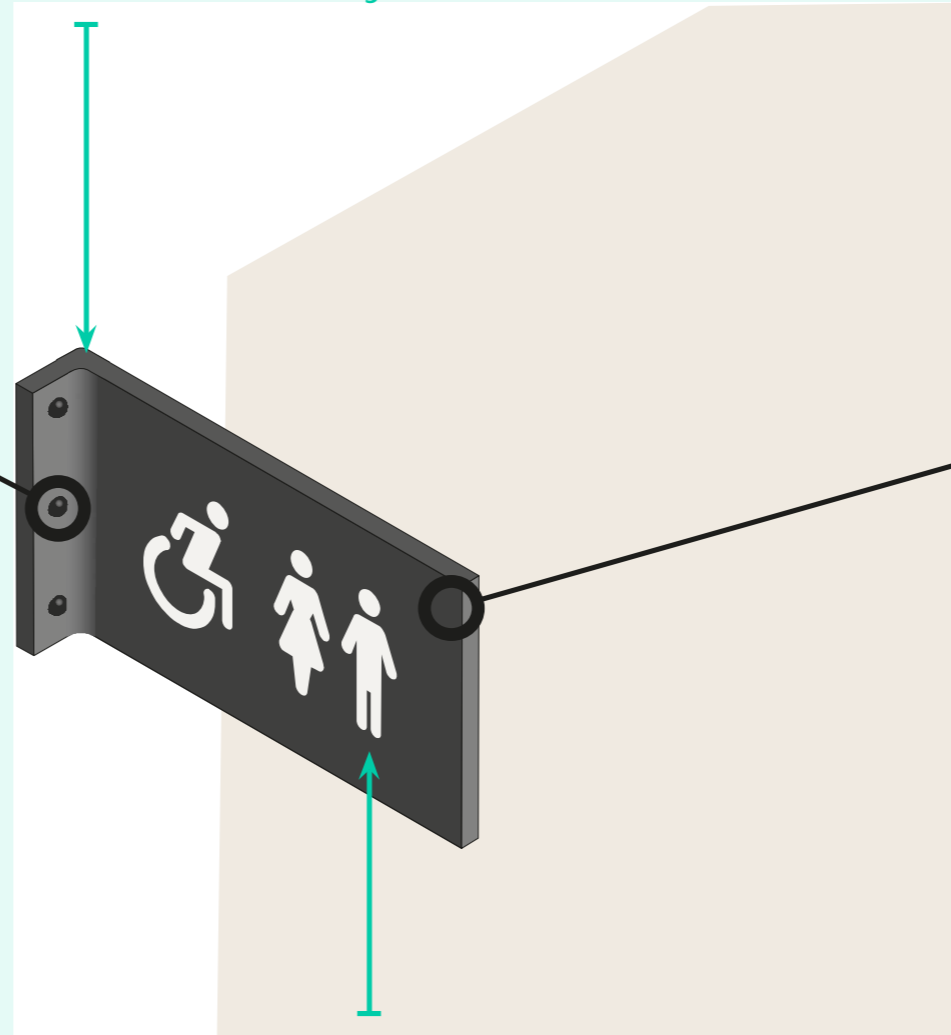

Graphics printed  
direct to media

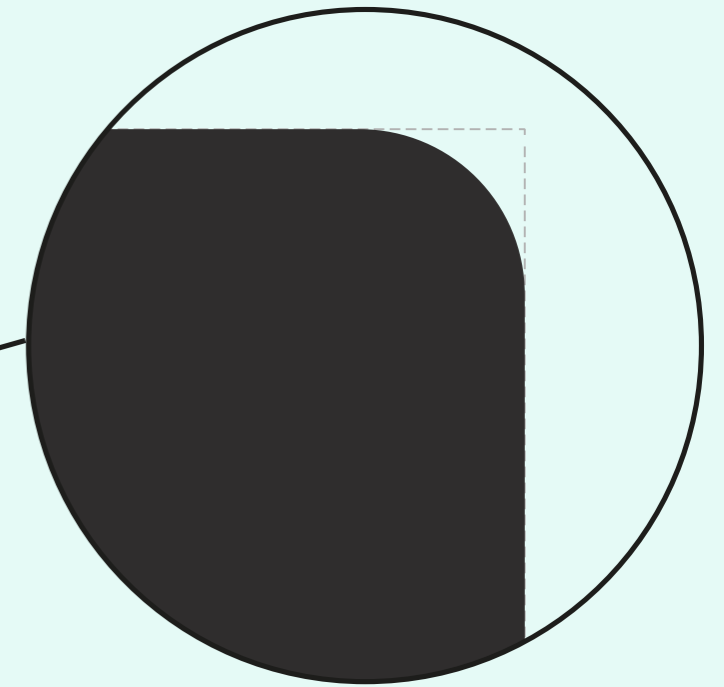

Eased roundover edge profile



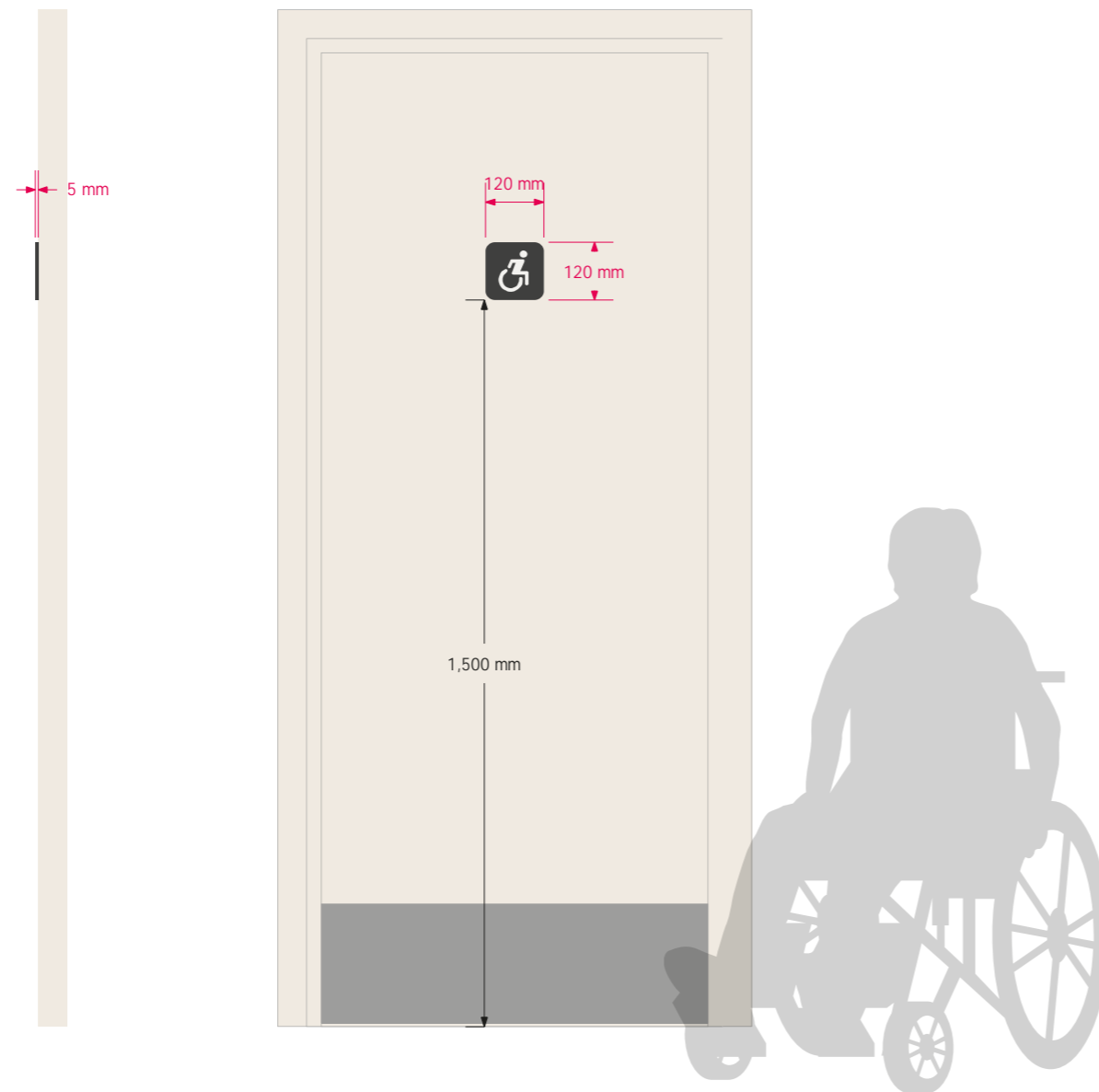

ISOMETRIC



**PNP**  
*Panel (Picto)*

Identify facilities, typically applied to door.

- Dimensions :** 120 x 120 x 5 mm
- Specifications :** Aluminium panel with rounded corners  
Matt powdercoat finish including to edges  
Stencilled graphics and eased roundover edges  
3M adhesive bond backing (or similar) to suit surface substrate

- Content :** Identification
- Reading range :** 50 m
- Pictogram :** 120 mm
- Character limit :** N/A (pictograms only)
- Additional:** Centred on door at 1.5 m above F/L

**RAL 9003**  
SIGNAL WHITE  
Printed graphics

**RAL 9011**  
GRAPHITE BLACK  
Panel background

ELEVATIONS

SHOWN @ 7.5% SCALE

PNP  
*General assembly*

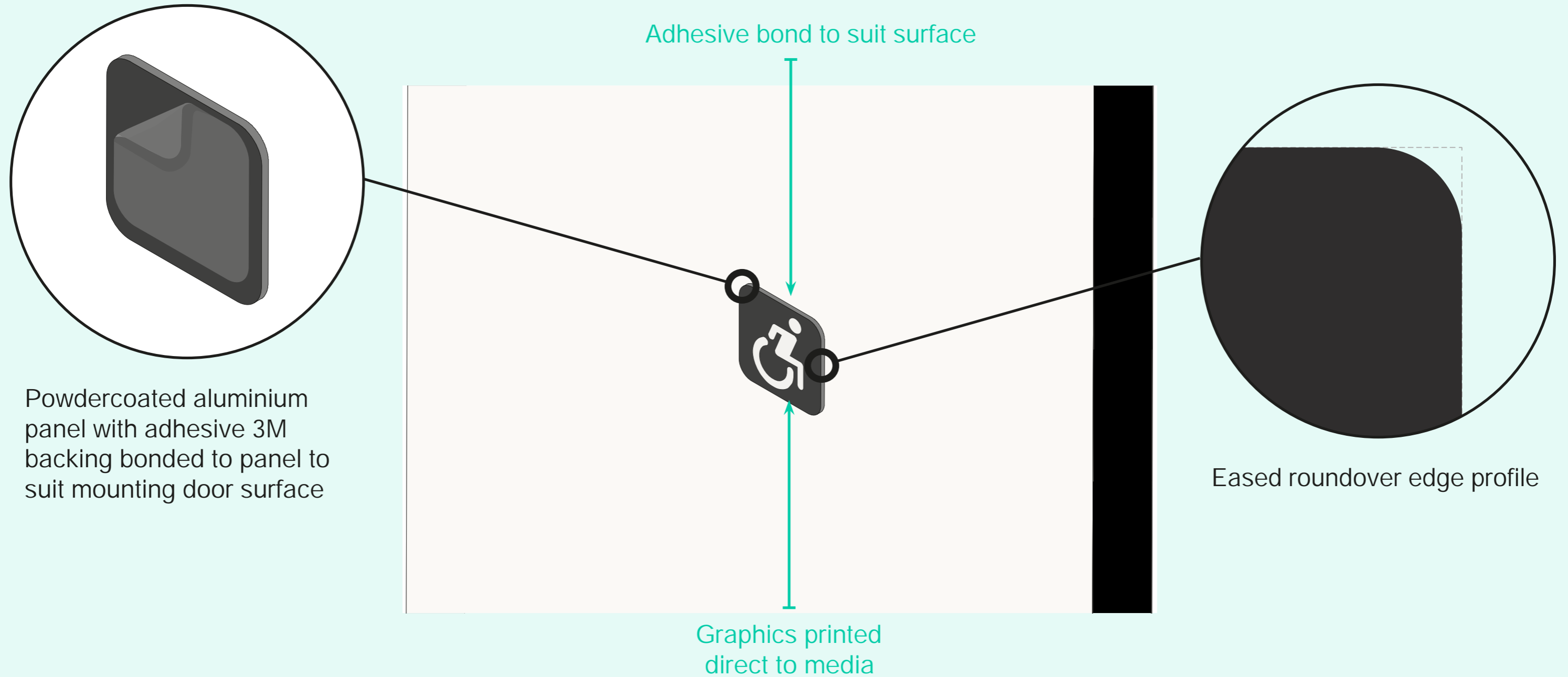

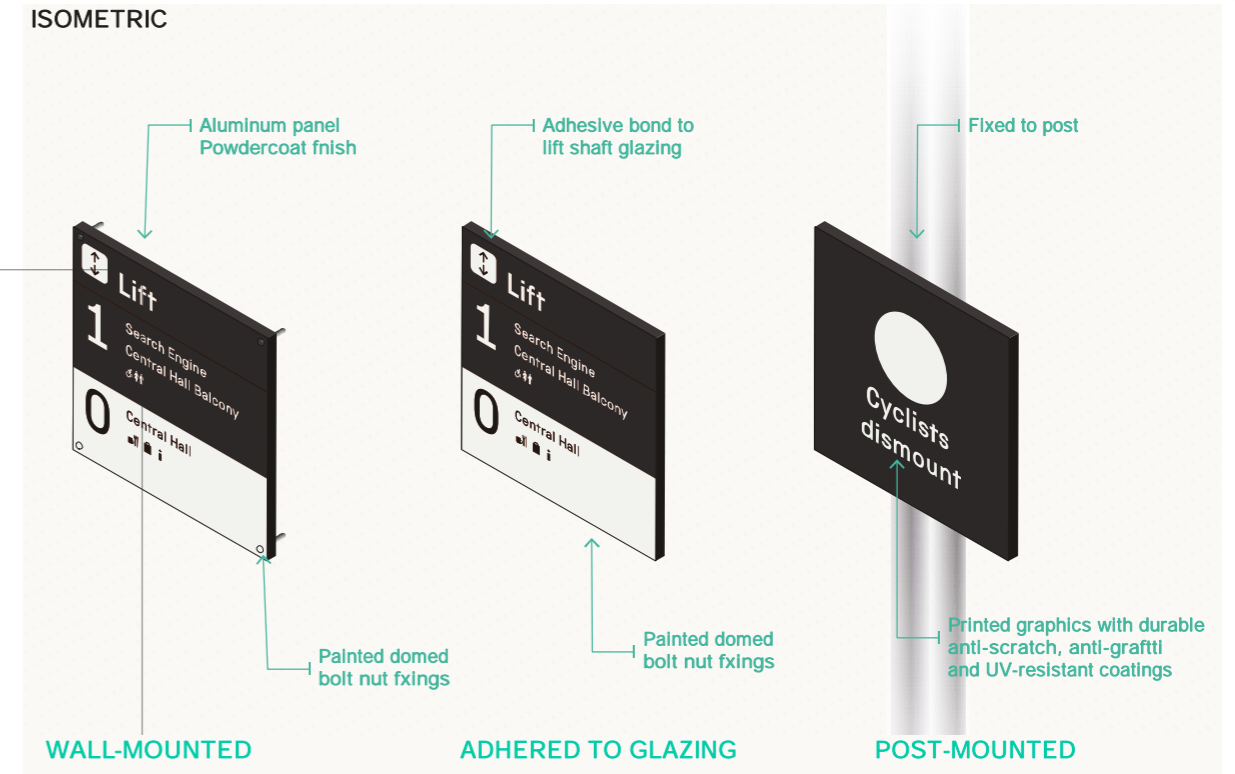
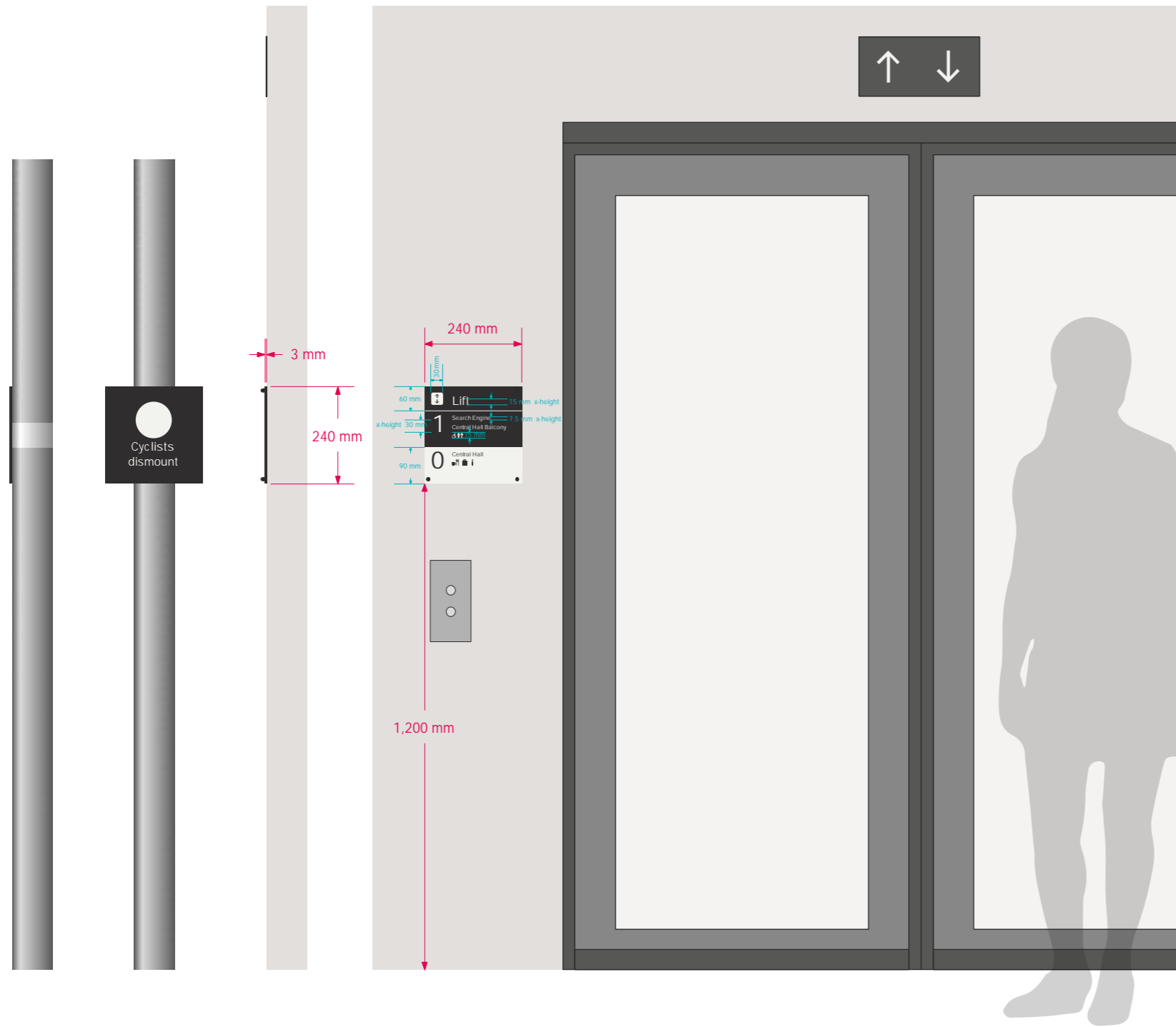

## PNS Panel (Small)

Provide information in open spaces. Suitable for internal or external use on doors, walls, posts and fencing.

- Dimensions :** 240 x 240 x 5 mm  
**Specifications :** Aluminium panels with matt powdercoat finish including eased roundover edges  
 Printed graphics and 1-2 mm raised lettering for floor directories  
 Fixings colour matched to panel, and method to suit mounting surface (glazing/wall/post)  
 Antiglare, UV-water-resistant, Anti-scratch coatings ideal

- Content :** Identification, Information, Statutory  
**Reading range :** 2.5-14 m  
**x-Height :** 5, 7.5, 15, 30 mm  
**Pictogram :** 7.5, 22.5, 45, 120 mm  
**Character limit :** 15-20 characters per line, (up to 6 lines) OR 25 character per statutory  
**Additional:** Primary typesetting  
 Mounted at 1.5m above F/L

- RAL 9003**  
SIGNAL WHITE  
Printed graphics
- RAL 9011**  
GRAPHITE BLACK  
Panel background

ELEVATIONS  
SHOWN @ 7.5% SCALE

PNS

*General assembly*

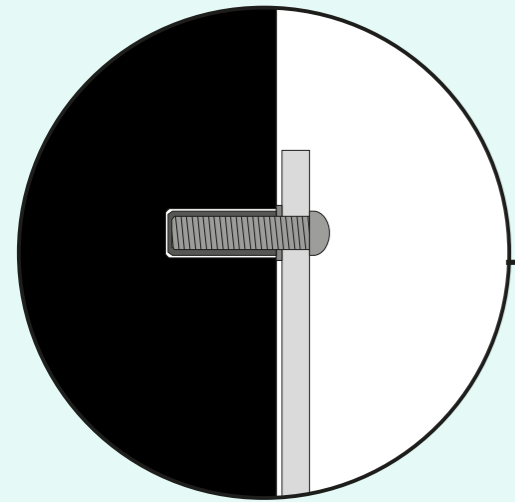

Fixing method to suit mounting surface  
 Fixed to wall using exposed coach bolts  
 OR  
 Fixed to post using standard mount fixing fitted to channel bracket welded on panel rear  
 OR  
 Applied to glazing with adhesive bond on panel rear

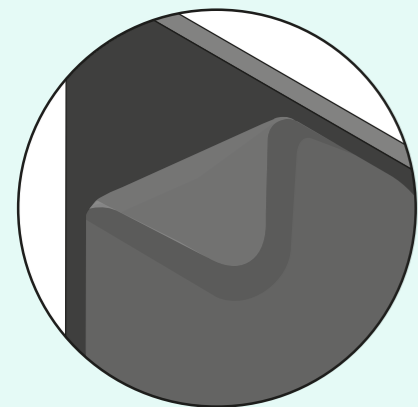

Protective coatings ideal  
 (Anti-glare/ scratch/ graffiti,  
 UV/ Water-resistant)

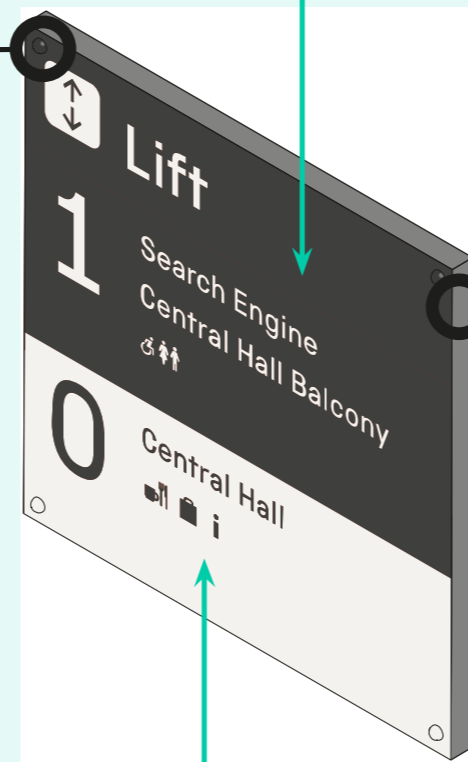

1-2mm Raised lettering for  
 lifts/directories

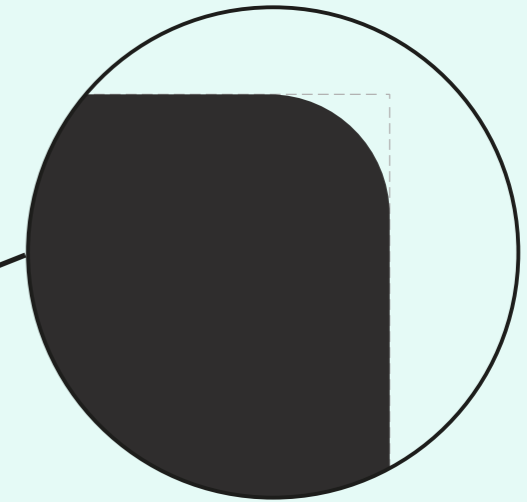

Eased roundover edge profile

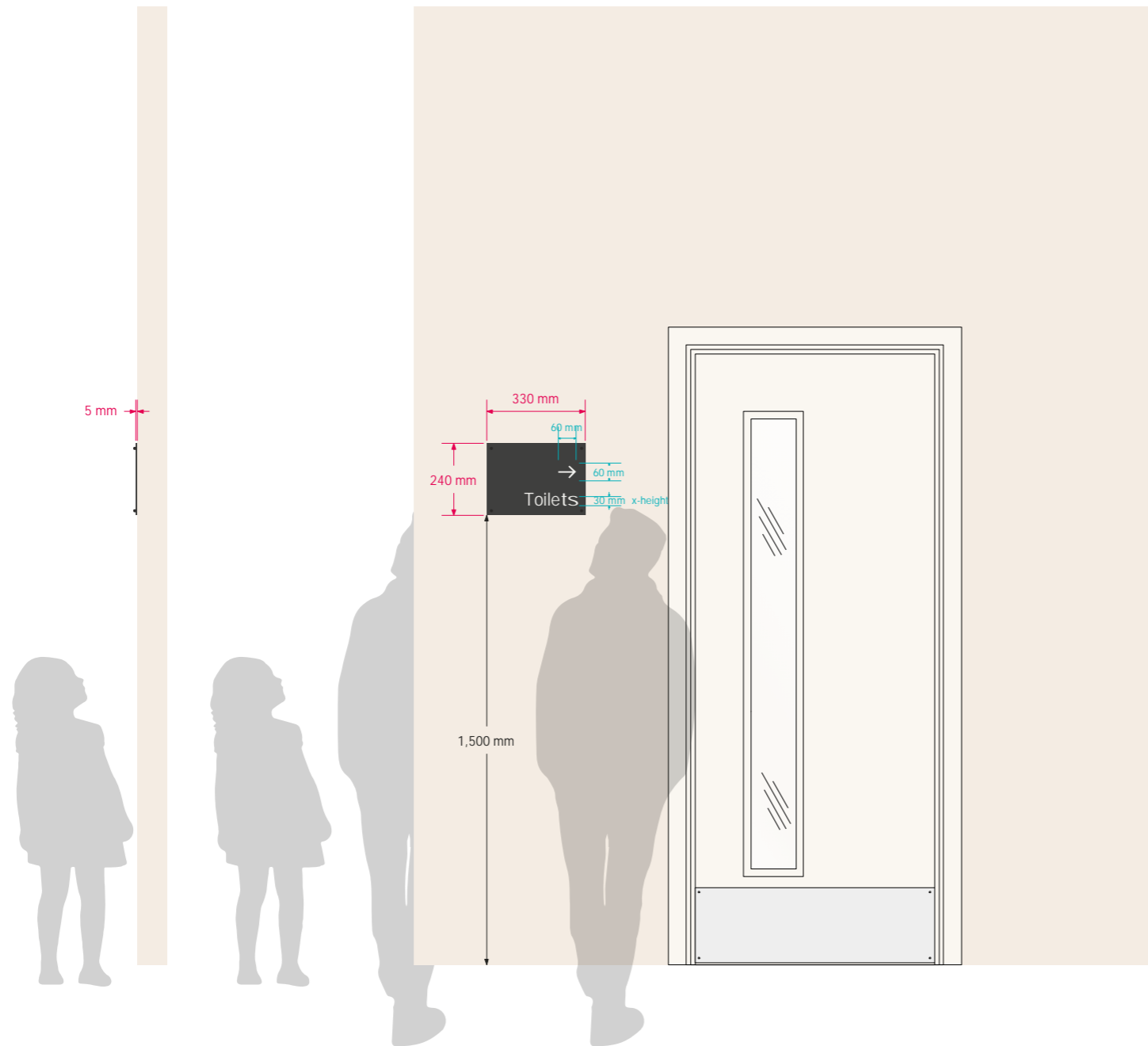

ISOMETRIC



**PNM**  
*Panel (Midi)*

Identify a service or provide directions, ideal along aisles and corridors.  
Mounted on to walls.

- Dimensions :** 330 x 240 x 5 mm
- Specifications :** 5mm aluminium panels with matt powdercoat finish including edges  
OR printed dibond panel with black core and sealed edges  
Printed graphics and eased roundover edges  
Colour-matched coach bolt fixings to suit mounting wall surface

- Content :** Direction, Identification, Information
- Reading range :** 3.5-14 m
- x-Height :** 7.5 , 15 , 30 mm
- Pictogram :** 22.5, 45 , 60 mm
- Character limit :** 10-15 characters per line (2-3 lines max)
- Additional:** Primary typesetting  
Mounted at 1.5-1.8m above F/L

**RAL 9003**  
SIGNAL WHITE  
Printed graphics

**RAL 9011**  
GRAPHITE BLACK  
Panel background

ELEVATIONS

SHOWN @ 5% SCALE

PNM

*General assembly*

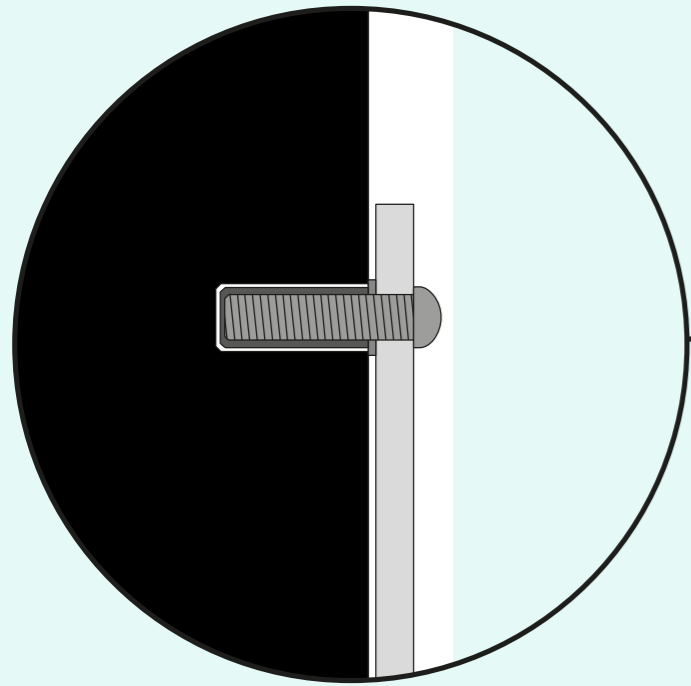

Fixing method to suit mounting surface  
Fixed to wall using exposed coach bolts

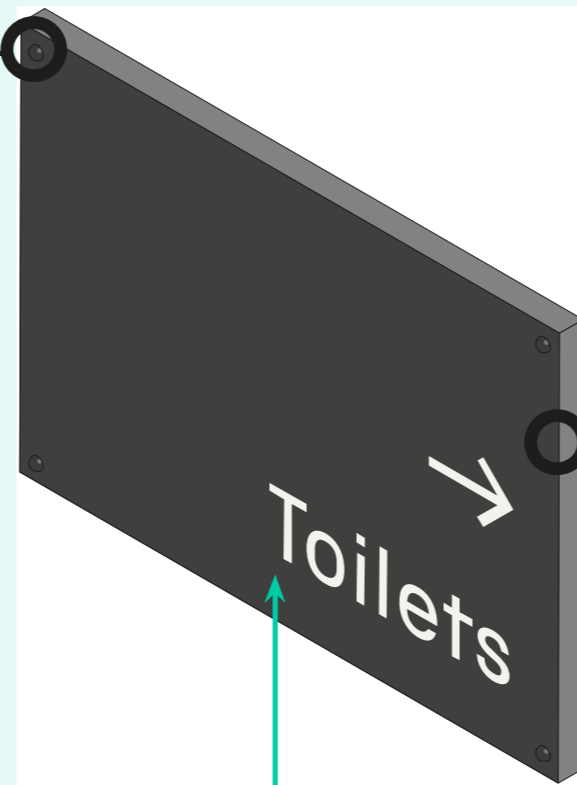

Graphics printed  
direct to media

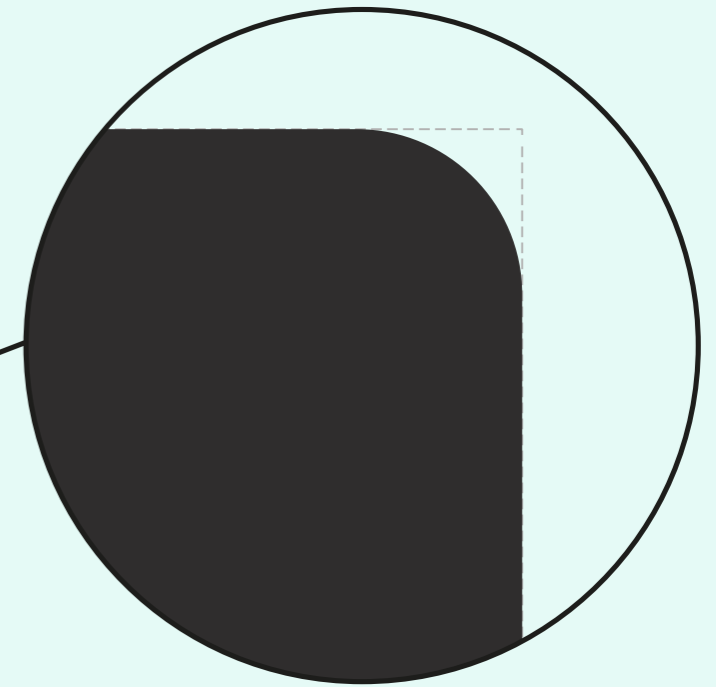

Eased roundover edge profile

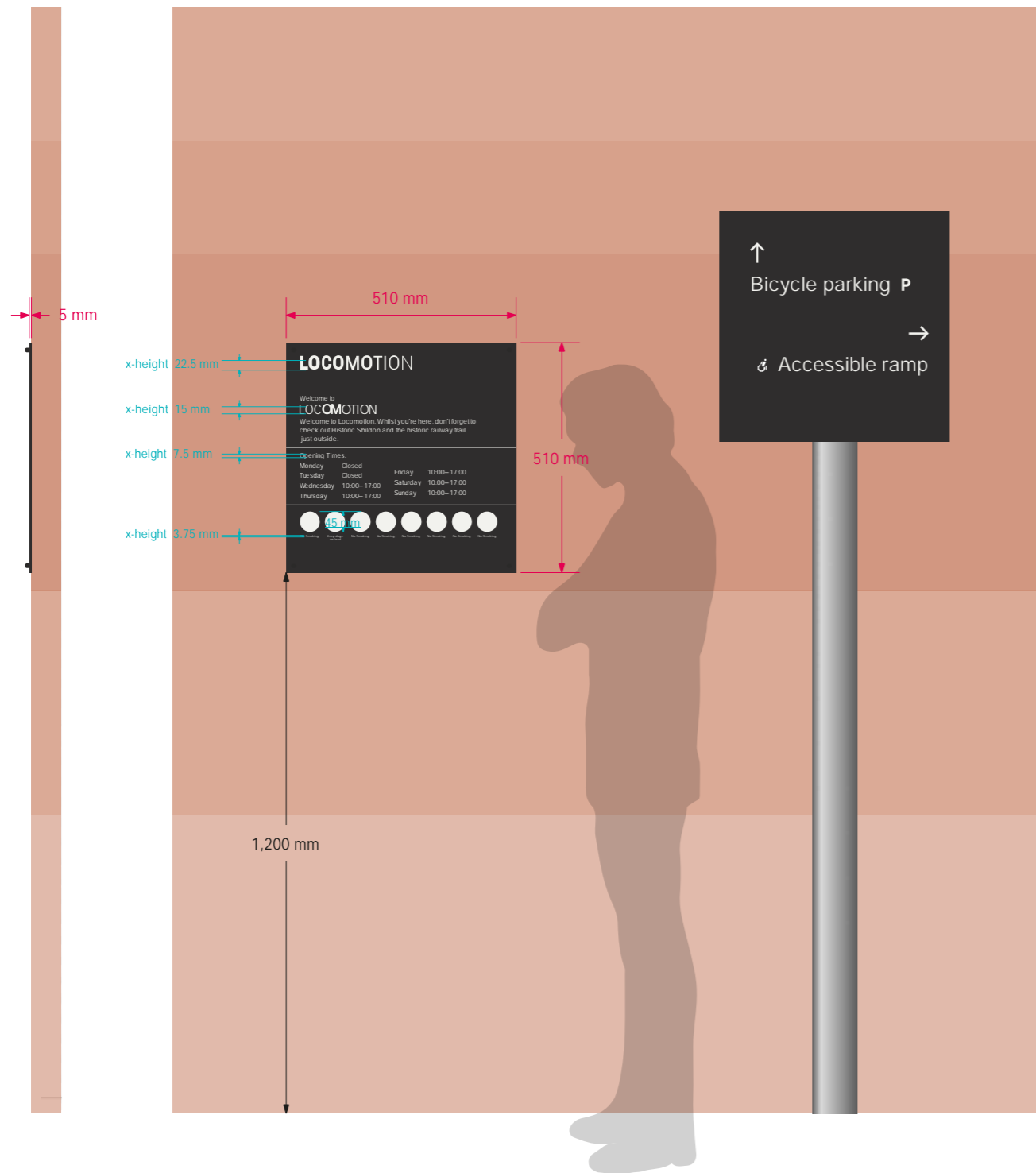

ELEVATIONS

SHOWN @ 7.5% SCALE

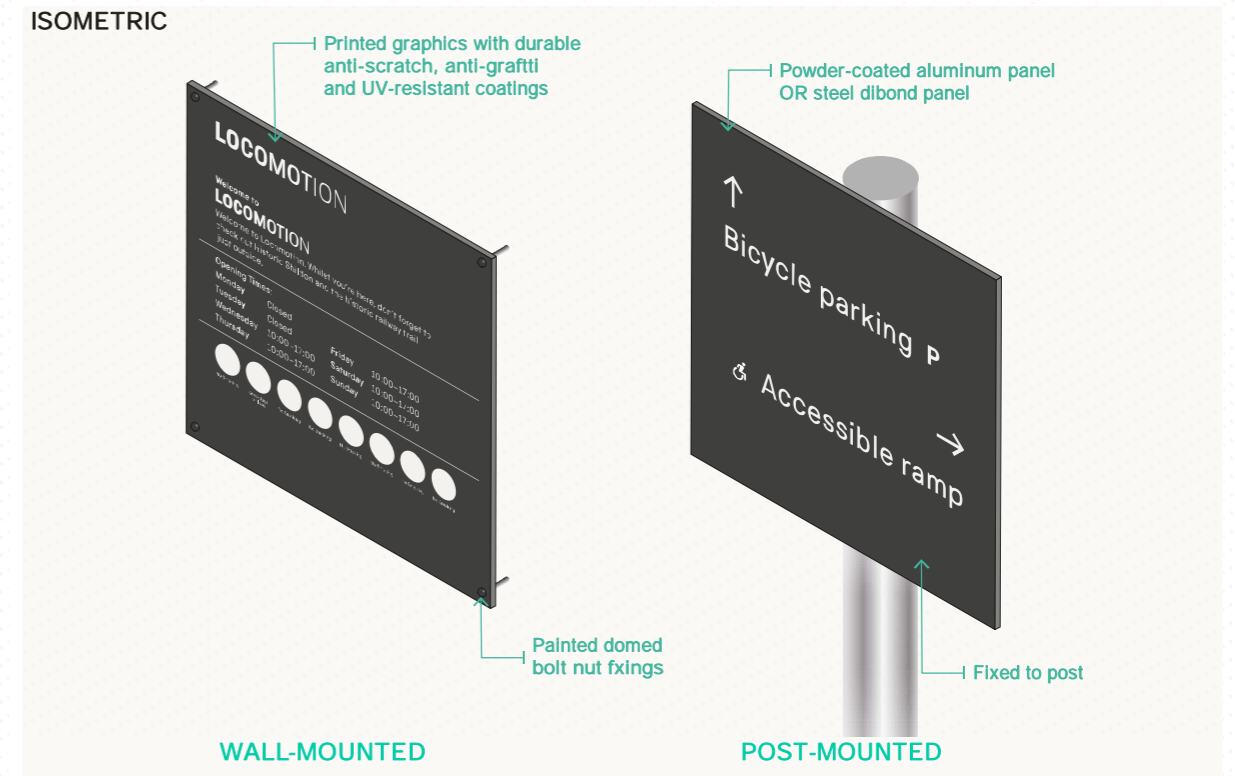

PNL  
*Panel Large*

Provide overview information with minimal footprint.  
Suitable for internal or external use on walls, posts and fencing.

- Dimensions :** 510 x 510 x 5 mm  
**Specifications :** Aluminium panels with matt powdercoat finish including edges  
 OR steel dibond panel with black core and sealed edges  
 Printed graphics and eased roundover edges (1-2 mm raised lettering for opening times)  
 Hidden fixings colour matched to panel, and method to suit mounting surface (wall/post/fencing)  
 Antiglare, UV-water-resistant, Anti-scratch coatings ideal

- Content :** Identification, Information, Statutory  
**Reading range :** 1.5-10 m  
**x-Height :** 3.75, 7.5, 15, 22.5 mm  
**Pictogram :** 45 mm  
**Character limit :** 20-30 characters per line (25 character max per statutory icon)  
**Additional:** Mounted at 1.2-1.5m above F/L

**RAL 9003**  
SIGNAL WHITE  
Printed graphics

**RAL 9011**  
GRAPHITE BLACK  
Panel background

PNL

*General assembly*

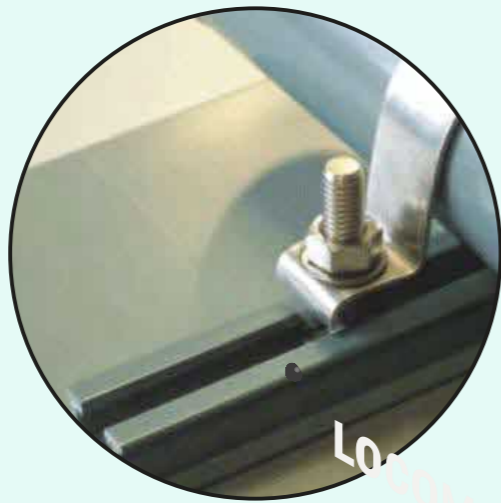
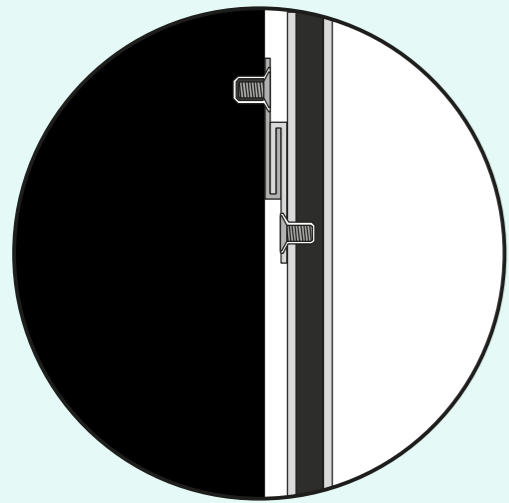

Fixing method to suit mounting surface  
Fixed to wall with hidden panel fixing,  
countersunk screws and split baton to mount  
OR  
Fixed to post using standard mount fixing  
fitted to channel bracket welded on panel rear

Protective coatings ideal  
(Anti-glare/ scratch/ graffiti,  
UV/ Water-resistant)

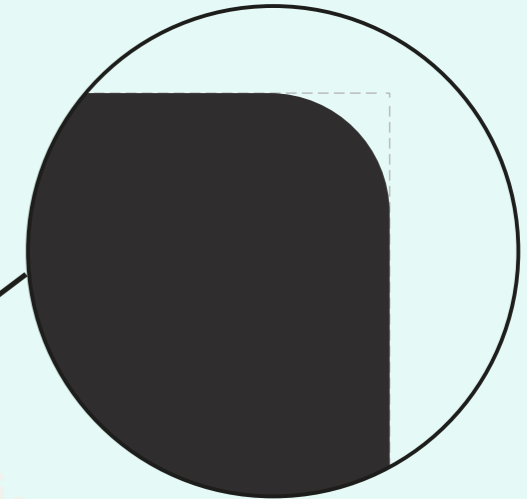
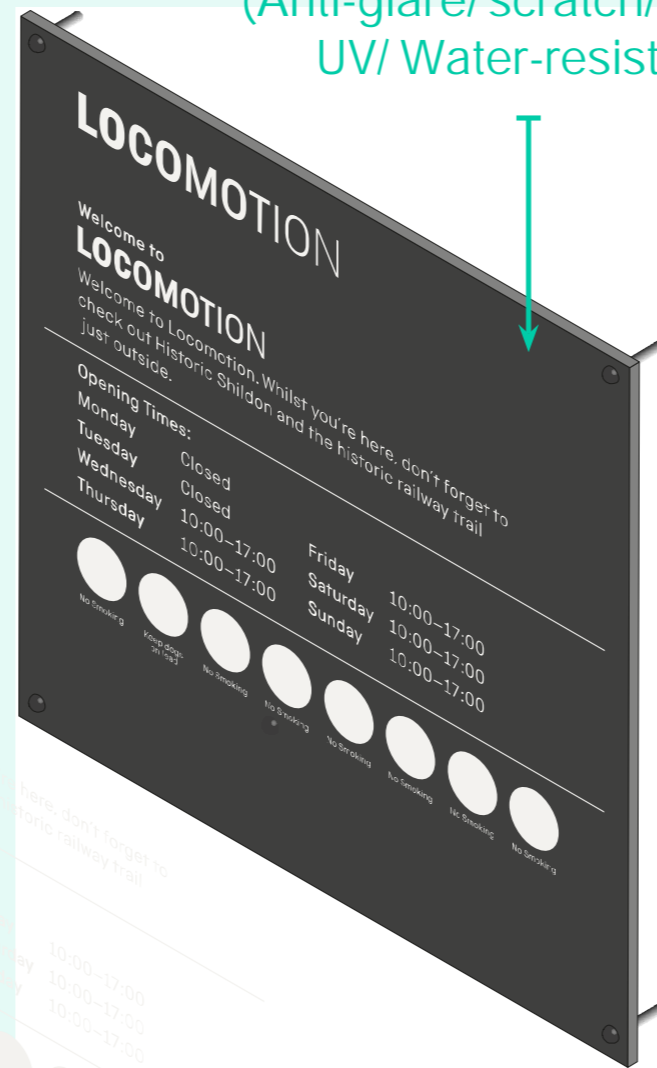

roundover edge profile

Graphics printed  
direct to media



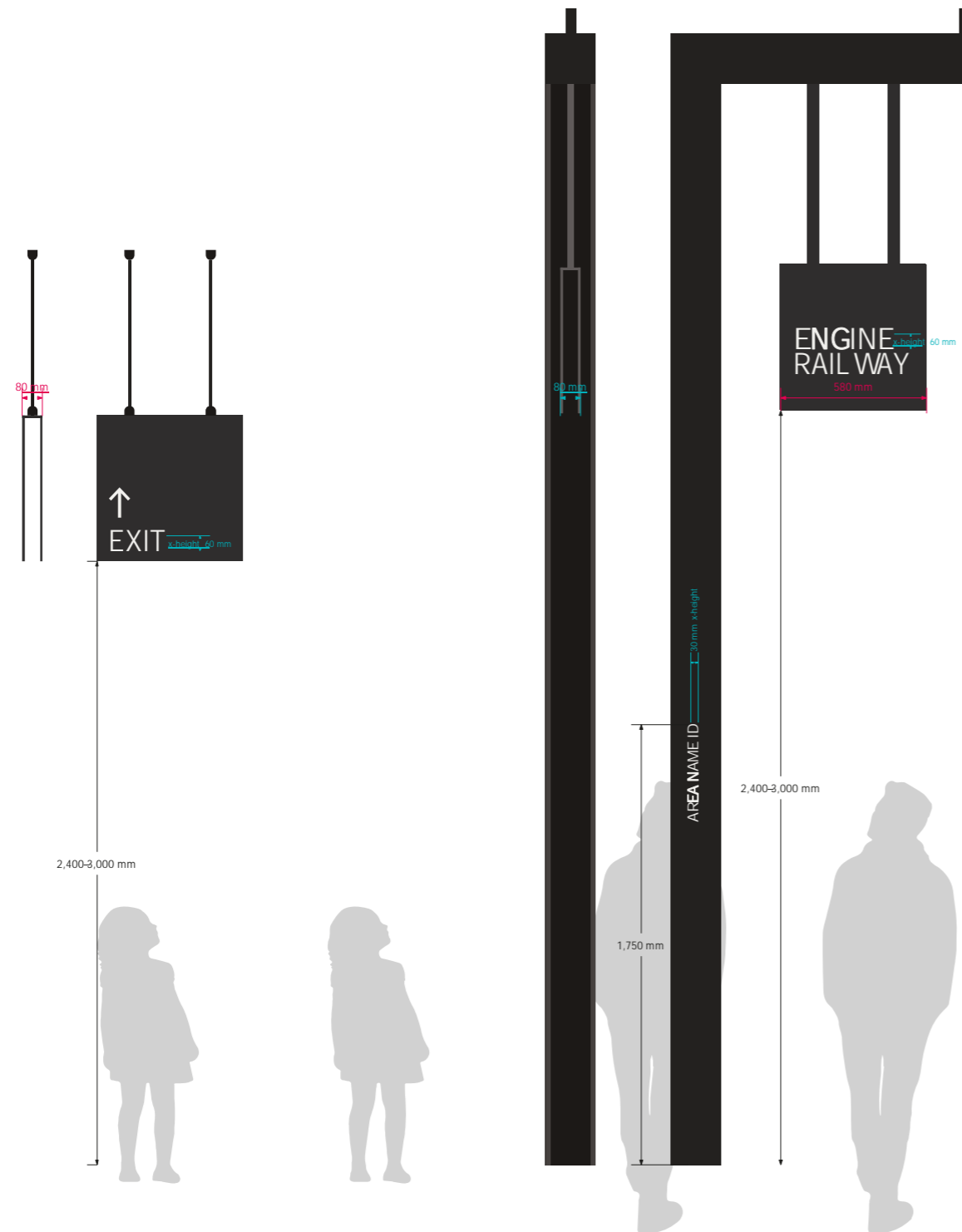

NEW HALL INDOOR VARIATION

SHILDON RAIL TRAIL VARIATION

SHOWN @ 4% SCALE



PNQ

*Panel Square*

Direct to destinations along trails and aisles, and identify outdoor attractions.

- Dimensions :** 580 x 580 x 80 mm
- Specifications :** Powdercoated 5mm folded aluminium panel, post and fixings  
Printed graphics on panels and eased roundover edges  
Transparent vinyl or stencilled graphics on post (lettering and/or statutory icon)  
Panel supported by welded galvanised rods from post OR wire with ceiling anchor and stop.  
Antiglare, UV-water-resistant, Anti-scratch coatings ideal

- Content :** Direction, Identification
- Reading range :** 14-27 m
- x-Height :** 30 , 45 , 60 mm
- Character limit :** 10 characters per line for identifiers,  
15 characters per line for directions, up to x2 directions
- Additional:** Signature typesetting (for Attractions/Area IDs only)  
Suspended from ceiling over aisles or from existing gallow beams  
Panels suspended at 2.4-3m above F/L

**RAL 9003**  
SIGNAL WHITE  
Printed graphics

**RAL 9011**  
GRAPHITE BLACK  
Powdercoat aluminium  
panel, post and fixings

PNQ (external)

*General assembly*

1. Drill holes into Structural Post

2. Fit Supports to Structural Post and secure with four off M6 Dome lock-nuts and M6 Caphead screws, per Support.

3. Fit Panel to Supports and secure with four off M6 Dome lock-nuts and M6 CNSK screws, per Support.

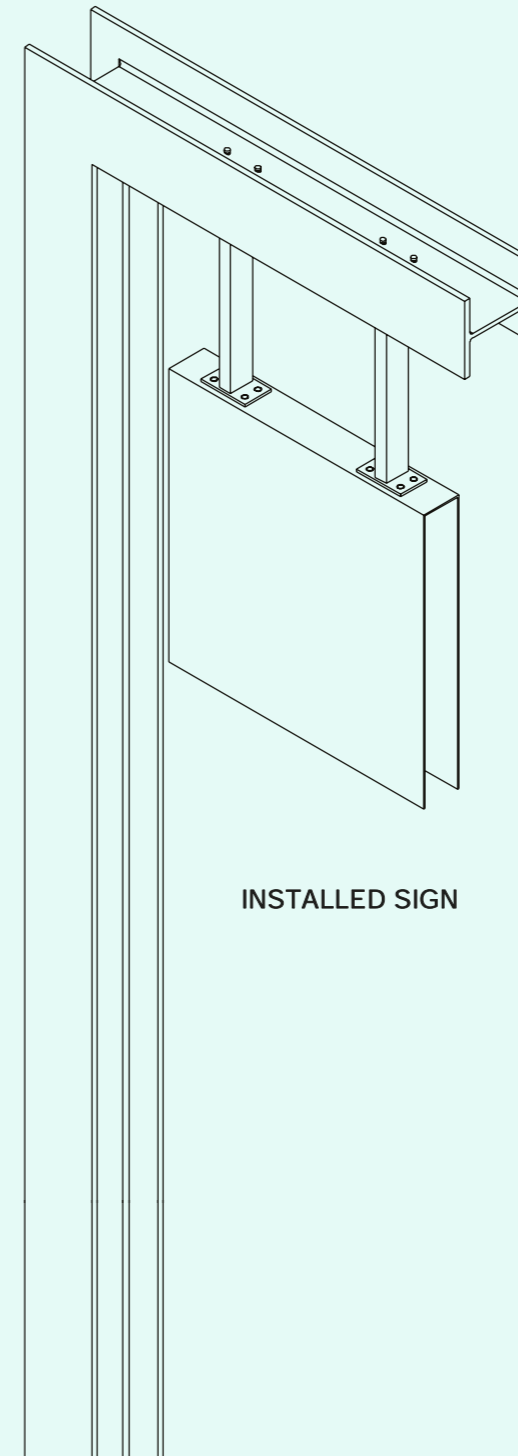
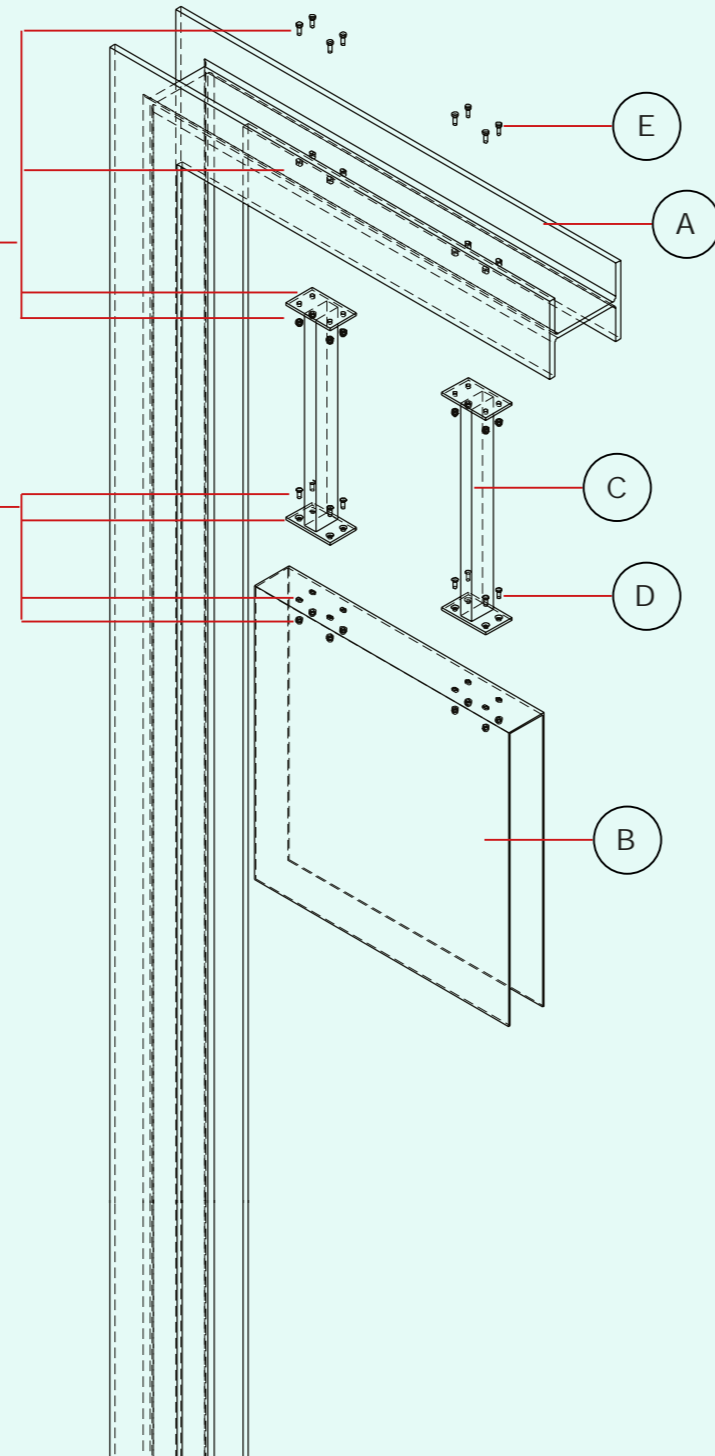
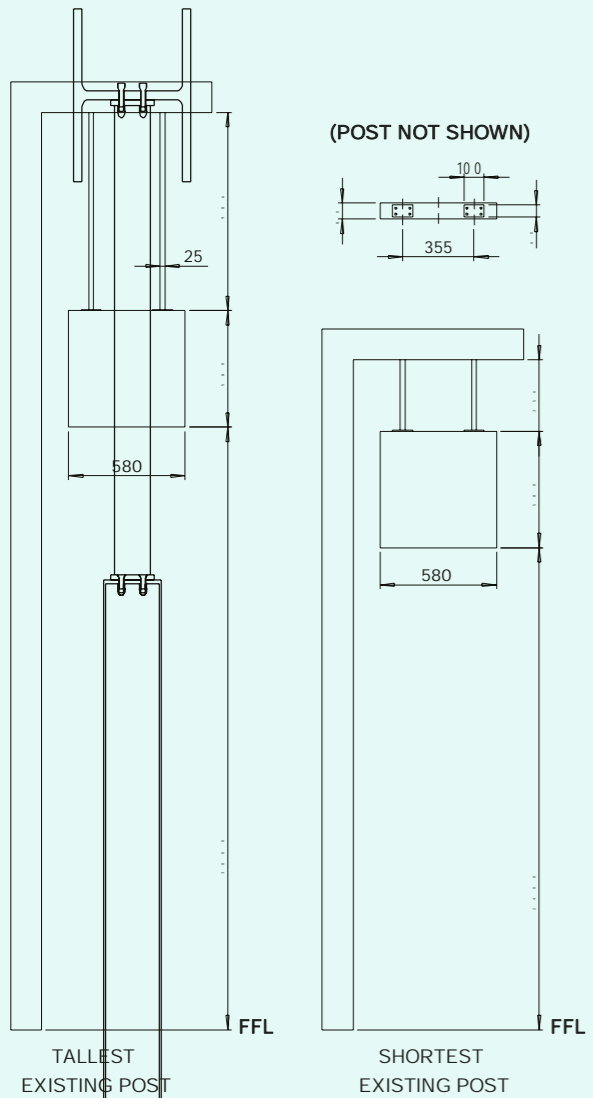

COMPONENTS

- (A) **Structural Post.**  
Existing UC Post.  
Painted: Satin, Graphite Black RAL 9011
- (B) **Panel.**  
3mm thk Aluminium.  
Anodised: Satin, Black to match Graphite Black RAL 9011.  
With screen printed or digitally print graphics - details supplied separately  
Removable for graphic updates.
- (C) **Supports.**  
Welded assembly: 25 x 50mm galvanise pipe, 3mm thk plates full-fill welded to each end.  
Remove any galv-flash or burrs, touch up any exposed MS with zinc rich primer. Painted: Satin, Graphite Black RAL 9011. Note: sizes and details TBC to Structural Engineer.
- (D) **Fixings to Sign.**  
M6 Dome lock-nut, Black.  
M6 SS CNSK screws, Black.  
M6 anti-vibration washers, Black.
- (E) **Fixings to Post.**  
M6 Dome lock-nut, Black.  
M6 SS Caphead screws, Black  
M6 anti-vibration washers, Black.

**JED 1235/04/001**

**MIMA - NRM WAYFINDING SIGNAGE**

**PANEL SUSPENDED (PNQ)**

**Main Assembly**

Notes

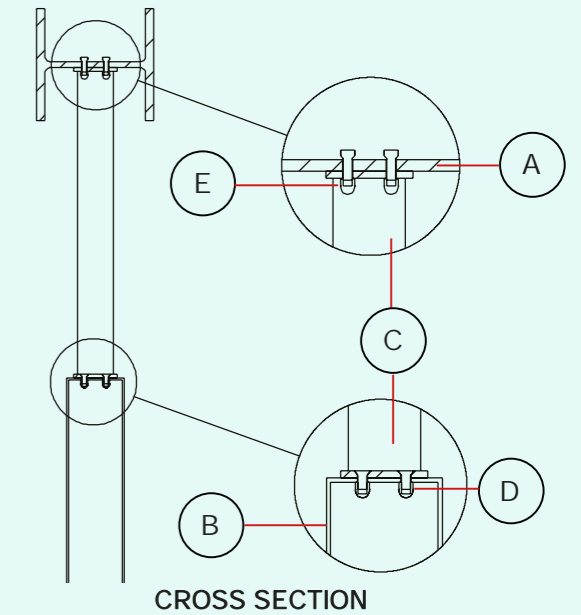

**JED 1235/04/001**

**PNQ (internal)**

*General assembly*

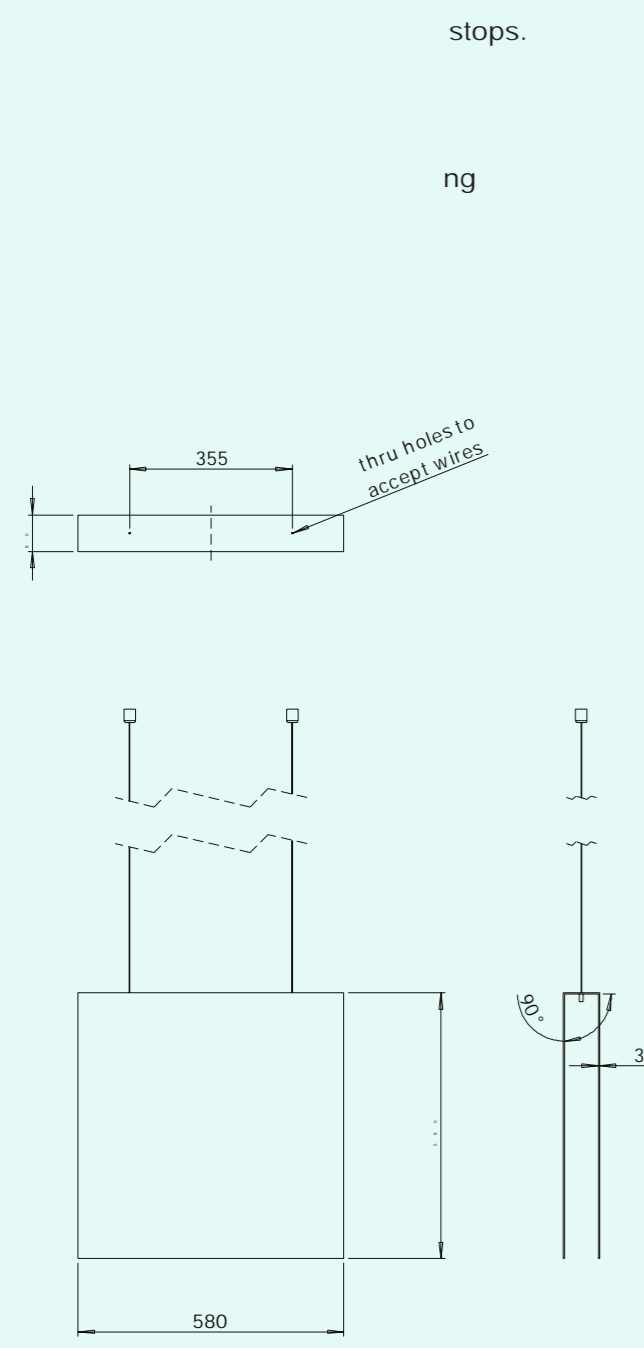

1. Fit Ceiling Anchors to beam as per manufacturers instructions. Drill holes as required.
2. Adjust length of wire to required hanging length.
3. Thread the wire through the top holes in the Panel. Use a swaging tool to clamp the End stops onto the wire, on the underside of the panel. Neatly cut off excess wire.

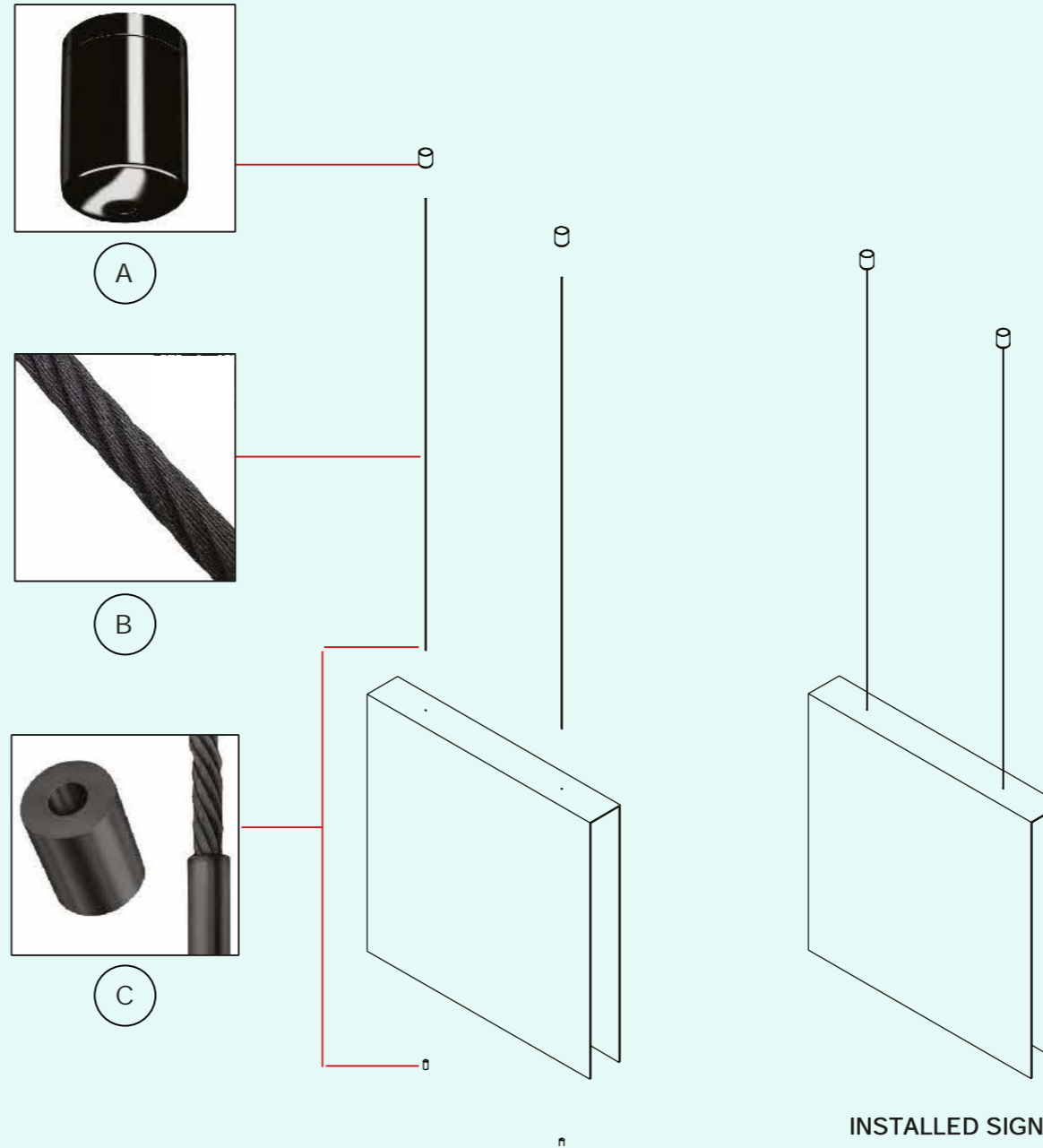

**MIMA - NRM WAYFINDING SIGNAGE COMPONENTS**

**PANEL SUSPENDED (PNQ)**  
 Panel: 3mm thk Aluminium.  
 Main Assembly: Polished: Satin, Black to match Graphite Black RAL 9011.

**JED 1235/04/001**  
 Notes: With screen printed or digitally print on the panel. Panels supplied separately. Removable for graphic updates.

**MIMA - NRM WAYFINDING SIGNAGE**  
 Wire and End Stops: 1.5-3mm thick steel wire en-Black

**PANEL SUSPENDED (PNQ)**  
 Main Assembly: Hanging Anchors. 1.5-3mm thick steel wire ceiling anchors. Black

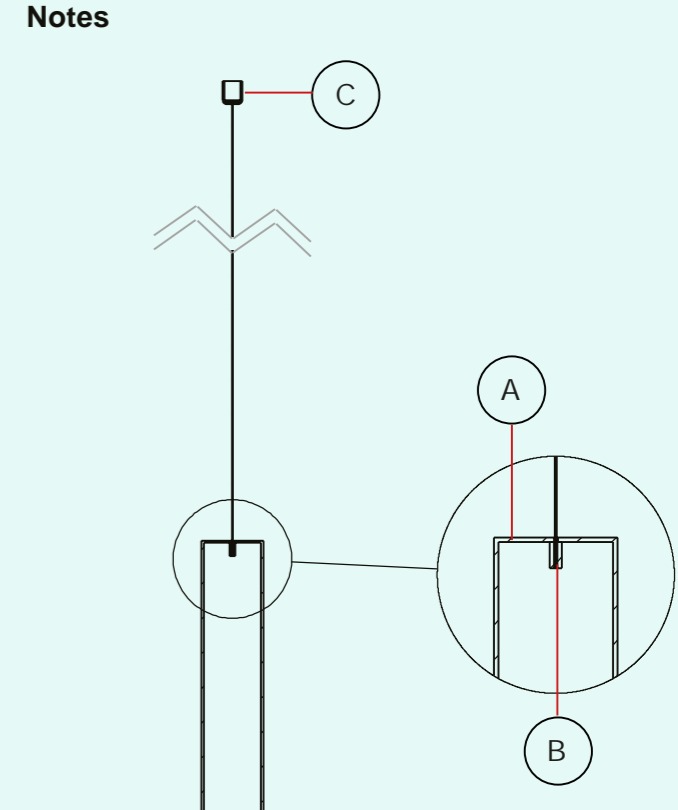

Drawn by: JA  
 Checked by: EG  
 CROSS SECTION SHOWING PANEL CONNECTIONS

Issue	Date	Note
1	04.23	

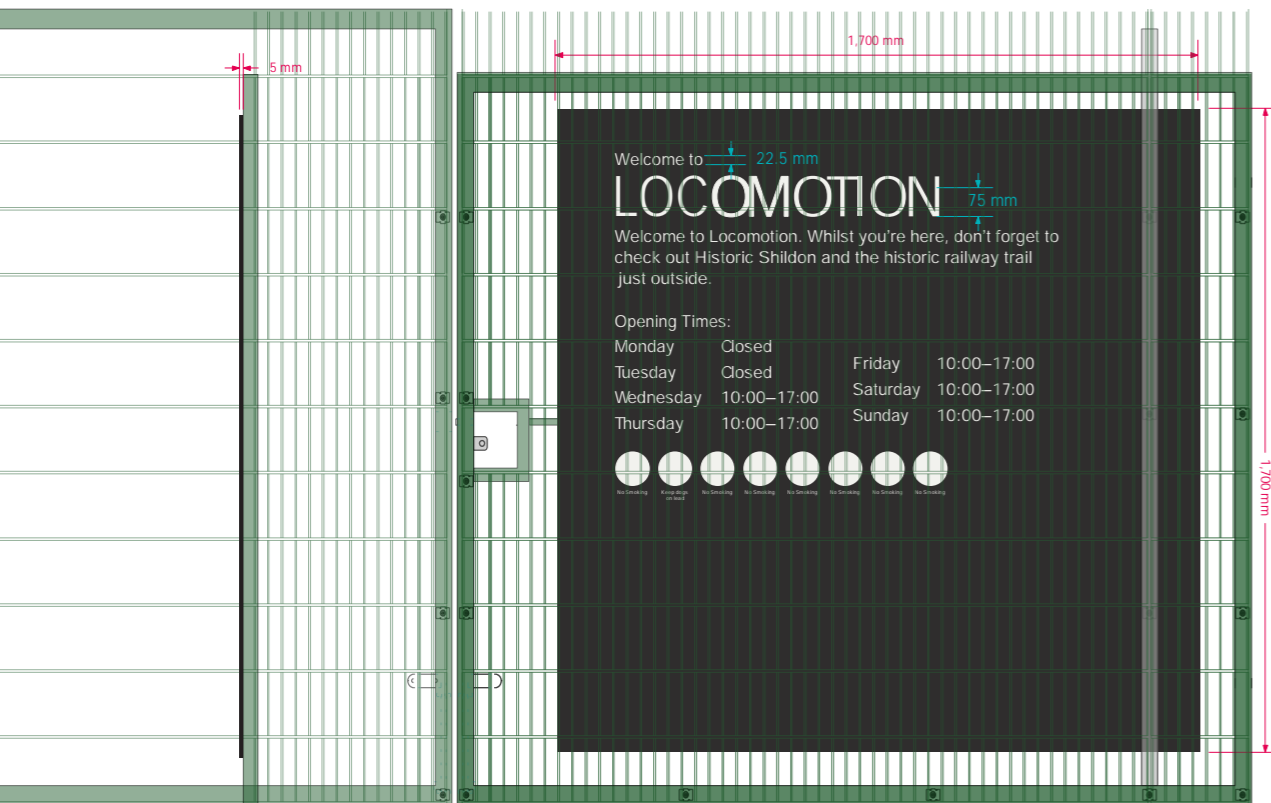

ISOMETRIC



## PNG *Panel Gate*

Welcome visitors to the museum, opening times and overview information.

**Dimensions :** ±1700 x ±1700 x 5 mm

**Specifications :** Anodised powdercoated aluminium panel with eased roundover edges  
OR Dibond printed panel with black core and sealed edges  
Printed graphics (1-2 mm raised lettering for opening times)  
Concealed tamper-proof fixings to suit existing gate  
Antiglare, UV-water-resistant, Anti-scratch coatings.

**Content :** Information

**Reading range :** 2.5-10 m and 35 m

**x-Height :** 5, 22.5, 75 mm

**Character limit :** 50 characters per line (up to 10 lines)

**Additional:** Primary typesetting  
Fixed to existing entry gate

### ELEVATIONS

SHOWN @ 5% SCALE

**RAL 9003**  
SIGNAL WHITE  
Printed graphics

**RAL 9011**  
GRAPHITE BLACK  
Panel background

PNG

*General assembly*

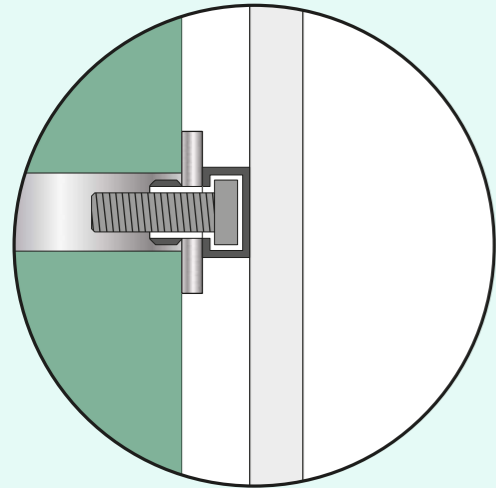

Fixing method to suit gate construction  
Tamper proof fixings to gate with a bracket fitted to a channel on the rear of the sign.

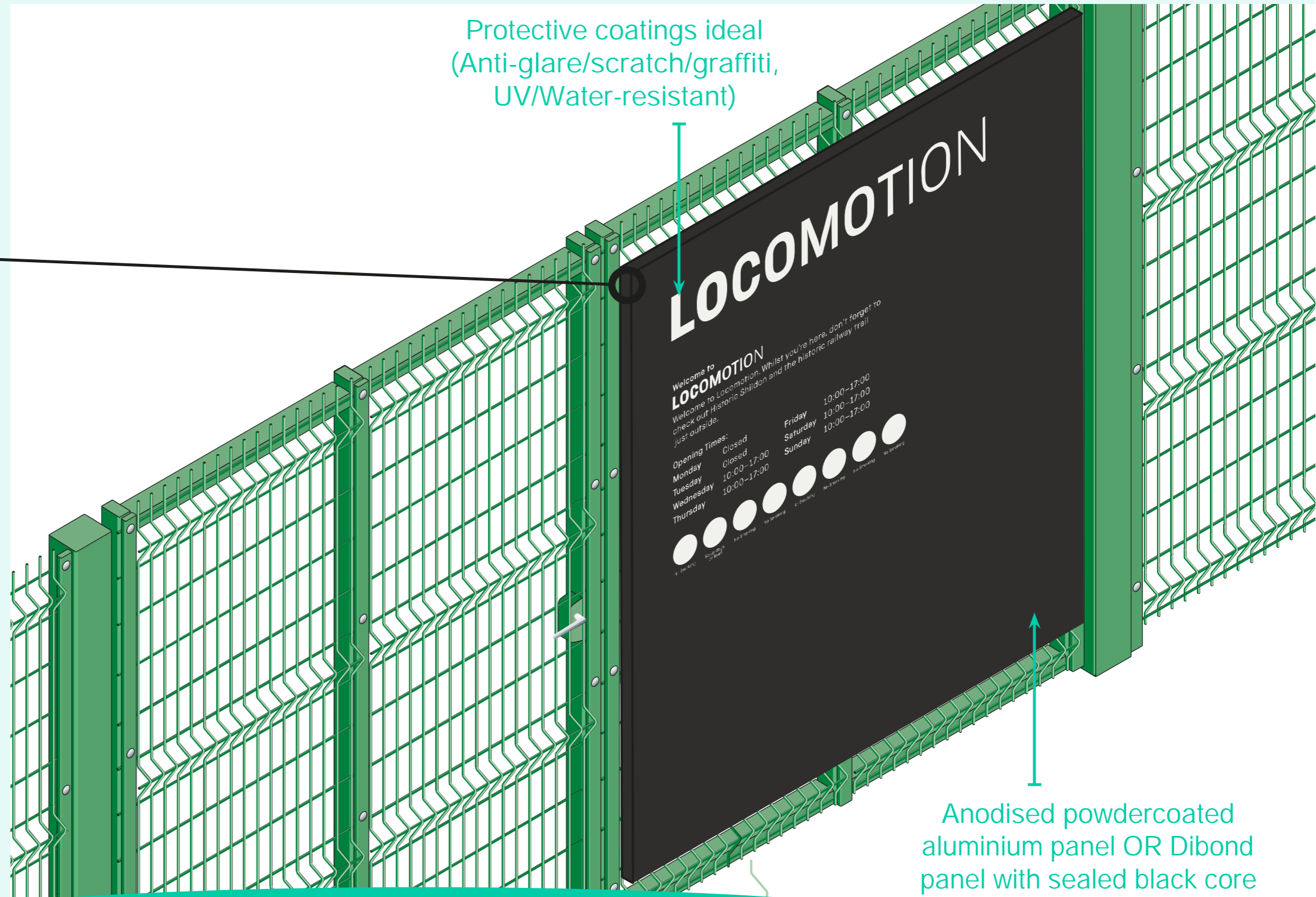

Protective coatings ideal  
(Anti-glare/scratch/graffiti,  
UV/Water-resistant)

Anodised powdercoated  
aluminium panel OR Dibond  
panel with sealed black core

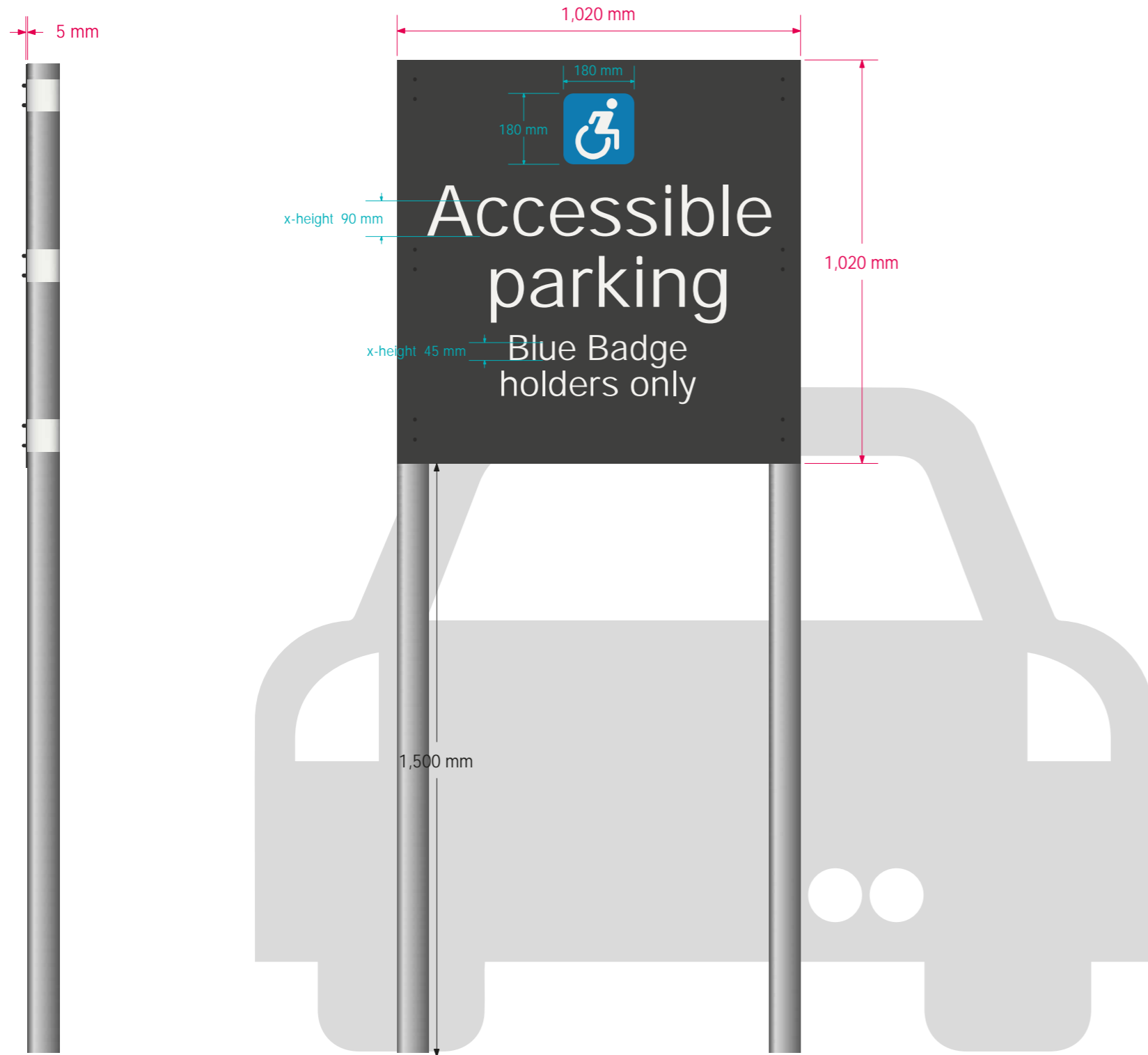

ELEVATIONS

SHOWN @ 7.5% SCALE

ISOMETRIC

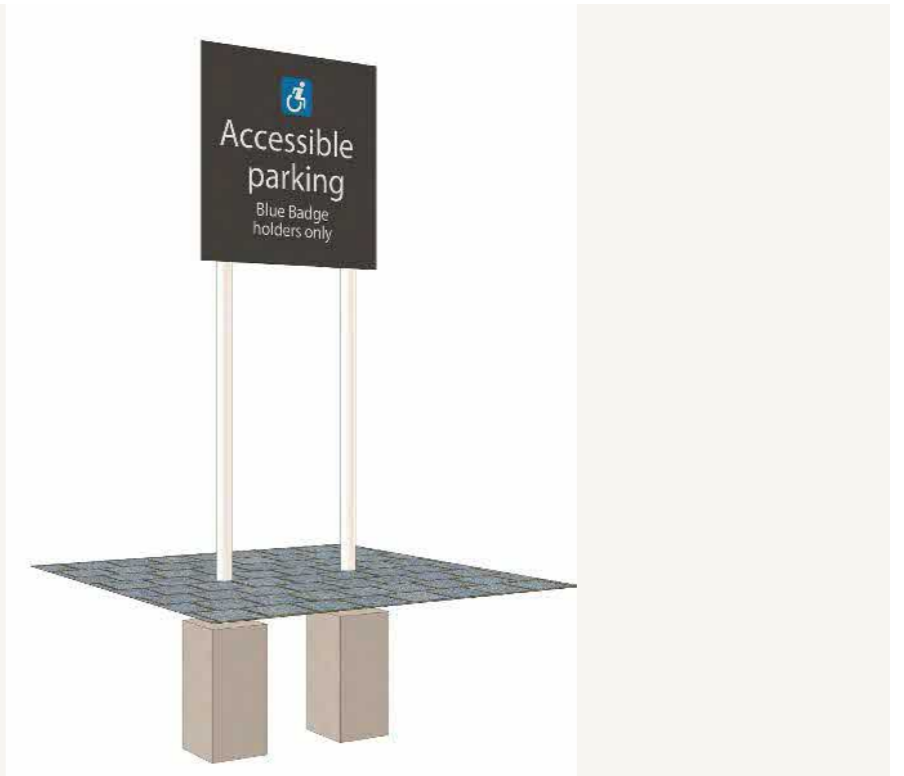

RDL

*Road Sign Large*

Direct and inform drivers at car parks.

- Dimensions :** 1020 x 1020 x 5 mm
- Specifications :** Dibond printed panel with black core and sealed edges  
Post mounted fixing method with domed bolt nuts and washers  
Antiglare, UV-water-resistant, Anti-scratch coatings ideal  
Nominated contractor to verify foundations and structural loading

- Content :** Direction, Identification, Information
- Reading range :** 20-40 m
- x-Height :** 45 , 90 mm
- Character limit :** 10-15 characters per line, 1-2 lines per direction (up to 3 directions)
- Pictogram :** 180 mm
- Additional:** Primary typesetting  
Mounted at 1.5m above F/L

**Note:** Low mounted signage to be avoided by parked vehicles

**PMS 293**  
ACCESSIBLE BLUE  
Pictogram icon only

**RAL 9003**  
SIGNAL WHITE  
Printed graphics

**RAL 9011**  
GRAPHITE BLACK  
Dibond panel  
background

RDL

*General assembly*



1. Fit Panel to Structural Post and secure with Standard post-mount street sign fixing, to channel bracket welded on rear and secure to post.

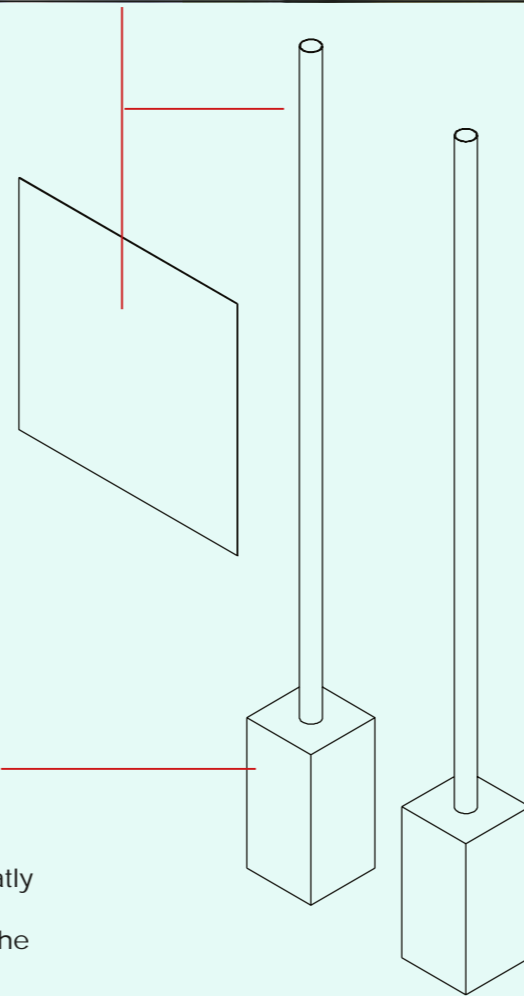

2. Position and fix the sign onto the Foundations.

3. Replace and neatly finished floor level substrate around the installed sign.

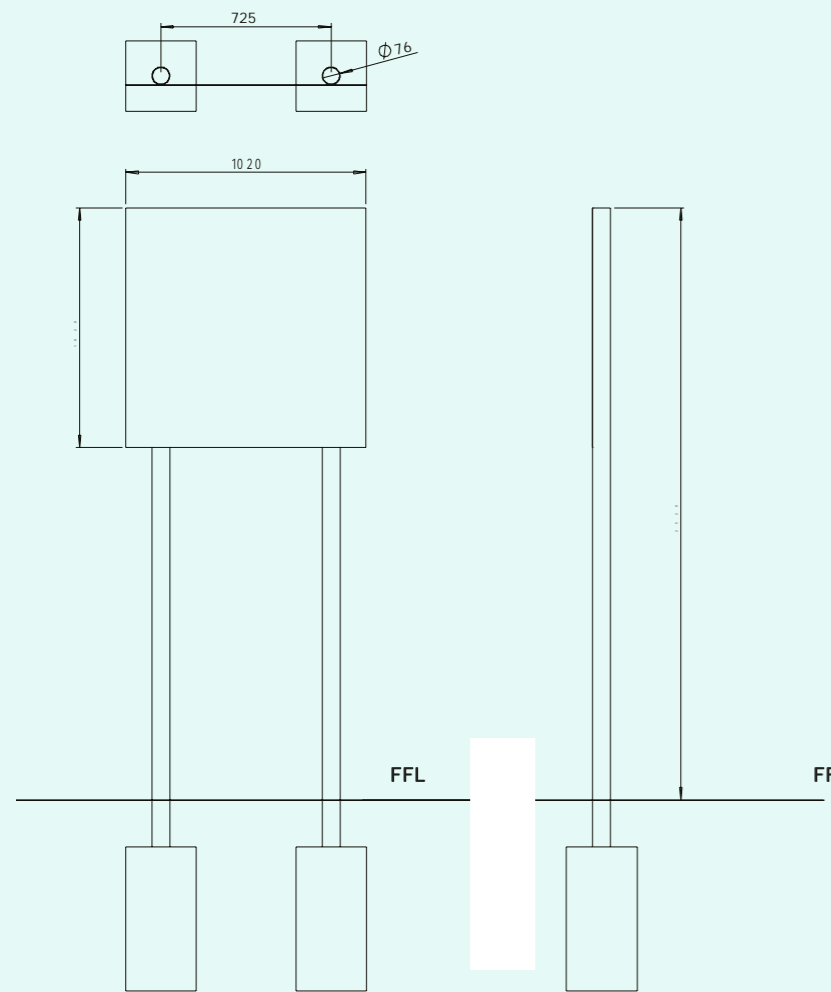

COMPONENTS

- (A) **Structural Posts.**  
Ø 76/ 3" Galvanised Steel Post.  
Set into concrete foundations.
- (B) **Panel.**  
3mm Dibond matte black.  
With screen printed or digitally print graphics - details supplied separately  
Removable for graphic updates.
- (C) **Fixings.**  
Standard post-mount street sign fixing, with channel welded to rear and bracket to secure to post.
- (D) **Foundations.**  
Reinforced concrete.  
Supplier can propose alternative solution. Size sufficient to prevent overturning for Wind Loading.  
TBC by a suppliers Structural Engineer

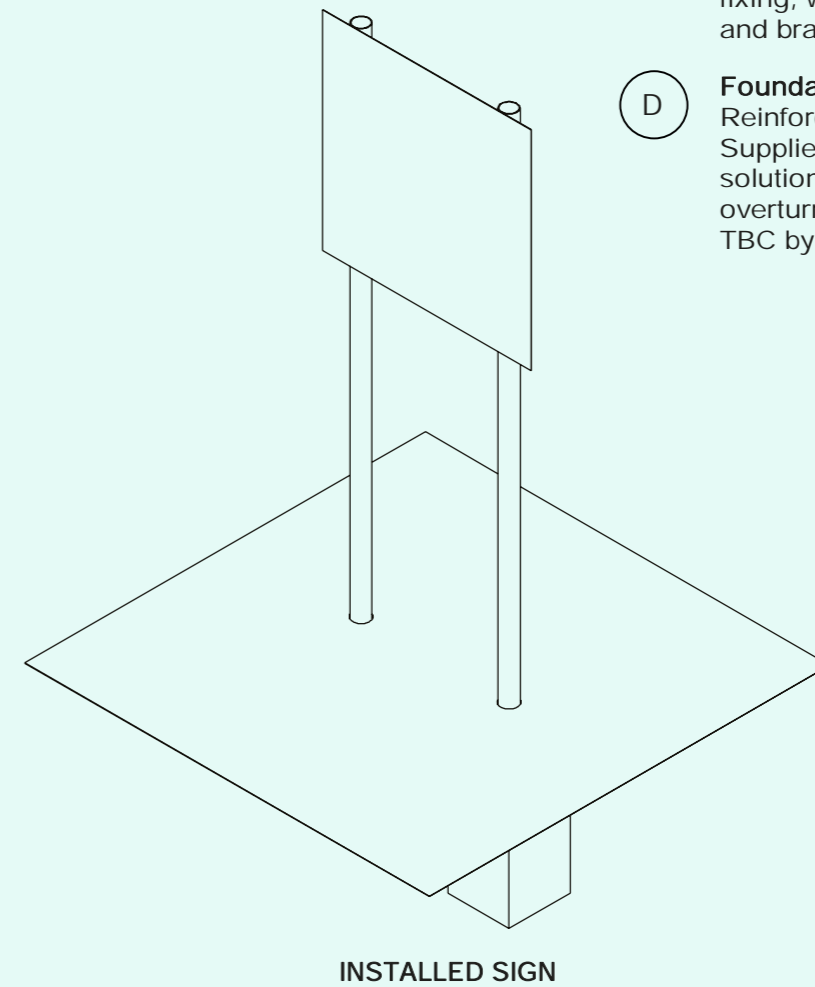

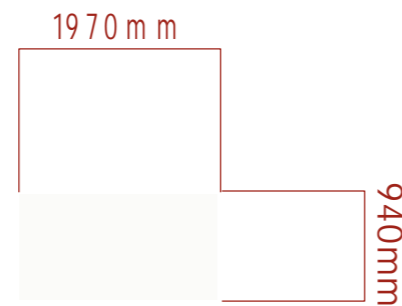

## VNW

### *Vinyl (Window)*

Informs and welcomes visitors and includes map of the site.

**Dimensions :** 1970 x 940 x 1 mm

**Specifications :** Self-adhesive vinyl (3M or similar)  
 Opaque matt finish (with antiglare/UV/water-resistant coatings ideal)  
 Applied to both sides of glazed panel

**Content :** Identification, Information, Orientation

**Reading range :** 3.5-4 m

**x-Height :** 7.5, 9, 22.5, 30 mm

**Character limit :** 10-20 characters per legend line item

**Pictogram :** 15 mm

**Map:** 725 x 725 mm

**Additional:** Mounted to glazing between the framing, to replace existing vinyl

**Note:** Illustration indicates location of vinyl only

**RAL 3002**  
 CARMINE RED  
 Accent details

**RAL 9003**  
 SIGNAL WHITE  
 Printed graphics

**RAL 9011**  
 GRAPHITE BLACK  
 Powdercoat aluminium  
 panel, trim and fixings

#### ELEVATIONS

SHOWN @ 1% SCALE



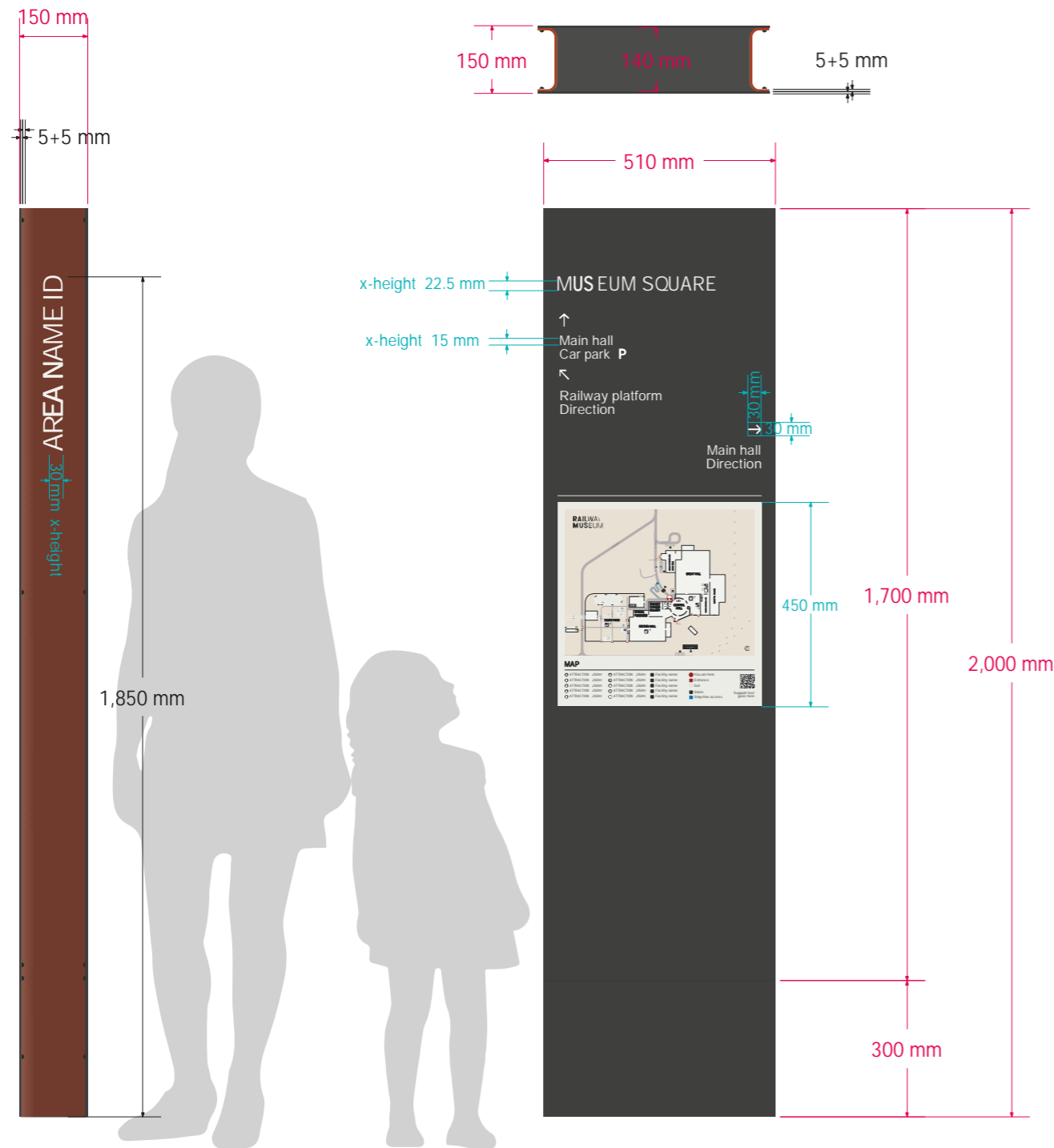

ELEVATIONS

SHOWN @ 7.5% SCALE

ISOMETRIC

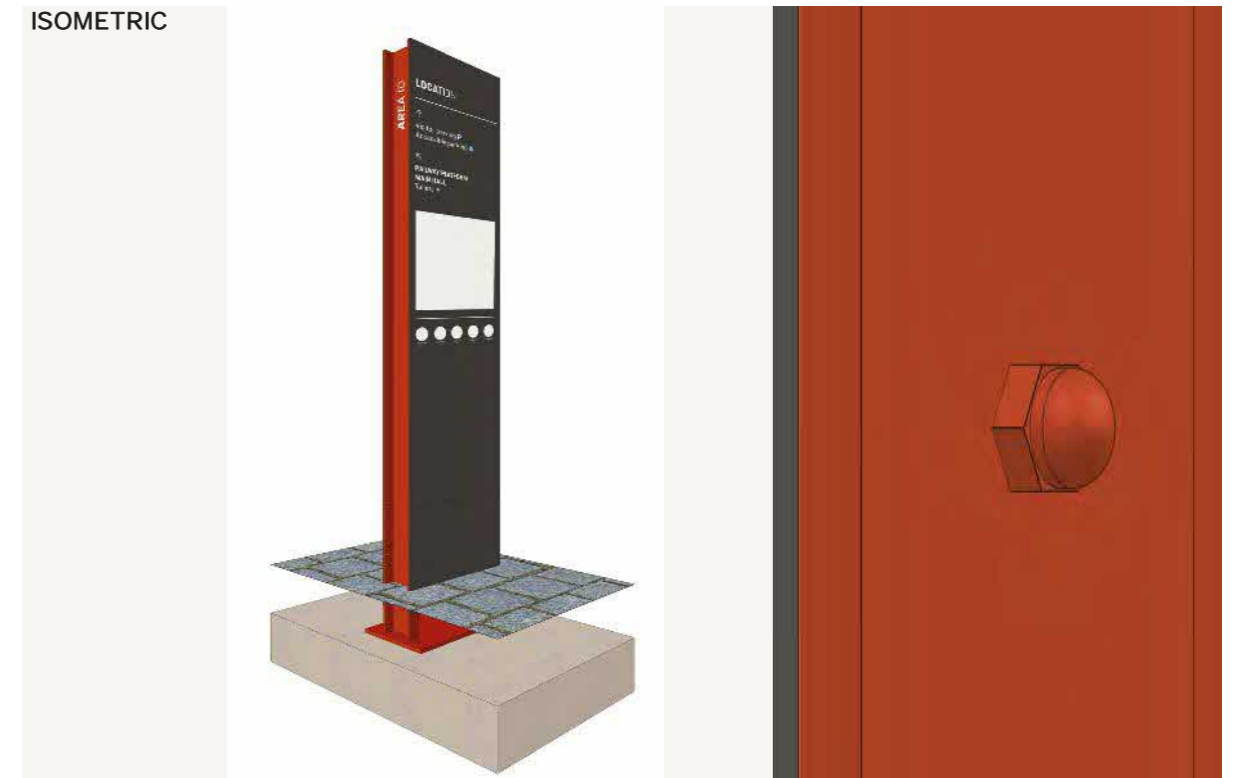

TOT  
*Totem*

Identify, inform, direct, and orient visitors around the sites.

**Dimensions :** 510 x 2000 x 150 mm

**Specifications :** 5mm anodised aluminium panels mounted to C-channel steel framework  
Powdercoat frame, panels with eased roundover edges and fixings (clinch stud and dome nuts)  
Printed graphics on updateable panel section and stencilled lettering on sides  
Floor-mounted (contractor to verify foundation and structural loading)  
Antiglare, UV-water-resistant, Anti-scratch coatings

**Content :** Direction, Identification, Information, Orientation

**Reading range :** 1.5-14 m

**x-Height :** 3.75, 5, 15, 22.5, 30 mm

**Map:** 450 x 450 mm

**Character limit :** 10-25 characters per line, 1-2 line items per direction (3 directions max)

**Additional:** Signature typesetting (Area Name ID only)

Lettering stencilled top down and applied at 0.25m from top of product

Painted contrast bands on post applied at 0.75m and 1.8m above F/L

**RAL 3002**  
CARMINE RED  
Powdercoat anodised  
aluminium C-channels

**RAL 9003**  
SIGNAL WHITE  
Printed graphics

**RAL 9011**  
GRAPHITE BLACK  
Powdercoat anodised  
aluminium panels

TOT

*Design specification intent*

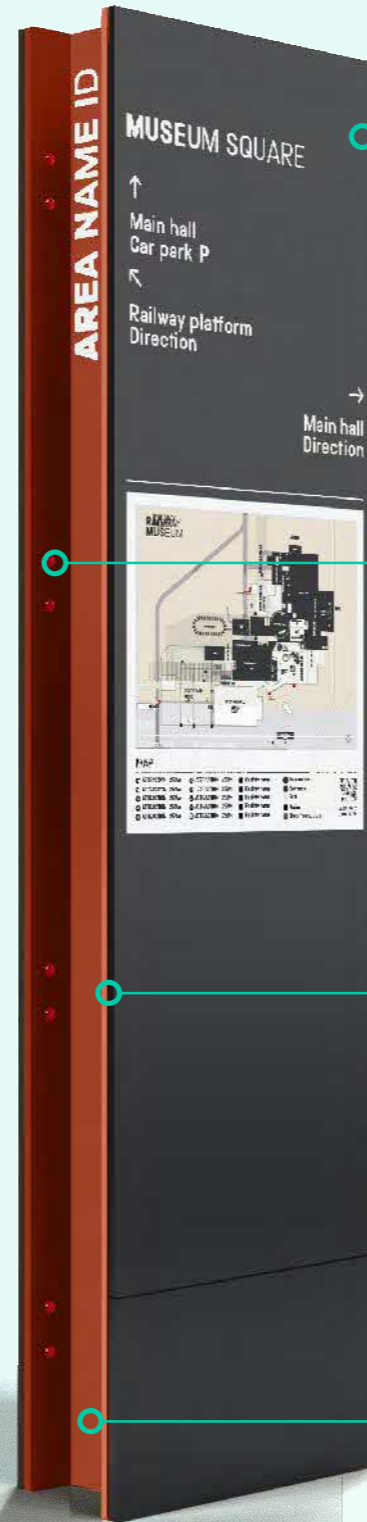

SLEEK DESIGN WITH UPDATEABLE GRAPHIC UPPER PANEL SECTION



TAMPER PROOF FIXINGS ARE HIDDEN FRONT+EXPOSED BACK (CLINCH STUD + DOMED HEX NUT)

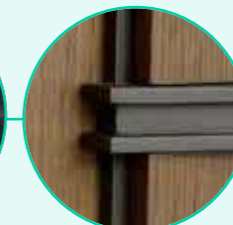

CONSTRUCTION BEAM AESTHETIC (ANODISED ALUMINIUM PANELS + C-CHANNEL STEEL FRAMEWORK WITH EASED ROUND OVER EDGES)

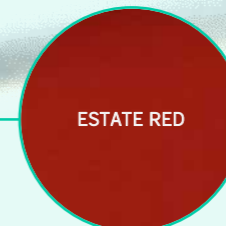

CONTRAST COLOUR ACCENT LINKS PRODUCT TO THE ESTATE

SHOWN @ 10% SCALE

TOT

General assembly

COMPONENTS

1. Fit Panels to Structural frame and secure with six off M6 Dome lock-nuts per panel.

Six M6 Clinch studs fitted to rear face of panels, before painting.

2. Using the lifting holes on the top of the Structural Frame, position and fix the sign onto the Foundations.

3. Replace and neatly finished floor level substrate around the installed sign.

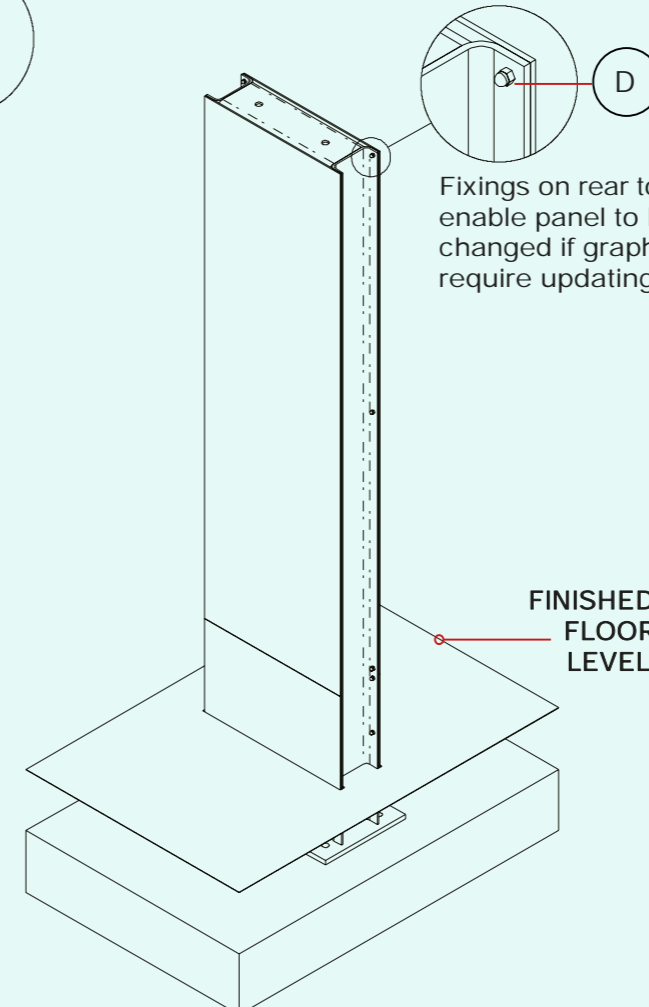
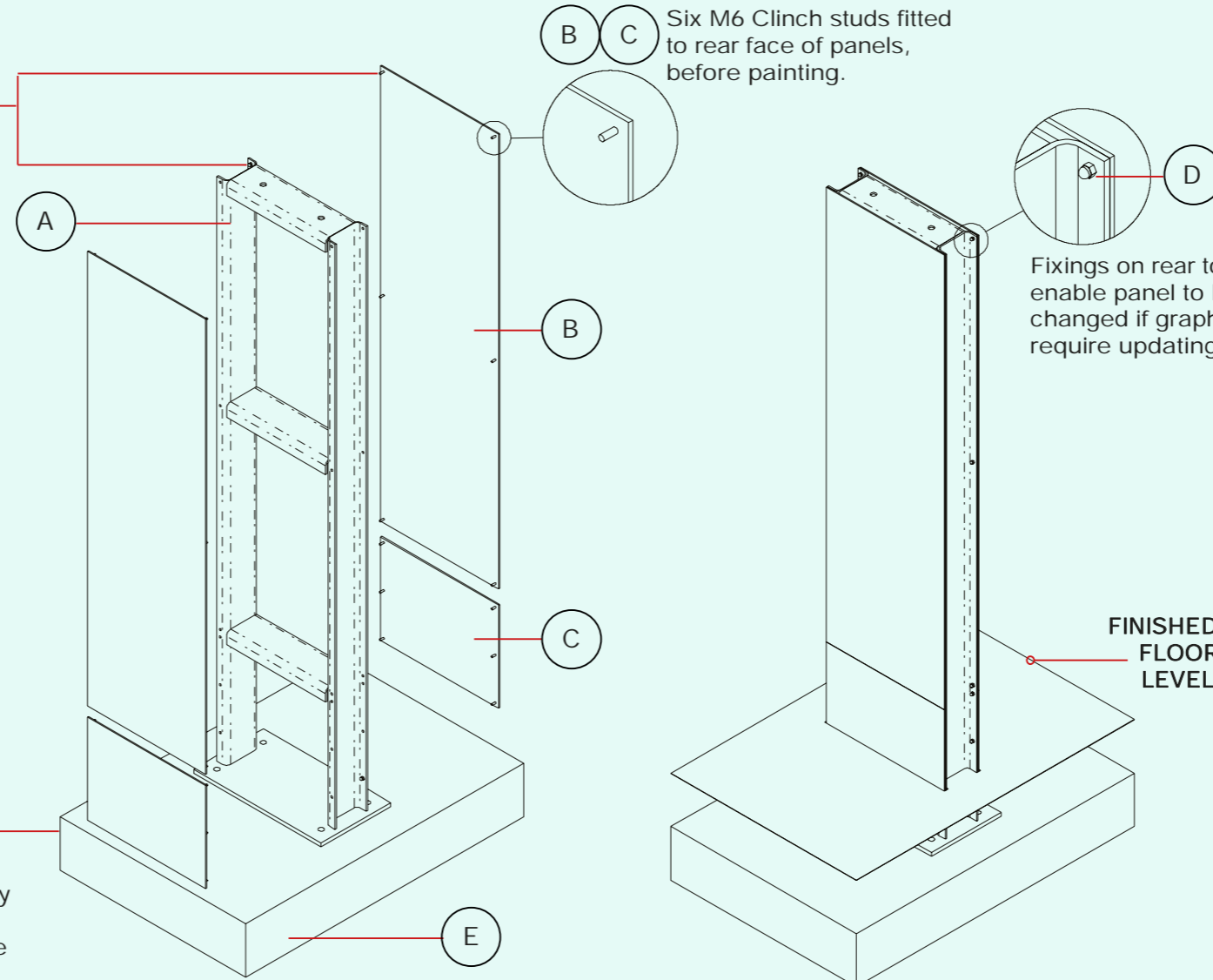
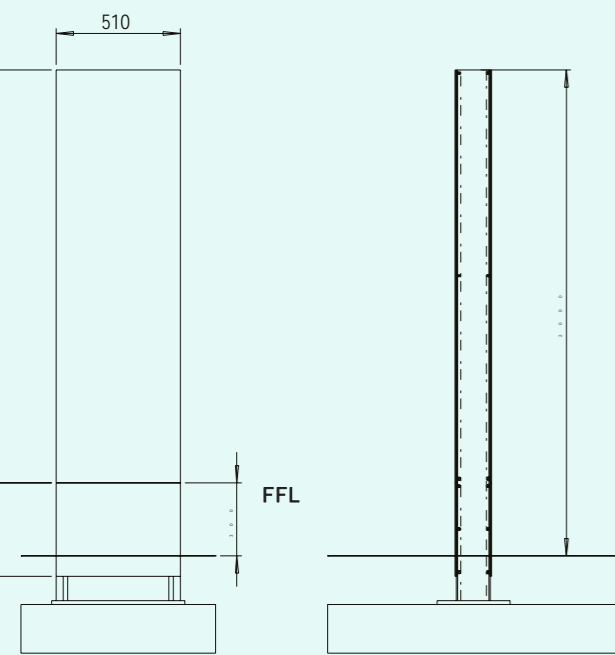
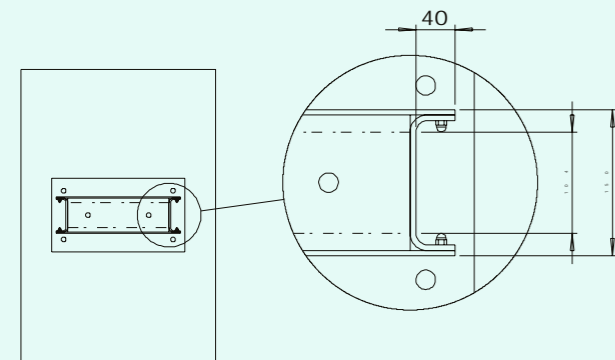

- (A) Structural Welded Assembly.**  
Welded assembly: made of 140 x 50 x 6mm thk folded galvanised MS side sections, top cap, cross beams and b plate. Top cap to include lifting point. Remove any galv-flash or burrs, touch up any exposed MS with zinc rich primer.  
PPC Matte Carmine Red RAL 3002. With screen printed or digitally print graphics - details supplied separately
- (B) Upper Panel.**  
5mm thk Aluminium.  
Painted: Satin, Graphite Black RAL 9011. With screen printed or digitally print graphics - details supplied separately. Removable for graphic updates.
- (C) Lower Panel.**  
5mm thk Aluminium.  
Painted: Satin, Graphite Black RAL 9011. Non-removable.
- (D) Fixings.**  
M6 Dome lock-nut.  
Painted: Matte Carmine Red RAL 300.
- (E) Foundations.**  
Reinforced concrete. Supplier can propose alternative solution. Size sufficient to prevent overturning for Wind Loading. Approx 1.2 x 0.8 x 0.2m. TBC by a suppliers Structural Engineer

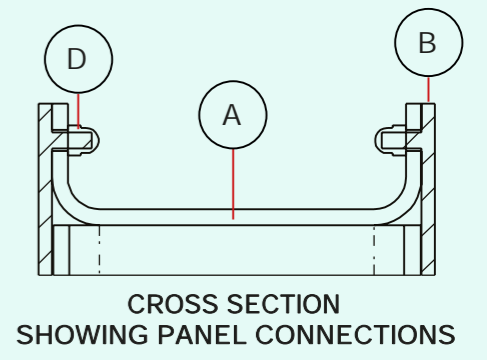

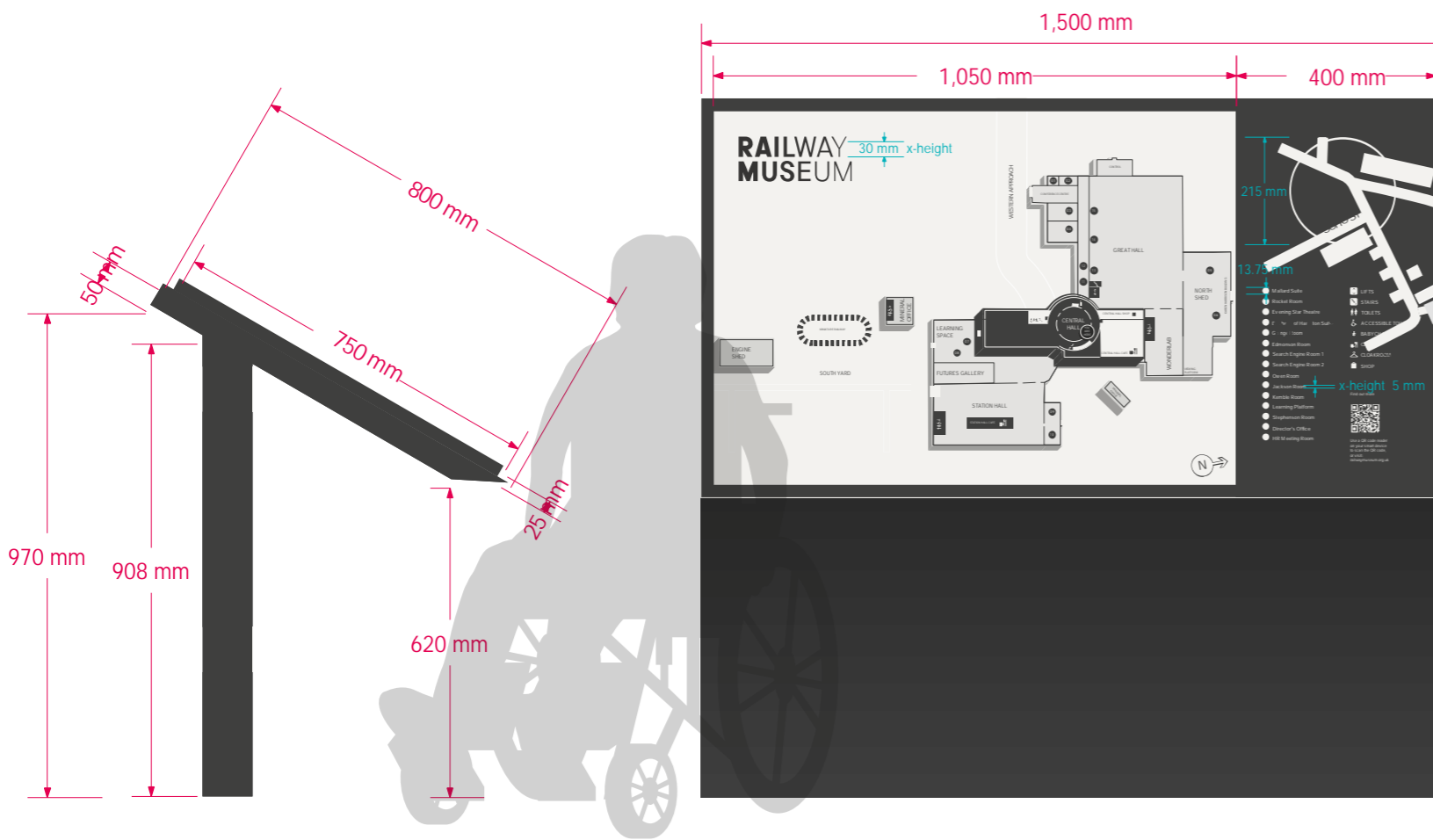

ELEVATIONS

SHOWN @ 7.5% SCALE

ISOMETRIC

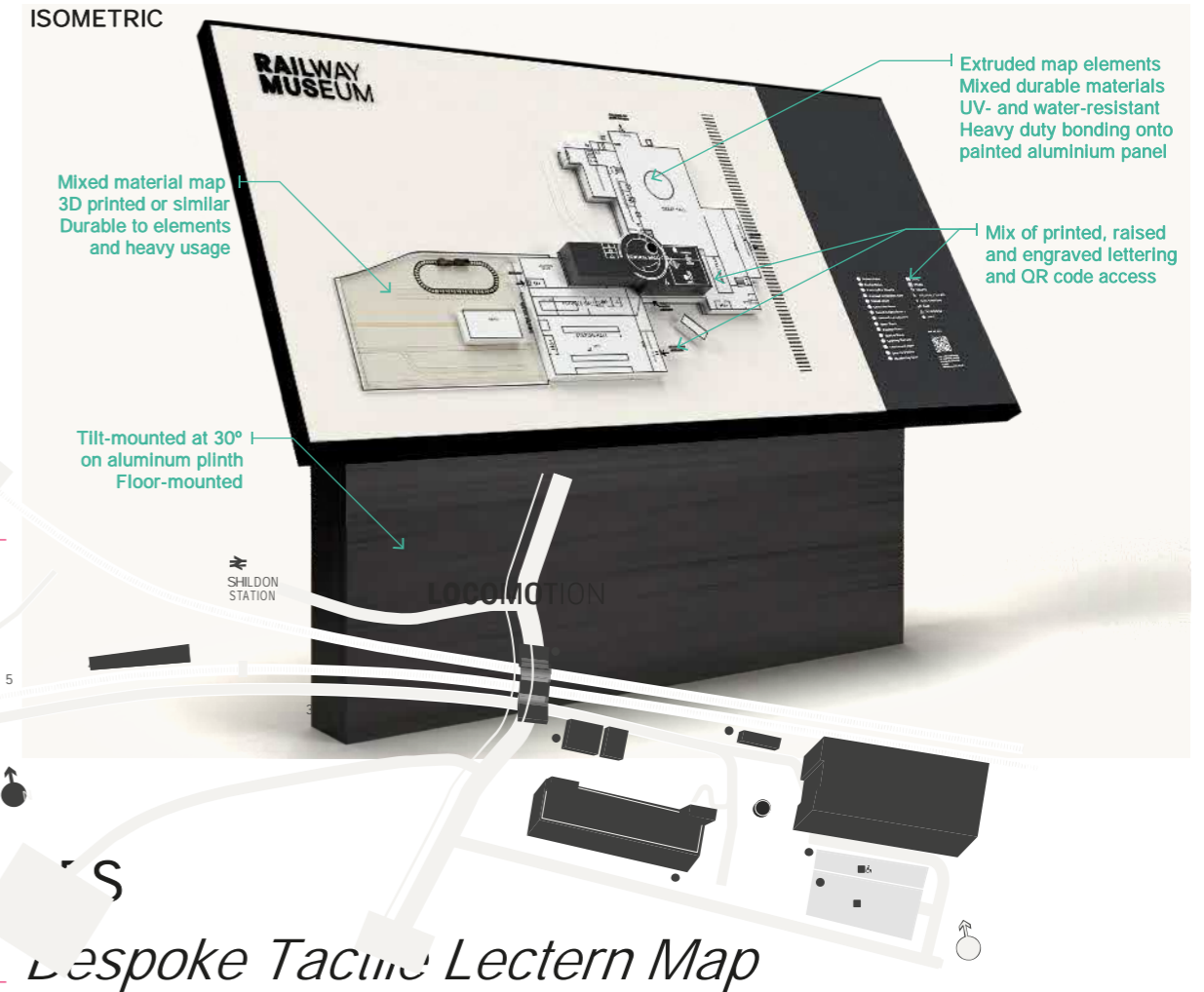

*Bespoke Tacine Lectern Map*

Provides an external site overview with engraved/extruded features.

**Dimensions :** 1500 x 800 x 1130 mm (map) , 1500 x 970 x 100 mm (plinth)

**Specifications :** Durable mixed material extruded map (3D laser printed or similar)  
 Extruded blocks, lasercut and raised lettering and pictograms  
 Durable bonds/extruded elements required to withstand frequent use  
 Mounted on to plinth, at 30° tilt (anodised aluminium/stainless steel)  
 Antiglare, UV/water-resistant, Anti-scratch coatings ideal

**Content :** Orientation

**Reading range :** 1.5-14 m

**x-Height :** 3.75, 5, 30 mm

**Character limit :** 10-20 characters per legend line item

**Map:** 1050 x 750 mm

**Additional:** Plinth-mounted at 30° tilt at 0.95 m above F/L (+600mm leg clearance)

**Note:** Map illustration is for demonstrative purposes only

**RAL 3002**  
 CARMINE RED  
 Accent details

**RAL 9005**  
 JET BLACK  
 Accent details

**RAL 9011**  
 GRAPHITE BLACK  
 Product structure and  
 printed content

**RAL 9003**  
 SIGNAL WHITE  
 Map background and  
 printed content

BES  
*Design specification intent*

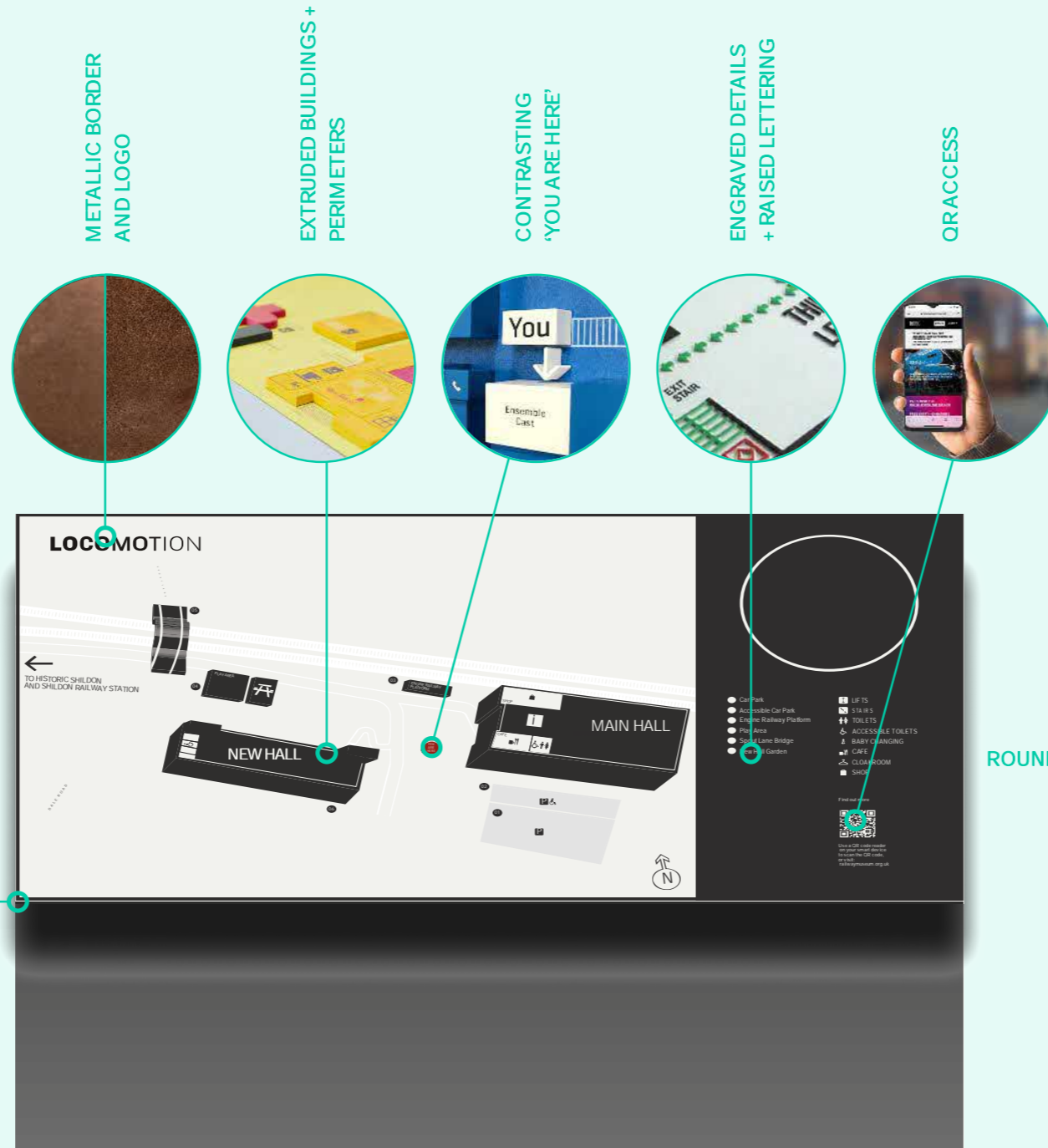
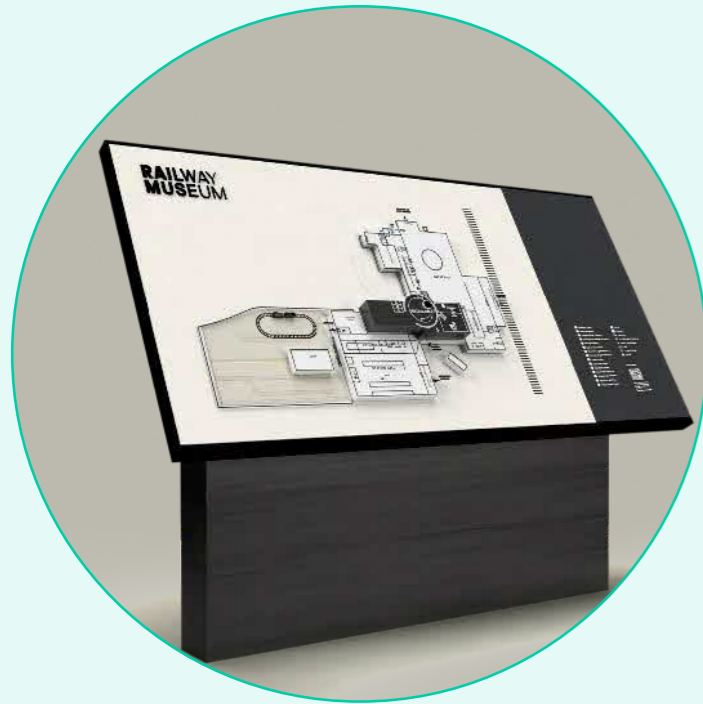

ROBUST BONDS

DURABLE MATERIALS

30° TILTED READING ANGLE

EASED ROUNDOVER EDGES

ANODISED POWDERCOATED ALUMINIUM FRAME

LEG CLEARANCE FOR WHEELCHAIR USERS

CONTRAST BANDS FOR VISIBILITY

SHOWN @ 10% SCALE

**UPDATED NOTE:**  
Vision 2025 lettering element to be removed from fabricated design

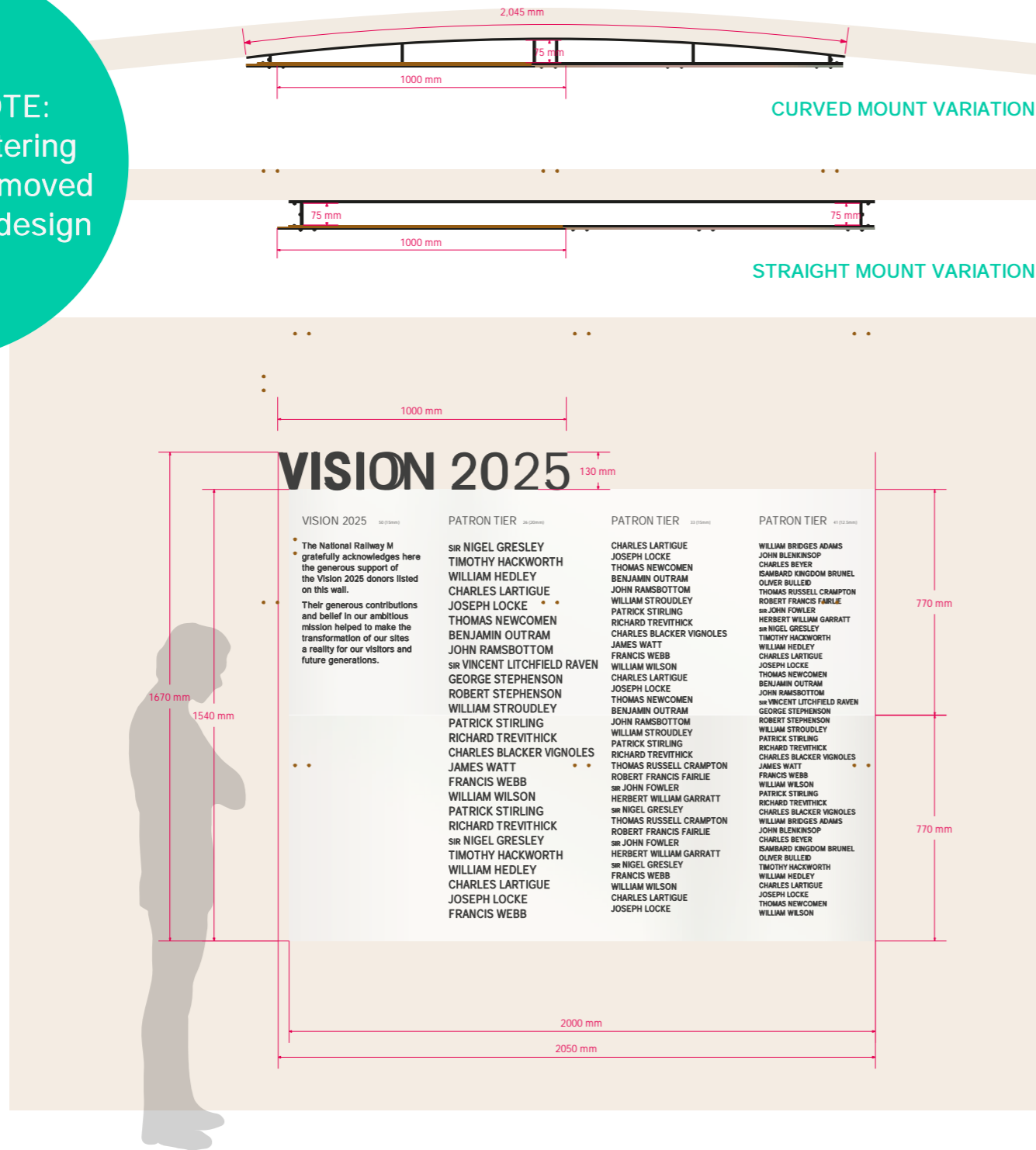

ISOMETRIC

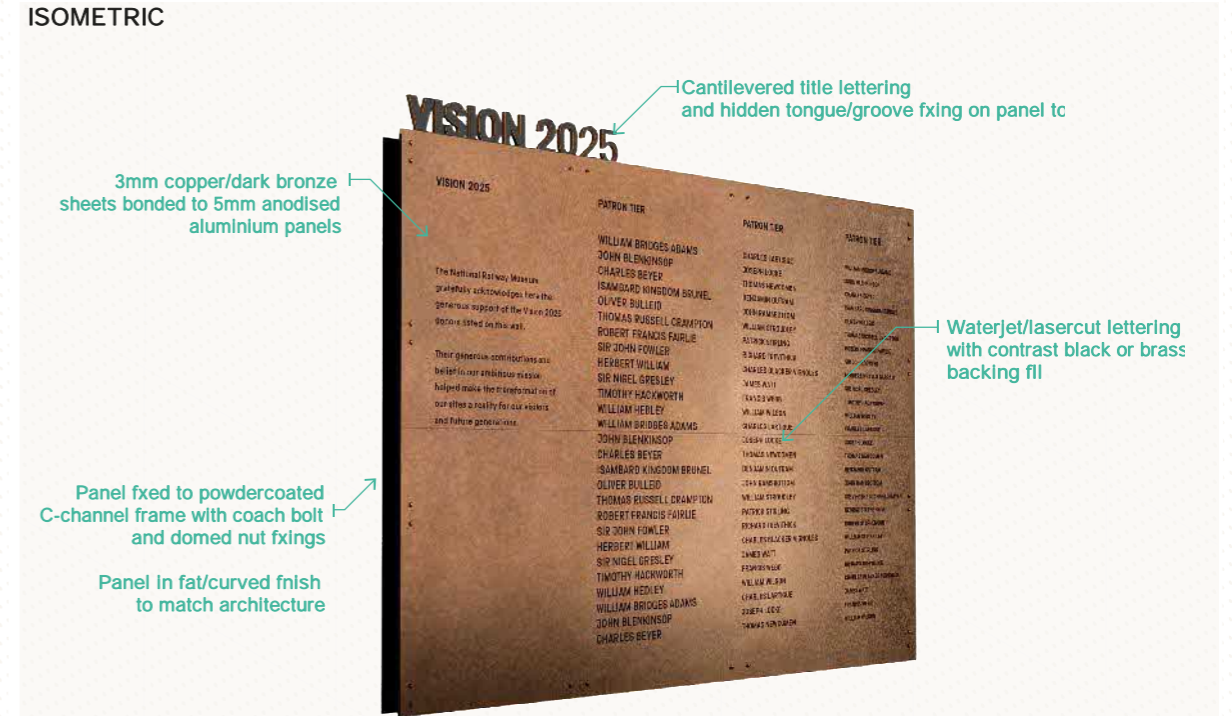

DNA

*Donor Recognition (Vision 2025)*

Recognises the supporters of the transformation of the sites.

- Dimensions :** 2000 x 1540 x 100 mm (panel) and 1000 x 130 x 10 mm (cantilevered lettering)
- Specifications :** 3mm copper/dark bronze sheets bonded to 5mm aluminium panels  
Flat panel fixed to powdercoated C-channel frame with coach bolt and domed nut fixings  
Backing mount to suit wall surface (flat for Locomotion AND curved for Central Hall)  
Waterjet/lasercut lettering with contrast black or brass backing fill  
Cantilevered title lettering and hidden tongue/groove fixing on panel top

- Content :** Recognition
- Reading range :** 1.5-14 m
- x-Height :** 12.5, 15 and 20 mm (engraved lettering) and 90 mm (cantilevered title)
- Character limit :** 40-50 word introduction and ±80 donor names
- Additional:** Mounted at 0.65 m above F/L

**Note:** Central Hall requires curved backing mount variation (front to remain flat)  
Name on visual shown are for demonstrative purposes only

**RAL 9011**  
GRAPHITE BLACK  
Powdercoat aluminium frame and lettering

**AGED COPPER**  
Metallic finish with matt lacquer  
Background and fixings

ELEVATIONS

SHOWN @ 5% SCALE

DNA

*Design specification intent*



**UPDATED NOTE:**  
Vision 2025 lettering  
element to be removed  
from fabricated design



# VISION 2025

VISION 2025	PATRON TIER	PATRON TIER	PATRON TIER
50 (15mm)	26 (20mm)	33 (15mm)	41 (12.5mm)
<p>The National Railway Museum gratefully acknowledges here the generous support of the Vision 2025 donors listed on this wall.</p> <p>Their generous contributions and belief in our ambitious mission helped to make the transformation of our sites a reality for our visitors and future generations.</p>	<p>SIR NIGEL GRESLEY TIMOTHY HACKWORTH WILLIAM HEDLEY CHARLES LARTIGUE JOSEPH LOCKE THOMAS NEWCOMEN BENJAMIN OUTRAM JOHN RAMSBOTTOM SIR VINCENT LITCHFIELD RAVEN GEORGE STEPHENSON ROBERT STEPHENSON WILLIAM STROUDLEY PATRICK STIRLING RICHARD TREVITHICK CHARLES BLACKER VIGNOLES JAMES WATT FRANCIS WEBB WILLIAM WILSON PATRICK STIRLING RICHARD TREVITHICK SIR NIGEL GRESLEY TIMOTHY HACKWORTH WILLIAM HEDLEY CHARLES LARTIGUE JOSEPH LOCKE FRANCIS WEBB</p>	<p>CHARLES LARTIGUE JOSEPH LOCKE THOMAS NEWCOMEN BENJAMIN OUTRAM JOHN RAMSBOTTOM WILLIAM STROUDLEY PATRICK STIRLING RICHARD TREVITHICK CHARLES BLACKER VIGNOLES JAMES WATT FRANCIS WEBB WILLIAM WILSON CHARLES LARTIGUE JOSEPH LOCKE THOMAS NEWCOMEN BENJAMIN OUTRAM JOHN RAMSBOTTOM WILLIAM STROUDLEY PATRICK STIRLING RICHARD TREVITHICK THOMAS RUSSELL CRAMPTON ROBERT FRANCIS FAIRLIE SIR JOHN FOWLER HERBERT WILLIAM GARRATT SIR NIGEL GRESLEY THOMAS RUSSELL CRAMPTON ROBERT FRANCIS FAIRLIE SIR JOHN FOWLER HERBERT WILLIAM GARRATT SIR NIGEL GRESLEY FRANCIS WEBB WILLIAM WILSON CHARLES LARTIGUE JOSEPH LOCKE</p>	<p>WILLIAM BRIDGES ADAMS JOHN BLENKINSOP CHARLES BEYER ISAMBARD KINGDOM BRUNEL OLIVER BULLEID THOMAS RUSSELL CRAMPTON ROBERT FRANCIS FAIRLIE SIR JOHN FOWLER HERBERT WILLIAM GARRATT SIR NIGEL GRESLEY TIMOTHY HACKWORTH WILLIAM HEDLEY CHARLES LARTIGUE JOSEPH LOCKE THOMAS NEWCOMEN BENJAMIN OUTRAM JOHN RAMSBOTTOM SIR VINCENT LITCHFIELD RAVEN GEORGE STEPHENSON ROBERT STEPHENSON WILLIAM STROUDLEY PATRICK STIRLING RICHARD TREVITHICK CHARLES BLACKER VIGNOLES JAMES WATT FRANCIS WEBB WILLIAM WILSON PATRICK STIRLING RICHARD TREVITHICK CHARLES BLACKER VIGNOLES WILLIAM BRIDGES ADAMS JOHN BLENKINSOP CHARLES BEYER ISAMBARD KINGDOM BRUNEL OLIVER BULLEID TIMOTHY HACKWORTH WILLIAM HEDLEY CHARLES LARTIGUE JOSEPH LOCKE THOMAS NEWCOMEN WILLIAM WILSON</p>

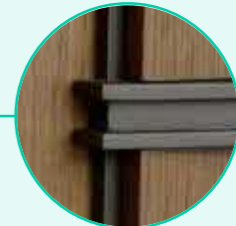

CONSTRUCTION  
AESTHETIC (EXPOSED  
C-CHANNEL SIDES)



CONTRAST FINISHES  
(METALLIC COPPER BONDED  
TO MATT POWDERCOATED  
ALUMINIUM BACKING)



LASERCUT ENGRAVED  
AND FILLED LETTERING

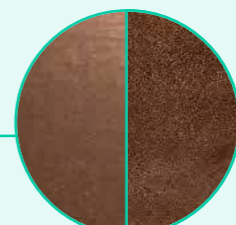

METALLIC FASCIA  
(COPPER/DARK BRONZE)



COACH BOLT AND DOME  
NUT FIXINGS (COLOUR  
MATCHED TO FASCIA)

SHOWN @ 7% SCALE  
VISUAL SHOWN FLAT MOUNT VARIATION



ELEVATIONS

SHOWN @ 7.5% SCALE



**DNX**

*Project Supporter Panel*

Recognises the project supporters for exhibitions.

**Dimensions :** 1200 x 400 x 10 mm (panel)

**Specifications :** 10mm opaque acrylic panel (Perspex® 962 or similar) with rounded edges  
 Printed graphics in opaque white  
 Matt satin laminate, with UV-resistant and anti-scratch coating  
 Mounted to wall using hidden fixings

**Content :** Recognition

**Reading range :** To match existing museum template

**x-Height :** To match existing museum template

**Character limit :** To match existing museum template

**Additional:** Mounted at 1.2 m above F/L

**Note:** Panel to match existing museum product shown in photo above

**RAL 9003**  
 SIGNAL WHITE  
 Printed graphics on  
 vinyl backing

**PERSPEX**  
 BLACK 962  
 Background colour



## Quality, performance and care

The following pages describe the expectation criteria for each sign type, in terms of its materials, application methods and craftsmanship, to ensure that all signage manufactured and installed are suitable to meet the demands and usage of the museum, its visitors and environment, as well as criteria to ensure products are able to be maintained by staff, rotation of care and lifespan of products.

The information provided offers recommendations for guidance only from Mima Group. The Nominated Sign Contractor will be responsible for the final quality of the manufacture and installation of the Signs.

The Nominated Sign Contractor must review the technical drawings and details provided in this document, and produce their own fabrication drawings to closely resemble the design intention and finish of these designs, and provide final specifications, including any foundation, components, construction and mounting details or diagrams as required. All final construction drawings must be submitted for client approval before manufacture.

The supplier may propose substitutions or modifications to the design intention and specification, with assurances that can be approved by the client. Any substitutions or modifications must be done in consultation with Mima Group ahead of seeking any client approval. Please refer to the *Standards and Workmanship* for more information.

### General

#### About these criteria

These are the 'Performance Criteria' (the 'Specifications') for 'National Railway Museum' and Locomotion Wayfinding' (the 'Signs').

Specifications here must be read in conjunction with the Detailed Design Specifications (the 'Drawings') the Specifications and Drawings together form the Visual and Performance Package which must be adhered to as a strict guide for the purposes of Tender, Manufacture and Installation so that the Sign is as intended.

The Visual and Performance Package should be complied with only in so far as they do not conflict with any statutory or regulatory requirements. In the event of any such conflict, the Sign Contractor must immediately notify the client team. It is the responsibility of the Nominated Sign Contractor to notify the client team of any guidance contained within this document with which they cannot comply. Notification must be made, in writing, at time of Tender submission.

It is the responsibility of the Sign Contractor to use materials, components and construction

methods such that the finished Sign is safe to all parties in any predictable situation for the lifetime of the Sign.

All Signs are to be manufactured and installed suitably for the application for which they are intended using best practice in terms of design, materials, construction and installation.

Any deviation from the Visual and Performance Package will only be considered during the post contract detail development phase of the project (i.e. prior to actual production) and will only be included once approval is granted in writing by the client team.

No additional costs will be considered to meet the requirements stated in the Visual and Performance package, as provided at time of Tender, unless agreed specifically in writing by the client team.

A very high quality of workmanship shall be provided to ensure that the final appearance of the Signs is of a uniform and high quality. All signs are subject to approval of prototypes to set standard of quality prior to manufacture.

### Standards and workmanship

#### Regulations and compliance

In undertaking technical design, manufacture and installation of the Signs, the Nominated Sign Contractor must comply with all current and applicable national, statutory and legislative requirements.

The signs are to be designed, manufactured and installed following national standards and any referred standards therein. This includes compliance with requirements of the following where appropriate:

- calculating effects of wind pressure on signs
- for all sealants, coatings and varnishes, including UV, weather and rust-proofing

Signs and work on sign installations shall also comply with international legislation. The Nominated Sign Contractor must ensure that all aspects of the technical development and manufacture of the signs (materials, finishes, manufacturing details etc.) are fully compliant with ICC A117.1 and Equalities Act: 2010.

#### Quality and appearance

A very high quality of workmanship shall be provided to ensure that the final appearance of the Signs is of uniform and high quality.

In principle, various components' sizes, shapes and details are indicated in drawings. If, in connection to strength calculations, insulation requirements, manufacturing processes or otherwise, the Nominated Sign Contractor deviates from the design intention stipulated, then they must ensure that the final appearance is similar to the design intent indicated on drawings and that any modification is to the satisfaction of the client. All final sign dimensions are subject to a complete site survey by the Nominated Sign Contractor.

Allowance for visits to survey should be included and itemised in the Tender. Extreme care and caution must be exercised and shown while working in historical buildings or conservation areas to reduce harmful impact or damage in these areas of significance.

### Construction and installation

Extreme caution must be exercised and shown the utmost respect while working in the historical buildings at the site to avoid causing any damage.

All panels and surfaces are to be designed, manufactured and installed to be horizontally and vertically true unless stated otherwise. The tolerance for such a requirement at installation is 1mm over any given length. Ensure correct and accurate alignment of all panels when installed onto the Signs –within the stated permissible tolerances.

All adhered graphics and vinyls must be applied on surfaces clean of grease or dirt, in favourable, non-contaminated rebate, ensuring no air pockets. Cut elements must be applied horizontally or vertically true, respecting any spacing of the original artwork, and ensuring signs are consistent accessible datum.

All joins must be even and consistent with no visible gaps (i.e. no views in to sign interior). No hand gaps or finger traps are to be present in Signs. All edges must be sealed and profiles rounded over to minimise scratches or catching.

Any internal structure or framing must not be visible or have external visual impact. All parts of the Signs must be securely fixed with no movement or rattling and in such a way as to prevent removal by unauthorised persons.

Frameworks where exposed, are to be finished to the same high quality as other parts of the Sign Framework.

Fixings should be hidden unless indicated otherwise and must not interfere visually with the graphics. The Nominated Sign Contractor will be responsible for selecting fixings suitable for their intended purpose and being adequate to comply with the requirements stated in the specifications and match the design intent.

Sealants and varnishes must be applied following manufacturers' instructions. All Sign faces are to be finished to equal high standards.

All materials, coatings, finishes and adhesives must be UV-, thermo-, and dimensionally-stable for the climatic conditions. Elements that may be subject to thermal expansion must have appropriate tolerances applied.

### Sustainability

The contractor ensures that care is taken to choose materials, products and application methods that offer the highest environmental standards, where appropriate, including waste materials disposal.

### Technical drawings

The Nominated Sign contractor is to supply technical drawings of all Signs for client team approval prior to manufacture commencement.

### Prototyping and testing

Before the production roll-out of Signs, it is advised that test samples of printed, painted, anodised and adhesive elements should be submitted to the client for approval.

It may be recommended that fully functioning prototypes be produced of sample products at the actual scale for on-site testing. It is advised that the Nominated Sign Contractor inspect and conduct a ground survey of each location before sign installation.

All Signs are to be installed with a supervisor ensuring guidelines are checked and adhered to. Any problems during installation must be flagged immediately, and the client team notified. Protective coverings should be used over signs until the client approves the installation. Refinements to the prototype may be required if test outcomes fall short of acceptable levels.

### Artwork and fabrication

Always use the electronic artwork supplied originally by Mima Group. All Artworks must follow the guidance provided by the client team. It is the Sign Contractor's responsibility to produce production artwork for checking by the client team prior to production. Any Signs containing artwork not explicitly approved by the client team may require replacement at the Nominated Sign Contractor's cost.

### Inspection

The client team are to be permitted to review all Signs during production and to inspect for quality of workmanship and quality control.

The Nominated Sign Contractor is to provide photographic images of prototypes during key stages of construction to the client team for partial inspection. The client team may conduct a final Sign quality control review of fully assembled and operational Signs before leaving the factory. This should be conducted well in advance of any installation date to enable any defects to be rectified without impact upon the installation date.

### Risks and guarantees

Where required, guarantees for components must apply from when the component is ready to be delivered or during a specified period start date period. The responsibility of developing calculations, shop drawings, manufacturing and implementation, shall remain with the Nominated Sign Contractor.

The Nominated Sign Contractor is responsible for developing all connections. Connections shown on drawings here are only indicative. The weight, quantity, and size of connections shall be determined by the Nominated Sign Contractor for approval by Design Consultant.

## Specifications criteria

### Materials

#### Metals

A minimum 10-year lifespan is expected for all metals, based on site-specific conditions defined by the sheet supplier.

All sheets must be of suitable minimum depth for rigidity, able to withstand damage or warps. Sheets may be seamlessly bonded to strengthen. Sheets and panels must have any edges and corners rounded over to reduce sharpness.

Elements subject to climatic thermal expansion must have appropriate tolerances applied.

Aluminium sheets must be powdercoated, colour-matched to the approved specification, and anodised (cost-dependent) when specified for use externally or as building identification.

All stainless steel cut lettering should be cut, powder-coated, and colour matched to the approved specification. Steel dibond must ensure it is constructed with a black foam core and sealed along all edges.

Copper finishes shall be fabricated to a shade approved by the client team, and treated or lacquered to stabilise. Copper surface is to appear slightly textured and matt in finish.

Colours shall be matched to the colours specified in the drawings. Unless specified otherwise, all visible components must be colour-matched to the Sign face.

Consistency and uniformity of colour, finish and coating shall be such that no visible difference can be identified across the range of products on site. Any variation in uniformity that may conflict with this requirement must be determined and demonstrated at Tender stage.

Protective coatings are recommended for all external Signs that can reduce glare, are UV-resistant, non-scratch and anti-graffiti.

Any other suitable or more appropriate method should be suggested in writing with any cost variation, at time of Tender submission.

Any coating used should be applied as per the manufacturers' instructions and, at a minimum, to the relevant national standards. Any coating must be suitable for the substrate it is being applied to and for the intended purpose of the Sign.

A minimum of 10 years guarantee is required for all powdercoated finishes, coatings and sealants, based on site-specific conditions defined by the paint or sealant manufacturer.

Complete copies of the manufacturers' guarantees shall be provided prior to production.

Manufacturers should provide suppliers with data sheets and warranty information to confirm the design life of the finishes.

Damage repair is to be undertaken on-site with prior agreement of the client team. Any repairs shall be to the same standard as the original finish, with no noticeable visual impact and shall carry the same guarantee as the original.

#### Paint

Paint medium must be suitable for the substrate it is applied on to and to its climatic conditions. Paintwork must have a 10-year min. lifespan, high lightfastness rating and matt or satin finish.

All paintwork must be even and consistent, in colour and finish, with no gaps, blemishes or damage. All paints must precisely match the colour benchmarks given for the appropriate lighting conditions. Paint should be of matt or satin finish and not cellulose-based.

All surfaces must be adequately prepared prior to paint application as instructed. Any protective overlays must be removable without need for tools or solvents, and without leaving marks.

Stencilled lettering must match the artwork supplied to ensure correct spacing. Any cut lettering must be removable without specialist tools or solvents, and without leaving marks.

All lettering must be applied vertically and horizontally straight, respecting spacing.

#### Plastic (FOREX® or similar)

All plastic finishes should be matched in colour, and sheen to the Sign face, and dimensionally-stable to withstand climatic conditions and sealed across all edges and be recyclable.

#### Veneer laminates (ABET LAMINATI or similar)

A selection of suitable veneer finishes must be provided by the Nominated Sign Contractor, in either black aluminium or dark wood, for final selection and approval from the client team. Laminated veneers are to be durably bonded to furniture substrate using a suitable 3M adhesive VHB tape, respecting spacing set in Artwork.

#### Vinyl

Vinyl will be 3M 100 series opaque matt finish vinyl as a minimum standard, or similar. Vinyls must have 10-year minimum lifespan. The manufacturer's instructions for application are to be used to ensure longevity. Digital print should be high quality, with samples required.

#### Wood

All wood materials should be constructed of lightweight Birch Plywood, unless specified differently and be FSC-certified. All woods must be protectively varnished with matt seal.

### Finishes

#### General

All final sign dimensions are subject to a full site survey by the Nominated Sign Contractor. Allowance for surveys must be itemised in Tender.

All materials and finishes must be demonstrated to be of acceptable quality. All finishes shall be stable, fade-resistant, and unaffected by UV light within the design life of the products.

All finishes shall be of uniform texture, colour and finish and be resilient to all known and/or specified environmental and pollution effects. No blisters, scratches, flow lines, streaks, or other visual defects shall be allowed.

All welds in visible locations to be seamless. No visible fixings are allowable unless specified by design or approved by the client team in cases where the Nominated Sign Contractor can prove it is not possible to achieve. All laser cut edges to be finished smooth –no sharp edges.

The Signs should be detailed and manufactured to be inherently vandal-resistant, as far as is practically possible, all common or anticipated methods of vandalism (including scratches). Any Signs or components expected to receive high levels of damage must be designed with a capability for replacement of the Sign or associated.

All visible areas including components, to be free of scratches, distortions, blemishes, dirt, grease and marks upon completion of installation or removal of protective wrapping and packaging (whichever is the later) when viewed from a distance of 1 meter for wall and ground-mounted signs and 4 metres for architectural letters.

Any Signs or Sign components damaged during the process of installation are to be removed and replaced with the prior agreement of the client team. Unless otherwise stated, the Sign faces must be completely flat and rigid in predictable situations. Panels must not deflect or distort under wind loading or physical pressure. All visible flat surfaces are to be of one panel with no breaks or seams unless specified differently or if standard sheet sizes demand otherwise.

#### Die-/Fret-cut graphic lettering

Standalone lettering is to be cut from sheets and bonded to suitable backing for rigidity and depth, ahead of mounting. Lettering to be powdercoated and colour matched to specifications, and where specified anodised.

Lettering face must show no impression of bonding to backing, and methods for mounting and fixing must appear hidden or concealed through colour-matching finishes. Final lettering must be stable and not deflect or distort under wind loading or physical pressure.

The Nominated Sign Contractor is responsible for ensuring the final mounted product can achieve a minimum 10–or 25–year lifespan.

#### Etched and engraved graphic lettering

Engraved graphics will be created either through acid-etching OR high-resolution waterjet/laser-cutting to be defined alongside the production of technical detailing for bespoke products. Lettering is to be filled with resin or raised.

#### Raised graphic lettering

Where applicable, raised character signage must be completed with ICC A117.1 (raised 0.8mm, with a cap height of 16mm minimum per 6 feet reading distance). It is advised that test samples of printed elements be submitted for client approval before manufacture.

#### Sealants, coatings and varnishes

Protective coatings, sealants and varnishes are used across the Sign product suite, to prevent or reduce decay, damage or change either via heavy usage, climatic conditions, maintenance or vandalism of the Sign throughout its lifespan.

All materials should have exposed faces sealed, powdercoated or lacquered in matt (or as close to) finish. Gloss and mirrored finishes that can produce glare will not be accepted.

### Fabrication and Application

#### Adhesives

All adhesives should be UV-, thermo- and dimensionally-stable to climatic conditions. Where adhesive tape is specified, 3M 100 VHB tape is recommended as a minimum standard, cut to fit and concealed. The Nominated Sign Contractor must ensure that all adhesives used are appropriate to substrates being adhered to, and that bonds are resilient to touching, cleaning and climatic conditions.

Adhesion should be consistent edge to edge with no air bubbles or blistering. Application methods to follow manufacturers' instructions.

Unless otherwise specified, self-adhesive vinyl on the glass will be reverse printed with opaque matt finish and applied to reverse face of glazing.

#### Components

All finishes on sign components shall be durable, of uniform texture, colour and gloss level and resilient to known/specified climatic conditions, and must be demonstrated as acceptable quality.

All surfaces to be designed, manufactured and installed horizontally and vertically true unless stated otherwise. At installation, the tolerance for such requirement to be 1mm in any length.

Framework, where exposed, to be finished to the same high quality as other parts of the Sign.

All visible flat surfaces to be of one sheet panel with no breaks or seams unless specified, or standard sheet sizes demand otherwise.

The Nominated Sign Contractor must ensure correct/accurate alignment of all components when installing Signs –within stated permissible tolerances. All joins must be even and consistent with no visible gaps, and no movement or rattling in any parts of the Sign, and must be securely fixed preventing unauthorised tampering.

Where applicable, internal structures/framing must not be visible or have any visual external impact. No light leakage is permissible.

No hand gaps or finger traps to be present in the Signs. Any specified shadow gaps must be of constant and even thickness and depth, as to meet the visual requirements as specified.

#### Fixings

The Nominated Sign Contractor will be responsible for selecting fixings suitable for the fixing substrate and adequate to comply with the requirements stated in the Specifications, and have adequate protection against any corrosion likely to occur in their position of use is provided for the service life specified.

All fixings to remain secure and shall conform to all statutory requirements regarding strength and type. Adequate measures shall be taken to

prevent bi-metallic corrosion between dissimilar metals and to isolate aluminium components from cementitious surfaces.

All fixings shall be of adequate strength for their designed purpose fitted to an appropriate torque, and manufactured from a corrosive resistant material, unless specified otherwise

Any fixings subject to loosening due to vibration/movement shall be provided with extra security by way of a mechanical locking method (e.g. locknuts) or appropriate engineers adhesives.

All VHB tape to be 3M 100 as minimum standard.

The method of fixing shall not damage anything being fixed or anything receiving fixings other than the fixing/installation points.

Where fixings are visible, these shall be colour and aesthetically pleasing to match/suit and minimise visual impact to the items being fixed.

The top face of all Signs are to be the same high standard of finish as the other Sign faces, with fixings, where required, are preferred to be located on the non-visible under-side or top face.

All fixings used for maintenance and repair access must be hex-socket heads (at a size to be agreed) unless mechanical requirements dictate otherwise (in which case approval must be obtained) and unless easily accessible (in which case security fixings must be used).

Removable items that require access or removal shall use fixings retained into the sign or panel. These fixings should not be of a self-tapping type, but should use appropriate threaded inserts, tapped metal or removable threaded parts such as nuts.

Rivets and any other non-removable fixings are not acceptable where removal or replacement of that associated Sign component is likely.

#### Modelmaking/3D printing

Extruded elements must be constructed of durable material suitable to heavy use and climatic conditions. Any bonds must be seamless and hidden and durable. Extruded elements may be 3D printed or mould-made (cost dependent), with prototype sample produced ahead of manufacture for approval by the client team.

The Nominated Sign Contractor should ensure all elements are UV-stable, thermo-stable and dimensionally stable for the climatic conditions, prepared and built externally prior to installation, and able to achieve a 10-year minimum lifecycle.

#### Mounting

The Nominated Sign Contractor is responsible for developing appropriate mounting details and any bespoke fixings across the site.

Any connection bars or frames, particularly for lettering must be stable, resilient and discrete.

Appropriate calculations will be undertaken before construction to ensure all roof/wall/ceiling/ gate/post/floor mounted Signs fixings and foundations are sufficient for environmental conditions such as wind loading.

Where possible, mounting/fixing must match the Specifications intent provided. Should the Nominated Sign Contractor advise differently this would require prior written confirmation.

#### Printed and painted graphics and lettering

All paintwork and print are to be even and consistent, with no holes, blemishes or damage, and applied horizontally and vertically straight and true, at consistent datums.

Where Signs are accessible, protective finishes are recommended against vandalism.

Print and painted applications must be suitable for surfaces and substrates, and UV-, thermo- and dimensionally-stable in climatic conditions, across the specified lifespan of the Sign.

All colours must precisely matched to colour benchmarks given for the appropriate lighting conditions. The paint and print colour should match consistently. Glossy finishes should be avoided, with matt finishes and laminates advised.

All printed inks must be solid, without streaks of marks, opaque and UV-stable and suitable for substrates when printing direct to media.

All surfaces to be prepared before application as per manufacturer's guidelines. Any protective films or tapes used must be low-tack and possible to remove without tools, solvents or cleaning solutions, and without leaving any marks on visible surfaces.

All printed applications require a minimum 5-10-year lifespan dependant on where it is used, and based on site-specific conditions as defined by the paint/ink supplier.

### Structural engineering and foundations

The structural design of any steelwork and foundations shown here are indicative. The Nominated Sign Contractor must review the design and carry out structural checks and certification of the final design to comply with local legislation, and can suggest alternative foundation types.

Site surveys must be carried out to ensure the final foundation design does not impact underground services.

Care must be taken by the installer to ensure a neat junction between the finished floor materials and the sign structure.

### Structural framework

Galvanised low-carbon steel, aluminium or stainless steel internal frames are acceptable for external Signs, as long as the structural integrity and aesthetic intent are guaranteed.

It is the responsibility of the Nominated Sign Contractor to review the design intent, and carry out structural engineering calculations for approval –clarifying the tolerances given by the selected materials and fixings.

Interior Signs that require wood or similar internal structural frameworks, must be encased in powdercoated metal, so that no wood is visible.

All materials, coatings, finishes and adhesives should be UV-stable and dimensionally stable for climatic conditions. Elements that may be subject to thermal expansion must have appropriate tolerances applied.

The manufacturer must ensure that coatings are applied in line with suppliers' best practice guidance and that specific care is taken to minimise any damage to the coating. Any damage to the coating must be minimised and touched-up. This includes exposure of the mild steel caused by on-site cutting, drilling or other abrasion and the use of fixings that penetrate the coating.

All steel must be sandblasted, and outer corners demurred. Base plates must be hidden unless otherwise stated. All visible hardware must be powdercoated and colour-matched to the detail specifications unless specified otherwise.

### Welds and joinery

All visible welds must be continuous and cut flat; no intermittent chain welds are permitted. All holes for the galvanising process should be marked on a construction drawing.

All visible parts, plates, and sections must be precision cut (no 'shear cutting').

### Maintenance and care

#### Caring for metals and plastics

Metal surfaces should be handled wearing cotton microfibre gloves (or similar) to avoid fingerprints or smudges.

Dry cleaning must be avoided when cleaning signage to prevent surface scratches or damage. Mechanically blow all surfaces to remove loose debris before cleaning.

A mild solution of washing up liquid (or equivalent cleaning agent) with lukewarm water is advised to avoid scratches and/or corrosion of surfaces, finishes and bonding.

Following cleaning, surfaces should be manually polished off using a lint-free cloth (or similar).

#### Caring for vinyls and veneers

When cleaning vinyl graphics are applied on to glazing cleaner designed for high-quality painted surfaces. The cleaner must be wet, non-abrasive, without solid solvents and have a pH value between 3 and 11 (neither strongly acidic nor strongly alkaline). Rinse thoroughly after cleaning and dry with a soft cloth or rubber squeegee to avoid water spots.

Note: cleaning a vinyl or veneer applied on to solid substrates internally should be gently wiped with a soft, lint-free dry cloth to remove any dust.

#### Access

All Sign components should be accessible for ongoing maintenance, or changing of graphical components. The design of the Signs must allow easy access for maintenance of all external and internal components.

Panels and components must be easily replaceable in the event of damage.

So far as is practically possible, maintenance access shall be made possible without involving the disproportionate dismantling of parts or making adjacent areas unavailable.

Access for maintenance and repair should only be with use of appropriate professional tools. There should be minimal visible interference from such access features. All fixings must be hidden or tamper-proof to prevent vandalism.

The Nominated Sign Contractor is to consult the client team for approval of the proposed methods of access prior to manufacture.

#### Maintenance schedule

A monthly visual inspection is recommended to check for surface scratches, sign-face damage, graffiti, structural damage and non-standard signing due to operational updates etc.

Checking and removing dust building with a vacuum cleaner or similar monthly sign cleaning is recommended, as well as quarterly: of exterior surfaces and supporting structures.

Replacement parts (hardware, mechanical fasteners) are recommended to be kept in stock for quick maintenance or repair should the need arise. A disposal procedure is recommended to determine which obsolete elements can be removed, reused or discarded and how.



## Location Plans

The following pages show the placement and type of wayfinding products across Locomotion, following the most recent site visit.

Products shown on plan have a unique reference code, which can be used to in the schedule to ascertain content captured on each sign face where applicable, as well as further details about the product type itself.

**Note:** final sign locations are subject to change, and may require confirmation as sites develop.

**[LOC].[ZN].[8].[CAT].[PRD].[FX].[888]-[NSEW]**

site	zone	level	category	product	fixing	ref code	sign face orientation
Location			category		product		
LCM	Locomotion		<b>DIR</b> Directional			bes	Bespoke
			<b>DON</b> Donor recognition			<b>DN*</b>	Donor Recognition
zone			<b>ID*</b> Identification			<b>PN*</b>	Panel
HS	Historic Shildon		<b>INF</b> Information			<b>RD*</b>	Road Sign
MH	Main Hall		<b>MAP</b> Orientation			<b>ST*</b>	Stencil
NH	New Hall		<b>STT</b> Statutory			<b>TOT</b>	Totem
RT	Shildon Rail Trail					<b>VN*</b>	Vinyl
SH	Station Hall		fixing				
UR	Urban Realm		<b>AP</b> Applied				
			<b>FM</b> Fixed mount				
level			<b>FS</b> Freestanding				
0	Internal		<b>FX</b> Fixed other				
X	External		<b>PJ</b> Fixed projecting				
			<b>XX</b> Other				

\* type variation, e.g. size/use

# Location plans Locomotion

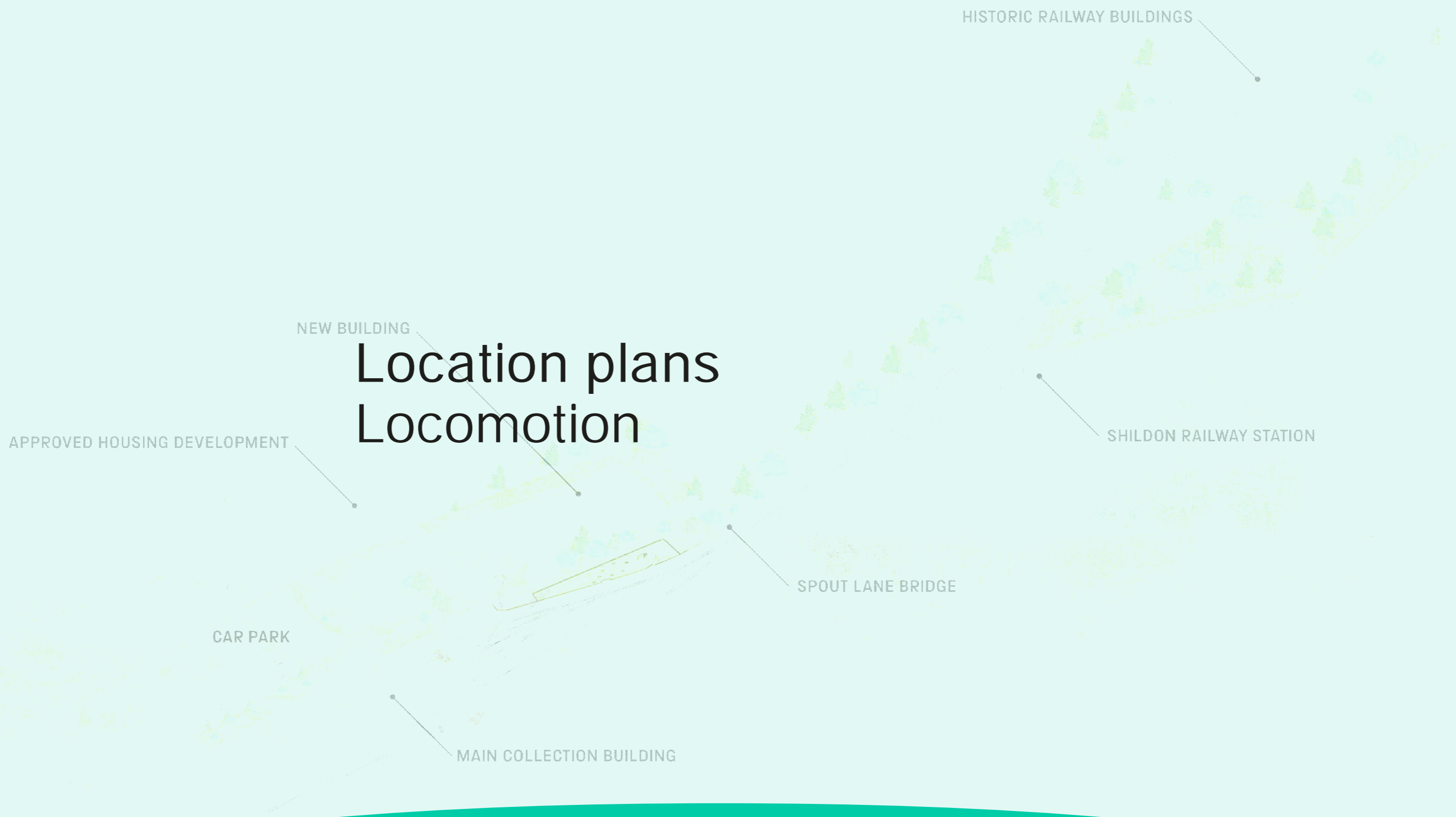

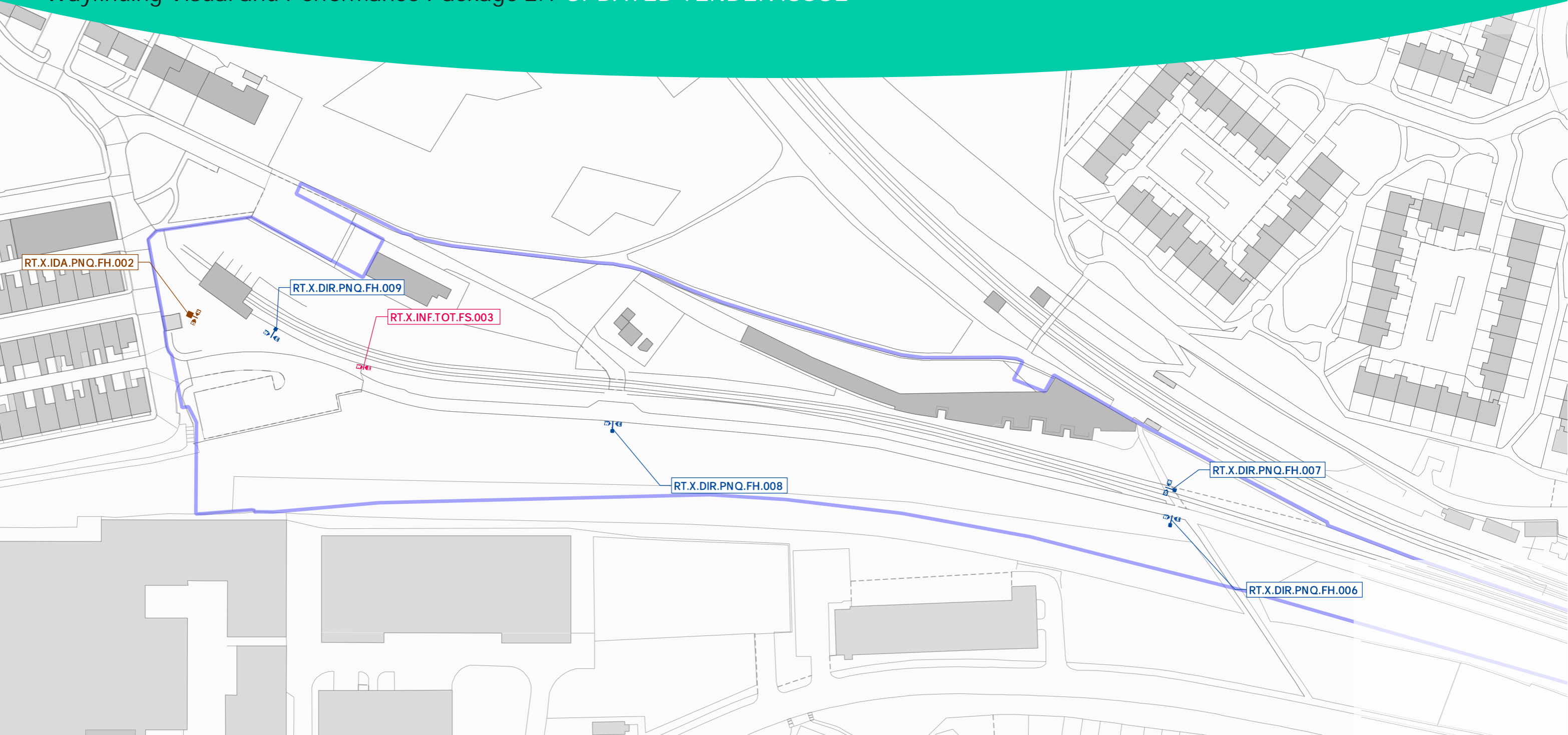

RT X HISTORIC RAIL TRAIL

LEGEND

- DIRECTIONAL  
PNQ : HANGING PANEL (SQUARE)
- IDENTIFICATION (ARRIVAL)  
PNQ : HANGING PANEL (SQUARE)
- INFORMATIONAL  
TOT : INFORMATION TOTEM (ONE SIZE)



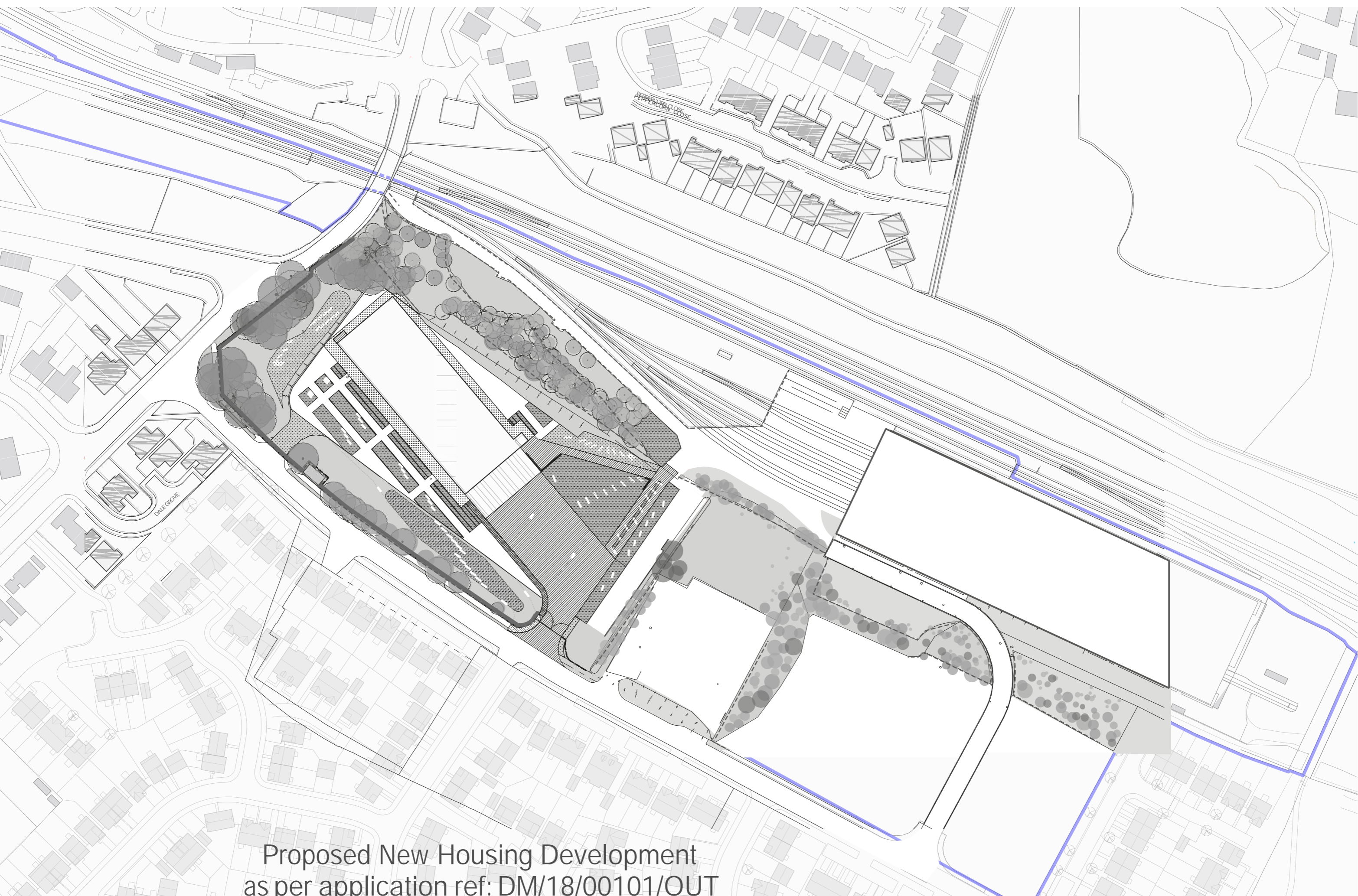

Proposed New Housing Development  
as per application ref: DM/18/00101/OUT

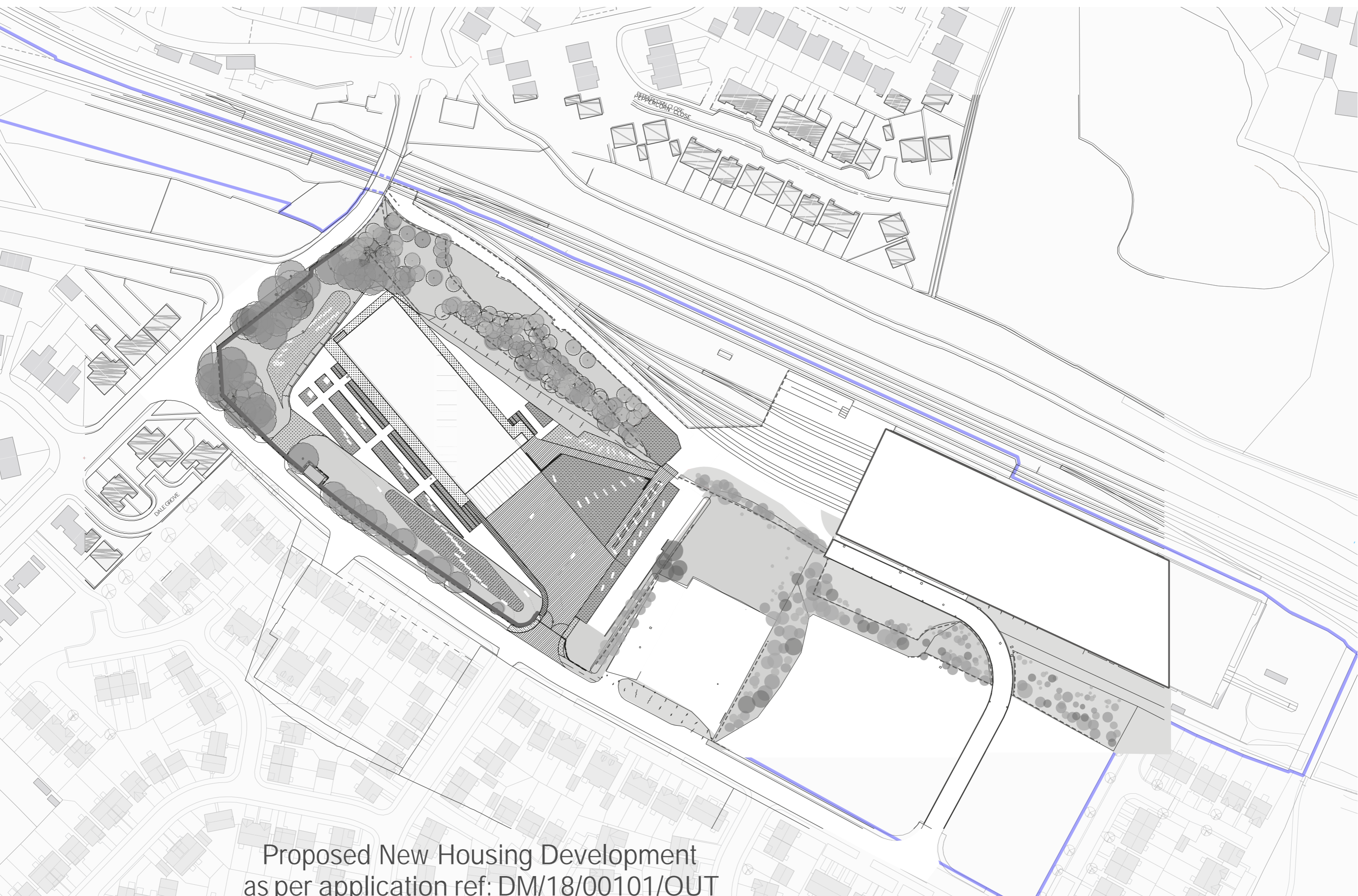

Proposed New Housing Development  
as per application ref: DM/18/00101/OUT

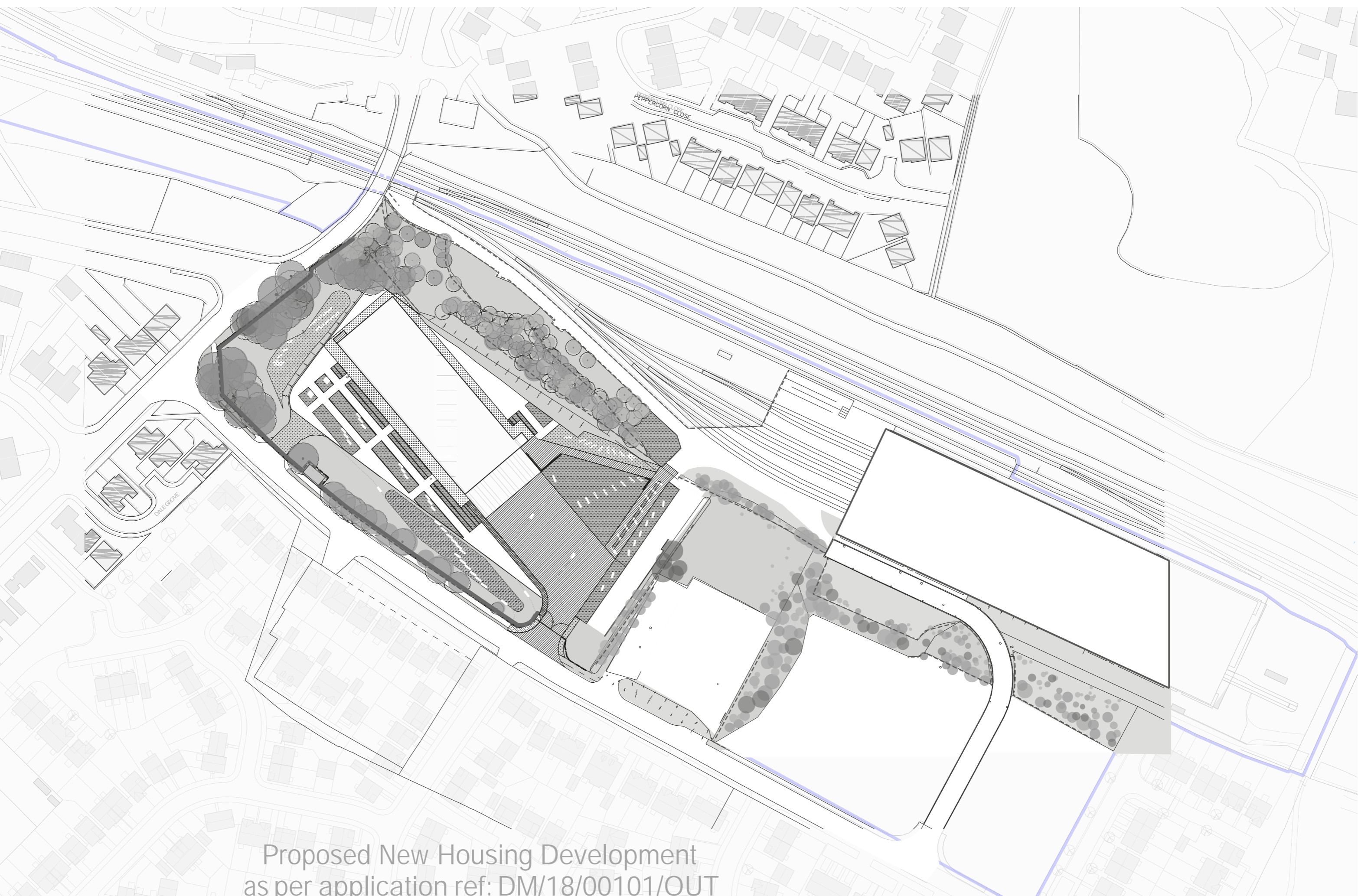

Proposed New Housing Development  
as per application ref: DM/18/00101/OUT

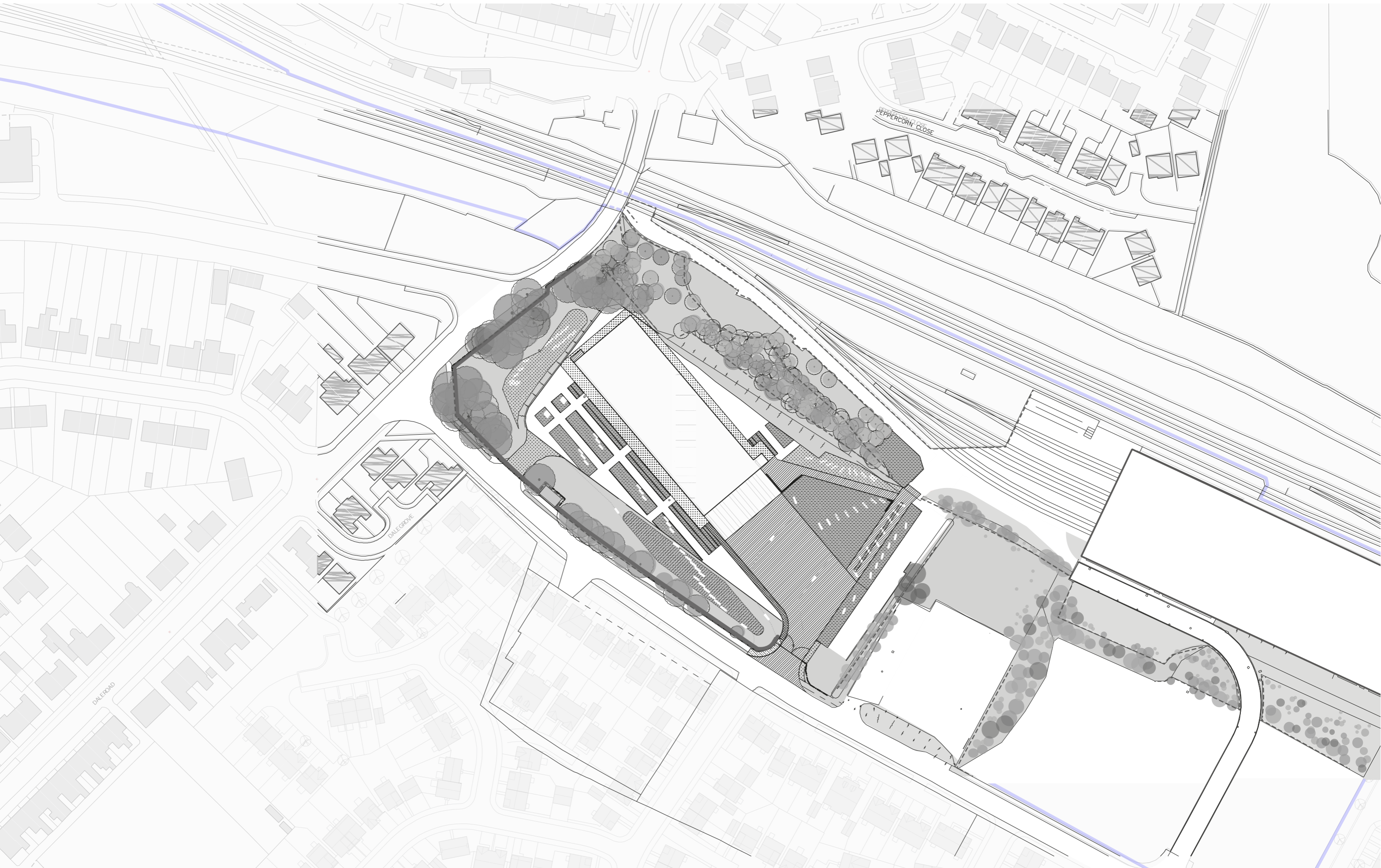

PEPPERCORN CLOSE

DALE GROVE

DALE ROAD

Proposed New Housing Development

15/01/2021/CHT

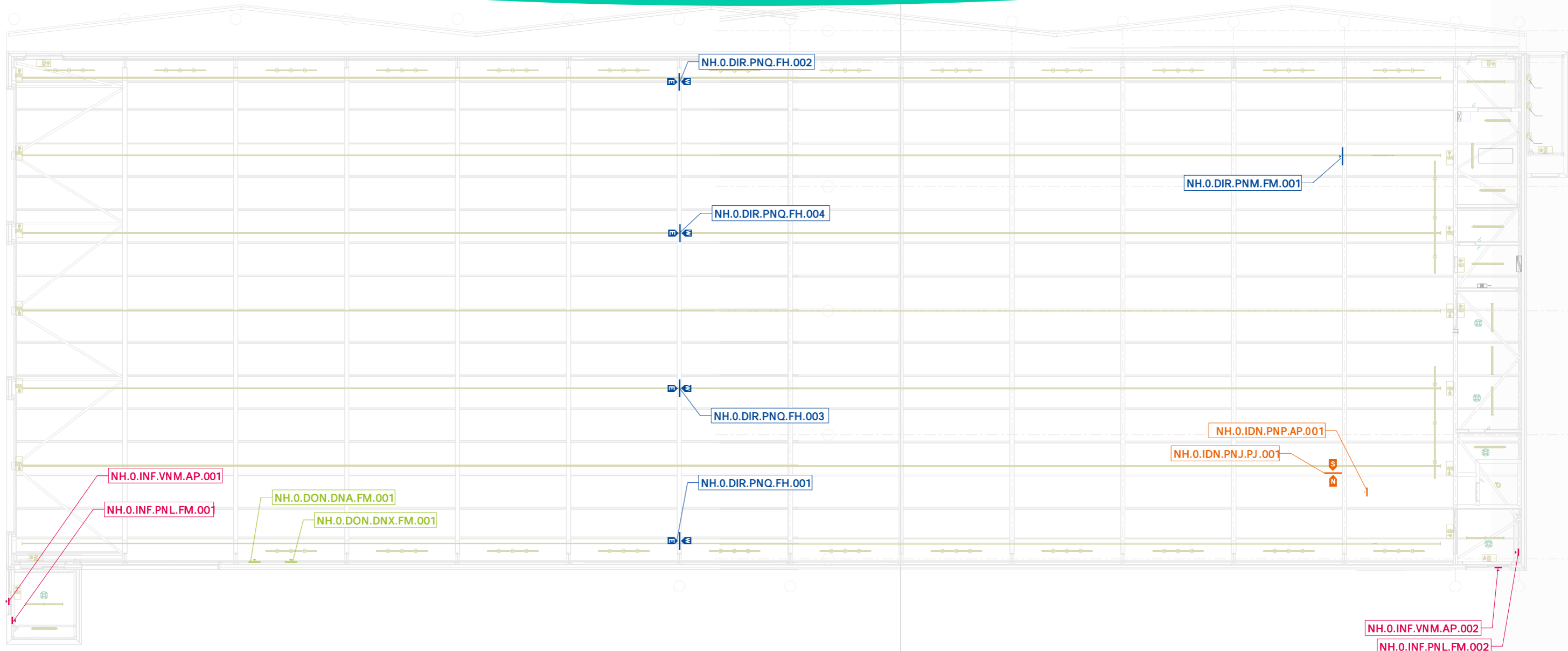

NH 0 NEW HALL (GROUND)

LEGEND

- **DIRECTIONAL**  
 PNM : FIXED PANEL (MIDI)  
 PNQ : HANGING PANEL (SQUARE)
- **IDENTIFICATION**  
 PNJ : PROJECTING PANEL (ONE HEIGHT)  
 PNP : FIXED PANEL (PICTO)
- **INFORMATIONAL**  
 PNL : PANEL (LARGE)  
 VNM : SELF ADHESIVE VINYL (MIDI)
- **DONOR RECOGNITION**  
 DNA : VISION 2025 BOARD (BESPOKE PANEL)  
 DNX : PROJECT SUPPORTER (ACRYLIC PANEL)



1:1250



## Supporting Information

The following pages detail the signage bill of quantities per site, and include a breakdown per zone (useful for phasing), and concludes in the signage schedule of each sign referenced on location plans: detailing the type of sign product, its specifications and content on each face.

Kindly note, some small variance in signage quantities may occur as the sites continue to evolve (further bespoke items however, will not be added beyond what is shown). For the purposes of tendering, the information shown is an accurate representation of what is anticipated based on what is known at this time.

**BILL OF QUANTITIES : LOCOMOTION**

This bill of quantities provides shows the overall signage required for the site, and is includes a breakdown per zone.

**Note:** quantities may vary slightly as the site evolves, but no further bespoke items will be added.

**Overall :**

OVERALL			
QUANTITY	PRODUCT TYPE	W x H x D (MM)	SPECIFICATIONS
1	DNA Vision 2025 Board	2050 x 1670 x 100	Cantilevered cut powdercoated aluminium lettering mounted on top of panel. ±80 names waterjet/lasercut with contrast fill OR Acid etched on panel front. Panel constructed of bonded copper sheet front to powdercoated aluminum backing, with C-channel frame, to be mounted on to flat and curved all surface with coach bolt/domed nut fixings. Matt lacquer to seal colour and finish.
1	DNX Supporter Panel	400 x 1200 x 5	Printed self-adhesive vinyl backing to clear acrylic panel, with copper top and bottom fr and domed bolt fixings, Antiglare, Antiscratch and UV resistant.
1	BES Tactile lec. map	1500 x 800 x 1130	Mixed material map (3D print or similar) w/ lasercut/extruded graphics + blocks. Durable bonds required for extruded elements to withstand frequent use. Tilt-mounted on powdercoated lectern plinth with coach bolt/domed nut fixings. Antiglare, Anti-scratch, UV-water-resistant.
3	STX Stencil Graphics X Big	±7100 x 900	Cut lettering (Painted/Powdercoated Aluminum/SAV Vinyl) to suit surface substrate
1	STG Stencil Graphics Giant	±14000 x 1800	Painted stencil lettering (external paint to suit surface) OR cut vinyl applied to glazing
3	STH Stencil Graphics Huge	±2000 x 245	Painted stencil lettering (paint to suit surface substrate)
2	STE Stencil Gr. Entrance	±1395/±2150 x 525	Painted stencil lettering (paint to suit surface) OR cut vinyl to back of glazing
2	VNM Vinyl Midi	615/900 x 200/700 x 1	Self-adhesive opaque cut vinyl (3M) . Applied on reverse of glazing (glue on front).
2	VNW Vinyl Welcome	1970 x 940 x 1	Self-adhesive opaque cut vinyl (3M) . Applied on reverse of glazing.
1	BJL Barrier Jacket	3901 x 2100 (1300 face)	PVC Tightly woven mesh 330gsm with concealed eyelet fixing along bottom, Or Painted board with brace fixing
3	PNL Panel Large	510 x 510 x 5	Printed powdercoated aluminium OR steel dibond panel with black core/sealed edges. Hidden fixings colour matched to panel, and method to suit mounting surface (wall/post). Raised lettering for opening times. Antiglare, Anti-scratch, UV-water-resistant.
1	PNM Panel Midi	320 x 240 x 5/80	Printed powdercoated aluminium OR steel dibond panel with black core/sealed edges. Colour-matched coach bolt fixings to suit mounting wall surface. Antiglare, Anti-scratch, UV-water-resistant.
2	PNS Panel Small	240 x 240 x 5	Printed powdercoated aluminium panel with raised lettering for level directories. Colour matched coach bolt fixings, or to suit mounting surface (wall/post/glazing)
1	PNP Panel Petite	120 x 120 x 5	Raised lettering for opening times. Antiglare, Anti-scratch, UV-water-resistant.
1	PNJ Panel Projecting	180/300/420 x 180 x 80	Powdercoated aluminium panel, printed graphics, 3M adhesive backing to suit surface
1	PNG Panel Gate	±1700 x 1700 x 5	Folded powdercoat aluminium panel, printed graphics, coach bolt fixings to wall. Anodised powdercoated aluminium OR Steel dibond panel with black core/ sealed edges
11	PNQ Panel Square	580 x 580 x 80	Printed graphics and raised lettering for opening times. Hidden tamper-proof fixings to suit existing gate. Antiglare, Anti-scratch, UV-water-resistant
4	RDL Road Sign Large	1020 x 1020 x 5	Powdercoated folded aluminium panel and fixings suspended from existing beam/ceiling. Printed graphics on panels, and stencilled lettering and graphics on beam posts. Panel suspended by welded galvanised rods from existing beam post (external) OR by wire with ceiling anchor/stop (internal). Antiglare, Anti-scratch, UV-water-resistant.
4	TOT Totem	510 x 2000 x 150	Steel dibond printed panel with black core and sealed edges, mounted to posts. Antigliar Anti-scratch, UV-water-resistant.
38	TOTAL (WFS PRODUCTS ONLY)		
2	TOTAL (DON PRODUCTS ONLY)		
5	TOTAL (BES PRODUCTS ONLY)		

**Breakdown by zone:**

NH NEW HALL	
QUANTITY	PRODUCT TYPE
1	DNA Vision 2025 Board
1	DNX Supporter Panel
2	STX Stencil Graphics X Big
2	STH Stencil Graphics Huge
2	STE Stencil Gr. Entrance
2	VNM Vinyl Midi
2	PNL Panel Large
1	PNM Panel Midi
1	PNP Panel Petite
1	PNJ Panel Projecting
4	PNQ Panel Square
15	TOTAL (WFS PRODUCTS ONLY)
2	TOTAL (DON PRODUCTS ONLY)
2	TOTAL (BES PRODUCTS ONLY)

MH MAIN HALL	
QUANTITY	PRODUCT TYPE
1	STG Stencil Graphics Giant
1	STH Stencil Graphics Huge
2	VNW Vinyl Welcome
1	BJL Barrier Jacket
4	TOTAL (WFS PRODUCTS ONLY)
1	TOTAL (BES PRODUCTS ONLY)

UR URBAN REALM	
QUANTITY	PRODUCT TYPE
1	BES Tactile lec. map
1	STX Stencil Graphics X Big
1	PNL Panel Large
2	PNS Panel Small
1	PNG Panel Gate
2	PNQ Panel Square
4	RDL Road Sign Large
3	TOT Totem
13	TOTAL (WFS PRODUCTS ONLY)
2	TOTAL (BES PRODUCTS ONLY)

RT SHILDON RAIL TRAI	
QUANTITY	PRODUCT TYPE
5	PNQ Panel Square
1	TOT Totem
6	TOTAL (WFS PRODUCTS ONLY)

**NOTES:**  
Main Hall has been split out as its own zone to distinguish signage here from the urban realm. VNW and BJL located at Main Hall are new items that were not part of the original tender and would require costing.

# Schedule Locomotion

The sign schedule describes the intended content and construction for each sign referenced in the sign location plans. The *Notes* column captures any additional information relevant to that specific sign.

**Note :** the content shown is indicative only, and product type of some signs may change as the sites evolve.

### LOCOMOTION

### NH New Hall (including building identification)

SIGN REF	SIGN CATEGORY	SIGN PRODUCT TYPE	DIMENSIONS W x H x D (MM)	SIGN REQUIREMENTS			SIGN MESSAGE CONTENT	SIGN LOCATION				NOTES							
				FIXING	POWER	LIGHT		SPECIFICATIONS	FACE	ARROW	PICTO		PICTO TYPE	CONTENT	PROXIMITY	MAP	SITE	ZONE	LEVEL
<b>NH 0 NEW HALL Level 0</b>																			
LCM.NH.0.DON.DNA.FM.001	DON Donor Rec	DNA Vision 2025 Board	2050 x 1670 x 100	FM Fix mount	N No	N No	Can'tilevered cut powdercoated aluminum lettering mounted on top of panel. ±80 names waterjet/laser cut with contrast fill OR Acid etched on panel front. Panel constructed of bonded copper sheet front to powdercoated aluminum backing, with C-channel frame, to be mounted on to flat and curved all surface with coach bolt/domed nut fixings. Matt lacquer to seal colour and finish.	SOUTH	---	---	---	<Vision 2025>			LCM	NH New Hall	0 Ground	Vision 2025 by entrance	Copper alloy (Rimex Rosy Gold in Vortex/Granax finish) or similar may be acceptable alternative to natural copper. Any alloy must allow for etching or engraving of names. Any light/power provision to be given by architect
LCM.NH.0.DON.DNX.FM.001	DON Donor Rec	DNX Supporter Panel	400 x 1200 x 5	FM Fix mount	N No	N No	Printed self-adhesive vinyl backing to clear acrylic panel, with copper top and bottom frame and domed bolt fixings. Antiglare, Antiscratch and UV resistant	SOUTH	---	---	---	<Project Supporter>			LCM	NH New Hall	0 Ground	Project supporter recognition	
LCM.NH.0.DIR.PNQ.FH.001	DIR Direction	PNQ Panel Square	580 x 580 x 80	FH Fix hung	N No	N No	Powdercoated folded aluminium panel and fixings suspended from existing beam/ceiling. Printed graphics on panels, and stencilled lettering and graphics on beam posts. Panel suspended by welded galvanised rods from existing beam post (external) OR by wire with ceiling anchor/stop (internal). Antiglare, Anti-scratch, UV-/water-resistant.	WEST	↑	---	---	EXIT			LCM	NH New Hall	0 Ground	Suspended in hall aisle	Panel baseline to be 2.4-2.5m above F/L. If CCTV is nearby, mount to beam behind
LCM.NH.0.DIR.PNQ.FH.002	DIR Direction	PNQ Panel Square	580 x 580 x 80	FH Fix hung	N No	N No	Powdercoated folded aluminium panel and fixings suspended from existing beam/ceiling. Printed graphics on panels, and stencilled lettering and graphics on beam posts. Panel suspended by welded galvanised rods from existing beam post (external) OR by wire with ceiling anchor/stop (internal). Antiglare, Anti-scratch, UV-/water-resistant.	WEST	↑	---	---	EXIT			LCM	NH New Hall	0 Ground	Suspended in hall aisle	Panel baseline to be 2.4-2.5m above F/L. If CCTV is nearby, mount to beam behind
LCM.NH.0.DIR.PNQ.FH.003	DIR Direction	PNQ Panel Square	580 x 580 x 80	FH Fix hung	N No	N No	Powdercoated folded aluminium panel and fixings suspended from existing beam/ceiling. Printed graphics on panels, and stencilled lettering and graphics on beam posts. Panel suspended by welded galvanised rods from existing beam post (external) OR by wire with ceiling anchor/stop (internal). Antiglare, Anti-scratch, UV-/water-resistant.	WEST	↑	---	---	EXIT			LCM	NH New Hall	0 Ground	Suspended in hall aisle	Panel baseline to be 2.4-2.5m above F/L. If CCTV is nearby, mount to beam behind
LCM.NH.0.DIR.PNQ.FH.004	DIR Direction	PNQ Panel Square	580 x 580 x 80	FH Fix hung	N No	N No	Powdercoated folded aluminium panel and fixings suspended from existing beam/ceiling. Printed graphics on panels, and stencilled lettering and graphics on beam posts. Panel suspended by welded galvanised rods from existing beam post (external) OR by wire with ceiling anchor/stop (internal). Antiglare, Anti-scratch, UV-/water-resistant.	WEST	↑	---	---	EXIT			LCM	NH New Hall	0 Ground	Suspended in hall aisle	Panel baseline to be 2.4-2.5m above F/L. If CCTV is nearby, mount to beam behind
LCM.NH.0.DIR.PNM.FM.001	DIR Direction	PNM Panel Midi	320 x 240 x 5/80	FM Fix mount	N No	N No	Printed powdercoated aluminium OR steel dibond panel with black core/sealed edges. Colour-matched coach bolt fixings to suit mounting wall surface. Antiglare, Anti-scratch, UV-/water-resistant.								LCM	NH New Hall	0 Ground	Fixed to wall	
LCM.NH.0.IDN.PNP.AP.001	IDN ID Name	PNP Panel Petite	120 x 120 x 5	AP Applied	N No	N No	Powdercoated aluminium panel, printed graphics, 3M adhesive backing to suit surface								LCM	NH New Hall	0 Ground	Pictogram panel applied to door	
LCM.NH.0.IDN.PNJ.PJ.001	IDN ID Name	PNJ Panel Projecting	180/300/420 x 180 x 80	PJ Projecting	N No	N No	Folded powdercoat aluminium panel, printed graphics, coach bolt fixings to wall.	NORTH	---	---	---	Toilets and Baby Change			LCM	NH New Hall	0 Ground	Fixed perpendicularly to wall	
LCM.NH.0.INF.PNL.FM.001	INF Information	PNL Panel Large	510 x 510 x 5	FM Fix mount	N No	Y External	Printed powdercoated aluminium OR steel dibond panel with black core/sealed edges. Hidden fixings colour matched to panel, and method to suit mounting surface (wall/post). Raised lettering for opening times. Antiglare, Anti-scratch, UV-/water-resistant.	WEST	---	---	---	<Sister Museums>			LCM	NH New Hall	0 Ground	Mounted to wall by exit	
LCM.NH.0.INF.PNL.FM.002	INF Information	PNL Panel Large	510 x 510 x 5	FM Fix mount	N No	Y External	Printed powdercoated aluminium OR steel dibond panel with black core/sealed edges. Hidden fixings colour matched to panel, and method to suit mounting surface (wall/post). Raised lettering for opening times. Antiglare, Anti-scratch, UV-/water-resistant.	SOUTH	---	---	---	<Sister Museums>			LCM	NH New Hall	0 Ground	Mounted to wall by exit	
LCM.NH.0.INF.VNM.AP.001	INF Information	VNM Vinyl Midi	615/900 x 200/700 x 1	AP Applied	N No	N No	Self-adhesive opaque cut vinyl (3M) . Applied on reverse of glazing (glue on front).	SOUTH	---	---	---	<Welcome Info> No smoking including e-cigarettes Children must be supervised at all times Please do not litter Assistance dogs only CCTV in operation			LCM	NH New Hall	0 Ground	Applied to reverse of glass door	
LCM.NH.0.INF.VNM.AP.002	INF Information	VNM Vinyl Midi	615/900 x 200/700 x 1	AP Applied	N No	N No	Self-adhesive opaque cut vinyl (3M) . Applied on reverse of glazing (glue on front).	NORTH	---	---	---	<Welcome Info> No smoking including e-cigarettes Children must be supervised at all times Please do not litter Assistance dogs only CCTV in operation			LCM	NH New Hall	0 Ground	Applied to reverse of glass door	
<b>NH X NEW HALL External</b>																			
LCM.NH.X.IDA.STX.AP.001	IDA ID Arrival	STX Stencil Graphics X Big	±7100 x 900	AP Applied	N No	Y Uplight	Cut lettering (Painted/Powdercoated Aluminum/SAV Vinyl) to suit surface substrate	EAST	---	---	---	LOCOMOTION			LCM	NH New Hall	X External	Applied to New Hall facade facing parking	Orientation TBD. Colour dependent on cladding background Signal white is on obsidian cladding, Graphite Black is on cream cladding
LCM.NH.X.IDA.STX.AP.002	IDA ID Arrival	STX Stencil Graphics X Big	±7100 x 900	AP Applied	N No	Y Uplight	Cut lettering (Painted/Powdercoated Aluminum/SAV Vinyl) to suit surface substrate	WEST	---	---	---	LOCOMOTION			LCM	NH New Hall	X External	Applied to New Hall facade facing Dale Road	Colour dependent on cladding background Signal white is on obsidian cladding, Graphite Black is on cream cladding
LCM.NH.X.IDA.STH.AP.001	IDA ID Arrival	STH Stencil Graphics Huge	±2000 x 245	AP Applied	N No	Y Uplight	Painted stencil lettering (paint to suit surface substrate)	EAST	---	---	---	NEW HALL			LCM	NH New Hall	X External	Applied by visitor entrance Vertical alignment	Colour dependent on cladding background Signal white is on obsidian cladding, Graphite Black is on cream cladding
LCM.NH.X.IDA.STH.AP.002	IDA ID Arrival	STH Stencil Graphics Huge	±2000 x 245	AP Applied	N No	Y Uplight	Painted stencil lettering (paint to suit surface substrate)	NORTH	---	---	---	NEW HALL			LCM	NH New Hall	X External	Applied by visitor entrance Vertical alignment	Colour dependent on cladding background Signal white is on obsidian cladding, Graphite Black is on cream cladding
LCM.NH.X.INF.STE.AP.001	INF Information	STE Stencil Gr. Entrance	±1395/±2150 x 525	AP Applied	N No	Y External	Painted stencil lettering (paint to suit surface) OR cut vinyl to back of glazing	EAST	---	---	---	Welcome to Locomotion			LCM	NH New Hall	X External	Applied above visitor entrance	Colour dependent on cladding background Signal white is on obsidian cladding, Graphite Black is on cream cladding
LCM.NH.X.INF.STE.AP.002	INF Information	STE Stencil Gr. Entrance	±1395/±2150 x 525	AP Applied	N No	Y External	Painted stencil lettering (paint to suit surface) OR cut vinyl to back of glazing	NORTH	---	---	---	Welcome to Locomotion			LCM	NH New Hall	X External	Applied above visitor entrance	Colour dependent on cladding background Signal white is on obsidian cladding, Graphite Black is on cream cladding

### LOCOMOTION

### MH Main Hall facade and RT Shildon Rail Trail (inc. Historic Shildon Buildings)

SIGN REF	SIGN CATEGORY	SIGN PRODUCT TYPE	DIMENSIONS W x H x D (MM)	SIGN REQUIREMENTS			SIGN MESSAGE CONTENT						SIGN LOCATION				NOTES			
				FIXING	POWER	LIGHT	SPECIFICATIONS	FACE	ARROW	PICTO	PICTO TYPE	CONTENT	PROXIMITY	MAP	SITE	ZONE		LEVEL	LOCATION	
<b>MH X / 0 MAIN HALL External and Internal</b>																				
LCM.MH.X.IDN.BJL.AP.001	IDN ID Name	BJL Barrier Jacket	5500 x 700	AP Applied	N No	Y Uplight	PVC Tightly woven mesh 330gsm with concealed eyelet fixing along bottom, Or Painted board with brace fixing	EAST WEST	→ ←	— —	— —	— —	LOCOMOTION LOCOMOTION	— —	— —	LCM	UR Urban Realm	X External	Replaces existing barrier jacket	*New item type*
LCM.MH.X.IDA.STG.AP.003	IDA ID Arrival	STG Stencil Graphics Giant	5500 x 700	AP Applied	N No	Y Uplight	Painted stencil lettering (external paint to suit surface) OR cut vinyl applied to glazing	NORTH	→	—	—	—	LOCOMOTION	—	—	LCM	MH Main Hall	X External	Applied to Main Hall facade facing railway lines	
LCM.MH.X.IDA.STH.AP.006	IDA ID Arrival	STH Stencil Graphics Huge	±1200 x 175	AP Applied	N No	Y Uplight	Painted stencil lettering (paint to suit surface substrate)	WEST	←	—	—	—	MAIN HALL	—	—	LCM	MH Main Hall	X External	Applied to Main Hall facade to replace existing building ID	
LCM.MH.X.MAP.VNW.AP.001	MAP Map	VNW Vinyl Welcome	1970 x 940 x 1	AP Applied	N No	N No	Self-adhesive opaque cut vinyl (3M) . Applied on reverse of glazing.	WEST	←	—	—	—	<Welcome Info> No smoking including e-cigarettes Supervise children Children must be supervised at all times Please do not litter Assistance dogs only CCTV in operation	—	PRT <LCM-SW>	LCM	MH Main Hall	X External	Applied to glazing facing railway lines	*New item
LCM.MH.O.MAP.VNW.AP.002	MAP Map	VNW Vinyl Welcome	1970 x 940 x 1	AP Applied	N No	N No	Self-adhesive opaque cut vinyl (3M) . Applied on reverse of glazing.	EAST	→	—	—	—	<Welcome Info> No smoking including e-cigarettes Supervise children Children must be supervised at all times Please do not litter Assistance dogs only CCTV in operation	—	PRT <LCM-SW>	LCM	MH Main Hall	0 Ground	Applied to glazing facing cafe	*New item
<b>RT X SHILDON RAIL TRAIL External (Inc. Historic Shildon)</b>																				
LCM.RT.X.DIR.PNQ.FH.006	DIR Direction	PNQ Panel Square	580 x 580 x 80	FH Fix hung	Y Yes	Y External	Powdercoated folded aluminium panel and fixings suspended from existing beam/ceiling. Printed graphics on panels, and stencilled lettering and graphics on beam posts. Panel suspended by welded galvanised rods from existing beam post (external) OR by wire with ceiling anchor/stop (internal). Antiglare, Anti-scratch, UV-water-resistant.	EAST WEST	↑ ↓	— —	— —	— —	HISTORIC SHILDON Shildon Station LOCOMOTION Shildon Station	500m 25m 200m 25m	— —	LCM	RT Rail Trail	X External	Suspended from gallow beam Along path by station crossing	illumination to be provided by pathway lighting, gallow beam is existing
LCM.RT.X.DIR.PNQ.FH.007	DIR Direction	PNQ Panel Square	580 x 580 x 80	FH Fix hung	Y Yes	Y External	Powdercoated folded aluminium panel and fixings suspended from existing beam/ceiling. Printed graphics on panels, and stencilled lettering and graphics on beam posts. Panel suspended by welded galvanised rods from existing beam post (external) OR by wire with ceiling anchor/stop (internal). Antiglare, Anti-scratch, UV-water-resistant.	NORTH SOUTH	← →	— —	— —	— —	LOCOMOTION HISTORIC SHILDON Shildon Station HISTORIC SHILDON LOCOMOTION	200m 500m 25m 500m 200m	— —	LCM	RT Rail Trail	X External	Suspended from gallow beam Along path by station crossing	illumination to be provided by pathway lighting, gallow beam is existing
LCM.RT.X.DIR.PNQ.FH.008	DIR Direction	PNQ Panel Square	580 x 580 x 80	FH Fix hung	Y Yes	Y External	Powdercoated folded aluminium panel and fixings suspended from existing beam/ceiling. Printed graphics on panels, and stencilled lettering and graphics on beam posts. Panel suspended by welded galvanised rods from existing beam post (external) OR by wire with ceiling anchor/stop (internal). Antiglare, Anti-scratch, UV-water-resistant.	EAST WEST	↑ ↓	— —	— —	— —	HISTORIC SHILDON Shildon Station LOCOMOTION	100m 200m 500m	— —	LCM	RT Rail Trail	X External	Suspended from gallow beam Along path by stables	illumination to be provided by pathway lighting, gallow beam is existing
LCM.RT.X.DIR.PNQ.FH.009	DIR Direction	PNQ Panel Square	580 x 580 x 80	FH Fix hung	Y Yes	Y External	Powdercoated folded aluminium panel and fixings suspended from existing beam/ceiling. Printed graphics on panels, and stencilled lettering and graphics on beam posts. Panel suspended by welded galvanised rods from existing beam post (external) OR by wire with ceiling anchor/stop (internal). Antiglare, Anti-scratch, UV-water-resistant.	EAST WEST	↑ ↓	— —	— —	— —	HISTORIC SHILDON Shildon Station LOCOMOTION	100m 200m 500m	— —	LCM	RT Rail Trail	X External	Suspended from gallow beam at Historic Shildon	illumination to be provided by pathway lighting, gallow beam is existing
LCM.RT.X.IDA.PNQ.FH.002	IDA ID Arrival	PNQ Panel Square	580 x 580 x 80	FH Fix hung	Y Yes	Y External	Powdercoated folded aluminium panel and fixings suspended from existing beam/ceiling. Printed graphics on panels, and stencilled lettering and graphics on beam posts. Panel suspended by welded galvanised rods from existing beam post (external) OR by wire with ceiling anchor/stop (internal). Antiglare, Anti-scratch, UV-water-resistant.	EAST WEST	— —	— —	— —	— —	HISTORIC SHILDON HISTORIC SHILDON	— —	— —	LCM	RT Rail Trail	X External	Suspended from gallow beam at Historic Shildon	illumination to be provided by pathway lighting, gallow beam is existing
LCM.RT.X.INF.TOT.FS.003	INF Information	TOT Totem	510 x 2000 x 150	FS Freestand	N No	Y External	5mm anodised aluminium panels mounted to C-channel steel framework. Powdercoated frame, panels and fixings (clinch stud/dome nut). Graphics printed onto panel front and stencilled lettering on C-channel sides. Antiglare, Anti-scratch, UV-water-resistant.	EAST WEST	— —	— —	— —	— —	<Welcome Info> <Opening times> <Welcome Info> <Opening times> LOCOMOTION Shildon Station	— —	PRT <LCM-HS> PRT <LCM-HS>	LCM	RT Rail Trail	X External	Placed at Historic Shildon at start of path	illumination provided by existing lighting

### LOCOMOTION

### UR Urban realm (including car parks)

SIGN REF	SIGN CATEGORY	SIGN PRODUCT TYPE	DIMENSIONS W x H x D (MM)	SIGN REQUIREMENTS			SIGN MESSAGE CONTENT				SIGN LOCATION				NOTES				
				FIXING	POWER	LIGHT	SPECIFICATIONS	FACE	ARROW	PICTO	PICTO TYPE	CONTENT	PROXIMITY	MAP		SITE	ZONE	LEVEL	LOCATION
UR X URBAN REALM External (inc. car parks)																			
LCM.UR.X.IDA.STX.AP.001	IDA ID Arrival	STX Stencil Graphics X Big	5500 x 700	AP Applied	N No	Y Uplight	Cut lettering (Painted/Powdercoated Aluminum/SAV Vinyl) to suit surface substrate	WEST				LOCOMOTION			LCM	UR Urban Realm	X External	Applied to Spout Bridge Permissions pending	Product subject to change, pending permissions Lettering on masonry bridge, ideally painted/powdercoated aluminum
LCM.UR.X.IDN.PNQ.FH.001	IDN ID Name	PNQ Panel Square	580 x 580 x 80	FH Fix hung	Y Yes	Y External	Powdercoated folded aluminium panel and fixings suspended from existing beam/ceiling. Printed graphics on panels, and stencilled lettering and graphics on beam posts. Panel suspended by welded galvanised rods from existing beam post (external) OR by wire with ceiling anchor/stop (internal). Antiglare, Anti-scratch, UV-water-resistant.	NORTH		■	Engine Platform	ENGINE RAILWAY			LCM	EP Engine Platform	X External	Suspended from gallow beam By Engine Railway platform	Illumination to be provided by pathway lighting, gallow beam is existing
LCM.UR.X.IDN.PNQ.FH.002	IDN ID Name	PNQ Panel Square	580 x 580 x 80	FH Fix hung	N No	N No	Powdercoated aluminium panel and edges, stencilled graphics, suspended from existing posts. Antiglare, UV resistant, Anti-scratch.	EAST				Picnic Area			LCM	UR Urban Realm	X External	Suspended from gallow beam	
LCM.UR.X.INF.PNL.FM.002	INF Information	PNL Panel Large	510 x 510 x 5	FM Fix mount	N No	Y External	Printed powdercoated aluminium OR steel dibond panel with black core/sealed edges. Hidden fixings colour matched to panel, and method to suit mounting surface (wall/post). Raised lettering for opening times. Antiglare, Anti-scratch, UV-water-resistant.	WEST				Picnic Area Play Area			LCM	UR Urban Realm	X External	Fixed to pedestrian gate wall	
LCM.UR.X.INF.PNG.FM.001	INF Information	PNG Panel Gate	±1700 x 1700 x 5	FM Fix mount	N No	Y External	Anodised powdercoated aluminium OR Steel dibond panel with black core/ sealed edges. Printed graphics and raised lettering for opening times. Hidden tamper-proof fixings to suit existing gate. Antiglare, Anti-scratch, UV-water-resistant	SOUTH				<Welcome Info>			LCM	UR Urban Realm	X External	Fixed to underpass gate	
LCM.UR.X.INF.RDL.FX.001	INF Information	RDL Road Sign Large	1020 x 1020 x 5	XX Other	N No	Y External	Steel dibond printed panel with black core and sealed edges, mounted to posts. Antiglare, Anti-scratch, UV-water-resistant.	WEST				<Welcome Info>			LCM	UR Urban Realm	X External	Fixed to underpass gate By Spout Bridge	
LCM.UR.X.INF.RDL.FX.003	INF Information	RDL Road Sign Large	1020 x 1020 x 5	XX Other	N No	Y External	Steel dibond printed panel with black core and sealed edges, mounted to posts. Antiglare, Anti-scratch, UV-water-resistant.	SOUTH	■	■	Car Park Accessible Blue Badge	Car park Accessible Parking (for Blue Badge Holders)			LCM	UR Urban Realm	X External	Pole/Gate mounted by car park	Ideally, illumination to be provided by existing lighting
LCM.UR.X.INF.RDL.FX.004	INF Information	RDL Road Sign Large	1020 x 1020 x 5	XX Other	N No	Y External	Steel dibond printed panel with black core and sealed edges, mounted to posts. Antiglare, Anti-scratch, UV-water-resistant.	SOUTH	■	■	Accessible Blue Badge	Accessible Parking (for Blue Badge Holders)			LCM	UR Urban Realm	X External	Pole/Gate mounted by car park	Ideally, illumination to be provided by existing lighting Position may change, dependent final parking layouts and flows
LCM.UR.X.INF.RDL.FX.005	INF Information	RDL Road Sign Large	1020 x 1020 x 5	XX Other	N No	Y External	Steel dibond printed panel with black core and sealed edges, mounted to posts. Antiglare, Anti-scratch, UV-water-resistant.	SOUTH	↑	■	Accessible Blue Badge	Accessible Parking (for Blue Badge Holders)			LCM	UR Urban Realm	X External	Pole/Gate mounted by car park	Ideally, illumination to be provided by existing lighting Position may change, dependent final parking layouts and flows
LCM.UR.X.MAP.BES.FS.001	MAP Map	BES Tactile lec. map	1500 x 800 x 1130	FS Freestand	N No	N No	Mixed material map (3D print or similar) w/ lasercut/extruded graphics + blocks. Durable bonds required for extruded elements to withstand frequent use. Tilt-mounted on powdercoated lectern plinth with coach bolt/domed nut fixings. Antiglare, Anti-scratch, UV-water-resistant.	WEST				<Map>		TAC <LCM-LCM>	LCM	UR Urban Realm	X External	Within LCM Engine Yard	
LCM.UR.X.MAP.TOT.FS.001	MAP Map	TOT Totem	510 x 2000 x 150	FS Freestand	N No	Y External	5mm anodised aluminium panels mounted to C-channel steel framework. Powdercoated frame, panels and fixings (clinch stud/dome nut). Graphics printed onto panel front and stencilled lettering on C-channel sides. Antiglare, Anti-scratch, UV-water-resistant.	EAST	↑			EXIT	200m	PRT <LCM-SW>	LCM	UR Urban Realm	X External	At entry path by Spout Bridge	
LCM.UR.X.MAP.TOT.FS.002	DIR Direction	TOT Totem	510 x 2000 x 150	FS Freestand	N No	Y External	5mm anodised aluminium panels mounted to C-channel steel framework. Powdercoated frame, panels and fixings (clinch stud/dome nut). Graphics printed onto panel front and stencilled lettering on C-channel sides. Antiglare, Anti-scratch, UV-water-resistant.	EAST	↑	■	Train Station	(for SHILDON RAIL TRAIL and <Shildon Station>)	200m		LCM	UR Urban Realm	X External	Along path to New Hall	
LCM.UR.X.MAP.TOT.FS.003	MAP Map	TOT Totem	510 x 2000 x 150	FS Freestand	N No	Y External	5mm anodised aluminium panels mounted to C-channel steel framework. Powdercoated frame, panels and fixings (clinch stud/dome nut). Graphics printed onto panel front and stencilled lettering on C-channel sides. Antiglare, Anti-scratch, UV-water-resistant.	WEST	↑	■	Car Park	NEW HALL NEW HALL EXIT (for Car Park <Accessible Parking>)	100m 100m 200m		LCM	UR Urban Realm	X External	At entry path by parking	Position may change, dependent final parking layouts and flows
LCM.UR.X.MAP.TOT.FS.003	MAP Map	TOT Totem	510 x 2000 x 150	FS Freestand	N No	Y External	5mm anodised aluminium panels mounted to C-channel steel framework. Powdercoated frame, panels and fixings (clinch stud/dome nut). Graphics printed onto panel front and stencilled lettering on C-channel sides. Antiglare, Anti-scratch, UV-water-resistant.	EAST	↑			Car park	150m	PRT <LCM-SW>	LCM	UR Urban Realm	X External	At entry path by parking	Position may change, dependent final parking layouts and flows
LCM.UR.X.MAP.TOT.FS.003	MAP Map	TOT Totem	510 x 2000 x 150	FS Freestand	N No	Y External	5mm anodised aluminium panels mounted to C-channel steel framework. Powdercoated frame, panels and fixings (clinch stud/dome nut). Graphics printed onto panel front and stencilled lettering on C-channel sides. Antiglare, Anti-scratch, UV-water-resistant.	WEST	↑	■	Car Park	NEW HALL MAIN HALL ENGINE RAILWAY <Thanks for visiting> Car park EXIT	100m 150m 200m 150m 25m		LCM	UR Urban Realm	X External	At entry path by parking	Position may change, dependent final parking layouts and flows
LCM.UR.X.STT.PNS.FM.006	STT Statutory	PNS Panel Small	240 x 240 x 5	FM Fix mount	N No	N No	Printed powdercoated aluminium panel with raised lettering for level directorie Colour matched coach bolt fixings, or to suit mounting surface (wall/post/glazing) Raised lettering for opening times. Antiglare, Anti-scratch, UV-water-resistant	EAST		■	Shut gates	Please close the gate behind you			LCM	UR Urban Realm	X External	Mounted to fence gate	
LCM.UR.X.STT.PNS.FM.007	STT Statutory	PNS Panel Small	240 x 240 x 5	FM Fix mount	N No	N No	Printed powdercoated aluminium panel with raised lettering for level directorie Colour matched coach bolt fixings, or to suit mounting surface (wall/post/glazing) Raised lettering for opening times. Antiglare, Anti-scratch, UV-water-resistant	NORTH		■	Supervise children	Children must be supervised at all times			LCM	UR Urban Realm	X External	Mounted to fence gate	
LCM.UR.X.STT.PNS.FM.007	STT Statutory	PNS Panel Small	240 x 240 x 5	FM Fix mount	N No	N No	Printed powdercoated aluminium panel with raised lettering for level directorie Colour matched coach bolt fixings, or to suit mounting surface (wall/post/glazing) Raised lettering for opening times. Antiglare, Anti-scratch, UV-water-resistant			■	No Smoking	No smoking including e-cigarettes			LCM	UR Urban Realm	X External	Mounted to fence gate	

## Wayfinding guidelines and toolkit

The following chapter provide an overview of wayfinding essentials, graphic assets and layout principles which form the basis of the wayfinding design for the National Railway Museum and Locomotion. For more information on specific wayfinding product types including the character limits, please refer to *Specifications Intent*.

Wayfinding adopts design assets from the Science Museum Group brand toolkit, and adapting assets only where necessary to ensure that wayfinding is coherent with the brand, yet effective and accessible as signage products across the museum sites.

The result is a wayfinding scheme that shares design values of the Science Museum Group, and that is easy and effective for visitors to become familiar with and follow as they explore the museum.

Essentials : wayfinding basics

The act of wayfinding doesn't take place in isolation. The surrounding environment and services are all part of the experience of navigating a space. Before focusing on the elements of wayfinding, it is necessary to highlight the essentials when planning a space to meet visitors' basic needs.

If done well, meeting visitors' basic needs should appear invisible and create solid ground for delivering those little extras which can elevate their experience.



OPEN FOR ALL  
ACCESSIBLE, INCLUSIVE

CONNECTED  
RELIABLE WIFI ENABLED

BEAUTIFUL  
GIVES A GOOD IMPRESSION  
WELL MADE

WELCOMING  
PLEASE USE, COME IN

DWELL  
SPEND TIME, ENJOY

SAFE  
SECURE, WELL LIT

CLEAN  
HYGIENIC, TIDY,  
LOOKED AFTER

COMFORTABLE  
RELAX, COME AGAIN

Background visual by OPEN



### Essentials : wayfinding best practices

Wayfinding can improve how visitors interact with and engage with the character of a place, by quickly and effectively aiding decision-making through identification, orientation and direction, and encouraging exploration.

#### The best wayfinding practices:

##### Create recognition and identification

If its easy to spot in its environment, its easy to follow, attracting attention from afar

##### Use consistency and predictability

Standardising how and where information is placed and set –building confidence in visitors to find what they need and act upon it more easily

##### Provide answers at the right time

Through progressive disclosure, just the right amount of information is given, just when it is needed to aid decision making.

##### Establish information hierarchy

Simplifying and grouping information into learnable chunks according to importance, and separating different types of content improves cognition

##### Reduce visual noise

Too much information is unhelpful. Reducing visual clutter improves prominence and clarity

##### Adopt logical naming

Consistent, unique and simple naming structures, are easier to remember, understand and navigate. Calling the same thing by different names, or using the same words for different places may cause confusion.

##### Encourage exploration

Creating a visual map of the area/site aids orientation and encourages exploration

##### Create inclusivity and belonging

Different people have different needs, different knowledge of an area and different journey times, different abilities. By responding to these needs wayfinding is considerate of everybody.



**Essentials : naming best practices**

Naming conventions are a key element to wayfinding, and should be consistent at every touchpoint that forms part of the visitor journey to avoid confusion.

**Pre-visit** : online, emails, and marketing

**On site** : on signs, buildings, maps, marketing

**Word of mouth** : staff and locals should give be able to give directions using the same names and descriptions.

Considerations should also ensure that names are:

**Short** : and simple to read, legible on the go (2-3 words)

**Logical** : to understand and consistent across all sites

**Unique** : and memorable to recognise (avoids duplication)

**Easy** : to say and spell by everyone

**Inclusive** : of all to be welcoming and usable

**Relate-able** : to the area and describable

When naming is long, difficult to remember, confusing, they are likely to be renamed or shortened by staff to make it easier to give directions, create meeting points or remember –which may confuse visitors.

**Note** : to find out more about character or word limits on specific sign product types, please refer to *Specifications Intent*.

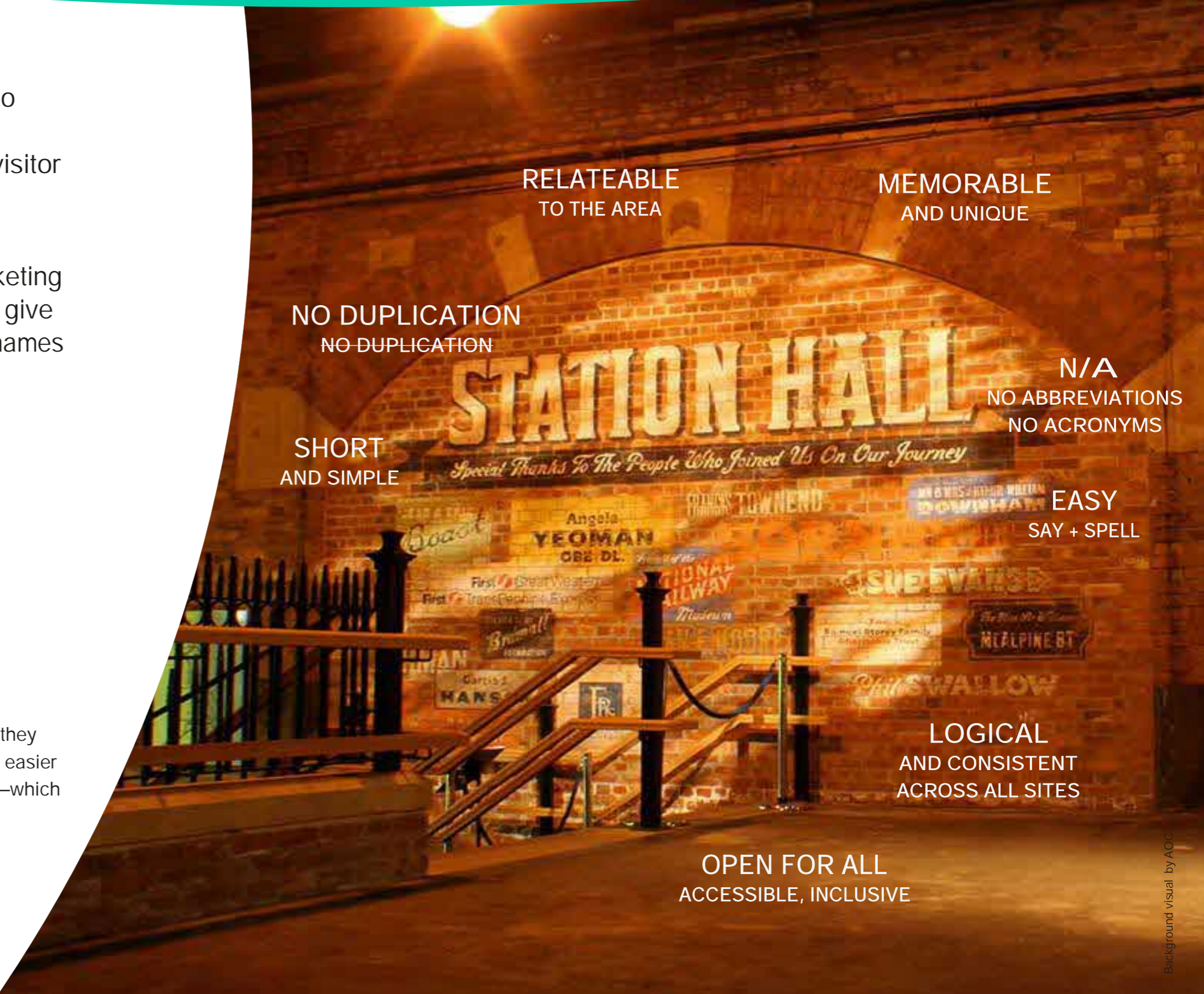

RELATEABLE  
TO THE AREA

MEMORABLE  
AND UNIQUE

NO DUPLICATION  
NO DUPLICATION

N/A  
NO ABBREVIATIONS  
NO ACRONYMS

SHORT  
AND SIMPLE

EASY  
SAY + SPELL

LOGICAL  
AND CONSISTENT  
ACROSS ALL SITES

OPEN FOR ALL  
ACCESSIBLE, INCLUSIVE

**Palette : colour and materiality**

The palette for wayfinding is derived from the brand, architecture and engineering –with colours, materiality, and construction inspired by the estate and railways –the wayfinding palette is bold, contemporary and connected to the museum, its surroundings and railway engineering.

The monochromatic colour scheme offers is not only bold but accessible also –offering a tonal contrast that far exceeds the minimum 70% tonal contrast required for legibility. Colour accents also help to punctuate products from the environment and/or emphasis icons when necessary.

Finishes are deliberately matt or low sheen to avoid glare against content.

Where fixing methods are exposed, these should be colour matched to product fascias and tamper-proof.

For sign specific colour or materiality, please refer to the wayfinding schedule or *Specifications Intent*.

<p><b>GRAPHITE</b></p> <p>RAL 9011 89% contrast</p> <p>For backgrounds and map details</p>	<p><b>SIGNAL WHITE</b></p> <p>RAL 9003 7% contrast</p> <p>For content and map elements</p>
<p><b>CARMINE RED</b></p> <p>NCS S 2570-Y90R RAL 3002 91% contrast</p> <p>For accent details</p>	<div style="background-color: #000000; color: white; padding: 10px; vertical-align: top;"> <p><b>JET BLACK</b></p> <p>RAL 9005 93% contrast</p> <p>For details</p> </div> <div style="background-color: #f0f0f0; padding: 10px; vertical-align: top;"> <p><b>CREAM</b></p> <p>RAL 9001 11% contrast</p> <p>For details</p> </div>

**COLOUR PALETTE**

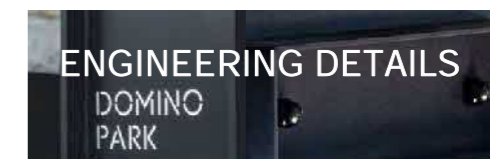

**MATERIALS**

Type : typeface

The wayfinding sign family adopts the SMG typeface.

Typeface usage is adapted the brand guidelines and optimised to suit the requirements for wayfinding in terms of scale or weight for reading range, application method limitations or other product/environmental constraints.

Please refer to *Specifications Intent* for examples of how type is used on each sign product type, as well as indications for typical character limits or typesetting.

Aa Bb Cc Dd Ee Ff  
Gg Hh Ii Jj Kk Ll Mm  
Nn Oo Pp Qq Rr Ss  
Tt Uu Vv Ww Xx Yy Zz  
1 ? ? ? ? ? ? ? ? 0

Note : visuals shown are taken from the SMG Brand Guidelines to for demonstrative purposes only

SMG TYPEFACE

Type : type sizes

Wayfinding content appears at standardised sizes across signage products, providing a consistent scale and treatment for wayfinding across the site.

Type sizes have been determined based on typical architecture or product scale across the site, and scaled to ensure signage can be read easily, whether from afar at speed or up-close in detail.

LOGGO

CAP 600-1800 mm | 200+m reading range  
Typically museum logo

ZONE IDENTIFIER

CAP 125-245 mm | 55-80 m reading range  
Typically zone/collection identifier

AREA / Facility / Vehicular

x-Height 45-90 mm | 20-40 m reading range  
Typically area name or vehicular content

Directional/Overview information

x-Height 15-30 mm | 7-14 m reading range  
Typically pedestrian directional information

Descriptive information

x-Height 7.5-9 mm | 3.5-4 m reading range  
Typically descriptive information

Statutory information

x-Height 3.75-5 mm | 1.5-2.5 m reading range  
Typically statutory information

SHOWN @ 9% ACTUAL SIZE

Type : type chart

This chart shows the lowercase x-height and the ideal reading distance range from which they are legible.

The size of typeface on sign products is determined by the distance and height any critical information on a sign is required to be read from.

Please refer to product specifications for type sizes on each product type.

Typical type size summary

3.75-5 mm	Typically statutory	1.5-2.5 m
7.5-9 mm	Typically info	3.5-4 m
15-30 mm	Typically directional/info	7-14 m
45-90 mm	Typically vehicular/identifier/threshold	20-40 m
125-175 mm	Typically area identifier	55-78 m
500+ mm	Typically museum identifier	200+ m

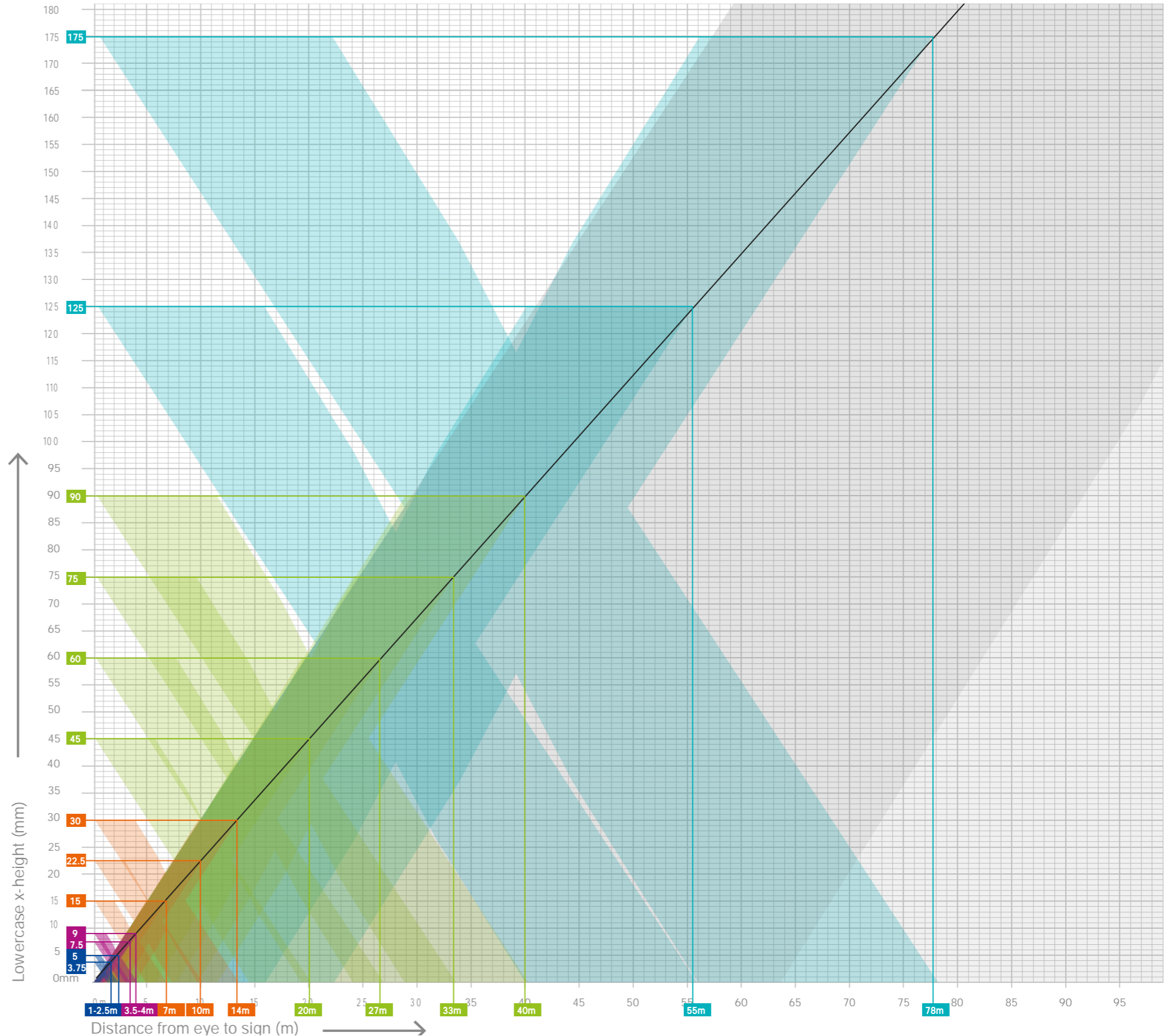

**Assets : identification (museum logos)**

Museums are identified with their respective logo.

Typically identification is shown in horizontal orientation, however, in special case vertical orientation is possible. Please refer to the sign schedule for more details at specific locations.

For more information about logos and their usages, please refer to the *SMG Brand Guidelines*.



**Note** : visuals shown are taken from the SMG Brand Guidelines to for demonstrative purposes only.

Information assets : pictograms

The wayfinding sign family adopts the SMG pictogram family suite for consistency with the brand.

When shown in a bounding box, pictograms typically appear in negative format, where the bounding box matches the colour of text, and icon matches the colour of the background.

Typically, pictograms are shown in a bounding box when used on directions or as identification, and appear without a bounding box when used as statutory or informative signage.

FACILITY / SERVICE PICTOGRAMS



INFORMATIVE / STATUTORY PICTOGRAMS



**Note** : please refer to *PICTOGRAM AUDIT* for a list of pictograms identified in the signage schedule and outstanding from the current existing pictogram suite shared.



**Assets : directional (arrows + proximity)**

Wayfinding adopts design assets from the Science Museum Group brand toolkit, and enhance aspects to meet the specific requirements of the museum sites.

Arrows indicate the direction of travel or a level change for a given destination, and are shown as twice the x-height of text.

Proximity indicated the distance to reach a destination in metres, and are shown at half the x-height of text. Proximity is useful to inform visitors of the distance to reach key facilities and/or attractions.

Both arrows and proximity are shown in the same colour as text on signage.

DIRECTIONAL ICONS

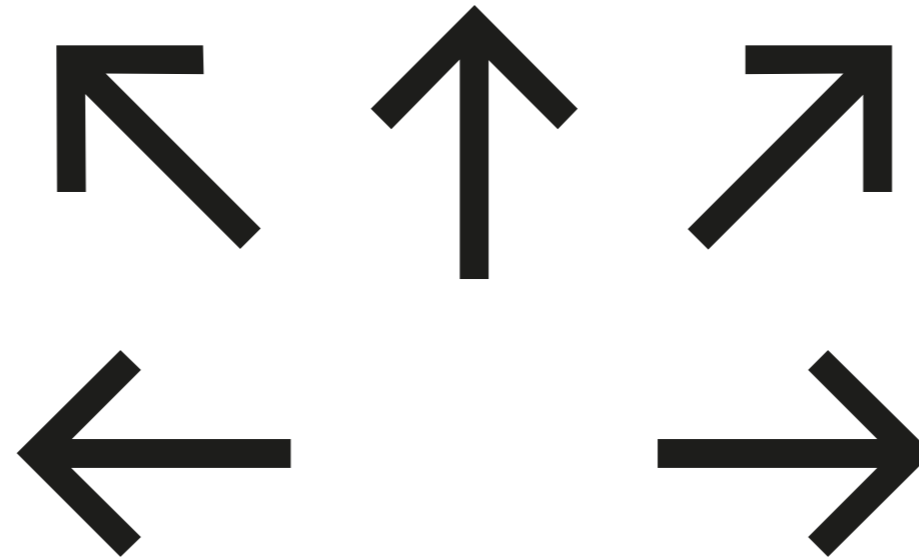

ACCESS ICONS

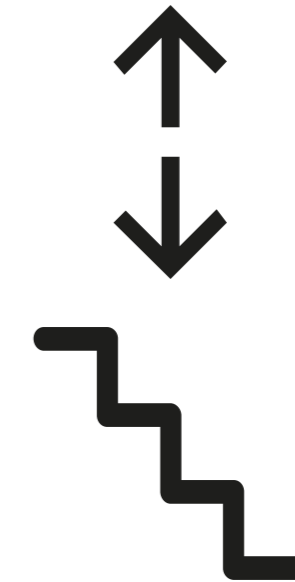

PROXIMITY



Assets : orientation (sitewide map)

The wayfinding sign family adopts SMG design assets and mapping style for consistency with the brand, but adapt the layout configuration and scale to suit its usage in situ at these particular museum sites, and are designed to be updateable.

Sitewide maps are typically found external in square format on totems and walls, and provide an overview of the museum within the site perimeter.

Maps use icons to identify where you are on the site, the museum building, access, attractions and facilities, and may indicate city transport hubs or landmarks beyond.

A legend and QR code enable further information to be found.

Typically monochromatic in tones of black and white, an accent colour is also available to emphasise location.

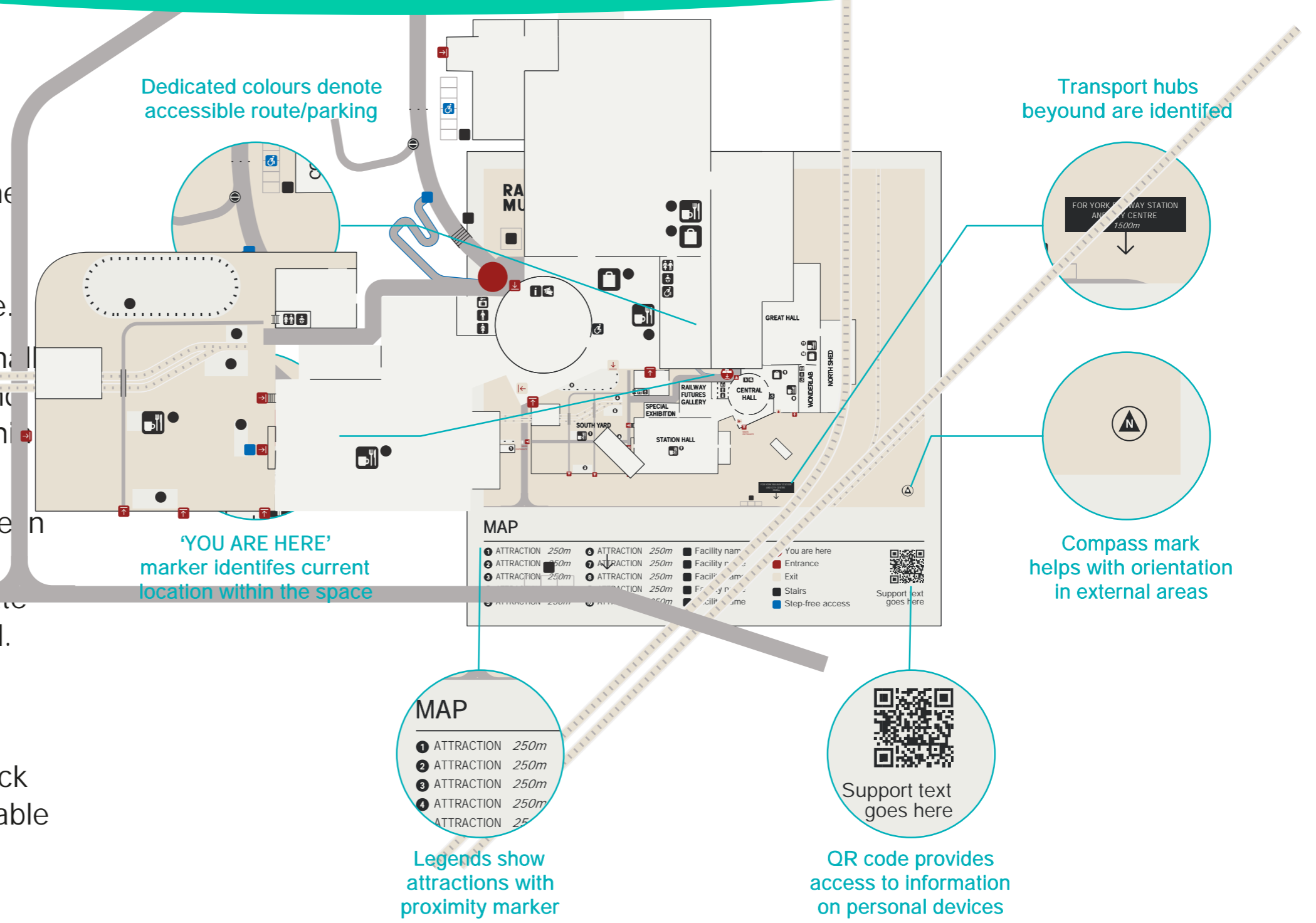

Note : visual is for demonstrative purposes only and not indicative of final design, maps will be designed in detail as part of artworking in the next stage. Please ensure all assets required for maps are supplied in print ready format ahead of artwork production.

Assets : orientation (area map)

The wayfinding sign family adopts SMG design assets and mapping style for consistency with the brand, but adapt the layout configuration and scale to suit its usage in situ at these particular museum sites, and are designed to be updateable.

Area maps are typically found indoors on walls in landscape format, and give an overview of the current area and summary of areas beyond.

Maps use icons to identify where you are in the site, the museum building, access, attractions and facilities.

A legend and QR code enable further information to be found. Photographs offer at a quick peek of attractions and/or special exhibitions in the area.

Typically monochromatic in tones of black and white, an accent colour is also available to emphasise location.

Note : visual is for demonstrative purposes only and not indicative of final design, maps will be designed in detail as part of artworking in the next stage. Please ensure all assets required for maps are supplied in print ready format ahead of artwork production.

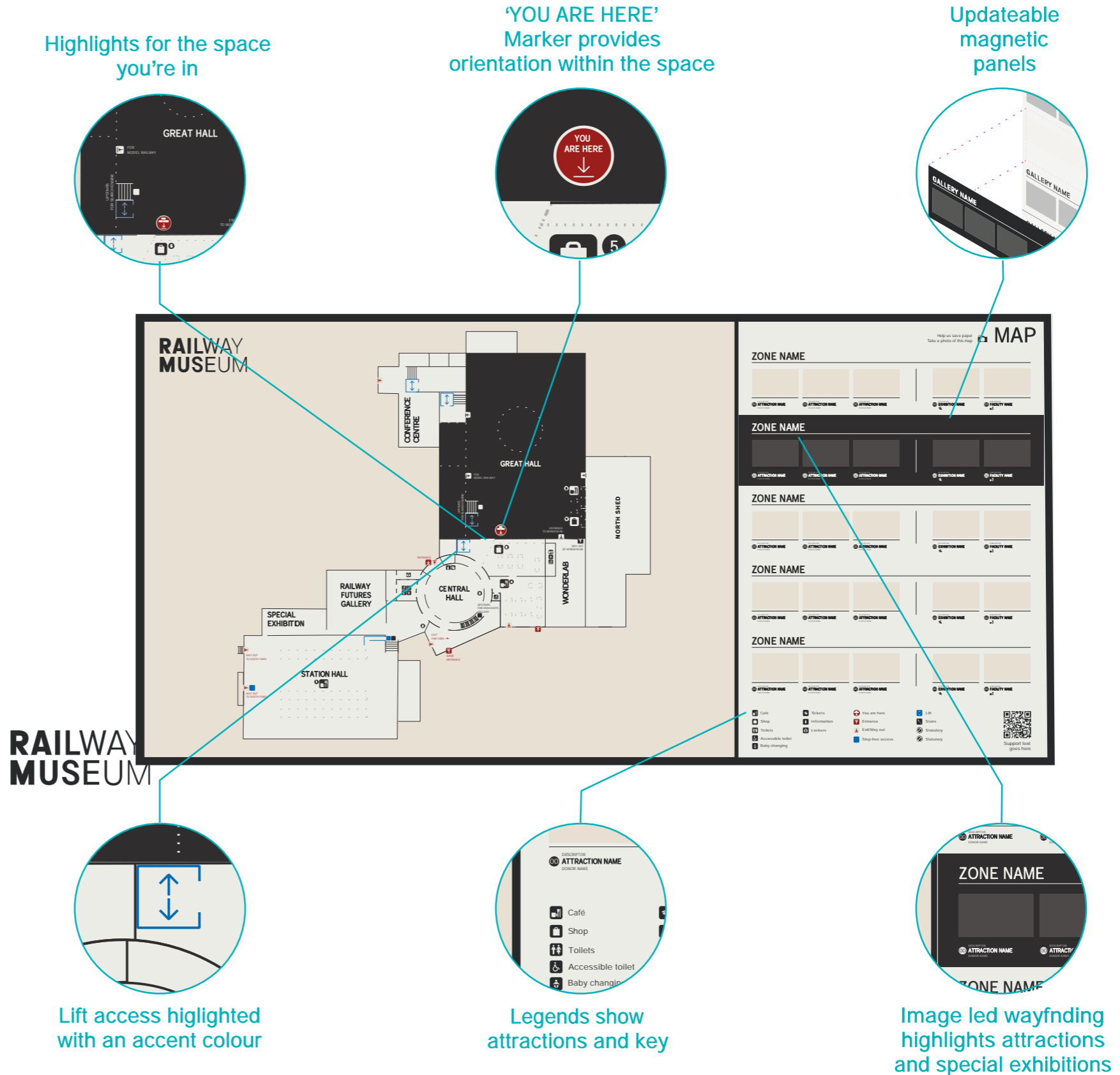

Assets : pictogram audit (required for signage)

Using the sign schedule, a list of pictograms has been identified that would be required for wayfinding.

It is the responsibility of the client to provide all pictograms identified here ahead of artwork production. Any pictograms outstanding from pictogram library must be designed by the SMG Design Team.

**PICTOGRAM TYPE REQUIRED FOR WFS**

North facing compass	1	No Flash Photography	1
Accessible	1	No Littering	1
Authorised staff only	1	No pedestrians	1
Baby change	1	No Smoking	1
Beware	1	Pedestrian Crossing	1
Bicycle Parking	1	Pedestrian Priority	1
Blue Badge	1	Picnic	1
Cafe	1	Playground	1
Car Park	1	Proximity accessible	1
CCTV	1	Proximity person	1
Changing Places	1	Ramp	1
Coach	1	School Groups	1
Dogs on Leash	1	Shop	1
EV Charging	1	Shut gates	1
Fire exit	1	Smart Devices	1
Garden	1	Staff	1
Guide Dogs	1	Staff pass	1
Hearing Loop T	1	Stairs	1
Information Point	1	Supervise children	1
Level Crossing	1	Taxi	1
Lift	1	Tickets	1
Lockers	1	Toilet Accessible	1
Meadow Garden	1	Toilet Unisex	1
Meeting point	1	Toilets	1
No cycling	1	Toilets Female	1
No Dogs Allowed	1	Toilets Male	1
No Entry	1	Train Station	1
No filming	1	Walking man	1
		<b>TOTAL</b>	<b>55</b>

Principles : placement

Consistency of sign placement enables visitors to always know where to look for information they need.

A fix suite of vertical datum has been set for wayfinding, for clarity and consistent to ensure visibility and accessibility.

- 0-0.6m : clear of printed wayfinding cannot fall within this range
- 0.65-1.6m : ideal for raised and/or tactile elements
- 1.1-1.8m : optimal range for detailed content such as maps or small directions
- 1.5-3.2m : optimal range for vehicular signage (with car park signage above 1.5m)
- 2.1-2.4m : ideal for projecting and overhead signs
- 2.4-3.2m : fixed height above floor level for fingerpost and entrance/threshold signs

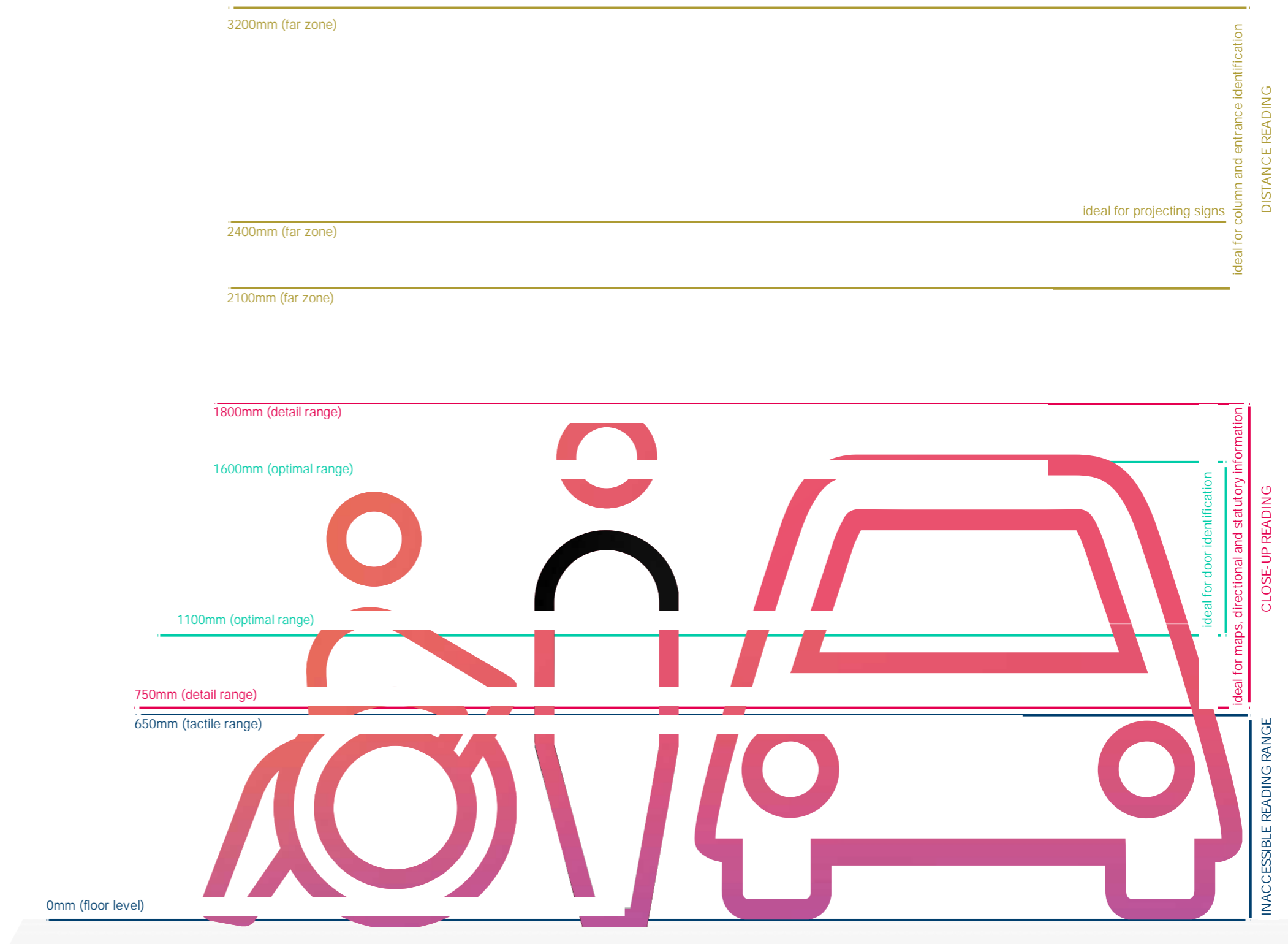

**Note** : datums shown are based on ergonomic and accessible best practices, some deviations may occur based on environmental constraints

Principles : categorising

Establishing a hierarchy for information on signage allows visitors to more easily find the information they seek.

- **LOCATION** : *Where am I?*  
Typically an area name identifier, found on the side, post or top of signs.
- **DIRECTION** : *Which way and how far?*  
Typically arrow led, pointing to the museum, attractions, key facilities or exits (with proximity on pedestrian signage)
- **ORIENTATION** : *What is around?*  
Typically a map providing locational information and placed beneath directions on signage
- **SUPPLEMENTARY** : *Anything else to note?*  
Typically legends, statutory or access to online information, placed at the bottom of signage

**Note** : whilst these principles are based on best practices, some deviations may occur product to product based on content requirements or signage constraints.

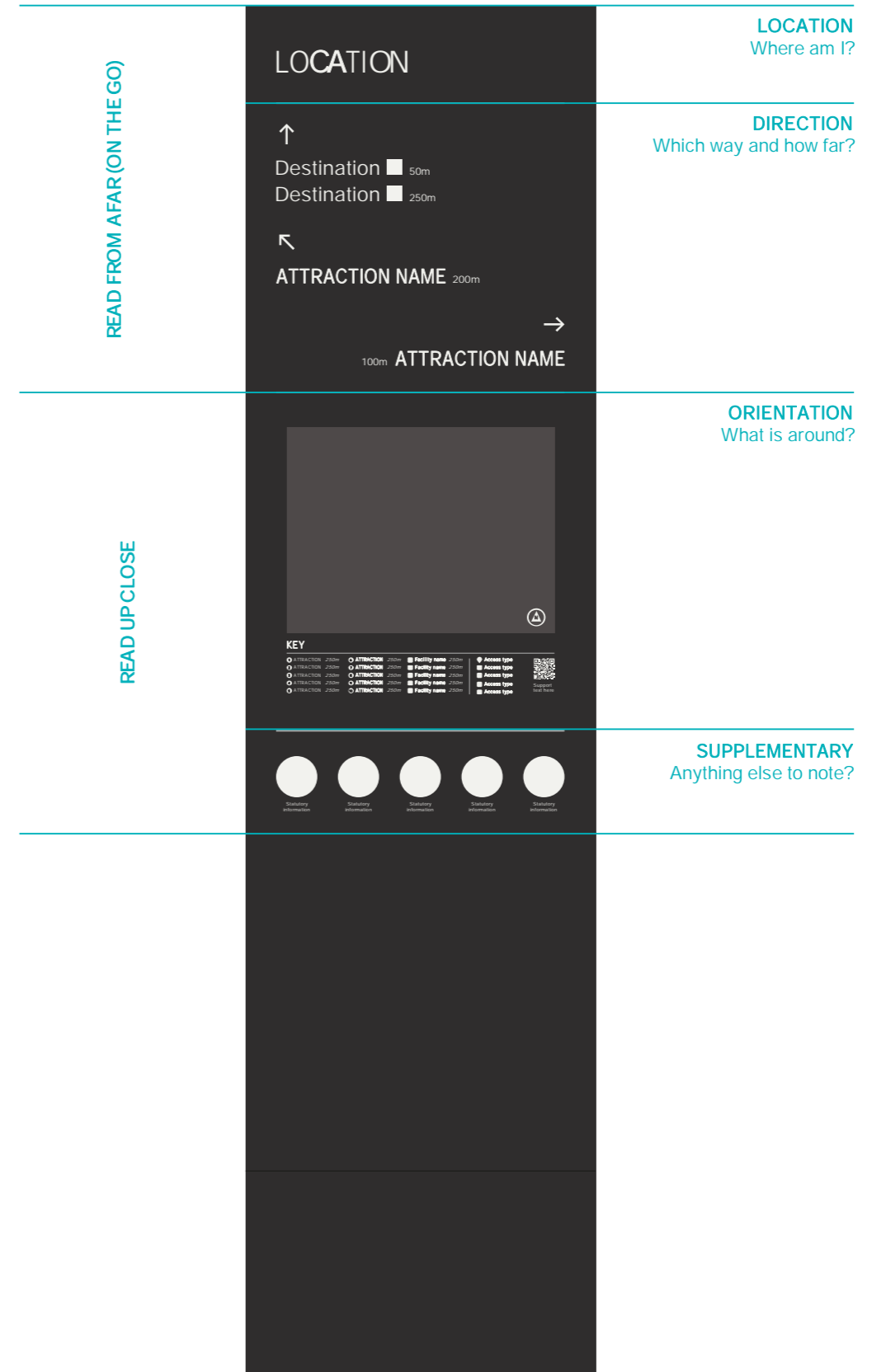
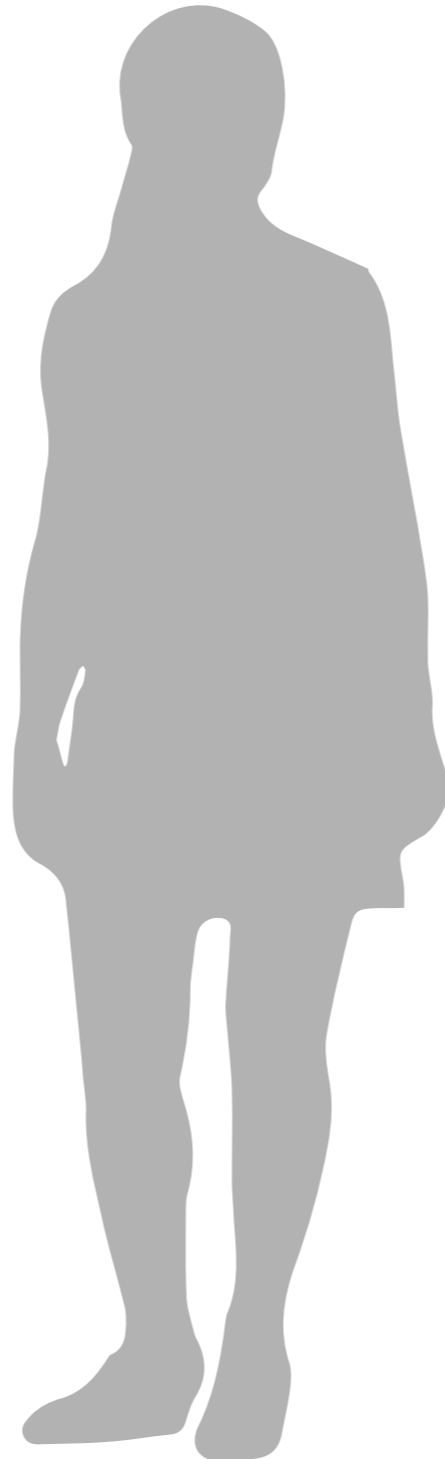

VISUAL DEMONSTRATES HOW PRINCIPLE APPLIED A TOTEM AS AN EXAMPLE

Principles : grouping

In any category, information is organised consistently; either by direction, destination type or proximity.

- DIRECTIONAL INFORMATION :**  
Information is arrow led and organised in counter-clockwise order, with destinations listed based on their proximity from the sign and followed by a pictogram or proximity indicator if appropriate.
- ORIENTATION INFORMATION :**  
Information is oriented north, with current location centred in view or emphasised by colour. Numbers indicate attractions, icons indicate facilities or access, and a pinpoint identifies your location on the plan. Legends list numbered items and icons displayed, in numeric and then alphabetical order.
- STATUTORY INFORMATION :**  
Information organised in order of category –mandatory (*must do*), prohibitive (*don't do*) and cautions (*beware/note*), and ideally paired with a pictogram which sits above text.
- DIVIDER LINES :**  
Where multiple information categories exist on a sign, these are grouped as above, and separated by a horizontal divider line.

**Note :** whilst these principles are based on best practices, some deviations may occur product to product based on content requirements or signage constraints.

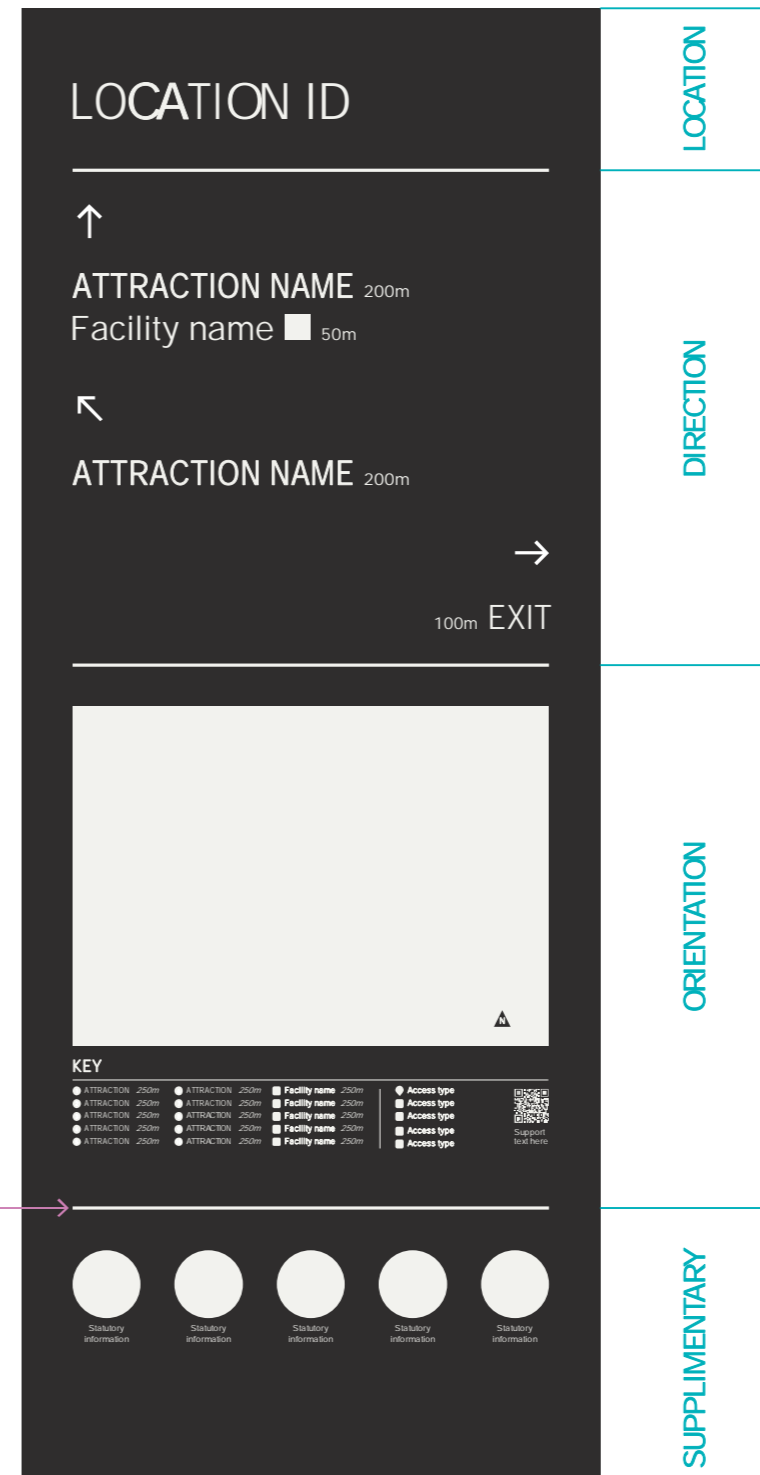

Divider lines break up groups of information

VISUAL DEMONSTRATES HOW PRINCIPLE APPLIED A TOTEM AS AN EXAMPLE

Principles : directional hierarchy

Content is organised by direction in counter-clockwise order left to right, destinations listed beneath arrows.

- Where multiple destinations exist in any given direction, these are organised in order of their proximity from the sign alphanumerically.
- Dedicated margins and spacing enables directional information to be displayed and listed clearly, with content being listed and aligned based on direction (either left or right).
- The scale of arrows, text, pictograms and proximity is determined by the x-height of the sign type. With arrows sitting above text, and text being followed by pictograms and then proximity.

Arrow hierarchy

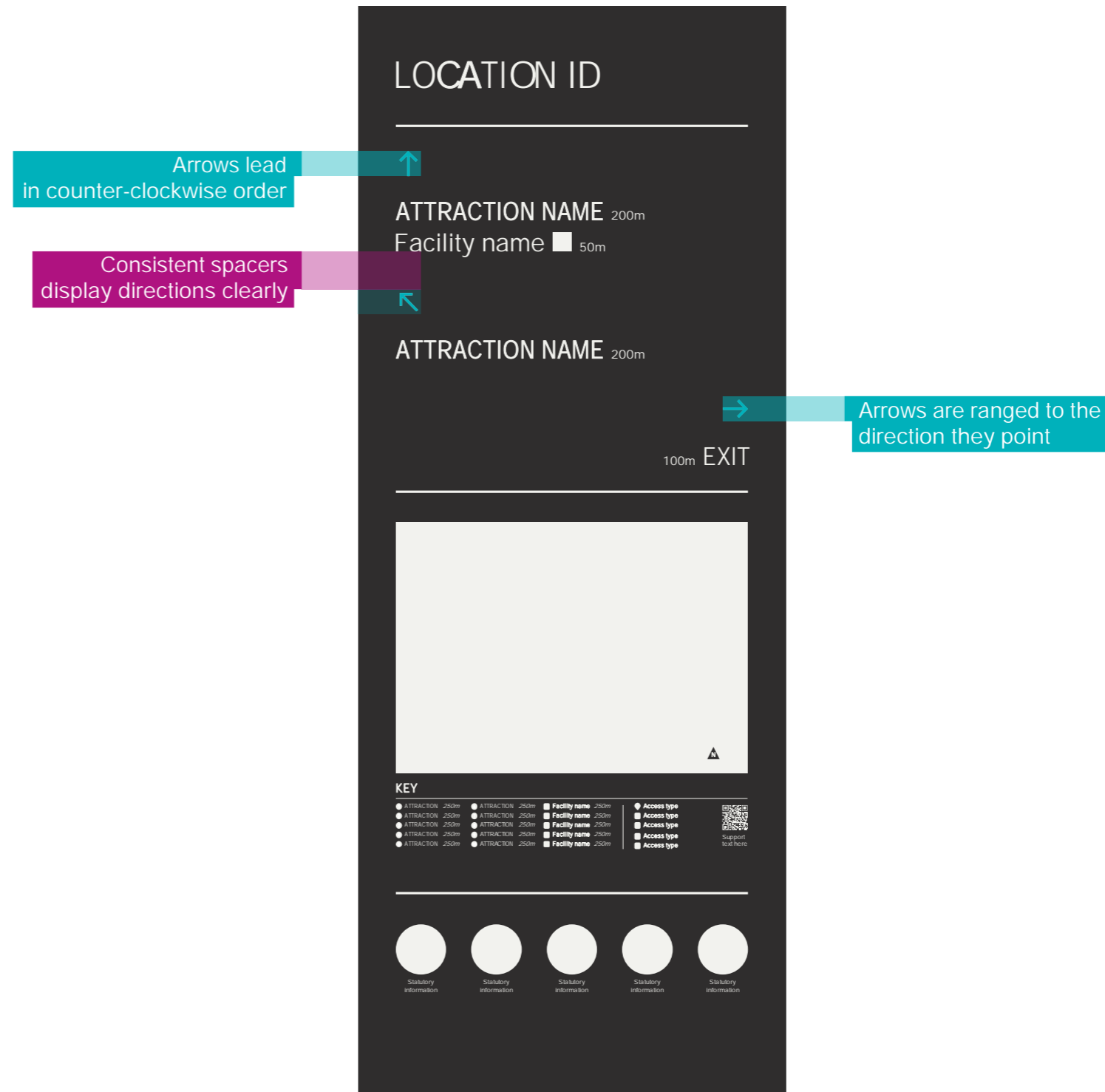
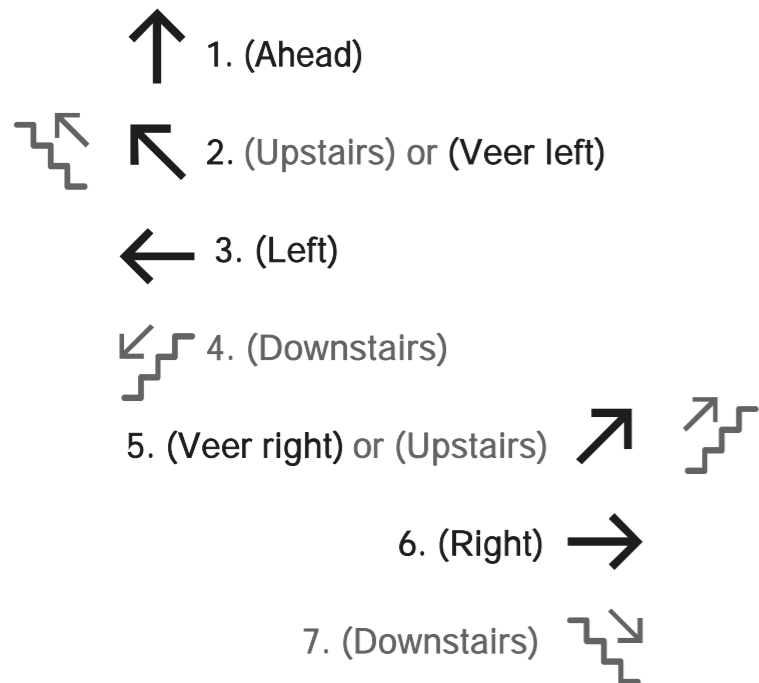

VISUAL DEMONSTRATES HOW PRINCIPLE APPLIED A TOTEM AS AN EXAMPLE



Principles : destination hierarchy

Where listed, destinations are ordered based on proximity to the sign or in order of category.

- Where multiple destinations exist in any given direction, these are organised in order of destination status, followed by their proximity from the sign. Where destinations are equal in status and proximity, these are listed alphabetically.
- Where multiple destinations exist in a legend, these are organised numerically, as shown on plan, or alphabetically if an icon, organised by category: access (entrances, lifts, ramps, stairs), facilities (cafe, lockers, shop, toilets), services (information point, parking, tickets), beyond the museum (city landmarks, station hub)

Destination status hierarchy

- ATTRACTION
- EXIT
- Point of interest
- Common area/facility

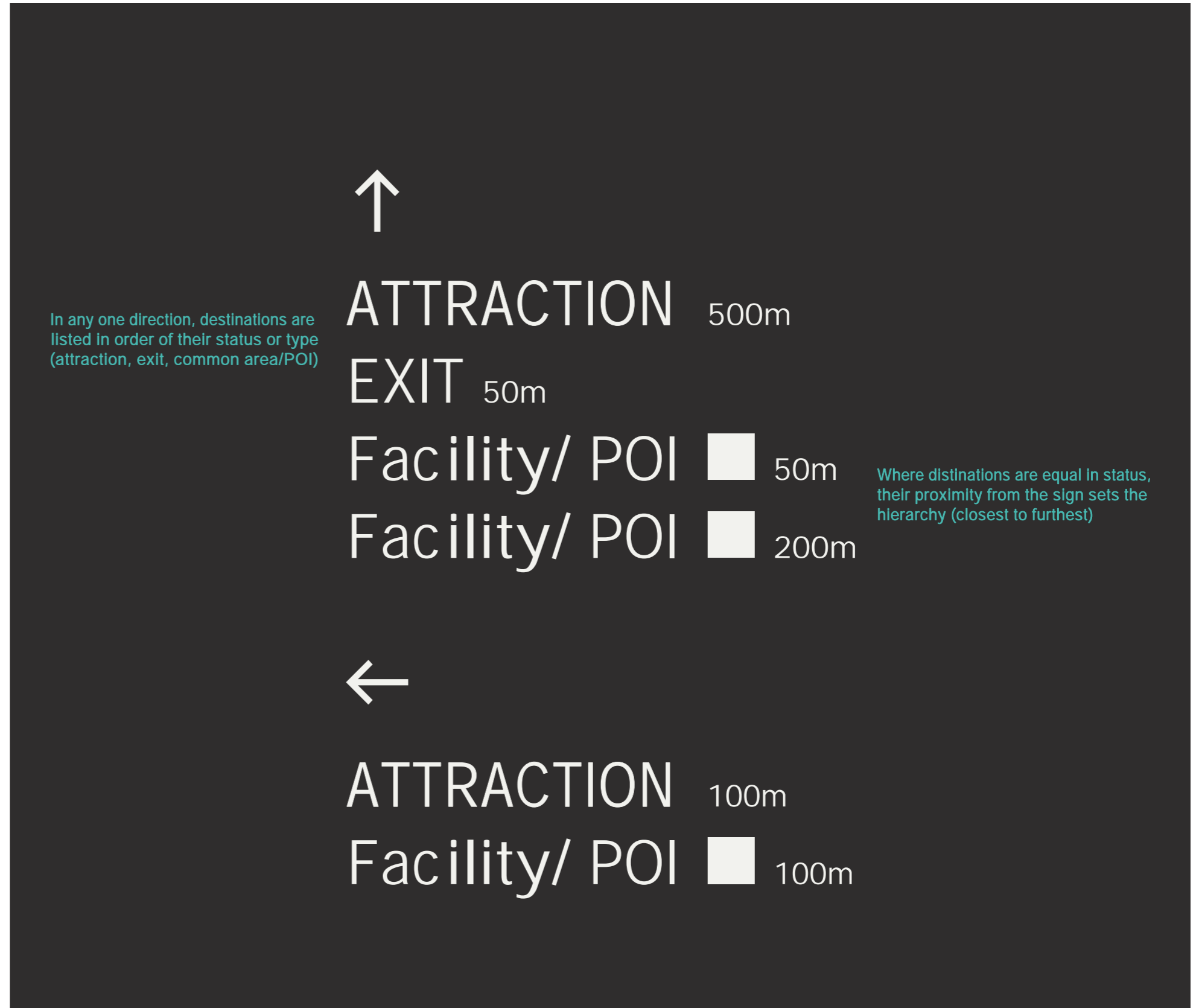

VISUAL DEMONSTRATES HOW PRINCIPLE APPLIED A TOTEM AS AN EXAMPLE

Principles : layout spacing

Content is formatted in consistent layouts across sign types, with divider lines, consistent alignment, clear margins and proportional spacing.

- Dedicated margins create clear spacing between content and fixing methods, as well as establish the outer alignment for content.
- Dividers and spacing buffers enable information to be stacked and listed, clearly distinguishing directions from destinations or mapping.

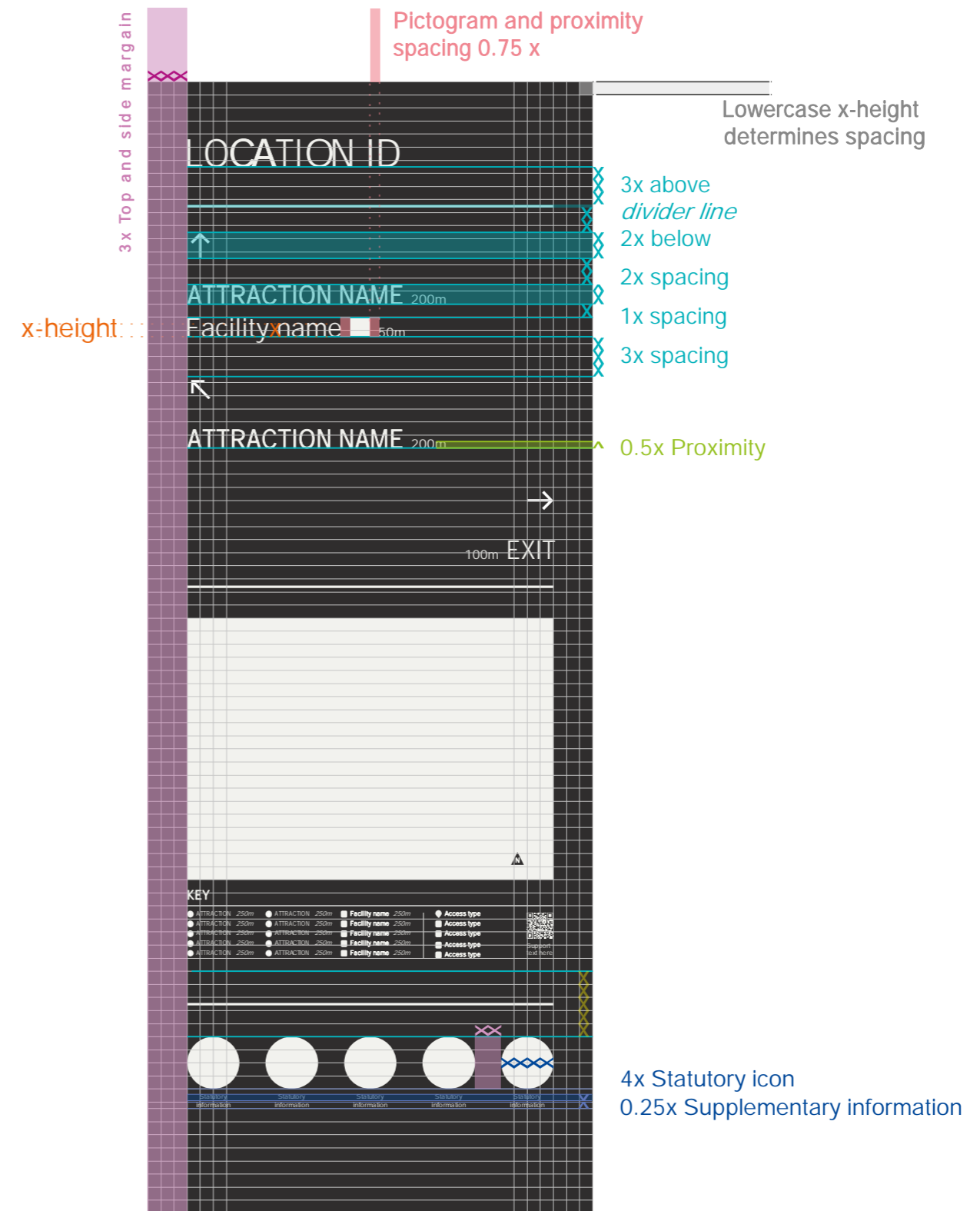

Note : x = lowercase x-height

VISUAL DEMONSTRATES HOW PRINCIPLE APPLIED A TOTEM AS AN EXAMPLE

Principles : typesetting

Typesetting is a unique part of the SMG brand identity. Wayfinding where possible adopts stylistic typesetting increasing coherency between brand and signage. Where needed in line weight, scale or orientation may be enhanced to suit the requirements of wayfinding where needed.

- **Signature typesetting (black to light weight)** is used for identification signage of the museum + areas unique to it:
  - Area name identifier = Upper case, V-aligned
  - Building identifier = Upper case, V-aligned
  - Attraction identifier = Upper case, H-aligned
  - Hall identifier = Upper case, H-or V-aligned
  - Museum identifier = Upper case H-or V-aligned.
- **Primary typesetting (regular/medium weight)** is used for identification signage of common areas, as well as for directional, informative or statutory signage:
  - Statutory info = Sentence case, centre-aligned
  - Overview info = Sentence case, left-aligned.
  - Facility direction = Sentence case, outer-aligned
  - Attraction direction = Sentence case, outer-aligned
  - Exit/Hall direction = Upper case, outer-aligned
  - Access identifier = Upper case, outer-aligned
- Where content is aligned vertically, it should be read from bottom up, and ideally with the baseline placed closest to the entrance.

Signature typesetting:  
For identification signage

Used on identification signage only, when identifying areas unique to the museum (halls, zones, attractions).

Typically illuminated, transitioning in weight (Black to Light).

May be displayed horizontal or vertical format.

Primary typesetting:  
Wayfinding signage

Used on directional, informative, statutory and exit signage, as well as identification of common areas only.

Typically one weight (Bold or Regular) in uppercase or sentence case dependent on content type.

May be displayed horizontally only.



# Thank you

Mima group  
Second Home Spitalfields  
68-80 Hanbury Street  
London E1 5JL

+44 (0) 20 7593 2900  
[hello@mimagroup.com](mailto:hello@mimagroup.com)

[www.mimagroup.com](http://www.mimagroup.com)



# Appendix : Museum identification

## Appendix : Museum identification intent

The intended placement of museum identification at Locomotion is currently under review, following an update to the architectural facade. The following pages show the original and alternative recommendation for identification placement. These are currently under review of the Science Museum Group.

No matter which option, the quantity, scale and materiality of the signage remains unchanged. Only orientation and colour is affected.

LOCOMOTION :

MAIN HALL (Existing)

Product type : STG Stencil Graphics Gigantic

Dimensions : 14150 x 1800 mm

Specifications : Self-adhesive vinyl  
Opaque white applied to reverse of glass

Reading range : 500+ m

x-Height : 1285 mm (1800 mm CAP)

Note : Identification is existing

MAIN HALL (facing railway)

Product type : STG Stencil Graphics Gigantic

Dimensions : 14150 x 1800 mm

Specifications : Self-adhesive vinyl  
Opaque white applied to reverse of glass

Reading range : 500+ m

x-Height : 1285 mm (1800 mm CAP)

Note : New identification to be applied 2.25m above F/L

LOCOMOTION

EXIT

ENTRANCE

MAIN HALL

LOCOMOTION

LOGO ID COLOUR :

SIGNAL WHITE  
RAL 9003

Recommended for  
best contrast against  
architectural finishes

**NEW HALL : APPROVED RECOMMENDATION**

**FRONT AND BACK FACADE**

Product type : STX Stencil Graphics Extra Big

Dimensions : 900 x 7100 mm lettering on facade  
Specifications : Painted lettering for external surface  
Opaque white  
Reading range : 250+ m  
x-Height : 642.5 mm (900 mm CAP)

**Note :** Horizontal identification to be applied 5.25m above F/L

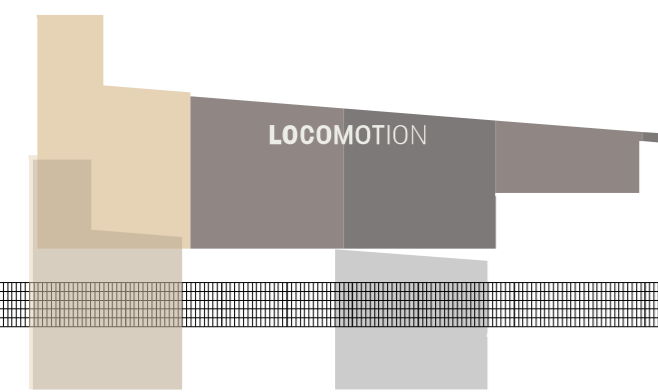
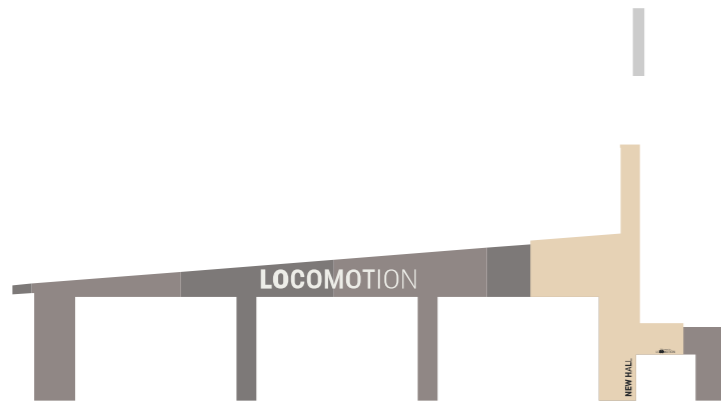

LOGO ID COLOUR :  
**SIGNAL WHITE**  
RAL 9003  
Recommended for best contrast against obsidian cladding finish

TEXT COLOUR :  
**GRAPHITE BLACK**  
RAL 9011  
Recommended for best contrast against cream cladding finish



- PRO:** ACCESSIBLE + LEGIBLE FROM ALL VIEWPOINTS
- PRO:** CONSISTENT ORIENTATION ACROSS SITE
- PRO:** CONSISTENT ID COLOUR ACROSS SITE
- PRO:** VISIBLE FROM ALL APPROACHES TO BUILDING

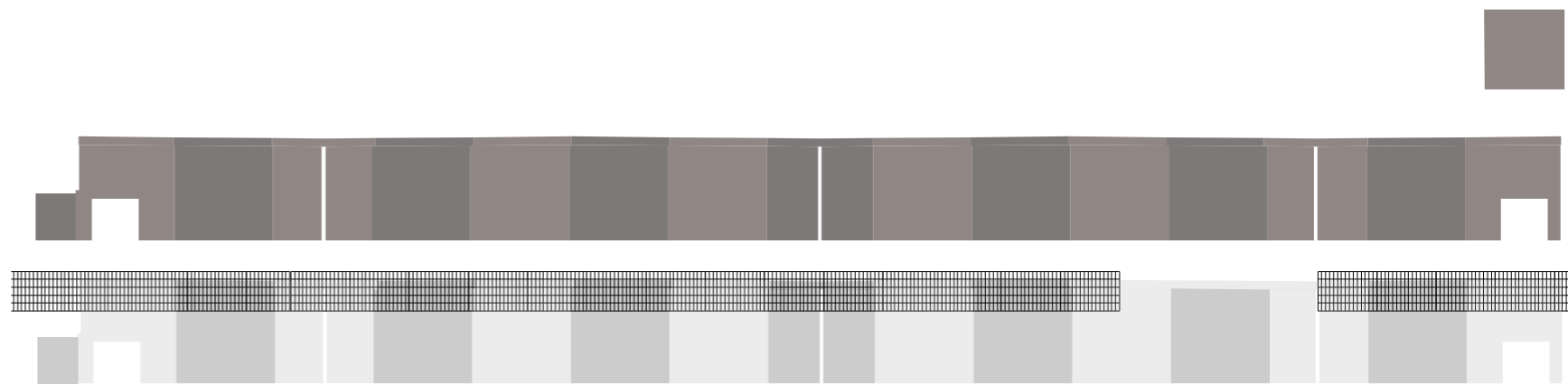



STATION APPROACH :

BRIDGE

Product type : STX Stencil Graphics Extra Big

Dimensions : 7100 x 900 mm

Specifications : Painted lettering for external surface  
Opaque white

Reading range : 250+ m

x-Height : 642.5 mm (900 mm CAP)

Note : Permission pending

GATE

Product type : PNG Panel Gate

Dimensions : ±1700 x ±1700 x 5 mm fixed gate panel

Specifications : Graphics applied to panelling  
Panelling mounted to both sides of gates

Reading range : 78 m (ID only)

x-Height : 175 mm (245 mm CAP) (ID only)



## Appendix : New Hall coordination

Following the most recent coordination meeting with AOC and the site visit with Nationwide, it has been agreed that the donor recognition panel will remain in the location shown in the tender issue, by the main entrance after the windows, and that a suspended panel per aisle will proceed for signage to direct towards toilets.

The following page uses elevations from the architect to demonstrate the principle of placement for these panels, which will be adjusted on site. Suspended panels will sit above interpretation, and below rod lighting at between 2.4–2.5m above F/L. Panels will be suspended from the beams behind CCTV cameras where applicable to avoid obstruction of sightlines.

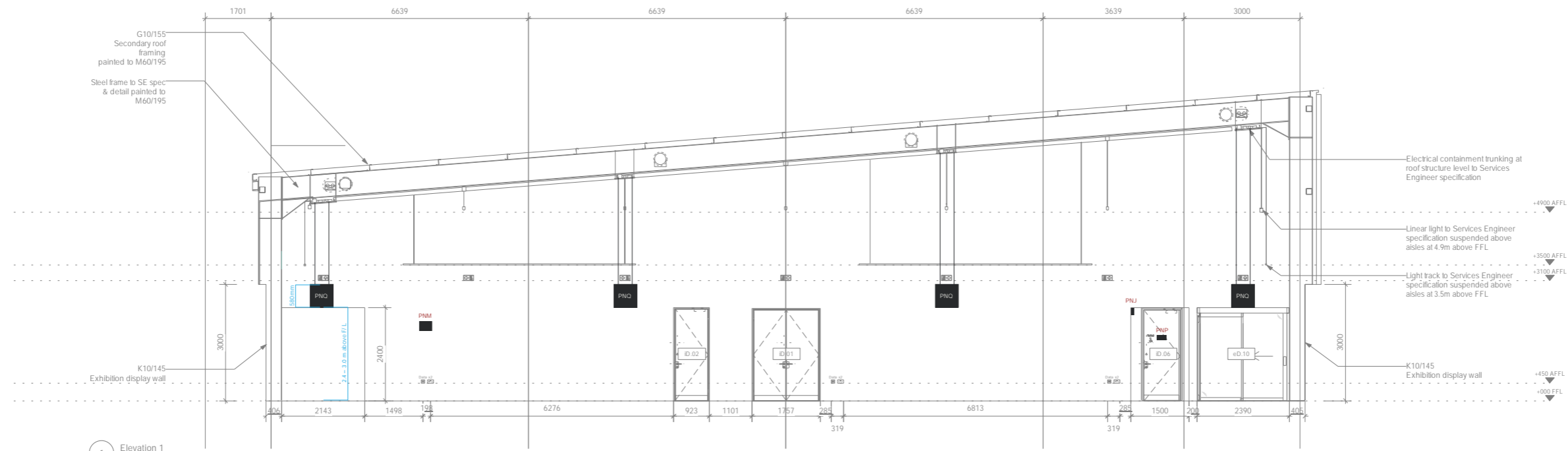

1 Elevation 1  
Scale: 1:50

**AOC** Architecture Ltd  
38-50 Pilbroad's Road London E2 9AP  
T: +44 20 7739 9950  
www.theaoc.co.uk studio@theaoc.co.uk

SCALE  
0 1 2 3 M

All dimensions in millimeters unless otherwise stated.  
All dimensions to be checked on site.  
Do not scale from this drawing except for planning purposes.  
Any errors to be reported to the architect immediately.  
Copyright reserved.

NOTES: All specifications and finishes as 'or similar approved'

**To all public areas:**  
All external cladding and secondary framing painted to RAL 7016 or RAL 7018 structural services painted to RAL 7016  
All the above to be painted RAL 9005 Signal white to match main lining of H02110

**Exposed Services:**  
All exposed services (ESP) services to be painted to RAL 9005 Signal white to match main lining of H02110

**Key:**  
G10: 100mm New Data Outer  
G11: 100mm Steel Deck  
G12: 100mm Steel Deck  
G13: 100mm Steel Deck  
G14: 100mm Steel Deck  
G15: 100mm Steel Deck  
G16: 100mm Steel Deck  
G17: 100mm Steel Deck  
G18: 100mm Steel Deck  
G19: 100mm Steel Deck  
G20: 100mm Steel Deck

No.	Revision / Issue	Drawn by	Checked by	Date	No.	Revision / Issue	Drawn by	Checked by	Date
PL1	Stage 4 Issue	AM	HS	17.04.23					
T2	Stage 3 Tender Issue	HS	GS	24.03.22					
T1	Stage 3 Tender Issue	JK	GS	04.03.22					
PH	Planning Issue	JK	GS	07.02.22					

Project Title  
**261 SMG Locomotion Building 2**  
Small Retail Industrial Estate, Station DL4 2HE

Drawing Name: PROPOSED Internal Elevations, collections space 1  
Drawing Status: INFORMATION  
Scale: 1:50 @ A1 / 1:100 @ A3  
Drawing No: 261\_AD\_300  
Rev: PL1

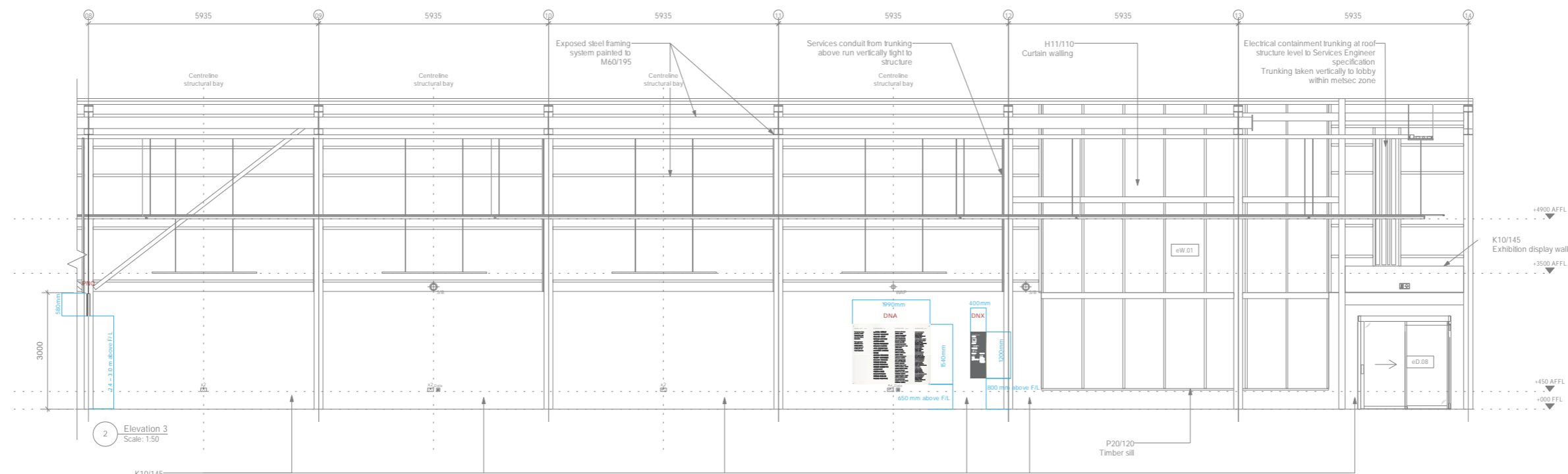

2 Elevation 3  
Scale: 1:50

**AOC** Architecture Ltd  
38-50 Pilbroad's Road London E2 9AP  
T: +44 20 7739 9950  
www.theaoc.co.uk studio@theaoc.co.uk

SCALE  
0 1 2 3 M

All dimensions in millimeters unless otherwise stated.  
All dimensions to be checked on site.  
Do not scale from this drawing except for planning purposes.  
Any errors to be reported to the architect immediately.  
Copyright reserved.

NOTES: All specifications and finishes as 'or similar approved'

**To all public areas:**  
All external cladding and secondary framing painted to RAL 7016 or RAL 7018 structural services painted to RAL 7016  
All the above to be painted RAL 9005 Signal white to match main lining of H02110

**Exposed Services:**  
All exposed services (ESP) services to be painted to RAL 9005 Signal white to match main lining of H02110

**Key:**  
G10: 100mm New Data Outer  
G11: 100mm Steel Deck  
G12: 100mm Steel Deck  
G13: 100mm Steel Deck  
G14: 100mm Steel Deck  
G15: 100mm Steel Deck  
G16: 100mm Steel Deck  
G17: 100mm Steel Deck  
G18: 100mm Steel Deck  
G19: 100mm Steel Deck  
G20: 100mm Steel Deck

No.	Revision / Issue	Drawn by	Checked by	Date	No.	Revision / Issue	Drawn by	Checked by	Date
PL1	Stage 4 Issue	AM	HS	17.04.23					
T2	Stage 3 Tender Issue	HS	GS	24.03.22					
T1	Stage 3 Tender Issue	JK	GS	04.03.22					
PH	Planning Issue	JK	GS	07.02.22					

Project Title  
**261 SMG Locomotion Building 2**  
Small Retail Industrial Estate, Station DL4 2HE

Drawing Name: PROPOSED Internal Elevations, collections space 2  
Drawing Status: INFORMATION  
Scale: 1:50 @ A1 / 1:100 @ A3  
Drawing No: 261\_AD\_301  
Rev: PL1

**NATIONAL RAILWAY MUSEUM AND LOCOMOTION**  
DOCUMENT CONTROL



Version	Date of Issue	Document title	Document changes
1.0	23.06.2023	MIMA-2355-04-SMG-TD-23	Issued for tender
2.0	24.10.2023	MIMA-2355-05-LCM-TD-23	Updated Locomotion issue
2.1	13.12.2023	MIMA-2355-05-LCM-TD-23	Updated planning permission issue

**Authored by**  
Houri Boughosyan, Senior Wayfinding Lead

**Approved by**  
Chris Girling, Head of Wayfinding

