

**PLEASE NOTE**

Position of Gas and Electric meter box positions have been moved to frontage if shown on neighbouring drive.

PLEASE ONLY USE HOUSETYPE DRAWING POSITIONS

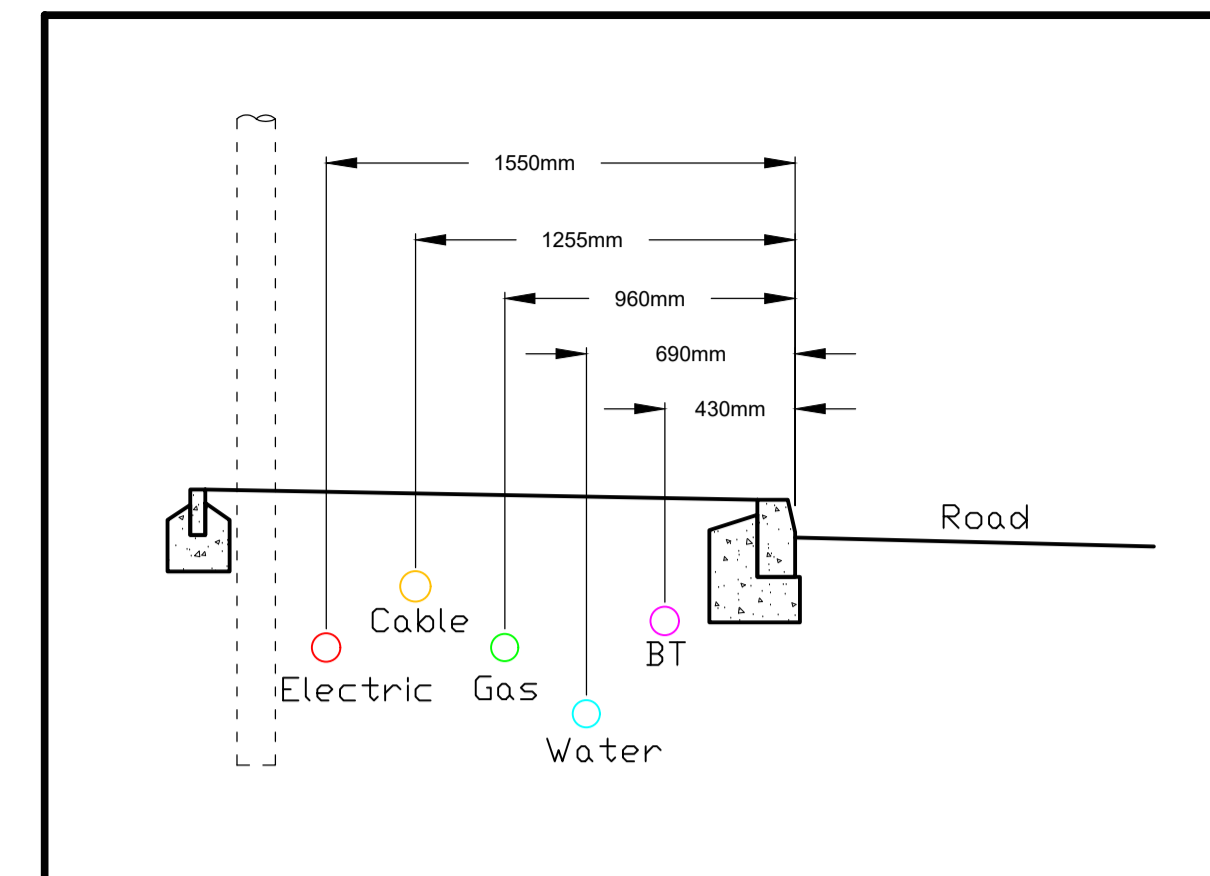

**PLEASE ENSURE**

Service boxes and Chamber covers to be located outside of any tactile crossing areas.

Trench backfill below formation within the Highway to be of an approved granular material (approved by Authority Inspector - this includes service trenches).

PLEASE allow for 25 Fibre Boxes.

**Street Lights**

Please refer to the plan showing street light positions, the Tendering Contractor to ensure all duct crossings are included within the Tender



HAW WOOD

RESIDENTIAL  
PARCEL 4

A	04.12.23	Layout updated	DM
REV	DATE	DESCRIPTION	DRAWN

PROJECT	Cribbs - PhB
TITLE	Combined Services

**Taylor Wimpey Bristol**  
 Ground Floor  
 730 Waterside Drive  
 Aztec West  
 Almondsbury  
 Bristol BS31 2AU  
 T 01454 628400  
 F 01454 628401  
 DX 124854 Almondsbury 3  
 www.taylorwimpey.com  
 NHBC REG No 76463



DRN	D Morgan	SCALE	LAND CODE	DRAWING NUMBER	REV
DATE	Aug 23	1:500	21484	08-01	A