



▲ CLAY PROFILE TILE ROOF SYSTEMS



CONTENTS

- 6 CLAY PROFILE TILE ROOF SYSTEMS
- 8 INNOVATION IN CLAY
- 10 LINCOLN PANTILE
- 16 EDEN TRADITIONAL CLAY PANTILE
- 20 DETAILING CLAY PROFILE TILE ROOF SYSTEMS
- 22 BASE LAYERS
- 24 FITTINGS & ACCESSORIES
- 26 PROPERTIES & PERFORMANCE
- 28 DESIGN DETAILS
- 36 HERE TO HELP

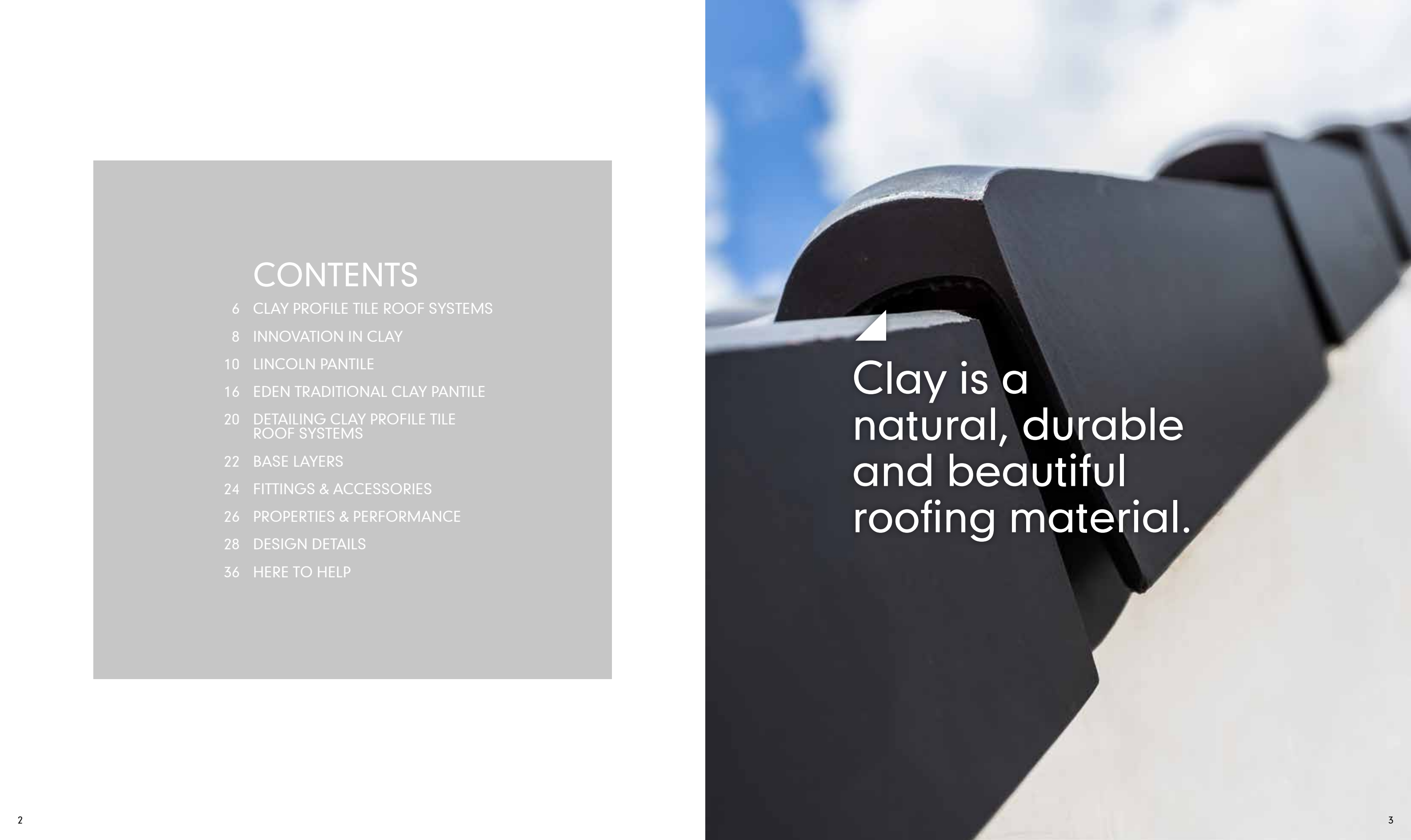

▲
Clay is a natural, durable and beautiful roofing material.

▲ Traditional clay has been used to cover roofs in Britain for over eight hundred years, but now precision manufacture and interlocking technology allows the beautiful, natural warmth of clay to be combined with a range of profile options, high performance and ease of installation.



CLAY PROFILE TILE ROOF SYSTEMS

- ▲ We offer the most comprehensive roof system on the market today, underwritten by a 15 year warranty. Our complete, one-source roof system, gives levels of accountability and product integration that reduce specifier and contractor design and installation liability. More elements guaranteed to work seamlessly together, give you more time to focus on design and management of your project, complete peace of mind and, of course, better, easier-to-install, more durable, lower maintenance roofs.

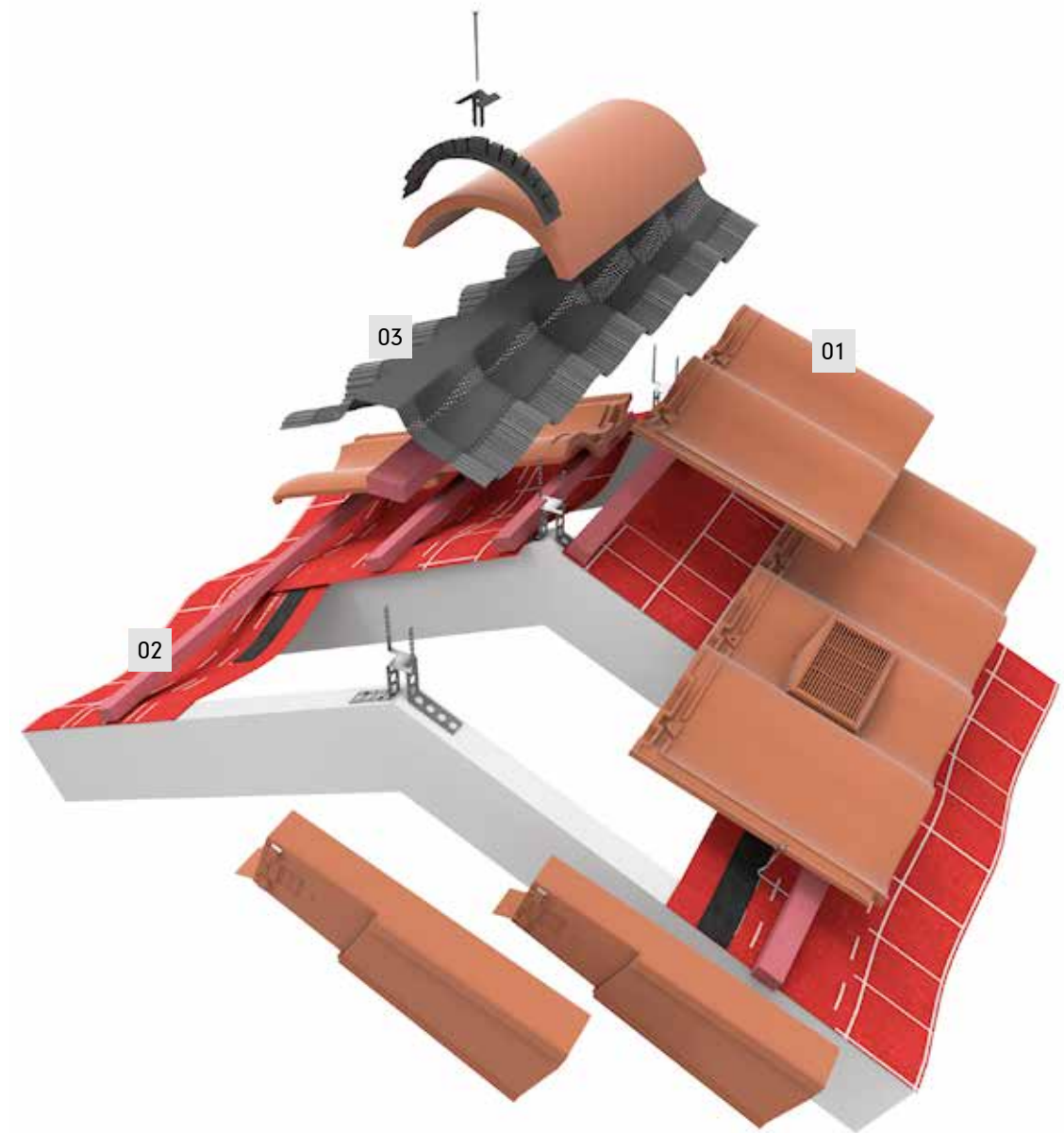

01/ ROOF COVERINGS

A range of clay profile tiles to suit every sector, pitch, geographical location and aesthetic requirement: at the same time complying with BS 5534 and BS 5250 and fully integrating with our base layers and dry fix systems to create a complete roof system.

- ▲ Clay profile tile range (pages 10-19)
- ▲ Properties and performance (pages 26-27)
- ▲ Case studies pages (14-15)

02/ BASE LAYERS

With Universal permeable or non-breathable fully taped underlay and JB Red pre-graded BBA-certified battens, we offer BS 5534-compliant NHBC approved base layers that work seamlessly with all the other elements of our roof systems.

- ▲ Universal underlays (page 22)
- ▲ JB Red battens (page 23)

03/ DETAILING

Dry fix BS 5534 and BS 5250-compliant systems for eaves, verge, valley hip, ridge abutment and other areas. These systems are made from high quality materials and tested together to work with our clay plain tile and other roof coverings to give secure, weathertight and durable finishing and detailing for our roof systems.

- ▲ Dry fix and ventilation systems (pages 20-21)
- ▲ Fittings and accessories (pages 24)
- ▲ Design details pages (pages 28-35)

KNOWLEDGE

A key part of our roof system is ease of access to tools and knowledge that make the design, specification and fixing process easier and faster. Our suite of free-to-use online tools is designed to get our knowledge into your designs and specs quickly and easily.

- ▲ Resources (pages 36-37)

WARRANTY

Our 15 year warranty covers more pitched roofing elements than any other manufacturer and gives the ultimate assurance that our integrated roofing solutions can be specified and installed with complete confidence.

- ▲ For more information visit marley.co.uk/resources



▲ Innovation in clay

Clay profile tiles harness the beauty and warmth of natural clay and engineered high performance in one elegant package, giving specifier, installer and homeowner alike the best of all worlds.

Our extensive range contains colour and profile options which meet the aesthetic and performance demands of all types of roofing applications.

- ▲ BES 6001 'Excellent' rating and A+ rated in the BRE Green Guide
- ▲ Durable, natural material
- ▲ Full range of colours and finishes
- ▲ 12.5° low pitch options
- ▲ Full range of fittings and accessories
- ▲ Independent carbon footprint certification
- ▲ Meet BS 5534 and NBHC technical standards

LINCOLN

CLAY PROFILE PANTILES

lowpitch



Beautiful, large format clay profile pantiles bring durability and unrivalled weather protection to new and refurbishment projects. The Lincoln clay pantile features a completely open-gauge design, making it quick and easy to install.

Lincoln combines the bold and beautiful curves of traditional clay pantiles with all the installation simplicity and speed required for today's roofs. This means that Lincoln affords the rich appeal of natural, clay pantiled roofs, a thin leading edge and a beauty that matures over time.

TECHNICAL TOOLKIT

Marley provides a comprehensive technical service and a range of online tools to ensure design performance and compliance to the latest British Standards and NHBC technical guidelines. These services include:

- ▲ Fixing specifications: marley.co.uk/tilefix
- ▲ NBS clauses: marley.co.uk/specrite
- ▲ CAD details: marley.co.uk/cad
- ▲ BIM models: marley.co.uk/bim

For more information on the recent update to the British Standard for Slating and Tiling (BS 5534) and how it might affect your project, please visit marley.co.uk/BS5534

COLOUR AVAILABILITY

See pages 12-13 for more detailed colour panels.



Rustic Red (F)

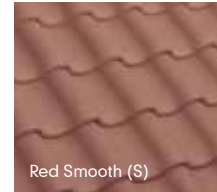

Red Smooth (S)

Key: (F) Fine sanded finish (S) Smooth finish

TECHNICAL DATA

For a full technical specification and support please contact our team of experts on 01283 722330

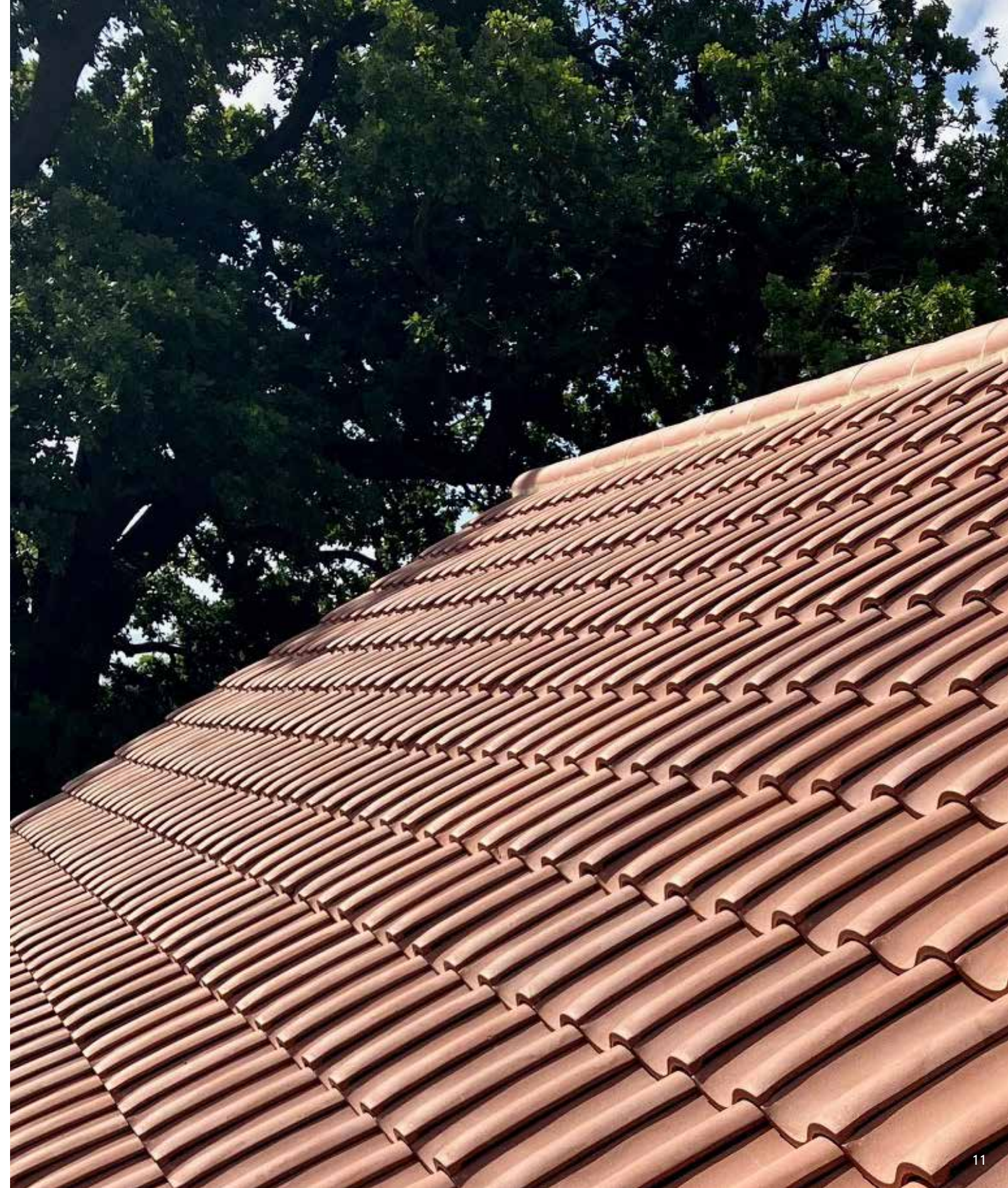

LINCOLN RUSTIC RED
FINE SANDED FINISH



LINCOLN RED SMOOTH
SMOOTH FINISH



DOVECOTE & TEVERSAL BARNES

CASE STUDY



Traditional pantiles are really cumbersome to install, so the Lincoln is a welcome alternative and one we would definitely use again. We couldn't believe how much quicker and easier to install the tiles were, yet the finished roof still has the beautiful curves and rustic charm of a traditional pantile roof."

ADRIAN SMITH

Set in the historic village of Teversal in Nottinghamshire, Dovecote and Teversal Barnes are an important part of the area's agricultural heritage.

Although the original pantiles had been retained when the barns were converted to residential use, over time the historic roofs had fallen into a state of disrepair and Adrian Smith Builders was appointed to complete a full roof refurbishment on both of the barns.

Set in a conservation area, with many listed buildings dating back as far as the 12th century, traditional red clay pantiles are an important part of the local vernacular in Teversal and are often dictated by planning. With a roof structure that was far from flat, Adrian Smith recommended a new type of pantile that would be easier to install, but still give the traditional curved rustic aesthetic dictated by planning. As a result, the Lincoln interlocking pantile in Rustic Red was chosen for the project.

▲ Find more case studies at marley.co.uk/casestudies

PROJECT INFORMATION

Location/
Nottinghamshire

Application/
Residential

Product/
Lincoln (Rustic Red)

Specifier/
Adrian Smith Builders

EDEN

TRADITIONAL CLAY PANTILES

The newest, exciting addition to our classic clay range combines carefully considered design with a traditional feel and beautiful look of a clay pantile. Eden takes the hassle out of guesswork and intensive labour out of laying clay pantiles. The low minimum pitch offers versatility and our Solofix clips provide an easier fit and compliance with BS 5534. New design features improve on the quirks of a classic pantile.

The advanced design of the Eden Pantile makes laying of this true traditional pantile quicker and easier than ever before whilst preserving the charm and character of a traditional clay pantile.

TECHNICAL TOOLKIT

Marley provides a comprehensive technical service and a range of online tools to ensure design performance and compliance to the latest British Standards and NHBC technical guidelines. These services include:

- ▲ Fixing specifications: marley.co.uk/tilefix
- ▲ NBS clauses: marley.co.uk/specrite
- ▲ CAD details: marley.co.uk/cad
- ▲ BIM models: marley.co.uk/bim

For more information on the recent update to the British Standard for Slating and Tiling (BS 5534) and how it might affect your project, please visit marley.co.uk/BS5534



COLOUR AVAILABILITY

See pages 10-11 for more detailed colour panels.



Key (V) Variable finish (S) Smooth finish

TECHNICAL DATA

For a full technical specification and support please contact on our team of experts on 01283 722330



EDEN RUSTIC RED
VARIABLE FINISH



EDEN RED SMOOTH
SMOOTH FINISH



DETAILING CLAY PROFILE TILE ROOF SYSTEMS

▲ We at Marley design our roofing products as holistic systems. Our dry fix and ventilation solutions are a key part of our roof system, enabling flexibility in design and detailing; offering weatherproofing, security and refined aesthetics, as well as providing excellent levels of ventilation.

They are also quick, straightforward and economical to install, and for the building owner, they require minimal ongoing maintenance but give maximum durability and long life.

MARLEY DRY FIX SYSTEMS

To improve the speed and economy of roof construction, a choice of high performance, maintenance-free dry fix systems are offered to suit ridge, verge, hip and valley details providing easy to fix alternatives to traditional mortar bedding. When correctly installed, they are designed to satisfy the requirements of BS 5534 'Code of practice for slating and tiling' with respect to the mechanical fixing of roof fittings to resist wind uplift and the provision of a weathertight roof.

Available systems: Universal RidgeFast, Universal HipFast, Dry Hip system, Dry ridge and mono ridge, Universal plain tile dry verge system, Cloak verge tiles, Universal GRP Dry valley, Bonding gutters.

MARLEY VENTILATION SYSTEMS

To assist the designer in meeting the requirements of the Building Regulations, Marley has developed a range of ventilation accessories that combine discreet and aesthetic solutions with the highly efficient removal of moisture-laden air and gases. This comprehensive range is designed to ventilate roof voids with terminals for the ridge and roof, with connection to mechanical extract systems and soil vent pipes, allowing easy provision of precise amounts of free airspace.

Available systems: Universal eaves ventilation systems (10 and 25mm), Universal RidgeFast, Universal HipFast, Ventilated dry ridge and mono ridge, Ridge vent terminals, In-line vents.



BASE LAYERS

UNDERLAYS & BATTENS

FOR ROOF SYSTEMS

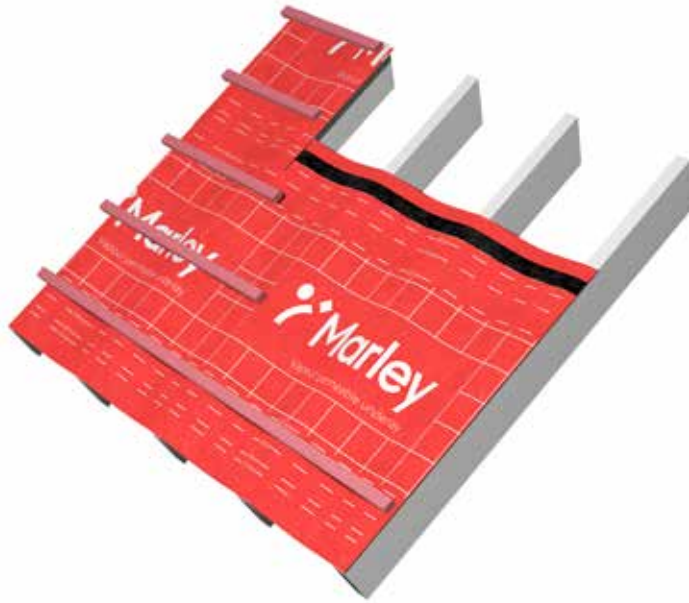

UNIVERSAL VAPOUR PERMEABLE UNDERLAY

Universal vapour permeable underlay is a lightweight, high performance breathable membrane for pitched roofs. Supplied in 1m x 50m rolls with integrated tape for sealing laps, the underlay is fully compliant to BS 5534 and suitable for all UK wind zones 1-5.

Universal vapour permeable underlay is designed to integrate seamlessly within a full Marley roof system and provides an additional means of ventilation to meet the requirements of BS 5250*.

* Consideration must be given to the type of roof covering used, which will influence the ventilation requirements. For further info, please contact the Marley technical department.

BENEFITS

- ▲ Vapour permeable
- ▲ High tensile and tear strength
- ▲ Clean and easy to handle
- ▲ Durable
- ▲ UV resistant
- ▲ BBA approved – Certificate No. 18/5521
- ▲ Integrated tape for sealing laps
- ▲ Guidance lines for minimum laps

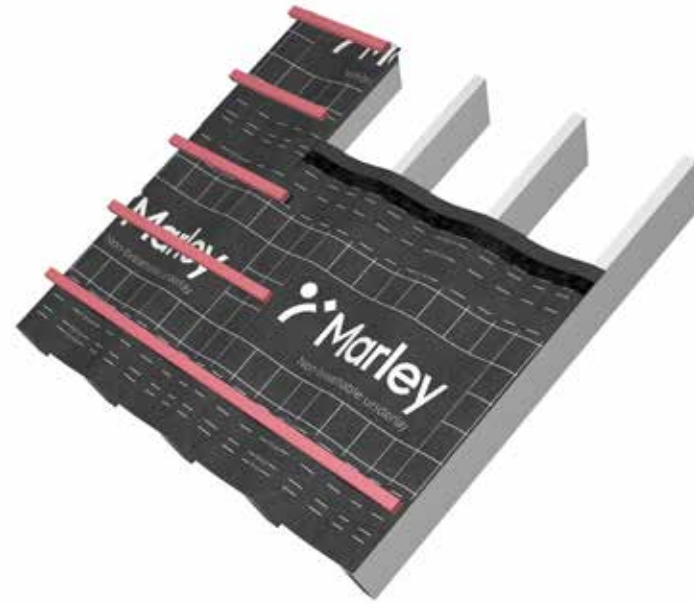

UNIVERSAL NON-BREATHABLE UNDERLAY

Universal non-breathable underlay is a lightweight, high performance membrane for pitched roofs. Supplied in 1m x 45m rolls with integrated tape for sealing laps, the underlay is fully compliant to BS 5534 and suitable for all UK wind zones 1-5.

Universal non-breathable underlay is designed to integrate seamlessly within a full Marley roof system and is suitable for roofs with traditional ventilation products or ventilated batten cavities.

BENEFITS

- ▲ Non-breathable
- ▲ High tensile and tear strength
- ▲ Clean and easy to handle
- ▲ Durable
- ▲ UV resistant
- ▲ BBA approved – Certificate no. 18/5519
- ▲ Lightweight alternative to traditional IF
- ▲ Integrated tape for sealing laps
- ▲ Guidance lines for minimum laps

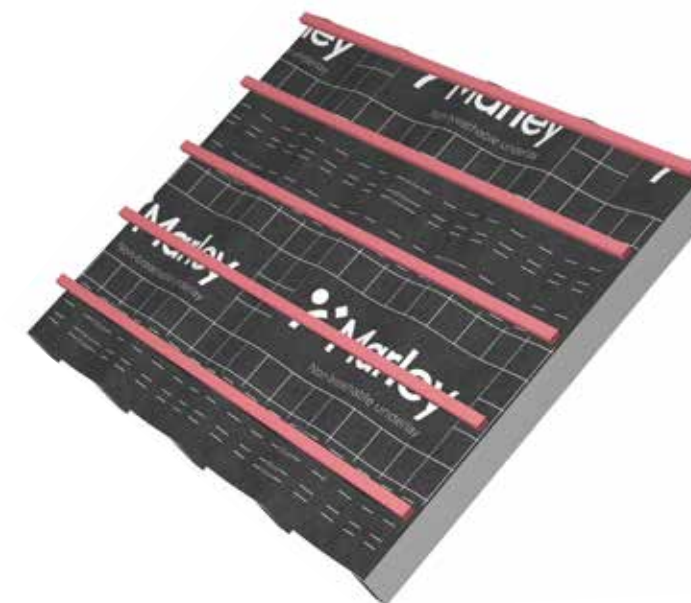

JB RED

JB Red is a high quality roofing batten and the first fully pre-graded batten available to the roofing industry.

JB Red completely meets the NHBC requirements for fully graded roofing battens. Its RED colour means that it is highly visible on site, therefore Local Authority Building Control, NHBC and other inspectors can see that high quality, pre-graded and compliant battens have been used.

All JB Red has full chain of custody (FSC or PEFC) certification and is available in both 25 x 38mm and 25 x 50mm sizes.

BENEFITS

- ▲ Pre-graded to all the strength requirements of BS 5534 for roofing battens.
- ▲ Marked according to BS 5534 showing supplier name, origin/species, grade (BS 5534) and size.
- ▲ The product and process is UKAS third party assessed by the BBA with a BBA Agrément certificate.

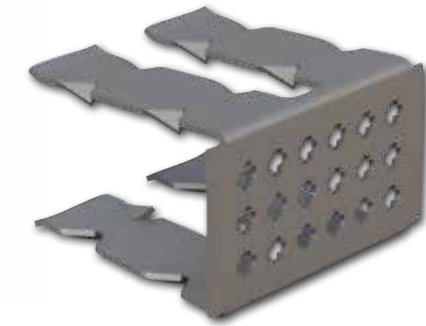

▲ JB Red is LABC registered detail and is approved for use by local authorities.

▲ JB Red carries full product liability insurance.

▲ Manufactured from slow grown, high grade timber, selected from the approved species within.

▲ BS 5534, typically European Redwood (PNSY) or European Whitewood (WPCA).

▲ Only kiln dried sideboards are used to ensure stability and dimensional accuracy.

▲ Treated to BS 8417 Usage Class 2, using Koppers MicroPro® with a unique Red Colour.

▲ Carries 60 year lifetime guarantee against insect attack and wood rotting fungi (when installed correctly in accordance with the requirements of Usage Class 2).

▲ Packaged in easy to handle bundles of 10.

BATTEN END CLIPS

These are for use with all dry verge units. Easily fitted to the batten end, they provide easy, fast and positive fixing of dry verge units to the batten end. Compliant with BS 8612.

FITTINGS & ACCESSORIES FOR CLAY PROFILE TILES

All products can be installed in line with the latest BS 5534 'Code of Practice for Slating and Tiling' and NHBC Technical Standards.

LINCOLN FITTINGS

Available in Rustic Red and Natural Red.

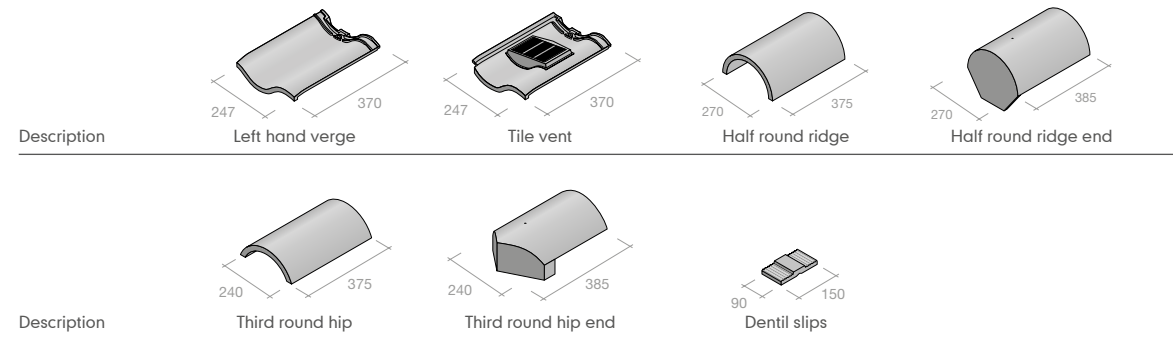

EDEN FITTINGS

Available in Rustic Red and Natural Red.

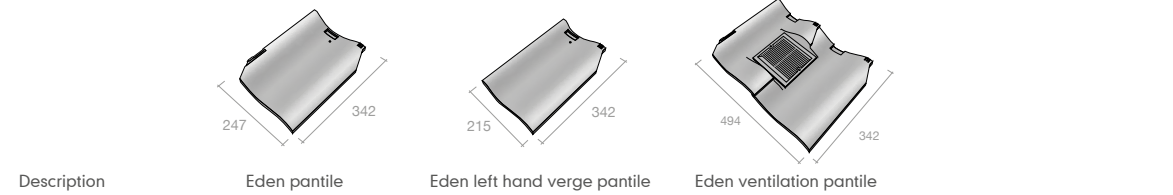

Note: All measurements in mm.

SERVICES

Marley offer a full range of technical and online advice services, including NBS and fixing specifications, which will help you meet the requirements of BS 5534.

- ▲ Fixing specifications marley.co.uk/tilefix
- ▲ NBS clauses marley.co.uk/specrite

MORTAR BEDDED SECURITY FIXING

Under BS 5534, the use of mortar as a sole means of fixing roof tiles and fittings is insufficient. Not only should careful consideration be given to the creation of a suitable roof mortar through the correct sand and cement mix, but tiles or fittings bedded with this mortar must also be accompanied by a mechanical fix.



MORTAR BEDDED SECURITY HIP

Mechanical fixing system for mortar bedded ridge hip, helping house builders and contractors meet British Standards and NHBC guidelines.

Watch a quick video on mortar bedded mechanical fixing at marley.co.uk/securityhip



MORTAR BEDDED SECURITY RIDGE

Mechanical fixing system for mortar bedded ridge ridges, helping house builders and contractors meet British Standards and NHBC guidelines.

Watch a quick video on mortar bedded mechanical fixing at marley.co.uk/securityridge

DRY FIX SOLUTIONS

Avoiding mortar with its associated risks and maintenance will always be best practice, and the changes to BS 5534 should assist in the continued adoption of dry fix.

For a mortar and maintenance free mechanical fix, Marley also offers a range of high performance dry fix solutions, including ridge and hip systems that are able to contribute towards ventilation to meet the requirements of BS 5250.



MORE ABOUT OUR DRY FIX SYSTEMS

Our website contains further information about dry fix and ventilation solutions, including the Universal range, which not only works with our roof tiles but those of other manufacturers too: www.marley.co.uk/dryfix

PROPERTIES & PERFORMANCE

ANATOMY OF LINCOLN PROFILE CLAY TILE



FEATURES OF CLAY PROFILE TILES

- ▲ Low pitch options down to 12.5°
- ▲ BES 6001 Certified 'Excellent'
- ▲ Can achieve A+ in the BRE Green Guide
- ▲ 100% recyclable

AUTHORITY

Marley clay profile tiles are manufactured to BS EN 1304 'Clay roofing tiles for discontinuous laying – Product definitions and specifications', operating a quality management system meeting the requirements of BS EN ISO 9001 'Quality Management Systems – requirements'.

Additionally, the manufacturing plant operates an environmental management system, in line with BS EN ISO 14001 'Environmental management systems – Specification with guidance for use' and Health and Safety Standard OHSAS 18001, working towards BS EN ISO 45001 certification.

Marley clay profile tiles are UKCA and CE marked in line with the Construction Product Regulation (marley.co.uk/ce). They are also rated 'Excellent' in the BES 6001 Framework Standard for the Responsible Sourcing of Construction Products.

RECYCLABILITY

At end of life, clay profile tiles can be reused or crushed and used as aggregate without the need for further processing. As a natural product, no special disposal considerations are required.

COMPOSITION AND MANUFACTURE

The tiles are machine moulded, dried and fired in gas fired tunnel kilns, using an advanced computer controlled system. This ensures that the products are made to exact tolerances in shape, size, colour and strength.

PERFORMANCE

Marley clay profile tiles are tested for resistance to wind driven rain and meet the requirements of BS 5534 'Code of practice for slating and tiling (including shingles)' with respect to wind loading, when fixed in accordance with our recommendations.

STRENGTH AND DURABILITY

Marley clay profile tiles are well vitrified and do not delaminate on weathering. They are also extremely strong, with a transverse strength well in excess of the 600N minimum requirement in BS EN 1304.

FIRE RESISTANCE

Marley clay profile tiles are non-combustible and meet the requirements for external fire performance without the need for further testing in accordance with Class B roof of BS EN 13501-5 using data from external exposure to fire roof tests (BS 476-3) as defined in ENV 1187. There are no restrictions on their use under the Building Regulations and are designated AA in Table A5 of Appendix A, Approved Document B, 'Fire Safety'.

ENVIRONMENTAL EFFECTS

THERMAL

Unaffected by extremes of temperature. Tiles should be laid with a slight gap (1-5mm) to accommodate any movement induced by changes in temperature.

The thermal resistance (R) of Marley clay tiles when dry is 0.013m²K/W.

For the purpose of thermal transmittance calculations, the preceding 'R' values should be substituted by a figure of 0.12m²K/W which includes the roof covering and the airspace behind the tiles or slates. An 'R' value of 0.020m²K/W should be added for the roof underlay.

FROST

Unaffected by frost, and meets the requirements of BS EN 1304 Annex A when tested to EN 539-2 in accordance with national requirements.

SUNLIGHT

Clay tiles do not fade and are unaffected by prolonged exposure to UV and sunlight.

ATMOSPHERIC POLLUTION

Suitable for all rural, marine and normal industrial environments. Avoid discharge of gases or liquids from chemical processes onto the surface of the tiles. Resistant to all but the most highly polluted atmospheres, where sulphur dioxide levels exceed 70 micrograms/m³ of air.

ELECTRICITY

Marley clay tiles are electronically insulating. Reference should be made to BS 6651 for recommendations on the protection of buildings against lightning strikes.

BIOLOGICAL EFFECTS

BIRDS AND RODENTS

Not affected or degraded by birds, rodents or insects.

MOSSES AND LICHENS

Water absorption of Marley clay plain tiles is very low, making their surface less likely to support growth of mosses and lichens, unless promoted by local environmental factors such as overhanging trees. Removal may only be required if growth is sufficient to restrict the drainage of water from the roof.

HEALTH AND SAFETY

When cutting tiles using an angle grinder, measures to reduce the effect of dust should be taken in accordance with the HSE Guidance Note EH 40 'Occupational Exposure Limits', EH 44 'Dust in the workplace: general principles of protection' and HSE Guidance Note EH59/2 (Respiratory Crystalline Silica). For a copy of the Marley clay tiles Safety datasheet, visit marley.co.uk/about/HealthandSafety

APPEARANCE

To avoid the risk of colour patching and bands of different shades, tiles should be randomly selected from at least three separate pallets from the same production batch. Ensure there are sufficient quantities of mixed tiles to complete each roof elevation.

FIXING SPECIFICATION

Tiles should be fixed in accordance with the recommendations of BS 5534. The Marley Technical Advisory Service can provide a fixing specification applicable for every roof design, given the relevant criteria relating to type of roof tile, site location, topography, and building/roof dimensions. Fixing specifications can also be completed online at marley.co.uk/tilefix

DESIGN DETAILS

SETTING OUT

LINCOLN EAVES TO RIDGE

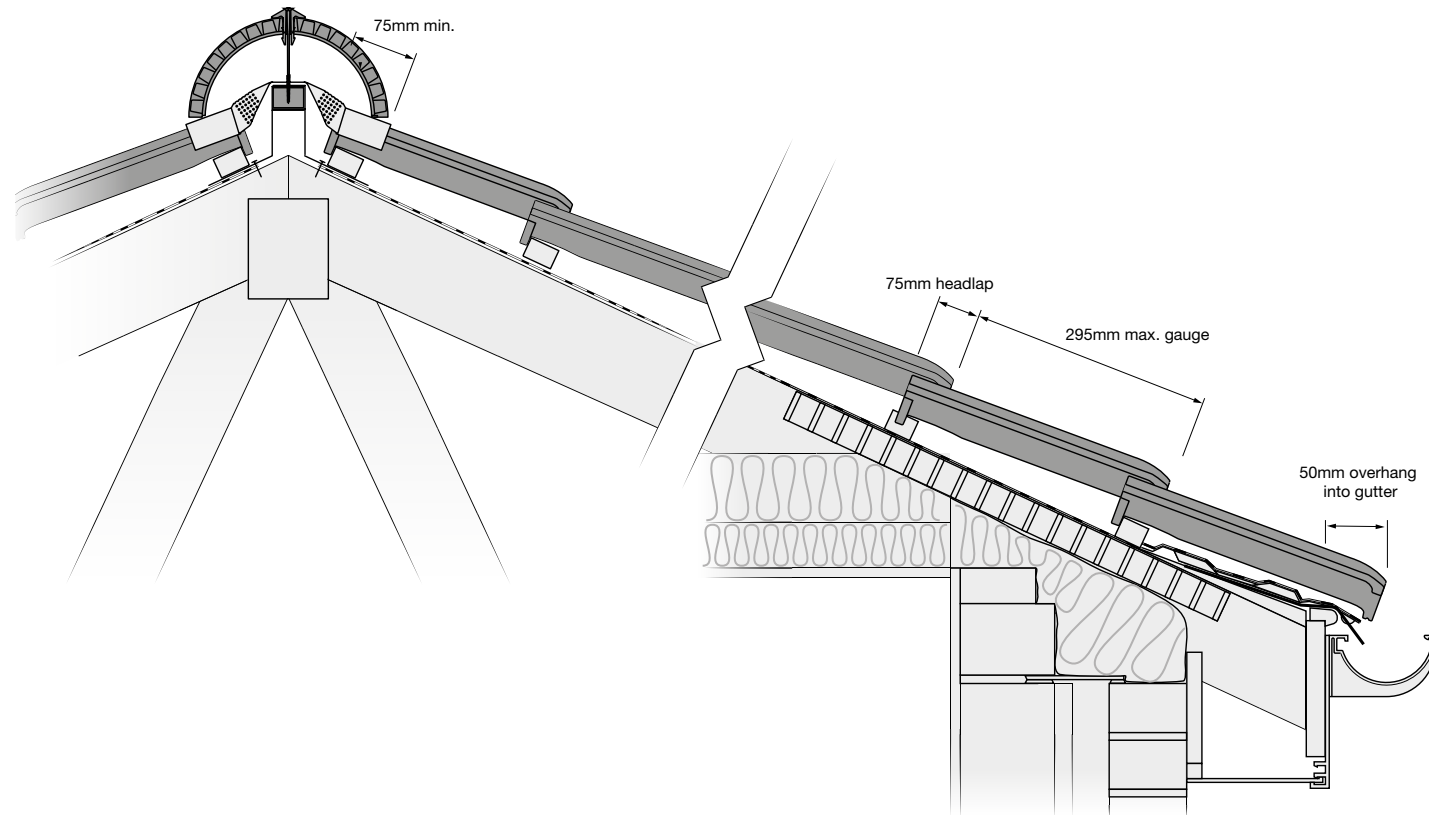

EDEN EAVES TO RIDGE

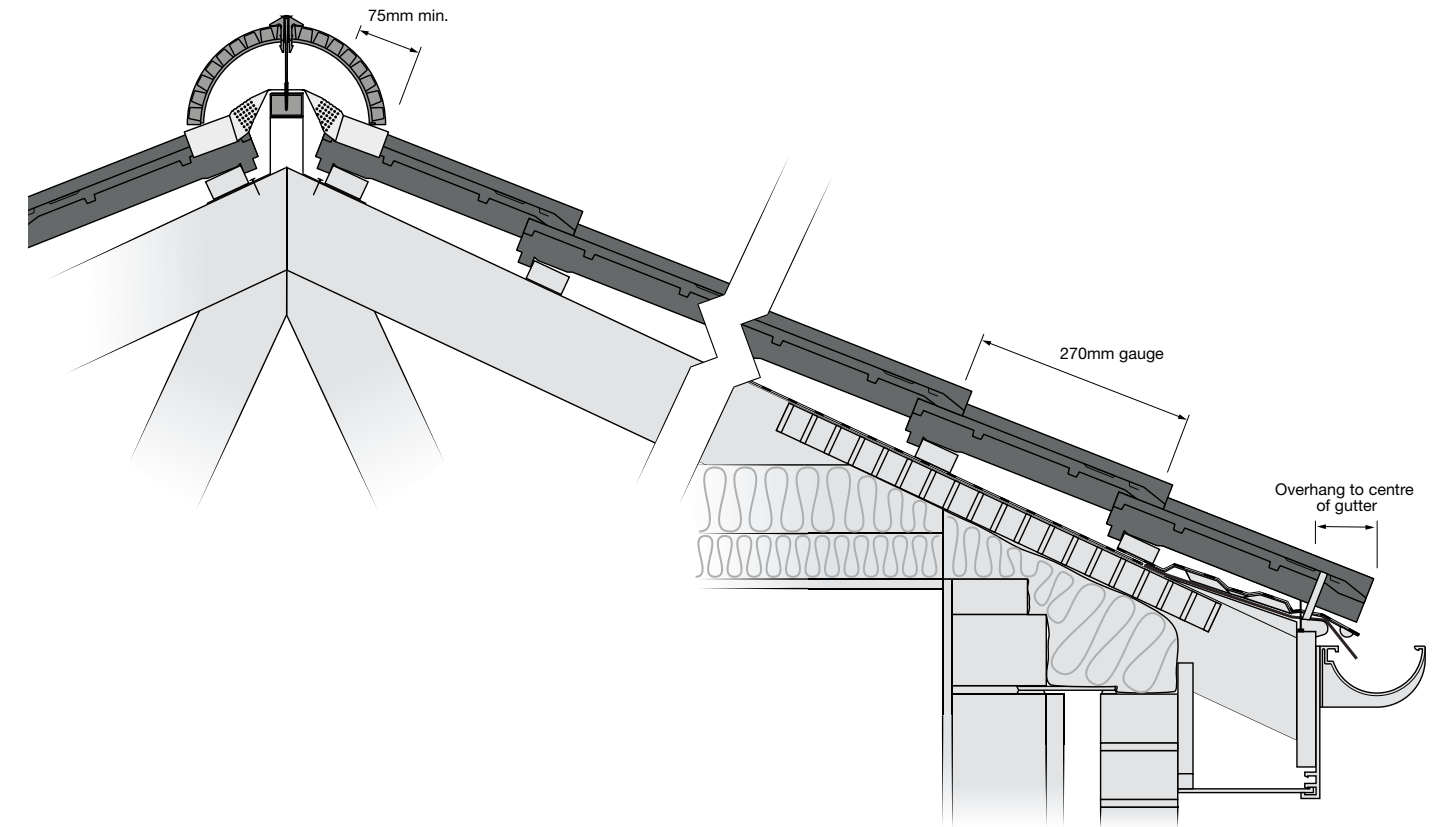

TECHNICAL TOOLKIT

Marley provides a comprehensive technical service and a range of online tools to ensure design performance and compliance to the latest Building Regulations and NHBC Technical Standards. These services include:

- ▲ Fixing specifications marley.co.uk/tilefix
- ▲ NBS clauses marley.co.uk/specrite
- ▲ CAD details marley.co.uk/cad
- ▲ BIM models marley.co.uk/bim

DESIGN DETAILS

EAVES

UNIVERSAL EAVES VENT SYSTEM

- ▲ eaves ventilation to satisfy 10mm or 25mm conditions
- ▲ eaves to ridge ventilation for pitches of 17.5°-70°
- ▲ continuous rafter roll compresses insulation to allow free air passage (use two rolls to compress deep insulation)
- ▲ strip ventilator has discreet ventilation grille and is nailed to fascia or timber fillet
- ▲ suitable with or without soffit board
- ▲ use comb filler strip with deep profiled tiles
- ▲ mechanically fix all tiles at eaves

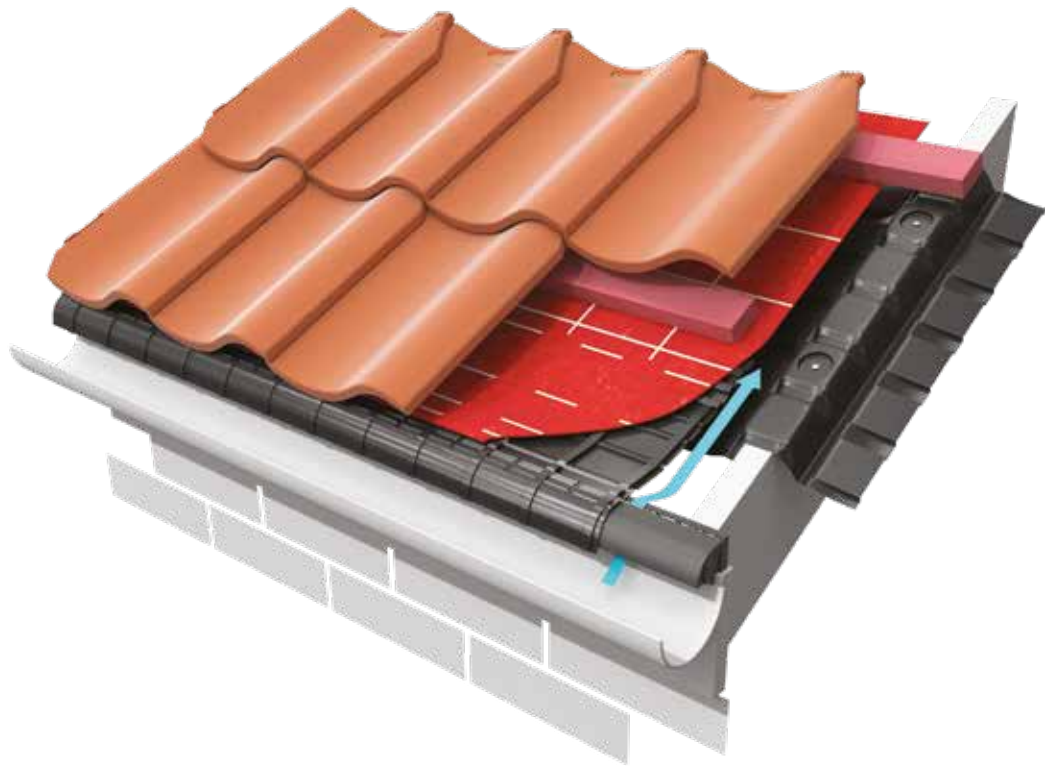
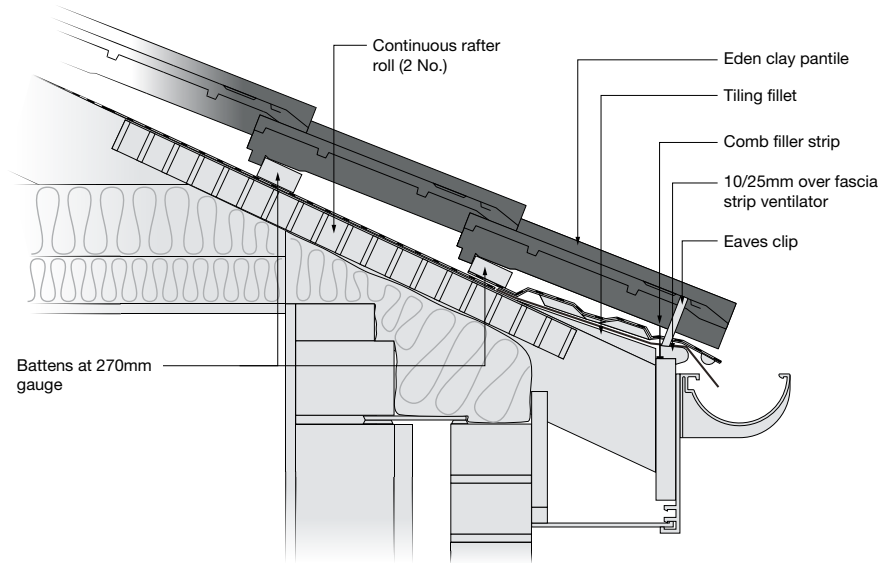

DESIGN DETAILS

VERGES

EDEN BEDDED VERGES

- ▲ ensure undercloak does not tilt towards gable
- ▲ verge overhang should be a maximum of 50mm
- ▲ use Eden left hand verge tile for left hand verges
- ▲ use Eden right hand verge tile for right hand verges
- ▲ twice mechanically fix all verge tiles in accordance with BS 5534



LINCOLN BEDDED VERGES

- ▲ ensure undercloak does not tilt towards gable
- ▲ verge overhang should be a maximum of 50mm
- ▲ use Lincoln left hand verge tile for left hand verges
- ▲ mechanically fix all verge tiles in accordance with BS 5534

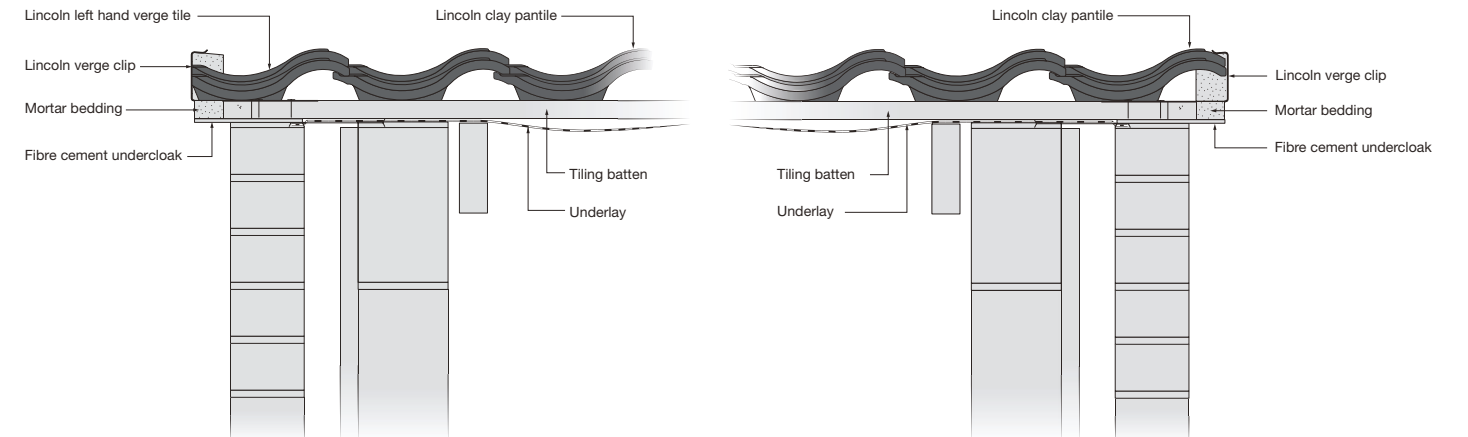
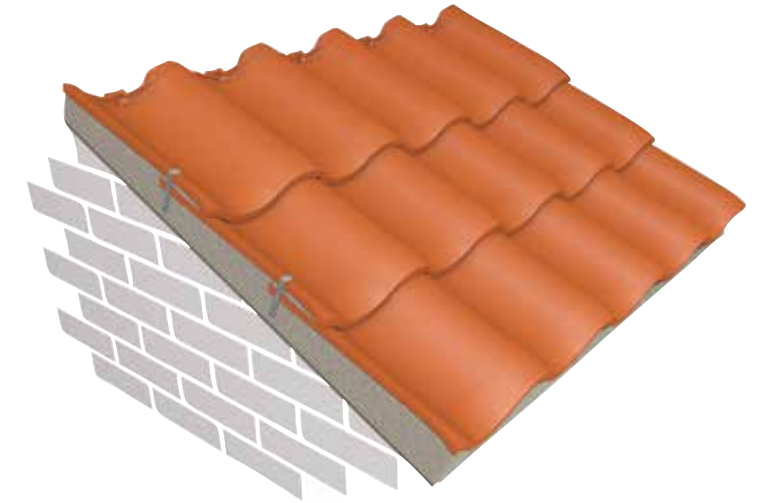

DESIGN DETAILS

HIPS

UNIVERSAL HIPFAST SYSTEM

- ▲ provides additional ventilation to the roof void when a 5mm gap in the underlay is used in conjunction with either eaves or ridge ventilated systems or ventilation tiles
- ▲ use one or two thicknesses of 50mm x 25mm batten to fit batten brackets
- ▲ use hip end hip tile at eaves
- ▲ mechanically fix each hip tile via hip unions and clamps
- ▲ complete hip at ridge with soaker flashing

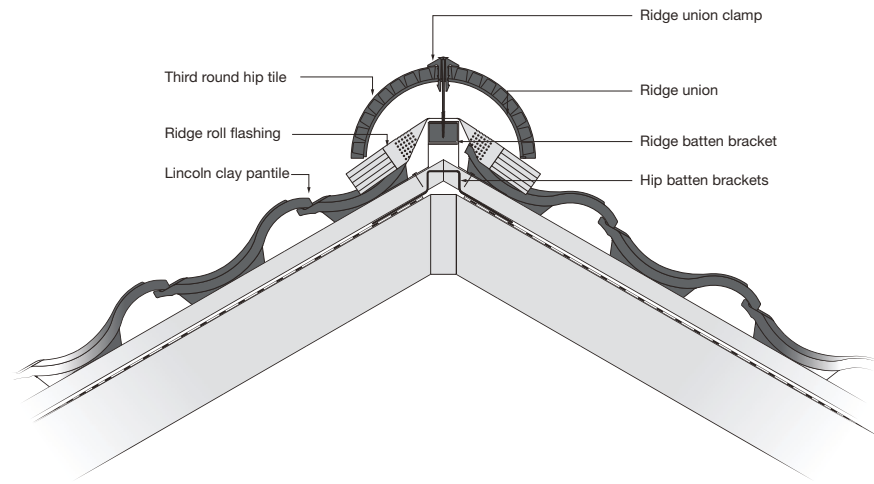

MORTAR BEDDED HIPS

- ▲ maximum rafter pitch 45°
- ▲ fix hip units to hip tree using ridge clamp and 100mm stainless steel screw
- ▲ complete hip at ridge apex with three way mitre

DESIGN DETAILS

VALLEYS

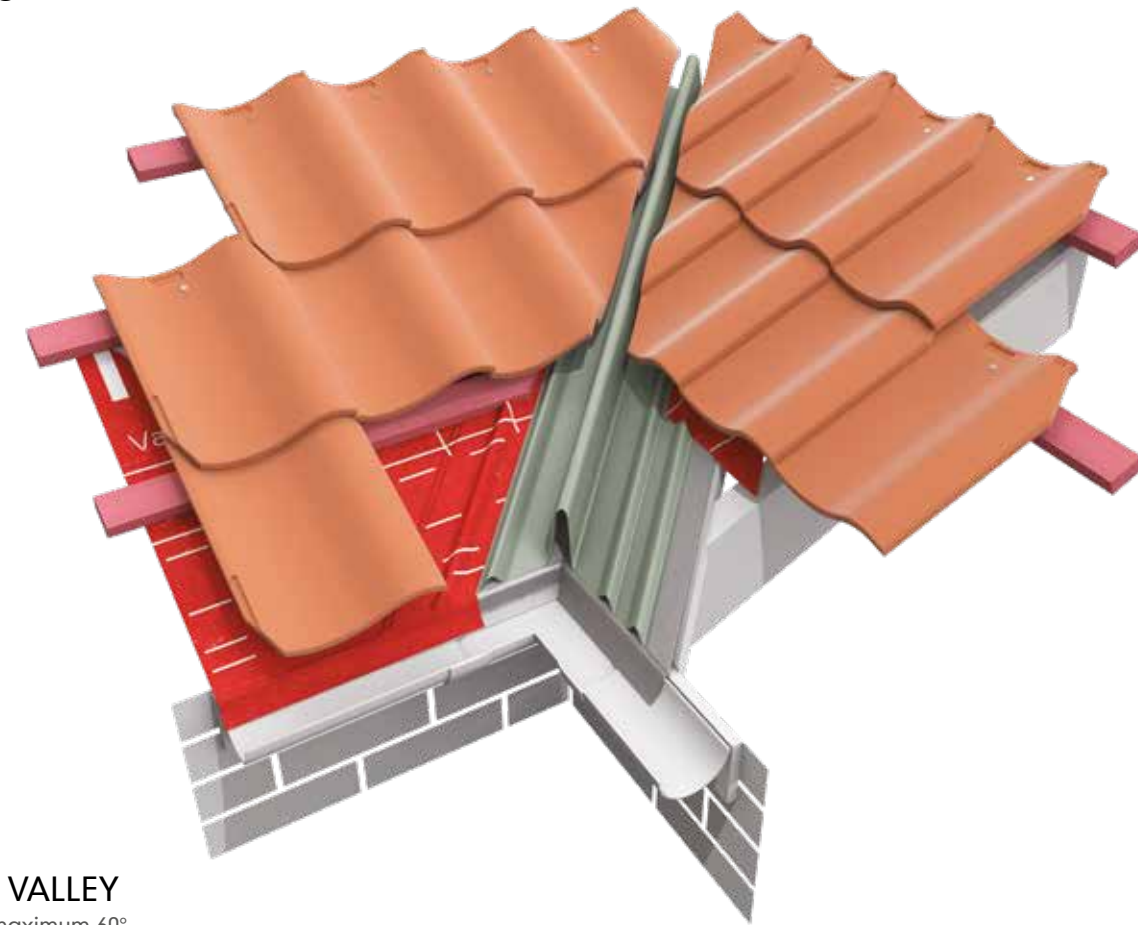

UNIVERSAL GRP DRY VALLEY

- ▲ minimum rafter pitch 17.5°, maximum 60°
- ▲ maximum valley length 8m
- ▲ suitable for all plan angles and where the pitch either side of the valley varies by a maximum of 20°
- ▲ provide continuous support for valley trough using 18-20mm ply boards on timber supports or overlaid on the rafters
- ▲ tightly butt tiles or slates to central upstand of valley units to prevent ingress of birds or vermin
- ▲ provide metal apron at foot of valley and dress into gutter at eaves. For rafter pitches below 25° cut fascia board to maintain valley pitch
- ▲ nail or clip adjacent tiles to the valley
- ▲ complete top of valley with a lead saddle

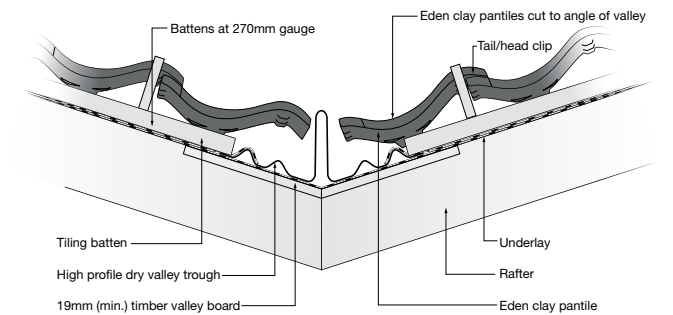

TECHNICAL TOOLKIT

Marley provides a comprehensive technical service and a range of online tools to ensure design performance and compliance to the latest Building Regulations and NHBC Technical Standards. These services include:

- ▲ Fixing specifications marley.co.uk/tilefix
- ▲ NBS clauses marley.co.uk/specrite
- ▲ CAD details marley.co.uk/cad
- ▲ BIM models marley.co.uk/bim

DESIGN DETAILS RIDGES

UNIVERSAL RIDGEFAST SYSTEM

- ▲ provides 5,000mm²/m free vent area at ridge apex
- ▲ ensure gap is provided in roof underlay to vent roof void
- ▲ use one or two thicknesses of 50mm x 25mm batten to fit batten brackets
- ▲ mechanically fix all top course tiles
- ▲ use ridge end tile

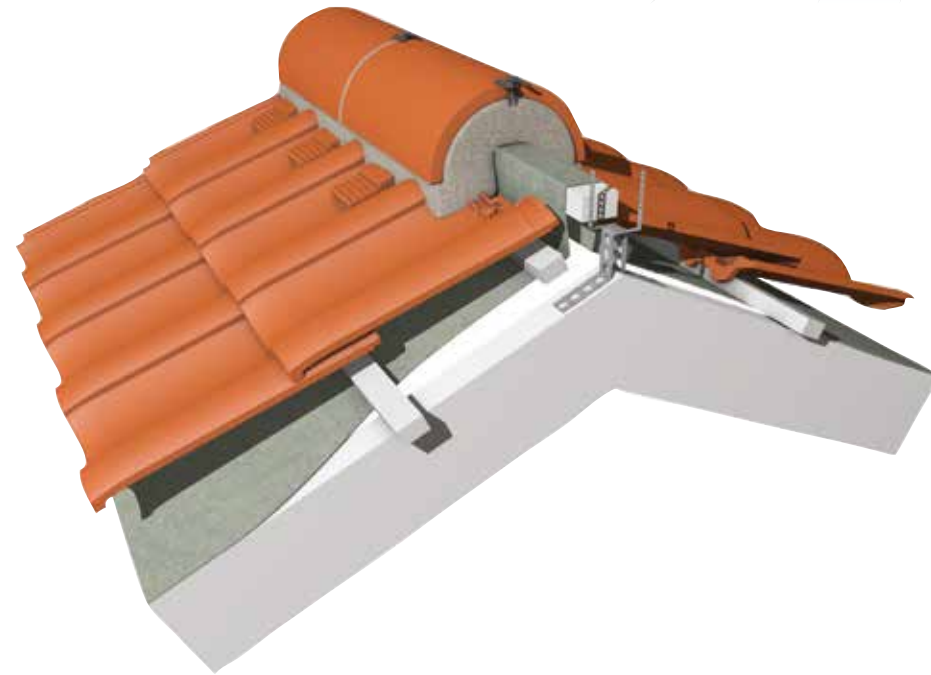
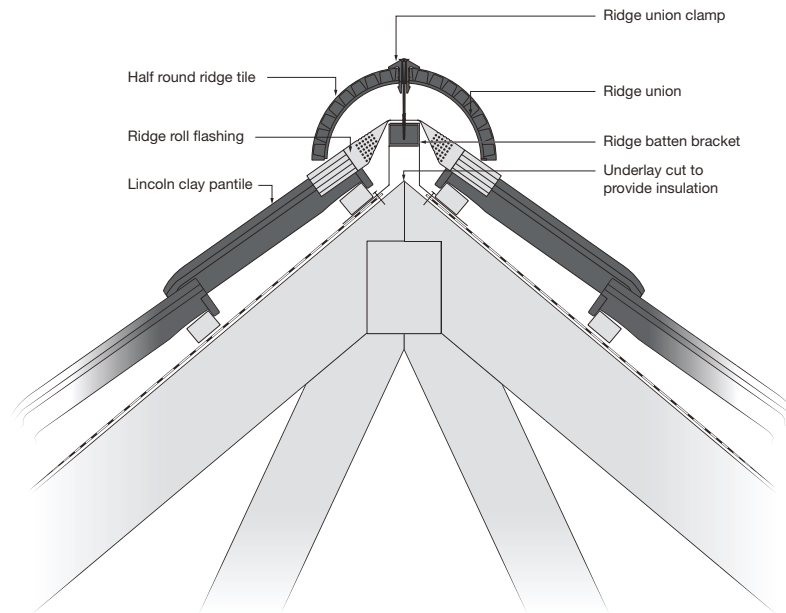

MORTAR BEDDED RIDGES

- ▲ security ridge fixing kits are available for Lincoln clay ridges
- ▲ maximum rafter pitch 50°
- ▲ fix ridge units to ridge batten using ridge clamp and 100mm stainless steel screw
- ▲ mechanically fixes ridge tile in line with BS 5534 fixing guidelines

DESIGN DETAILS ABUTMENT AND TILE VENT

ABUTMENT

- ▲ maximum rafter pitch 45° (55° using steep pitch batten section)
- ▲ provides 5,000mm²/lin.m ventilation
- ▲ ensure air passage from roof void is not obstructed
- ▲ mechanically fix all top course tiles
- ▲ use minimum 1.5m length of lead flashing with 150mm side laps

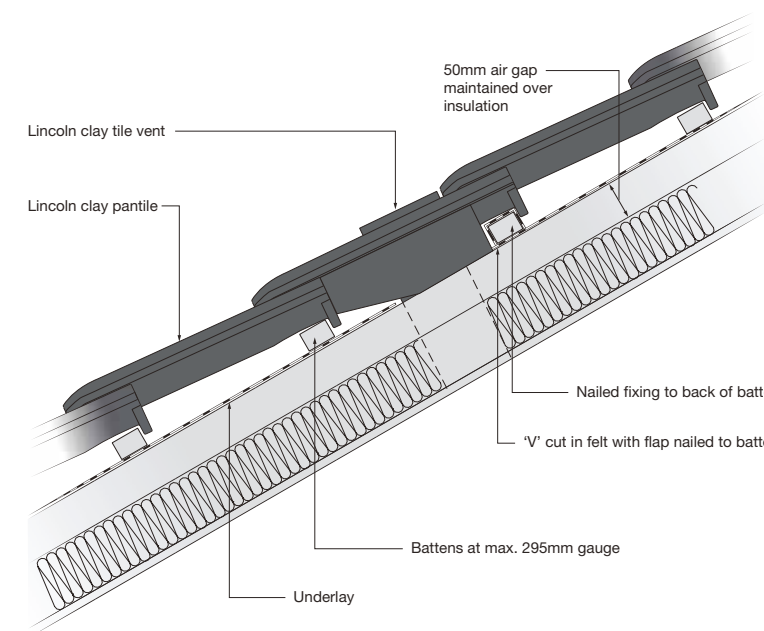
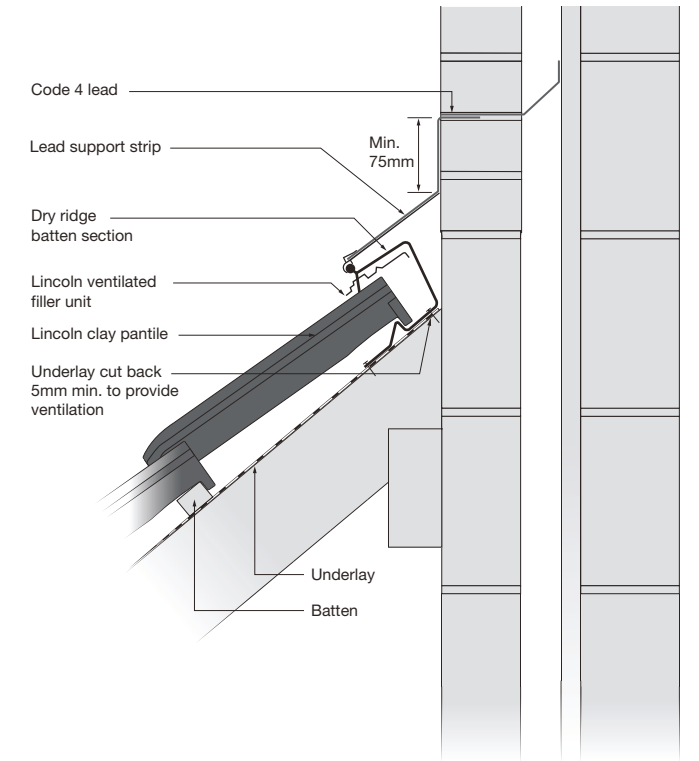

LINCOLN CLAY TILE VENT

- ▲ locate clear of rafters
- ▲ use spigot-soaker tray to weather the offset hole in underlay
- ▲ locate at 1.3-1.5m centres for 5,000mm²/lin.m ventilation and 565-765mm centres for 10,000mm²/lin.m ventilation

TECHNICAL TOOLKIT

Marley provides a comprehensive technical service and a range of online tools to ensure design performance and compliance to the latest Building Regulations and NHBC Technical Standards. These services include:

- ▲ Fixing specifications marley.co.uk/tilefix
- ▲ NBS clauses marley.co.uk/specrite
- ▲ CAD details marley.co.uk/cad
- ▲ BIM models marley.co.uk/bim



Here to help

Getting our knowledge to you and your project smoothly and efficiently

▲ CUSTOMER SERVICES

Marley is committed to providing outstanding customer care and is staffed by experienced personnel: **Tel 01283 722588** or **e-mail info@marley.co.uk**

To find your nearest stockist, please visit: marley.co.uk/stockists

▲ TECHNICAL ADVISORY SERVICE

Specifiers require prompt, knowledgeable and detailed responses to a vast range of enquiries covering everything from the embodied energy of a typical roof tile, to the different ventilation options available.

Our Technical Advisory Service is staffed by a qualified team with specialist knowledge not only of all Marley products, but also crucially, how those systems integrate with other roofing components and comply with Building Regulations, Health and Safety, environmental and other critical roofing criteria.

Tel 01283 722588, **E-mail info@marley.co.uk** or visit marley.co.uk/resources

▲ ACTING RESPONSIBLY AND DELIVERING SUSTAINABLE QUALITY

BES 6001

Demonstrating our commitment to sustainable building, all our roofing products are certified under the BES 6001 standard for responsible sourcing and therefore contribute to extra credits under BREEAM and The Code for Sustainable Homes.

QUALITY STANDARD

All our factories in the UK are ISO 9001, 14001 and ISO OHSAS 18001 accredited. They achieve the highest standards in quality, health & safety and the environment.

CE MARKING

All of our products covered by EN Standard carry an appropriate CE Mark. This means that our products meet the required safety standards and have a guaranteed level of quality.

▲ TOOLS

Tools and assets that make design and specification as straightforward as possible.

SPECRITE

Produce instant NBS clauses that meet the recommendations of British Standards and Codes of Practice: marley.co.uk/specrite

TILEFIX

Tool to create fixing specifications based on the geographical location and building dimensions of specific roofing projects: marley.co.uk/tilefix

ROOFING ESTIMATOR

Create a complete bill of materials for your project based on a wide range of building and roof types: marley.co.uk/estimator

BIM

BIM Space is a set of free-to-download Building Information Modelling (BIM) objects that provide a standard range of build ups for all of our products: marley.co.uk/bim

CAD DETAILS

Access to over 2,000 CAD drawings illustrating how specific tile and slate details can be formed: marley.co.uk/cad

ROOF SYSTEM SELECTOR

Easy-to-use and comprehensive system finder delivering results from choice of pitch, material or tile type: marley.co.uk/productselector

▲ RESOURCES AND TRAINING

SAMPLES

Samples of clay and concrete interlocking and plain tiles are available on request. **Call 01283 722588** or visit marley.co.uk/samples

FIXING INSTRUCTIONS AND LITERATURE

Comprehensive sitework, fixing and installation literature and videos: marley.co.uk/resources
All current product and technical literature can be downloaded: marley.co.uk/downloads

CPDS

A range of Continuous Professional Development roofing seminars accredited by the RIBA CPD Certification Service. For more information or to make a booking: marley.co.uk/cpd

TRAINING

Theoretical, practical, engaging and informative training available at three locations nationwide. marley.co.uk/training

This publication is based on the latest data available at the time of printing. Due to product changes, improvements and other factors, the Company reserves the right to change or withdraw information contained herein without prior notice. For specific applications users should refer to the Technical Advisory Service and relevant Standards and Codes of Practice for guidance. The photography shown in the document should not necessarily be taken as recommendations of good practice. The printing process restricts the exact representation of colours. For true colour reference, please request product samples.



Tell me more

Call 01283 722588

Email info@marley.co.uk

Or visit marley.co.uk

Marley, Lichfield Road, Branston, Burton upon Trent, DE14 3HD

