

In preparing the designs illustrated by this drawing we have fulfilled our duties in the role of Designer as defined in the Construction Design and Management Regulations 2015. We have undertaken a full Hazard Identification and Risk Analysis and have designed out any special risks associated with the work, so that as far as possible there are no residual risks.

NOTE: Residual risks are defined as those risks arising from identified hazards which cannot be designed-out, and which a competent and experienced building contractor is unlikely to encounter during normal construction activities. Ordinary risks arising from normal construction operations have not been included.

Where hazards have been identified, the risks from which it has not been possible to eliminate during the design process, these are indicated on the drawing. It will be the responsibility of the Principal Contractor to develop Safe Systems of Work and/or Method Statements to minimise any risks associated with such hazards.

NOTES

- This drawing has been prepared using a Topographical Survey Drawing supplied by the client in AutoCAD format.
- This drawing is to be read in conjunction with all relevant Engineers' and Architects' drawings and specifications.
- All dimensions are in millimetres unless noted otherwise. All levels are in metres.
- The contractor is responsible for setting out and for checking dimensions.
- In accordance with The Construction (Design and Management) Regulations 2015 (CDM 2015) the Principle Designer and Contractor are to:
 - Notify HSE of works.
 - Comply with the requirements of Health and Safety Plan (if applicable)
 - Provide risk assessments and method statements for all potential hazards relevant to this project.
- The main contractor shall be responsible for the setting out and accuracy of all dimensions. The contractor shall be satisfied that the information given is correct and any discrepancies should be noted to the Engineer immediately.
- Contractor to ensure that the existing sewers remain in service until the diversion works are completed.
- The Contractor is responsible for specifying product and codes and ordering of drainage materials.
- Contractor to ensure that new sewers are laid and installed in like to like basis.
- New adoptable pipework to be vitrified clay type and to be constructed to the following specifications. Systems that are resistant to a jetting pressure of 4000psi. Systems that minimise the number of joints in the system, by using 3metre pipe length. Systems that do not have lip seal joints, hence preventing root ingress.
- All non-uPVC (adoptable) pipe connection to manholes shall be provided with a 'rocker pipe' of 600mm effective length in accordance with CI E6.6 of 'Sewers for Adoption'.
- Precast concrete manhole units shall comply with the relevant provisions of BS EN 1917 and BS 5911-3.
- The diameter of the pipes to be diverted are 300mm for storm and 150mm for foul. The new pipes are to be of 300mm and 150mm for foul diameter respectively. Any abandoned pipes or manholes are to be grubbed out or sealed up.
- Cover grades are in accordance with BS497 Pt 1
Cover Grades : D400 - carriageways.
B125 - carriageways for slow traffic.
A15 - inaccessible to vehicles
- All drainage pipes within development site to be 100mm dia unless shown otherwise.
- All uPVC drainage to be installed to BS5955 Pt6 and in strict accordance with the manufacturers instructions.
- All uPVC drainage products to conform to BS EN1401 & Kite mark certified in accordance with specification.
- All adoptable drainage and associated works to comply with the latest Part E - Civil Engineering Specification of 'Sewer for Adoption'.
- DO NOT SCALE. If discrepancy or query arises on dimensions consult Engineer.

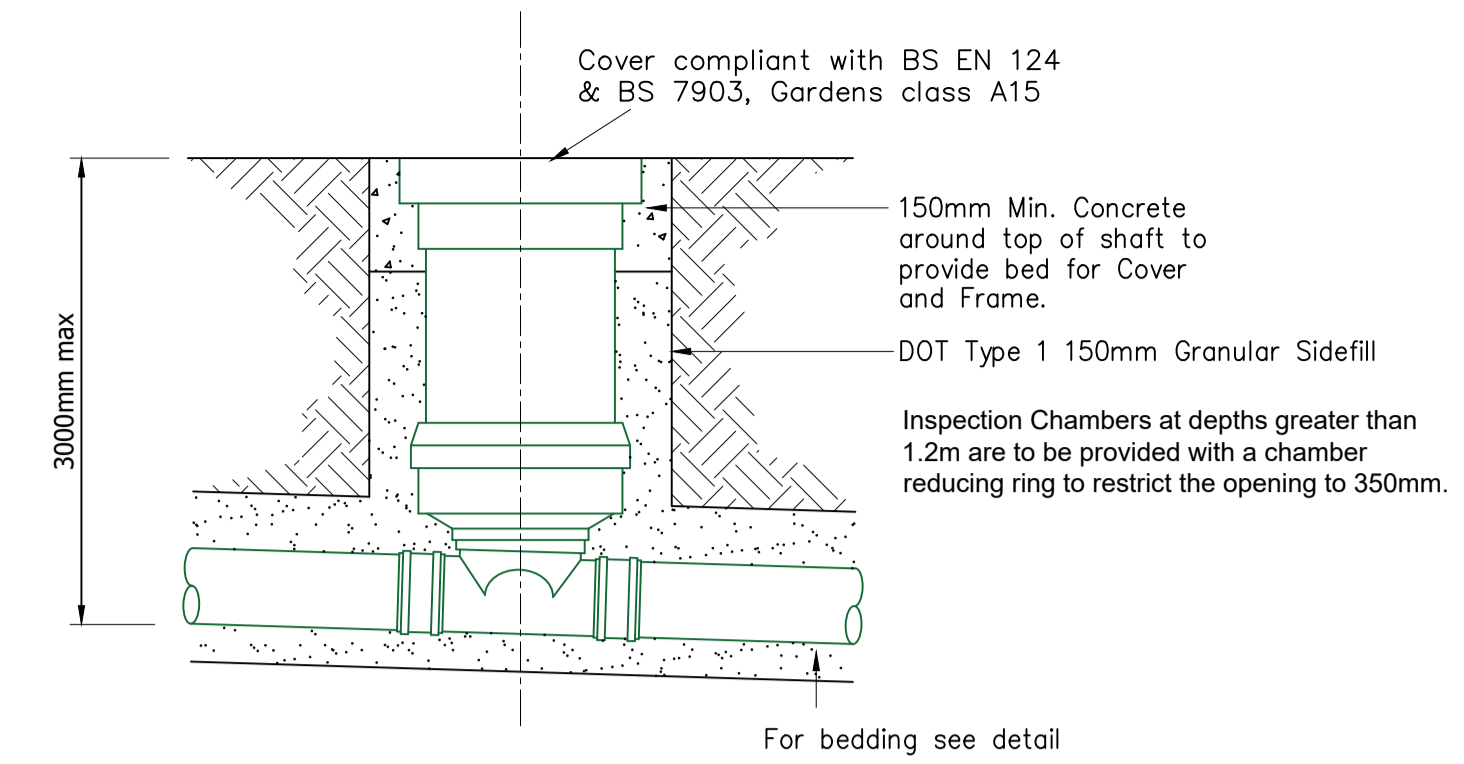

**450mmØ INSPECTION CHAMBER
GRADE 'A' NON-LOAD BEARING INSTALLATION**
1:10

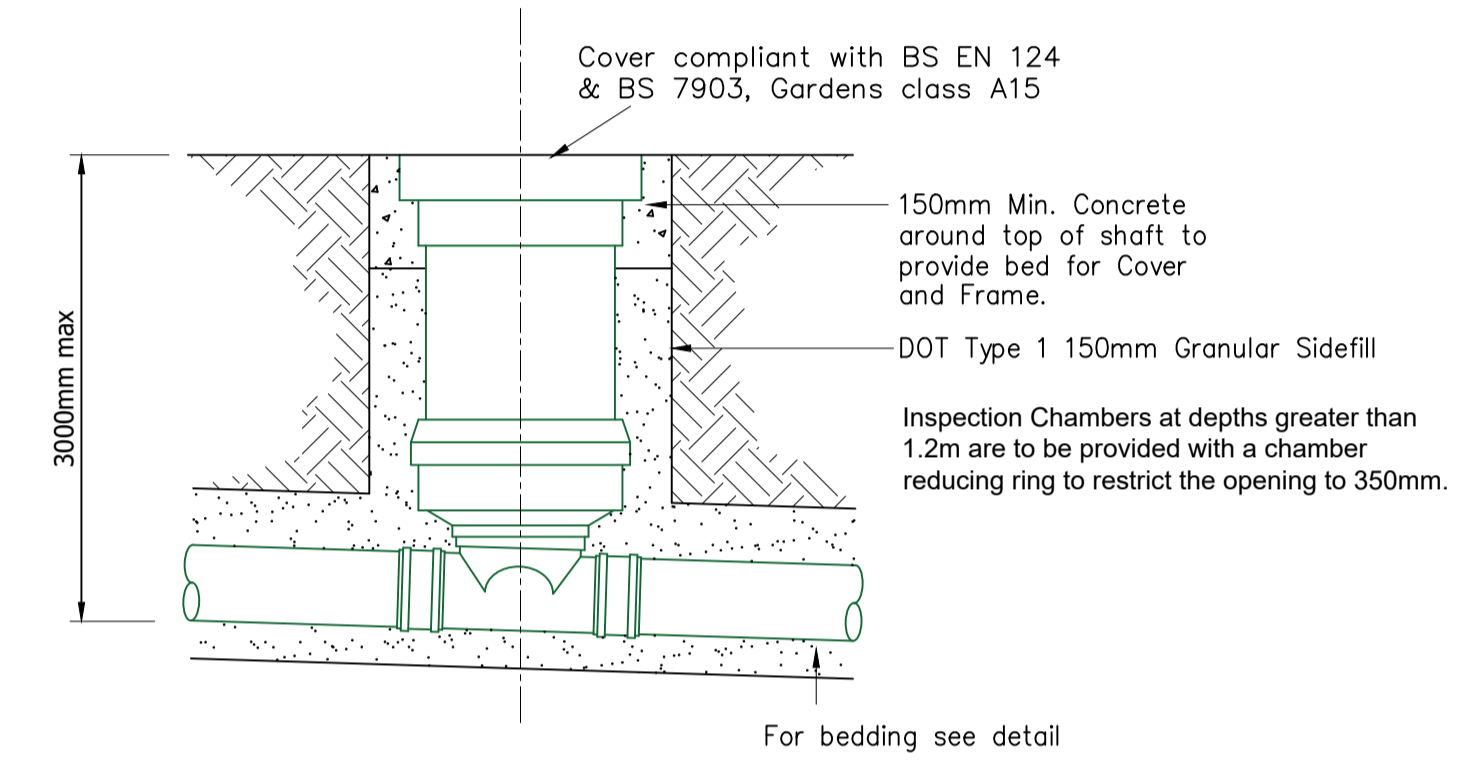

**450mmØ INSPECTION CHAMBER
GRADE 'A' NON-LOAD BEARING INSTALLATION**
1:10

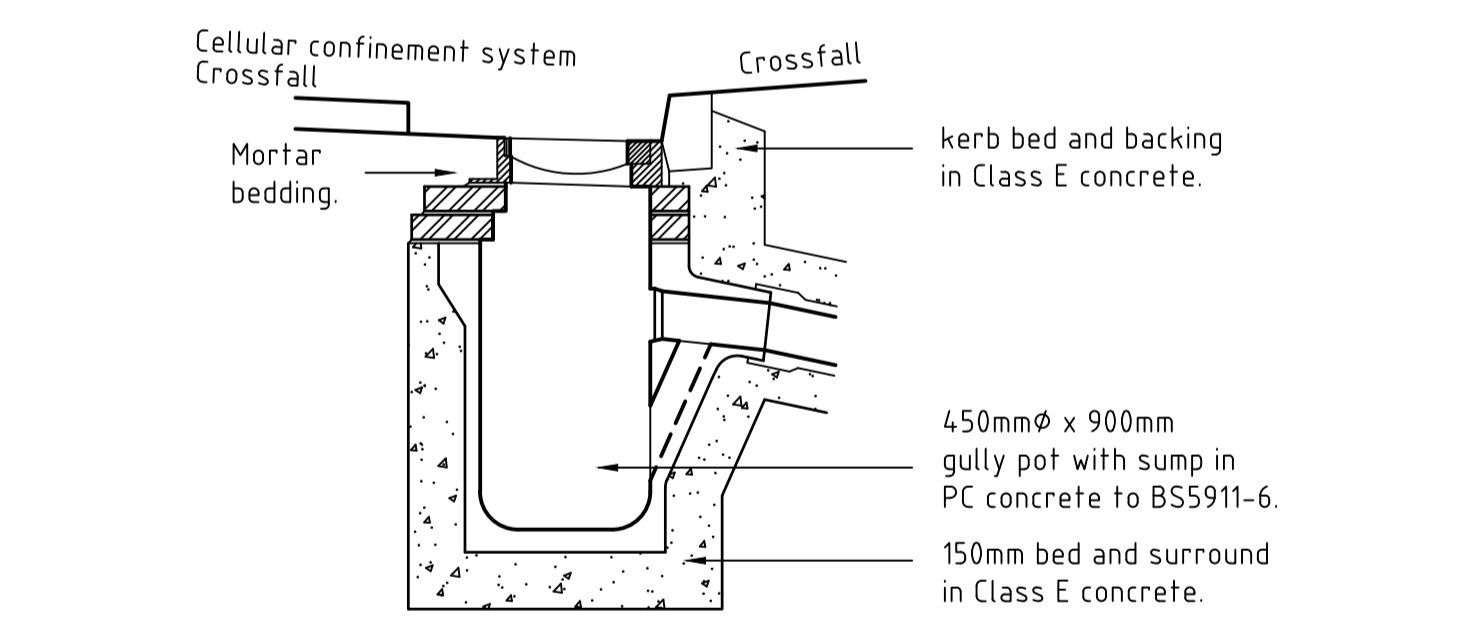

CONCRETE GULLY DETAIL
Scale 1:20

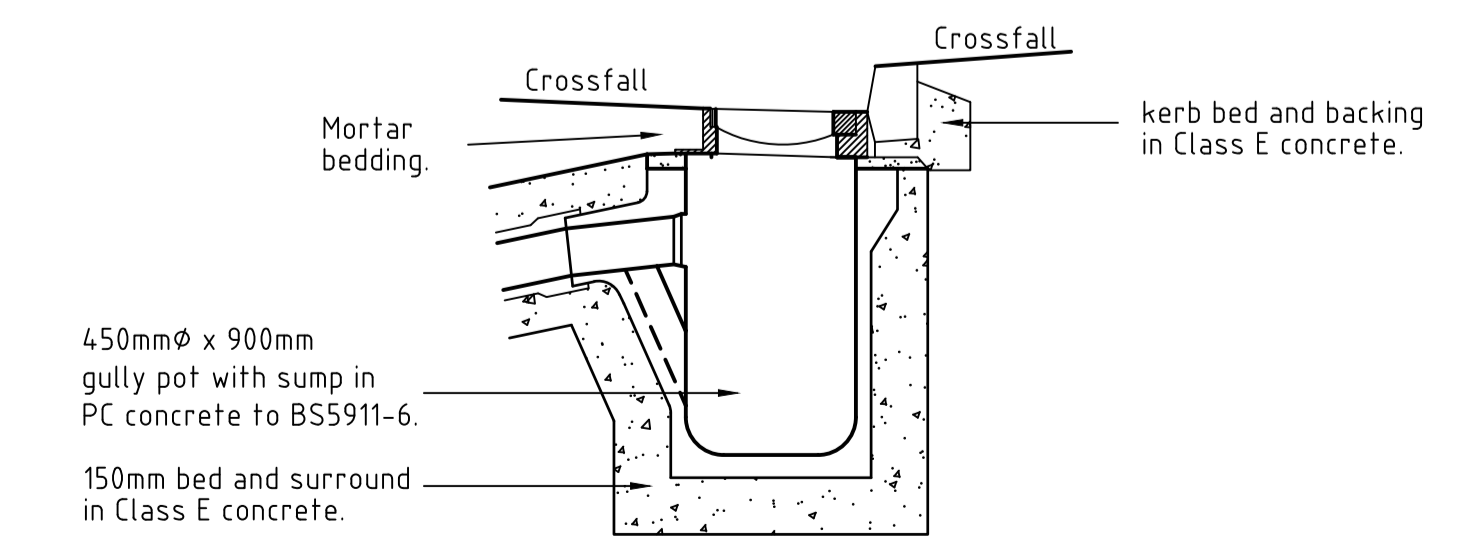

ACCESS ROAD CONCRETE GULLY DETAIL
Scale 1:20

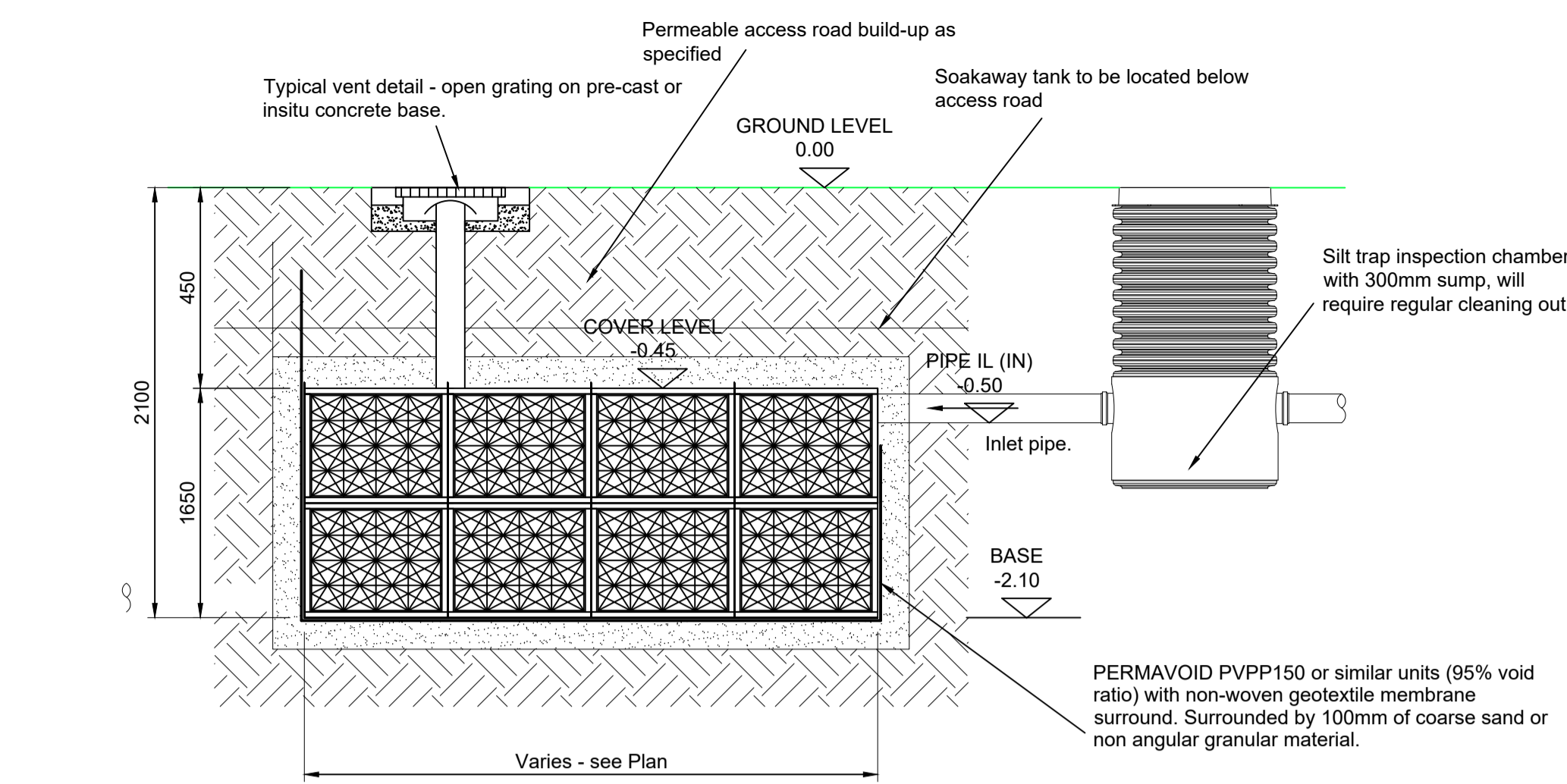

**TYPICAL SECTION
STORM WATER SOAKAWAY DETAIL UNDER ACCESS ROAD**
1:20

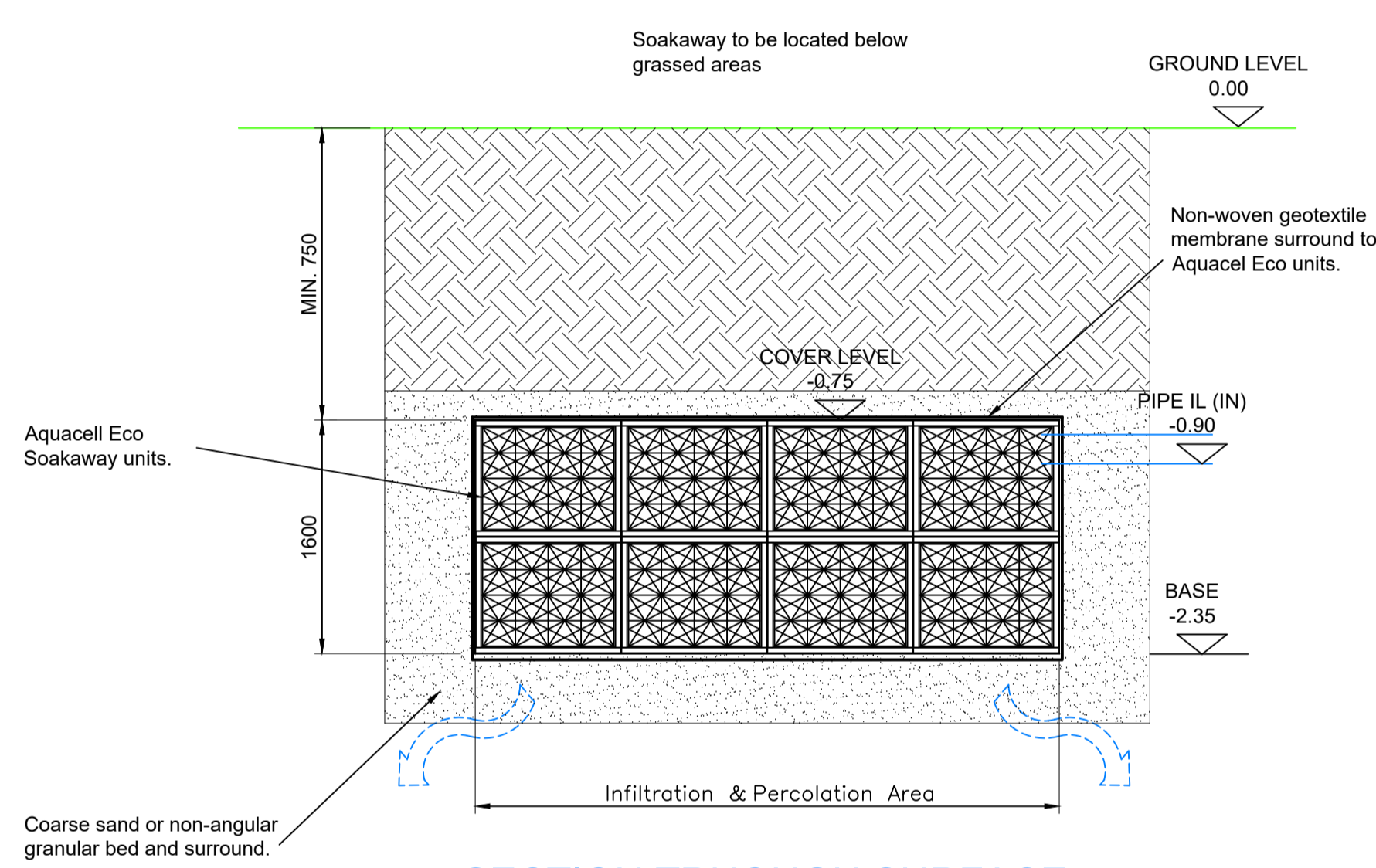

**SECTION THROUGH SURFACE
WATER SOAKAWAY DETAIL WITHIN GARDENS**
1:20

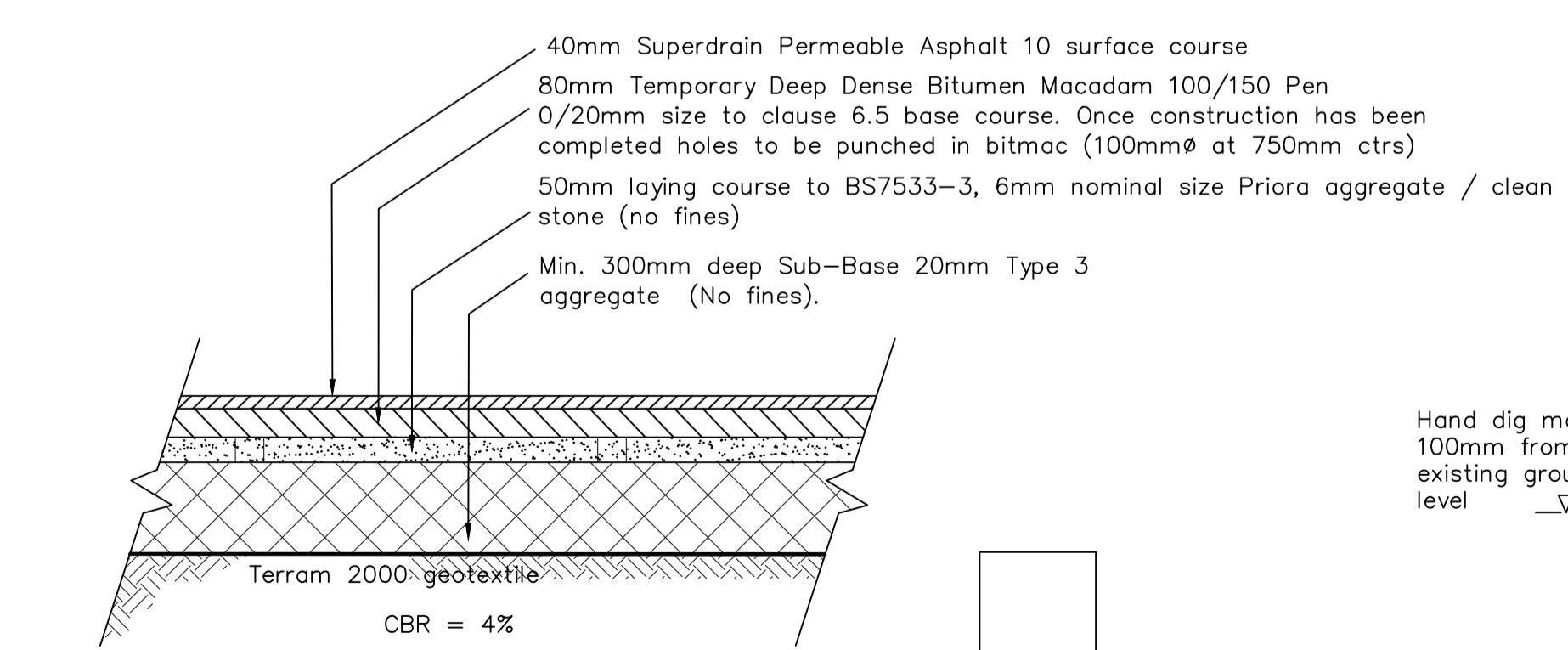

DETAIL 1 - NEW ACCESS ROAD - TYPICAL SECTION
SCALE 1:20

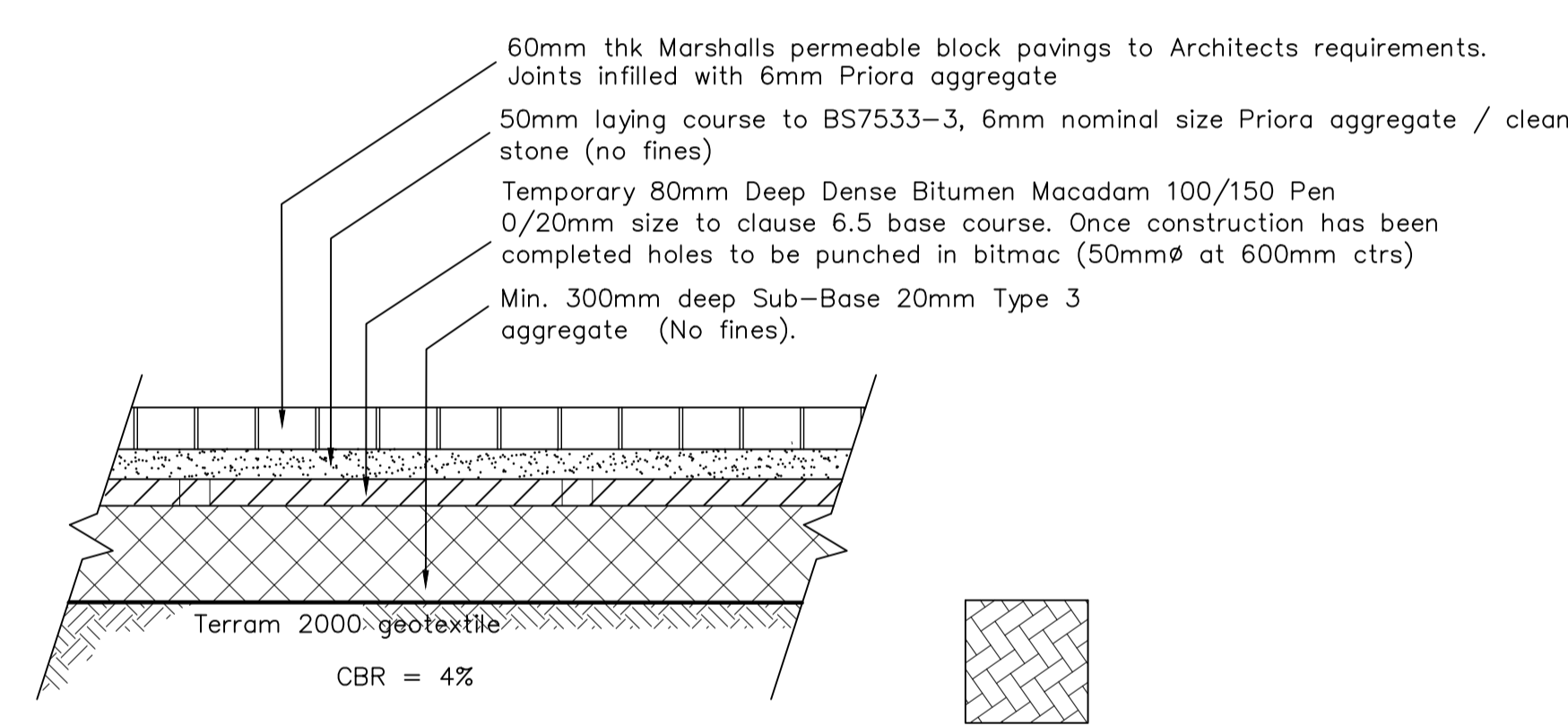

**DETAIL 2 - DRIVEWAY & PARKING AREAS
CONSTRUCTION - TYPICAL SECTION**
SCALE 1:20

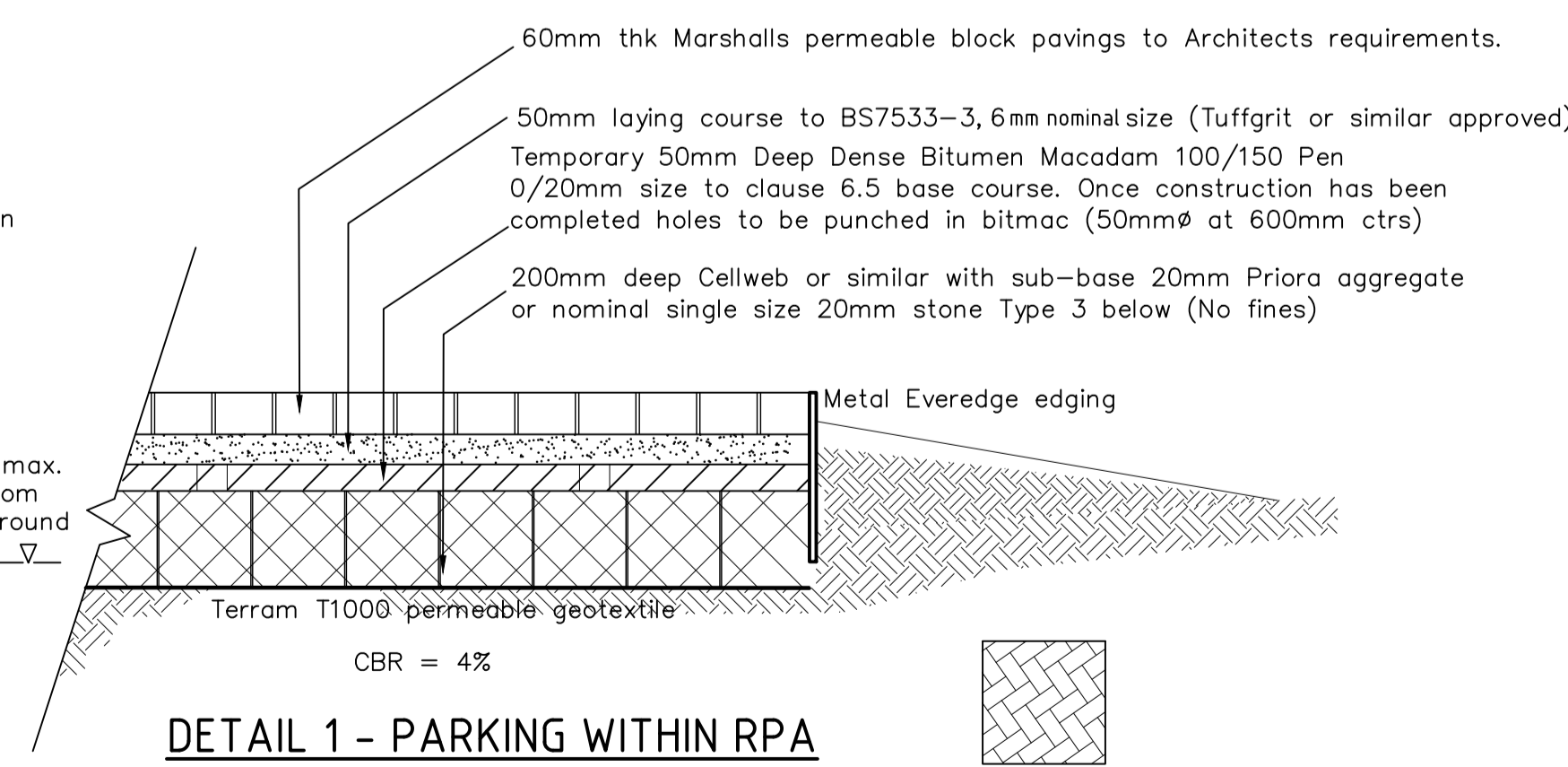

**DETAIL 1 - PARKING WITHIN RPA
CONSTRUCTION - TYPICAL SECTION**
SCALE 1:20

Date	By	Revision	QA'D	Chk'd	Ref

Status: **PRELIMINARY**

Cowan Consultancy
STRUCTURAL CIVIL AND BUILDING CONSULTANTS

Also at:
Landguard Manor
Landguard Manor Road
Shanklin
Isle of Wight
PO37 7JB

3 Turnberry House
4400 Parkway
Whiteley
Fareham
Hampshire
PO15 7FJ

Tel: 01489 577488
Fax: 01489 579873
consultants@cowanconsult.co.uk
www.cowanconsult.co.uk

Client: **IMPERIAL HOMES SOUTH LTD.**

Project: **DEVELOPMENT AT BITTERNE PARISH CHURCH
WHITES LANE, BITTERNE, SOUTHAMPTON**

Title: **INFRASTRUCTURE
STORM & FOUL WATER DRAINAGE
STANDARD DETAILS (1/2)**

Date	Scale	AS SHOWN	© A1	Drg. No.
OCT 2023	AS SHOWN	© A1		456146/204P

In preparing the designs illustrated by this drawing we have fulfilled our duties in the role of Designer as defined in the Construction Design and Management Regulations 2015. We have undertaken a full Hazard Identification and Risk Analysis and have designed out any special risks associated with the work, so that as far as possible there are no residual risks.

NOTE: Residual risks are defined as those risks arising from identified hazards which cannot be designed-out, and which a competent and experienced building contractor is unlikely to encounter during normal construction activities. Ordinary risks arising from normal construction operations have not been included.

Where hazards have been identified, the risks from which it has not been possible to eliminate during the design process, these are indicated on the drawing. It will be the responsibility of the Principal Contractor to develop Safe Systems of Work and/or Method Statements to minimise any risks associated with such hazards.

NOTES

- This drawing has been prepared using a Topographical Survey Drawing supplied by the client in AutoCAD format.
- This drawing is to be read in conjunction with all relevant Engineers' and Architects' drawings and specifications.
- All dimensions are in millimetres unless noted otherwise. All levels are in metres.
- The contractor is responsible for setting out and for checking dimensions.
- In accordance with The Construction (Design and Management) Regulations 2015 (CDM 2015) the Principle Designer and Contractor are to:
 - Notify HSE of works.
 - Comply with the requirements of Health and Safety Plan (if applicable)
 - Provide risk assessments and method statements for all potential hazards relevant to this project.
- The main contractor shall be responsible for the setting out and accuracy of all dimensions. The contractor shall be satisfied that the information given is correct and any discrepancies should be noted to the Engineer immediately.
- Contractor to ensure that the existing sewers remain in service until the diversion works are completed.
- The Contractor is responsible for specifying product and codes and ordering of drainage materials.
- Contractor to ensure that new sewers are laid and installed in like to like basis.
- New adoptable pipework to be vitrified clay type and to be constructed to the following specifications. Systems that are resistant to a jetting pressure of 4000psi. Systems that minimise the number of joints in the system, by using 3metre pipe length. Systems that do not have lip seal joints, hence preventing root ingress.
- All non-uPVC (adoptable) pipe connection to manholes shall be provided with a 'rocker pipe' of 600mm effective length in accordance with CI E6.6 of 'Sewers for Adoption'.
- Precast concrete manhole units shall comply with the relevant provisions of BS EN 1917 and BS 5911-3.
- The diameter of the pipes to be diverted are 300mm for storm and 150mm for foul. The new pipes are to be of 300mm and 150mm for foul diameter respectively. Any abandoned pipes or manholes are to be grubbed out or sealed up.
- Cover grades are in accordance with BS497 Pt 1
 Cover Grades : D400 - carriageways.
 B125 - carriageways for slow traffic.
 A15 - inaccessible to vehicles
- All drainage pipes within development site to be 100mm dia unless shown otherwise.
- All uPVC drainage to be installed to BS5955 Pt6 and in strict accordance with the manufacturers instructions.
- All uPVC drainage products to conform to BS EN1401 & Kite mark certified in accordance with specification.
- All adoptable drainage and associated works to comply with the latest Part E - Civil Engineering Specification of 'Sewer for Adoption'.
- DO NOT SCALE. If discrepancy or query arises on dimensions consult Engineer.

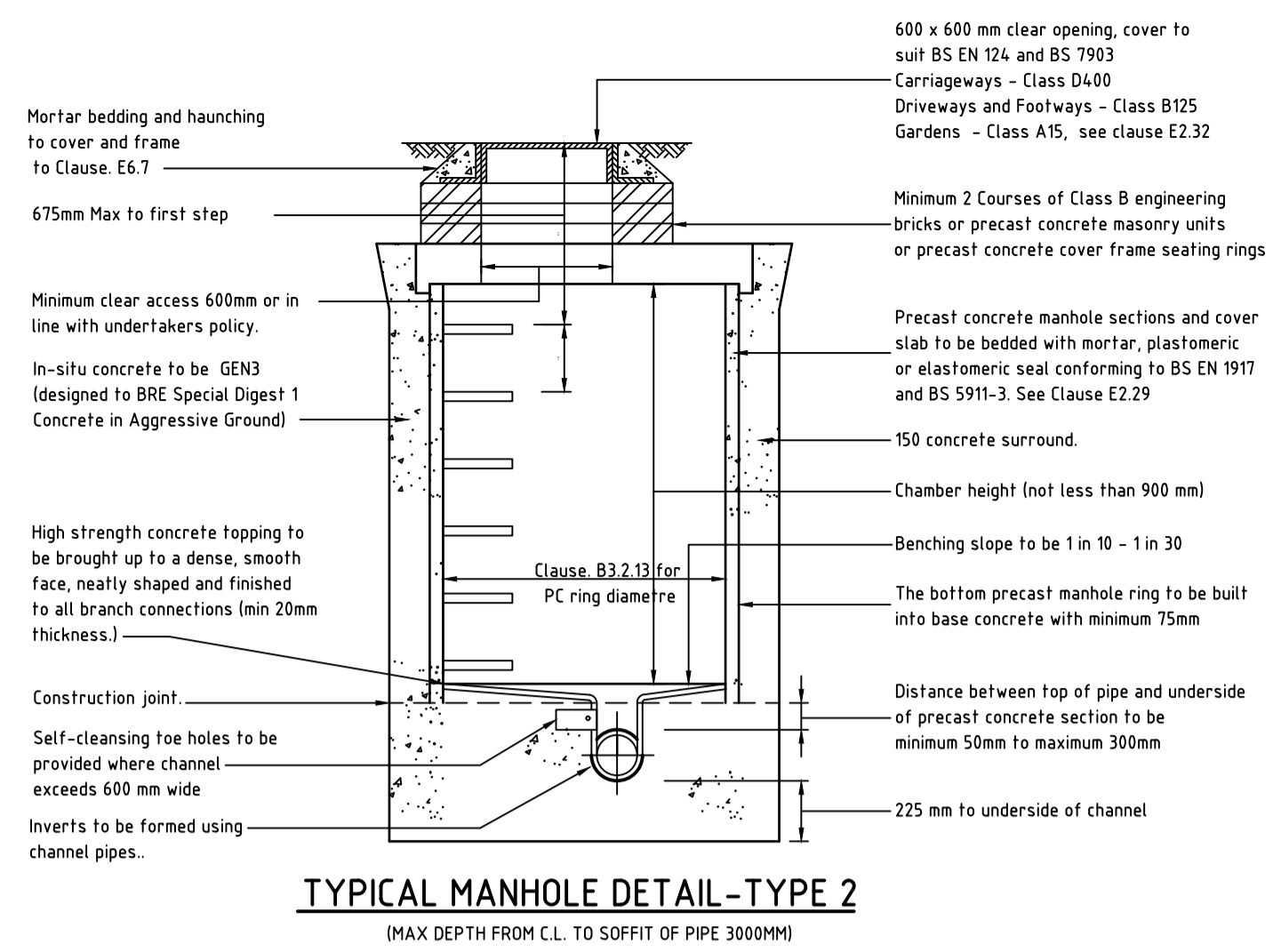

TYPICAL MANHOLE DETAIL-TYPE 2
(MAX DEPTH FROM C.L. TO SOFFIT OF PIPE 3000MM)

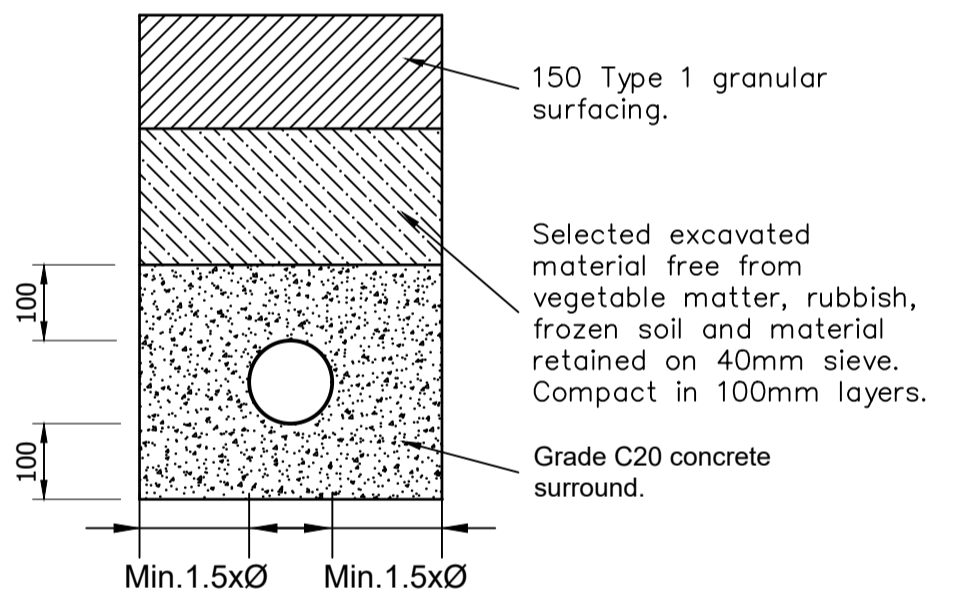
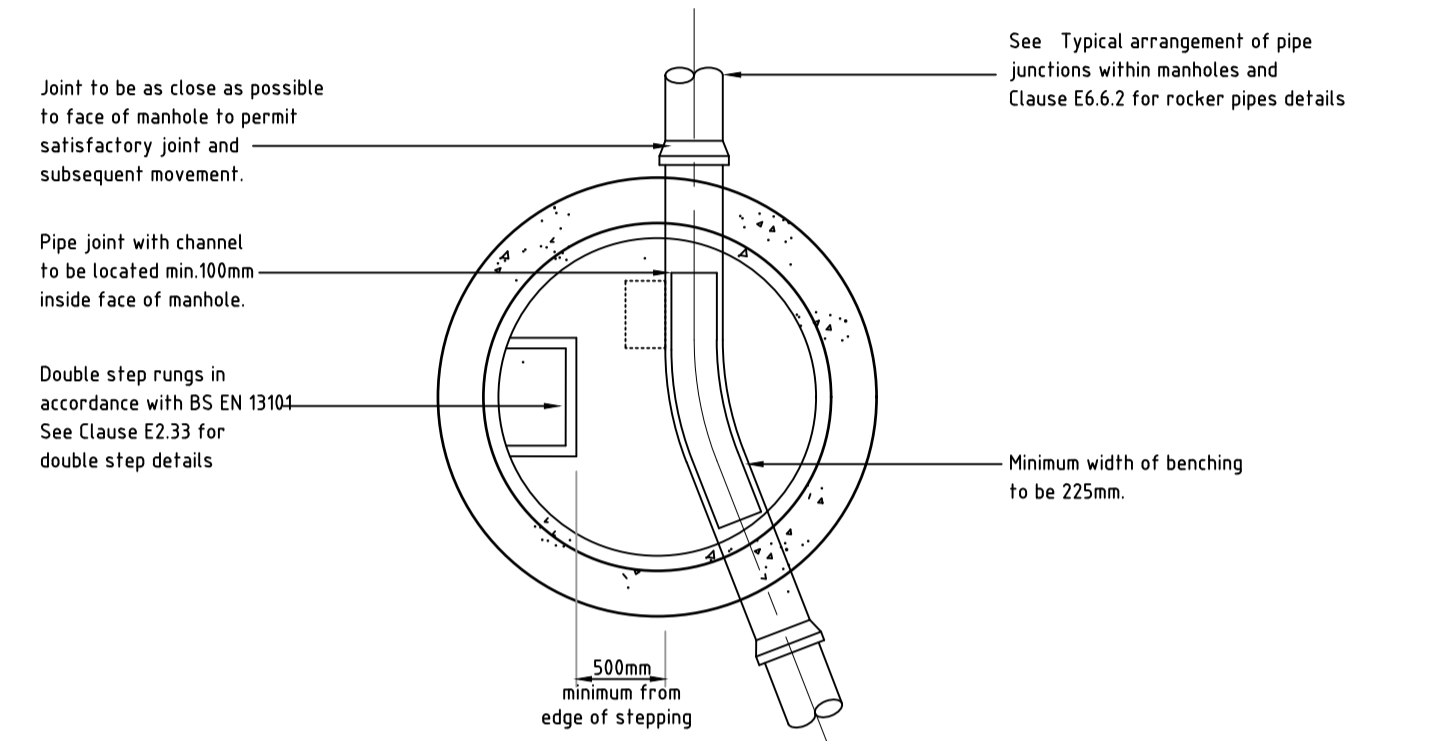

BEDDING FOR FLEXIBLE PIPES LESS THAN 900mm COVER UNDER ROADS
1:10

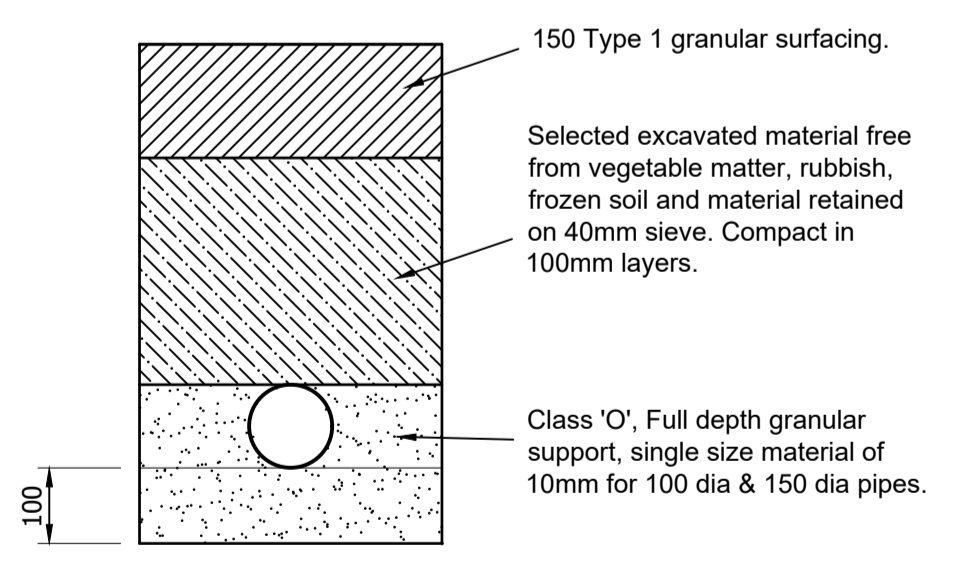

BEDDING FOR FLEXIBLE PIPES 900-1200mm COVER UNDER ROADS
1:10

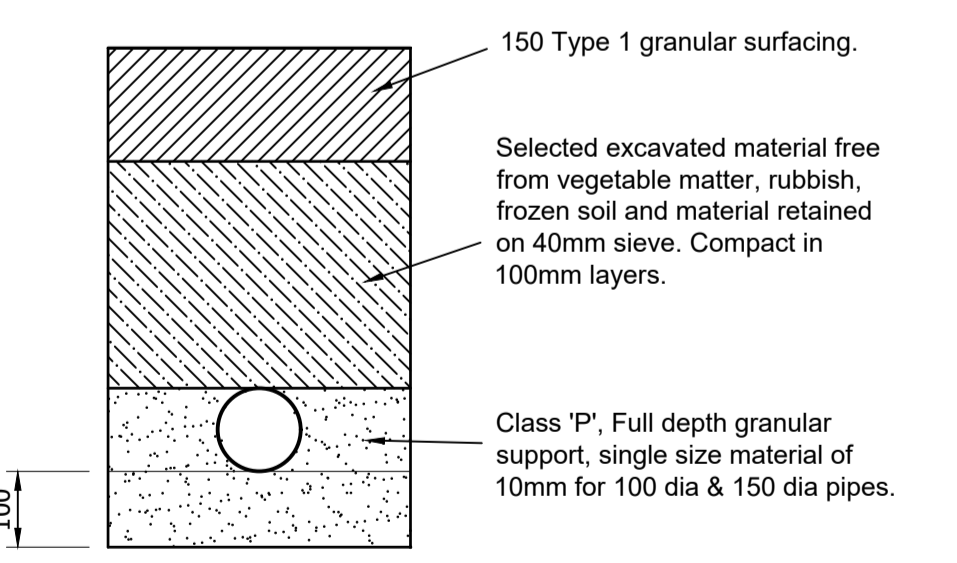

BEDDING FOR FLEXIBLE PIPES 1200-2000mm COVER UNDER ROADS
1:10

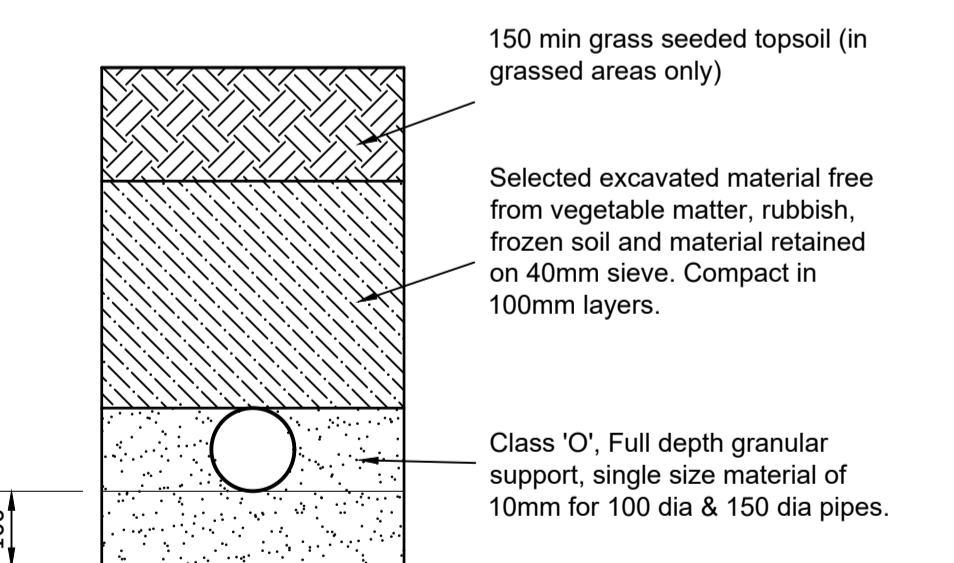

BEDDING FOR FLEXIBLE PIPES UP TO 1500mm DEEP NOT UNDER ROADS
1:10

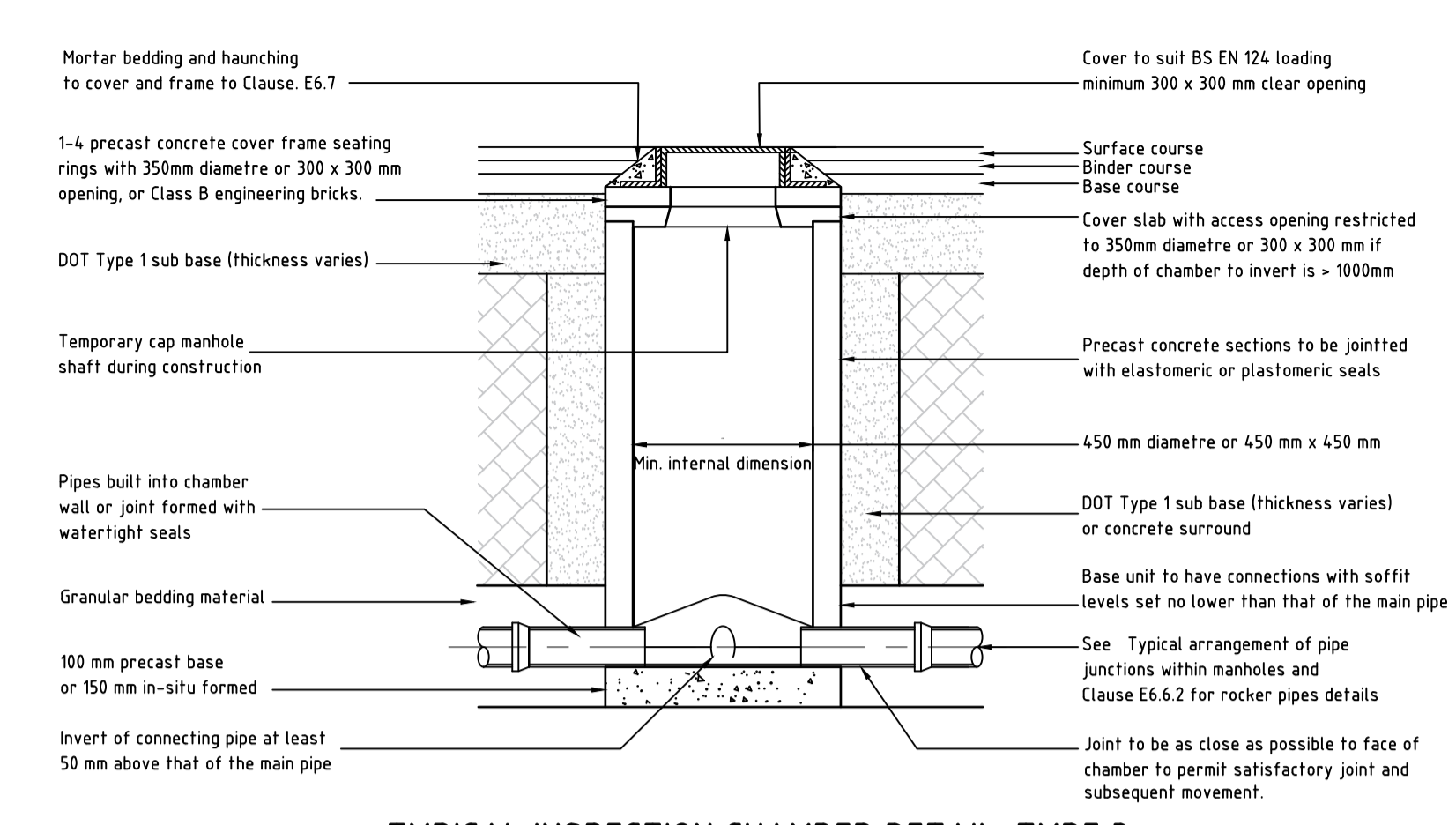

TYPICAL INSPECTION CHAMBER DETAIL-TYPE 3
(MAX DEPTH FROM C.L. TO SOFFIT OF PIPE IN AREAS SUBJECT TO VEHICLE LOADING 3000MM, NON-ENTRY)
NOTE: Where the access chamber is in the highway the Highway Authority can have specific requirements

ADOPTABLE DRAINAGE INSPECTION CHAMBERS / MANHOLES
1:25

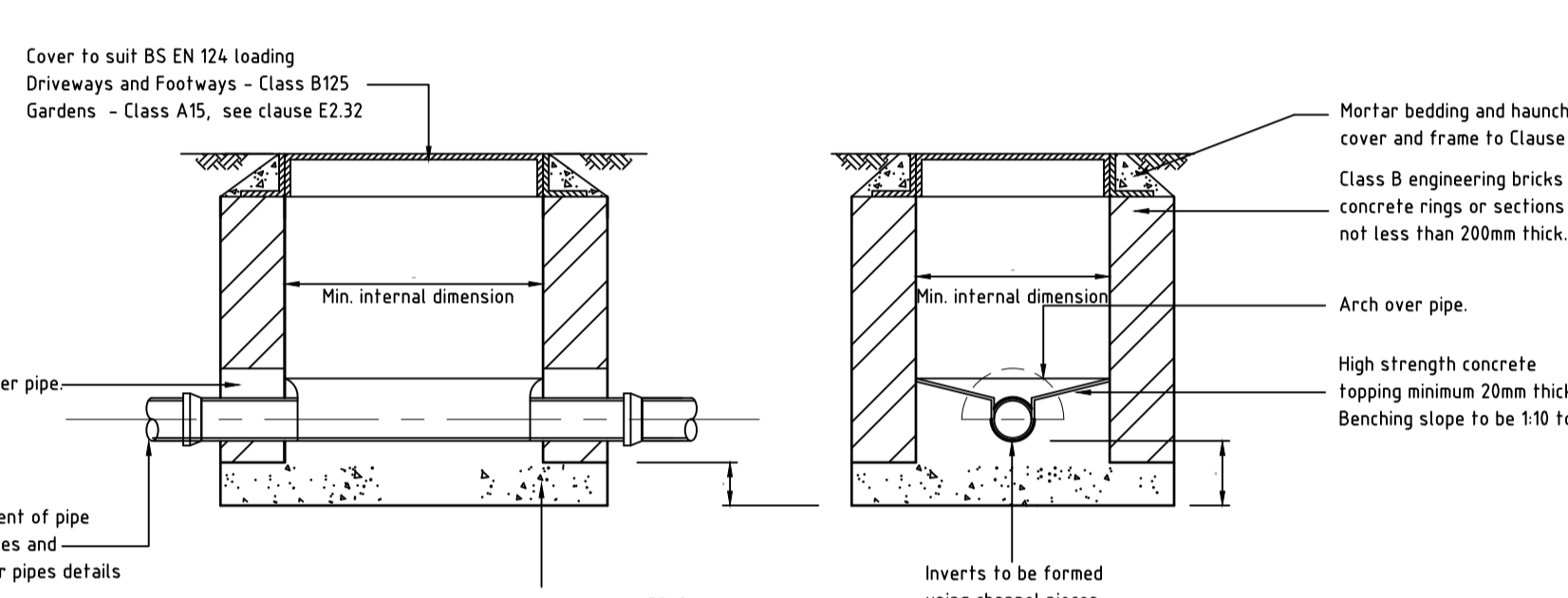

INSPECTION CHAMBER DETAIL - TYPE 4
(MAX DEPTH FROM C.L. TO SOFFIT OF PIPE 1m, no entry)

NOTE: Internal dimensions of manhole with minimum internal dimensions 450x600mm but manhole width should be increased for pipes larger than 150mm dia. to give 150mm benching each side with the brickwork/masonry units corbelled down to suit cover.
The use of precast rectangular concrete manhole units with 150mm grade GEN3 concrete surround (designed to BRE Special Digest 1 Concrete in Aggressive Ground) is permitted.

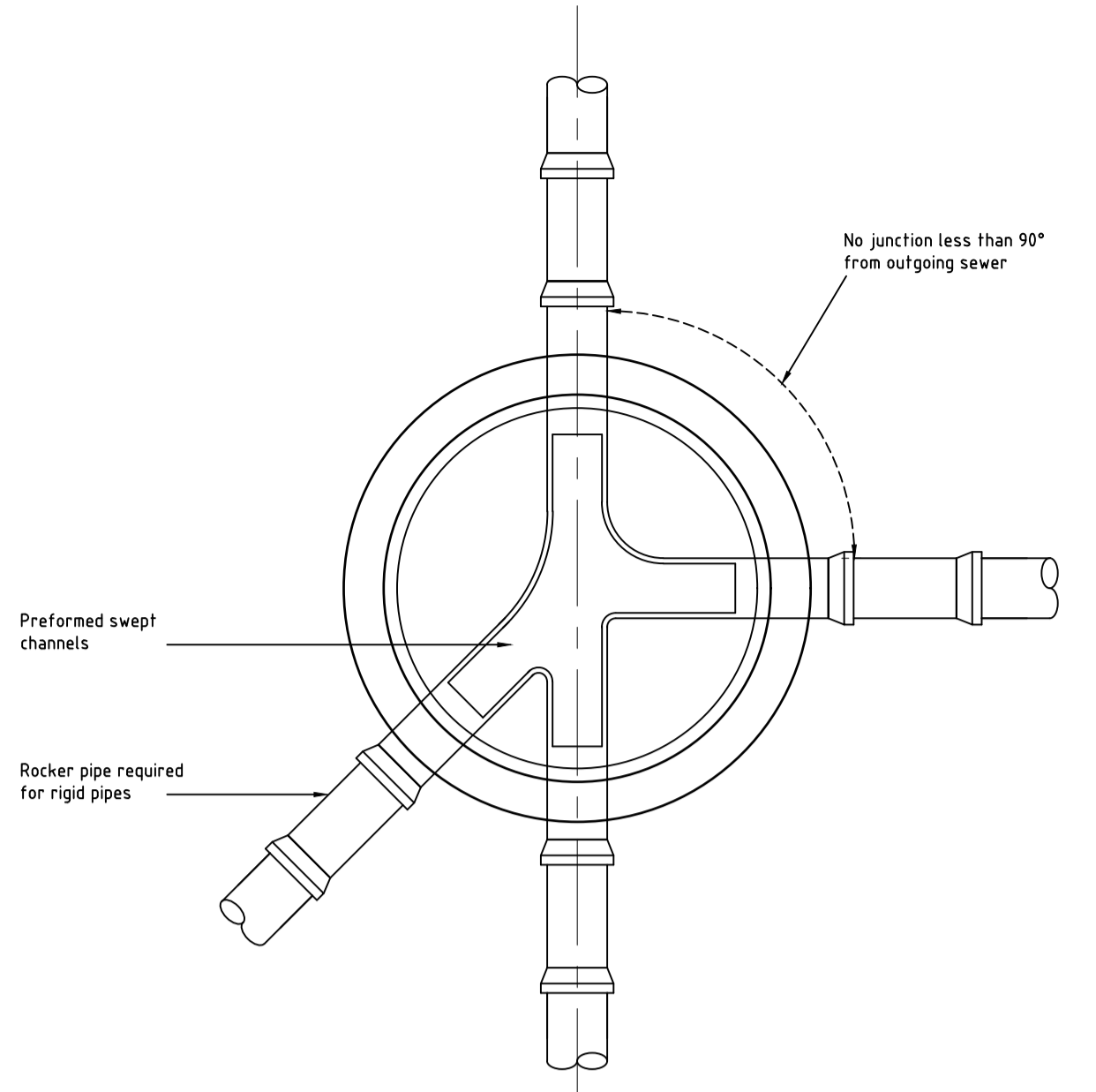

TYPICAL ARRANGEMENT FOR PIPE JUNCTIONS WITHIN MANHOLES

Alternative manhole base layouts to Figure B.20
Scale 1:25

Rigid pipes built into manhole should have a flexible joint as close as feasible to the external face of the structure and the length of the next rocker pipe should be as shown

NOMINAL DIAMETRE (MM)	MAXIMUM EFFECTIVE LENGTH (MM)
150 - 600	600
601 - 750	1000
over 750	1250

All pipes entering the bottom of the manhole to have soffits level.

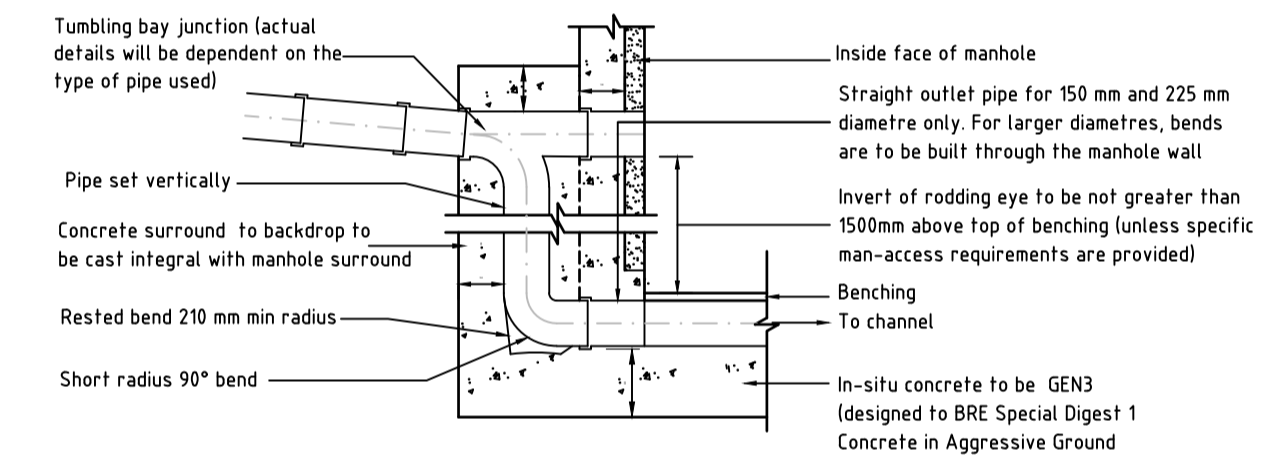

VERTICAL BACKDROP DETAIL

Scale 1:25

TYPICAL PRECAST CONCRETE CHAMBER SHOWN SIMILAR DETAIL FOR BRICK CONSTRUCTION.

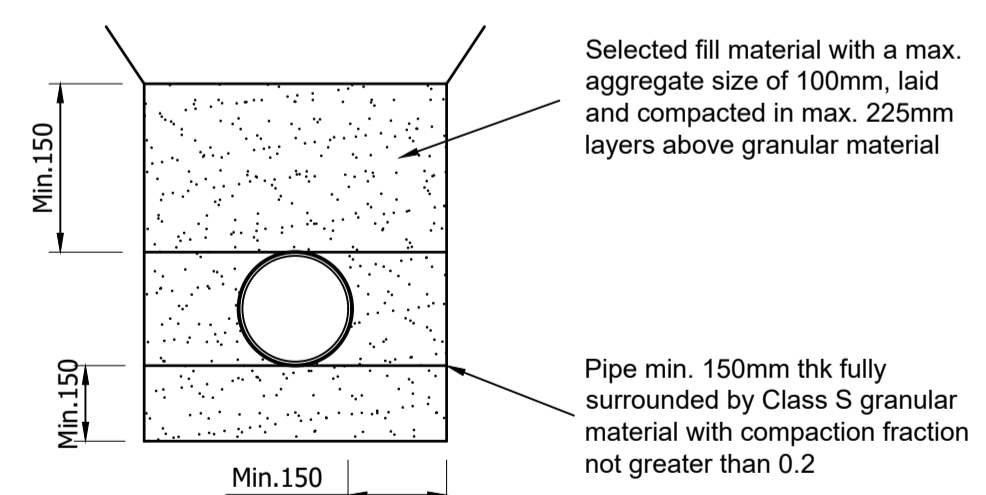

DETAIL FOR BEDDING OF VITRIFIED CLAY PIPES OF ADOPTABLE FOUL DRAINAGE & STORM CONNECTION TO MH9054
1:10

Date	By	Revision	QA'D	Chk'd	Ref
PRELIMINARY					

Cowan Consultancy
 Also at: Landguard Manor, Landguard Manor Road, Shanklin, Isle of Wight, PO37 7JB
 3 Turnberry House, 4400 Parkway, Whiteley, Fareham, Hampshire, PO15 7FJ
 Tel: 01489 577488, Fax: 01489 579873, consultants@cowanconsult.co.uk, www.cowanconsult.co.uk

Client: IMPERIAL HOMES SOUTH LTD.

Project: DEVELOPMENT AT BITTERNE PARISH CHURCH WHITES LANE, BITTERNE, SOUTHAMPTON

Title: INFRASTRUCTURE STORM & FOUL WATER DRAINAGE STANDARD DETAILS (2/2)

Date	MAY 2023	Scale	AS SHOWN @ A1	Dr. No.	
Drawn	HS	Chk'd	TB	QA'D	TB
					456146/205P