

Mixergy®

Technical specifications

For stainless steel hot water cylinders

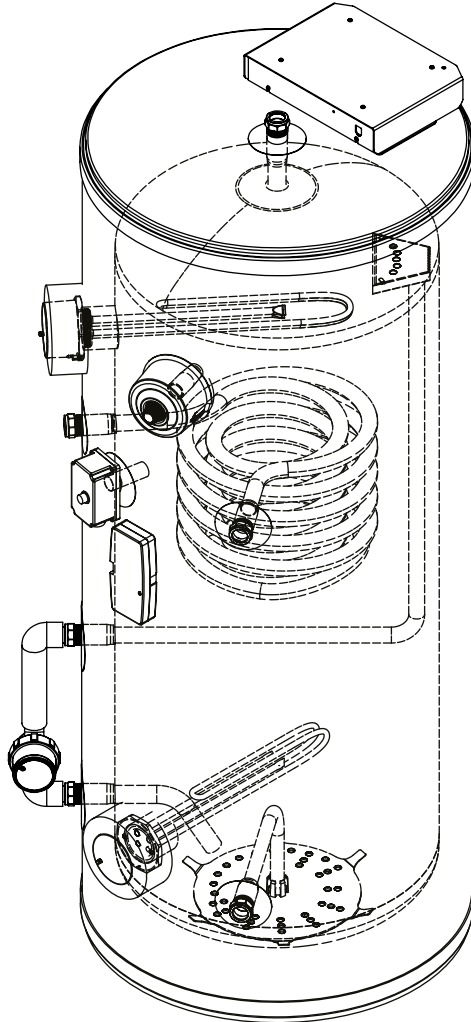

Mixergy Ltd
2 Canal View
Wharf Farm
Cassington
Oxfordshire
OX29 4DB

General technical data

Max. supply pressure to pressure reducing valve	1 MPa (10 bar)
Operating pressure	0.3 MPa (3 bar)
Expansion vessel charge pressure	0.3 MPa (3 bar)
Expansion relief valve setting	0.6 MPa (6 bar)
P&T relief valve setting (pressure)	0.7 MPa (7 bar)
P&T relief valve setting (temperature)	90 °C
Thermostat cut-out temperature	80 °C
Adjustable temperature range (digital)	50 - 65 °C
Coil max. working pressure (indirect)	0.35 MPa (3.5 bar)
Immersion heater(s) rating	230-240 V~ 2.7-3.0 kW
Immersion heater(s) specification	EN 60335-2-73
Immersion heater(s) type	356 mm Incoloy

About our cylinders

The Mixergy cylinder is a hot water storage cylinder which uses thermal stratification on charge (direct and indirect) and discharge (direct, indirect, lite and heat pump).

This stratification technology allows the Mixergy cylinder to partially heat (or 'charge') the water, reducing heat losses, improving available renewable capacity and allowing for exploitation of smart tariffs.

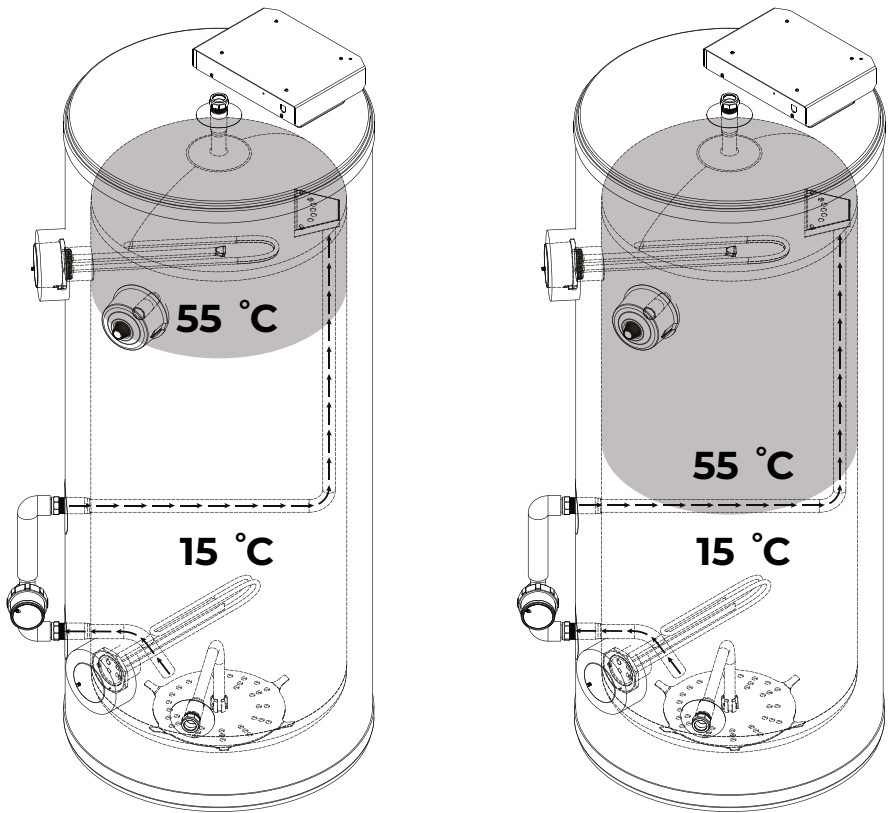

Additional components

- Monobloc kit incl. pressure reducing valve, check valve, pressure and temperature relief valve and expansion relief valve
- Tundish
- Expansion vessel incl. mounting bracket and 3/4" x 22mm adapters
- 3 kW immersion heater(s) 1.3/4" BSP (fitted)
- High limit thermostat (indirect only, fitted)
- 2-port diverter valve V4043H1056 (indirect/heat pump only)
- Powerline to ethernet adapter TL-PA4010
- Ethernet cable
- User guide

Model specifications

Cylinder model	90		120		150		180		210		300
Nominal dia. (mm)	478	478	580	478	580	478	580	478	580	580	
ErP rating DIR	B	B		B		B		B		B	
ErP rating IND	C	B		B		B		C		C	
Standing loss* (kWh/24h)	0.54 - 1.32	0.54 - 1.08		0.54 - 1.15		0.54 - 1.27		0.54 - 1.37		0.54 - 1.75	
Coil rating (IND ONLY)	20	20		22		24		24		24	
Cylinder height (mm)	1141	1329	1050	1517	1236	1767	1418	2081	1608	2125	
Empty weights (kg)**											
Direct	23	28	32	35	37	38	42	40	47	57	
Indirect / Lite	--	32	37	40	42	44	47	47	52	62	
Full weights (kg)**											
Direct	113	148	162	185	187	218	217	250	262	362	
Indirect / Lite	--	152	167	190	192	224	222	257	267	367	

Model specifications

Cylinder model	90		120		150		180		210		300
Nominal dia. (mm)	478	478	580	478	580	478	580	478	580	580	
Minimum reheat time (15 to 65 °C) - Direct	30 min	30 min	44 min	30 min	44 min	30 min	44 min	30 min	44 min	44 min	
Minimum reheat time (15 to 65 °C) - Indirect	12 min										
70% charge reheat time (15 to 65 °C) - Direct	73 min	98 min	123 min	147 min	172 min	245 min					
70% charge reheat time (15 to 65 °C) - Ind / Lite	--	14 min	17 min	21 min	23 min	31 min					
70% charge reheat time (15 to 65 °C) - HP	4 min	6 min	7 min	9 min	10 min	14 min					
100% charge reheat time (15 to 65 °C) - Direct	105 min	140 min	176 min	210 min	246 min	350 min					
100% charge reheat time (15 to 65 °C) - Ind / Lite	--	20 min	25 min	30 min	33 min	45 min					
100% charge reheat time (15 to 65 °C) - HP	6 min	9 min	11 min	13 min	15 min	21 min					

* Standing loss figures given at minimum and maximum charge, for SAP calculations please use the maximum heat loss value.

** For cylinders with an exchanger assembly fitted, add 5kg to the cylinder weight.

Heat pump exchanger specifications

Exchanger construction	Copper brazed 304 SS
Exchanger rating (kW)**	44
Max. operating pressure	2 MPa (20 bar)
Max. flow rate	65 L/min (3.8 m ³ /hr)
Connections	3/4" ISO-G (BSPP) M
Equivalent coil area (m²)***	3 m ²

** Tested at 80 C, 15 L/min primary flow as per BS EN 12897-2016

*** Equivalently performant coil S.A for SAP 10 calculations

Heat pump exchanger specifications

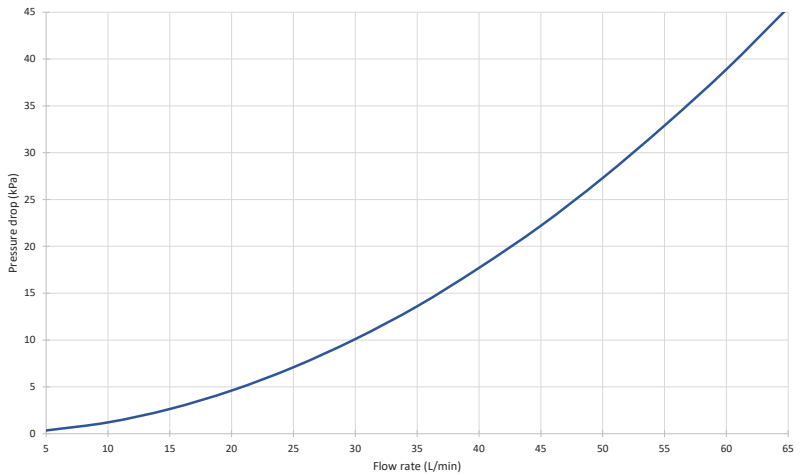
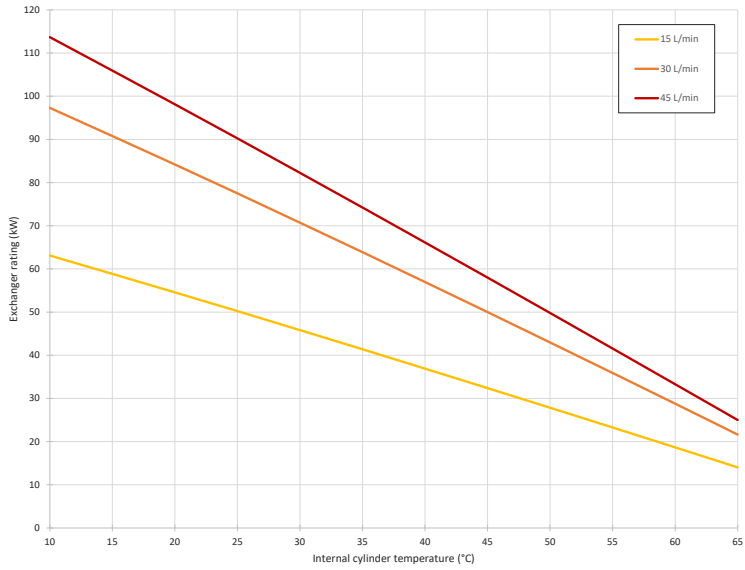

Schematic: Direct

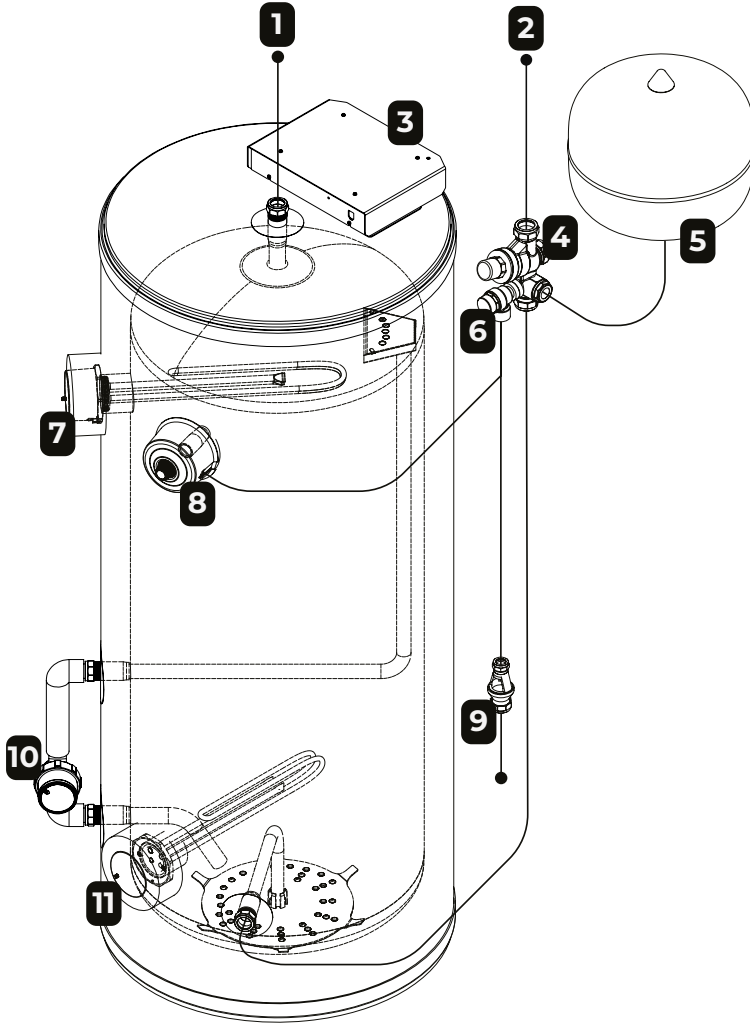

1 Hot draw off

2 Cold feed

3 Controller

4 Cold water control group

5 Expansion vessel

6 Expansion relief valve

7 Primary immersion

8 P&T relief valve

9 Tundish and discharge pipe

10 Pump assembly

11 Backup immersion (if fitted)

Schematic: Indirect

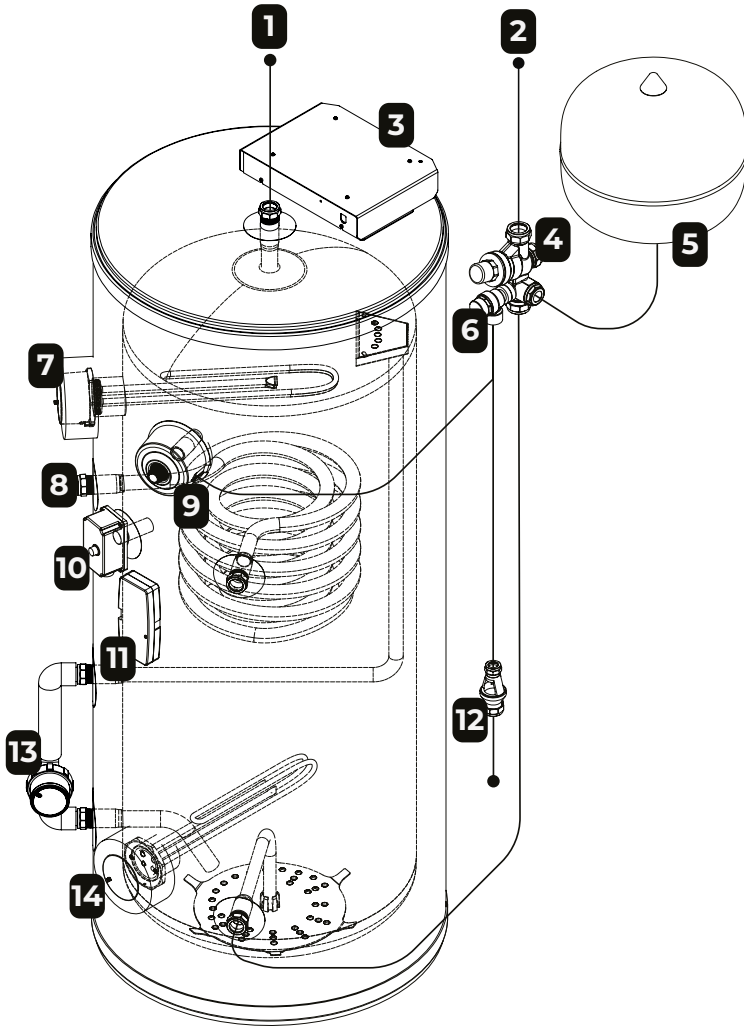

1	Hot draw off	8	Indirect coil ports
2	Cold feed	9	P&T relief valve
3	Controller	10	High limit safety stat
4	Cold water control group	11	Indirect junction box
5	Expansion vessel	12	Tundish and discharge pipe
6	Expansion relief valve	13	Pump assembly
7	Primary immersion	14	Backup immersion (if fitted)

Schematic: Heat pump

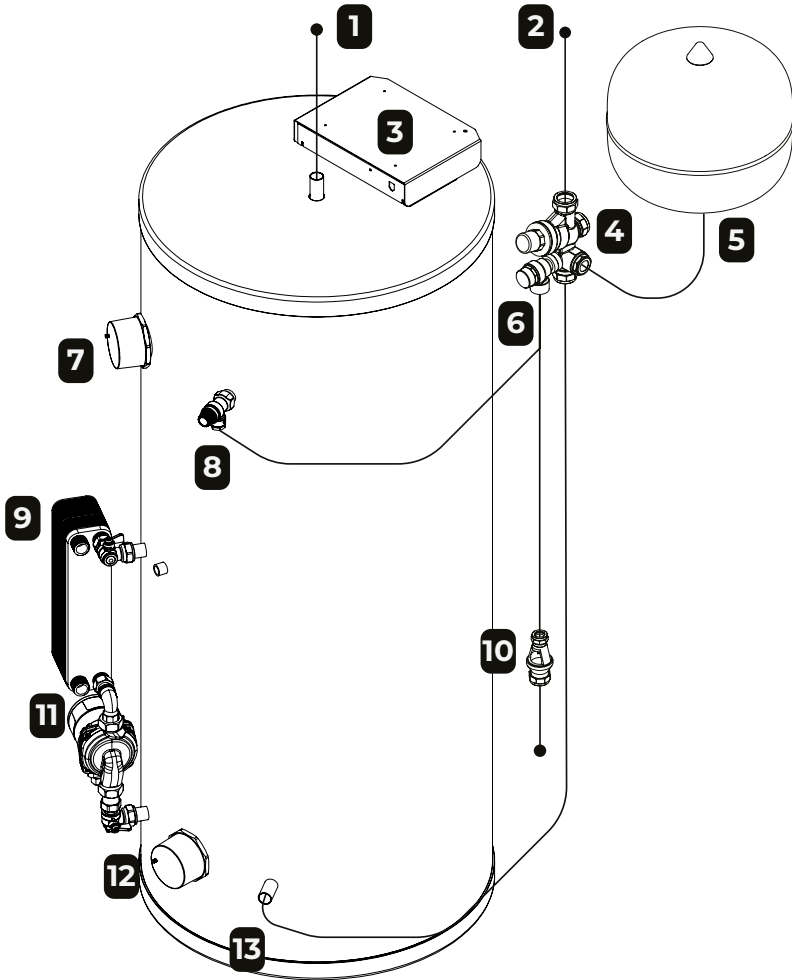

1	Hot draw off	8	P&T relief valve
2	Cold feed	9	Plate heat exchanger
3	Controller	10	Tundish and discharge pipe
4	Cold water control group	11	Circulation pump
5	Expansion vessel	12	Primary immersion
6	Expansion relief valve	13	Inlet diffuser
7	Backup immersion (if fitted)		

Hydraulic installation diagram

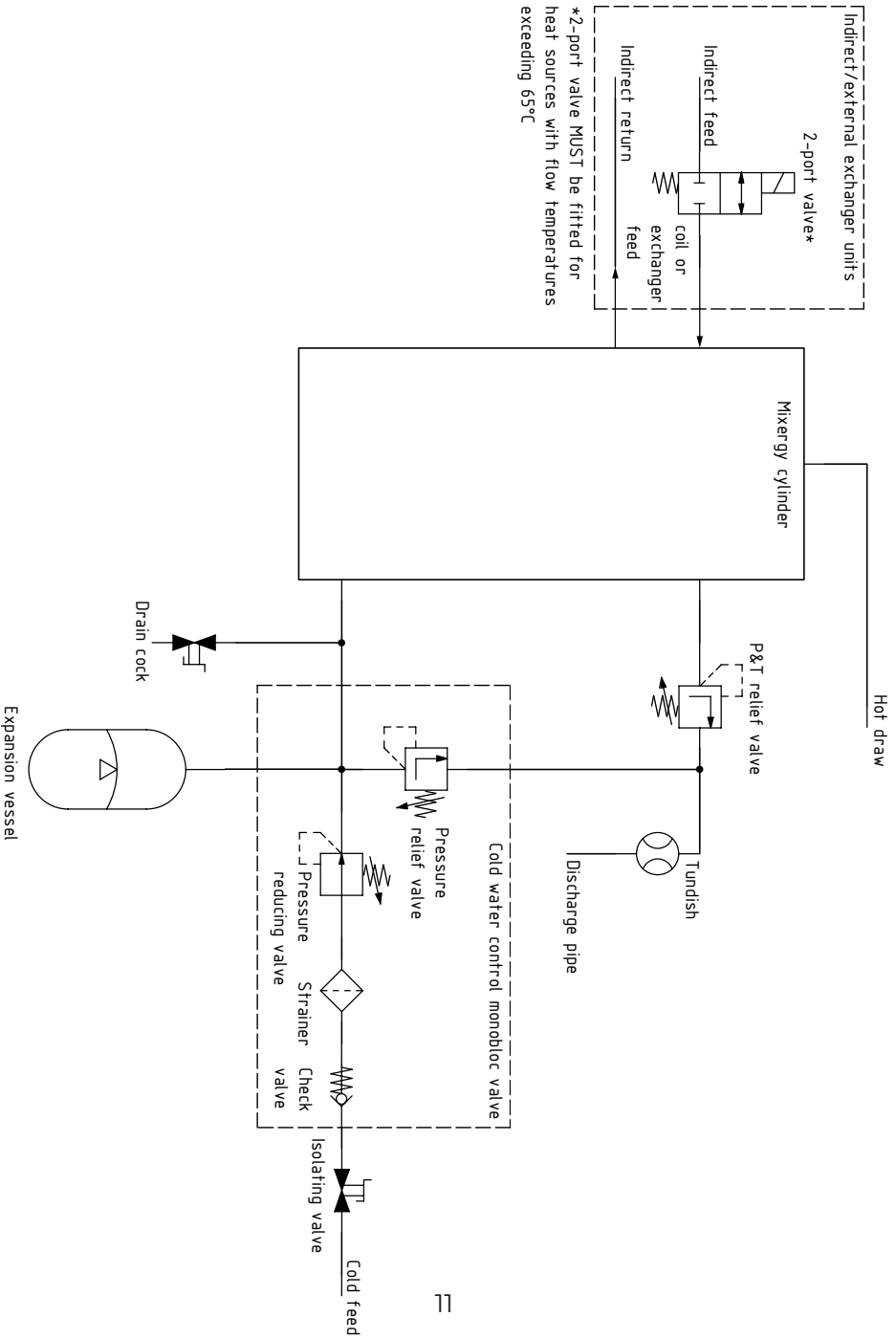

Installation space requirements

The installation area should be able to cope with the weight, incoming pipes and discharge pipe when full. Full weights are listed on page 4 of this document.

Positioning of the cylinder

Position of the cylinder should suit the installation; all connections should be to the front for ease of access. Ensure suitable space is left for access for repair and/or replacement of immersions and valves etc. **Ensure at-least 300mm of vertical clearance above the cylinder.** Refer to page 4 for cylinder heights and the diagram below for guidelines on space requirements:

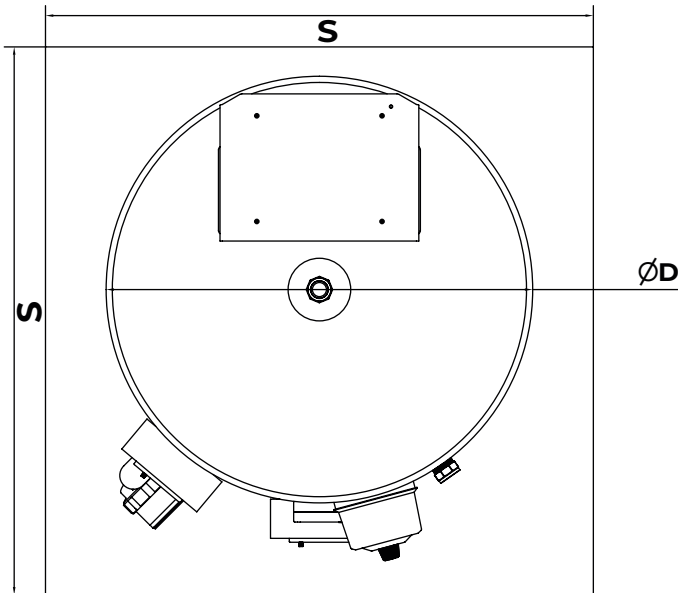

Nominal diameter $\varnothing D$ (mm)	Space requirement S (mm)
478	580
580	700