

KD 315 L1 Circ.duct fan

Centrifugal circular duct fan

Item Number: [25336](#)

Variant: 230V 1~ 50Hz

- High efficiency – low noise
- Speed-controllable
- Integral thermal contacts
- Can be installed in any position
- Maintenance-free and reliable

The KD series have external rotor motors with a new type of mixed flow impeller which reduces the external dimensions of the fans. These fans have a high capacity in relation to their compact design. Brackets are supplied with the fans to make installation easier.

The FK mounting clamp facilitates easy installation and removal and prevents the transfer of vibrations to the duct. To protect the motor from overheating the fan has integral thermal contacts with manual reset. The casing is manufactured from galvanised sheet steel.



Technical parameters

Nominal data		
Voltage (nominal)	230	V
Frequency	50	Hz
Phase(s)	1~	
Input power	372	W
Input current	1.62	A
Impeller speed	2,595	rpm
Air flow	max 0.593	m ³ /s
Capacitance of capacitor	10	µF
Temperature of transported air	max 70	°C
Max temperature of transported air, when speed controlled	70	°C
Sound data		
Sound pressure level at 3m (20m ² Sabin)	54	dB(A)
Protection/Classification		
Enclosure class, motor	IP44	
Insulation class	F	

Data according to ErP

ErP ready

Not ErP relevant

Dimensions and weights

Duct dimension; Circular, inlet

315 mm

Duct dimension; Circular, outlet

315 mm

Weight

9 kg

Others

Duct connection type

Circular

Motor type

AC

Performance

Performance curve

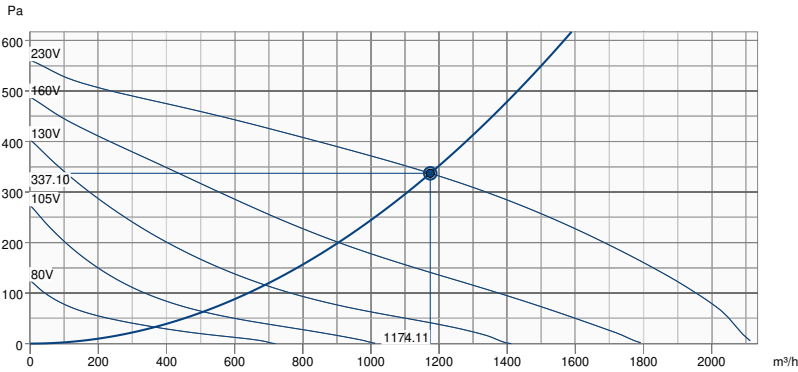

Hydraulic data

Required air flow	1174.14 m³/h
Required static pressure	337 Pa
Working air flow	1174.11 m³/h
Working static pressure	337 Pa
Air density	1.204 kg/m³
Power	364.9 W
Fan control - RPM	2609 rpm
Current	1.60 A
SFP	1.119 kW/m³/s
Control voltage	230.0 V
Supply voltage	230 V

Sound power level		63	125	250	500	1k	2k	4k	8k	Total
Inlet	dB(A)	59	69	72	75	74	71	69	67	80
Outlet	dB(A)	55	69	71	73	75	76	71	65	81
Surrounding	dB(A)	33	36	44	60	50	47	48	40	61
Sound pressure level at 3m (20m² Sabine)	dB(A)	-	-	-	-	-	-	-	-	54
Sound pressure level at 3m free field	dB(A)	-	-	-	-	-	-	-	-	40

Dimension

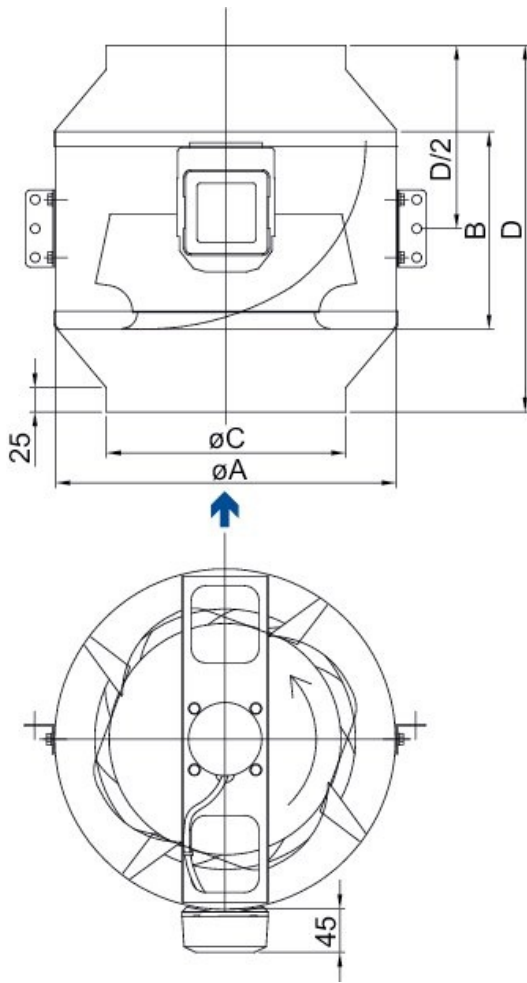

øA	B	øC	D	D/2
353	205	313	305	152.5

Wiring

230V 1~

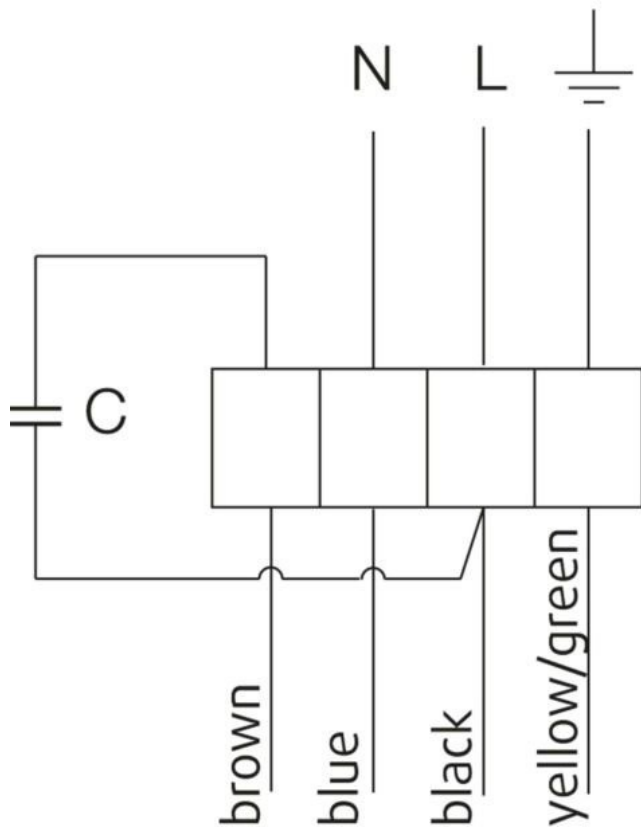

U1 = blue = blau

U2 = black = schwarz

Z = brown = braun

PE = yellow/green = grün-gelb

Accessories

- FRQ5S-E-6A (37421)
- REE 2 Speed control (5316)
- REU 3 Speed control (5005)
- SG 315 Protection guard (5611)
- CB 315-6,0 400V/2 Duct heater (5374)
- DTV500A (96807)
- HR1 Room Humidistat (215150)
- RT 0-30 Room Thermostat (5151)
- CB 315-3,0 230V/1 Duct heater (5386)
- CBM 315-9,0 400V/3 Duct heater (5485)
- CWK 315-3-2,5 Duct cooler,circ (30025)
- FGR 315 Filter cassette (1818)
- LDC 315-900 Silencer (5197)
- VBC 315-2 Water heating batt (5461)
- VBF 315 Water heating battery (1734)
- RE 3 Speed control (5001)
- REPT 6 Digital regulator (5698)
- REV-3POL/03-7,5kW R/Y (33978)
- VKK-315 Back draft damper (1628)
- CO2RT-R-D Transmitter (6993)
- FRQS-E-6A (37419)
- Presence detector/IR24-P (6995)
- CB 315-12,0 400V/3 Duct heater (5387)
- CB 315-9,0 400V/3 Duct heater (5375)
- CBMF 315-9,0 400V/3 Duct heater (12354)
- FFR 315 Filter cassette (1779)
- FK 315 Fast clamp (1613)
- RSK-315 Back draft damper (5604)
- VBC 315-3 Water heating batt (9844)
- VK-30 Louvre shutter (5641)

Documents

- 132780_FANS_INSTRUCTIONS_OUTSIDE_EU_A002.PDF

Specification

The Circular duct fan is reliable in operation and maintenance-free and has a mixed flow impeller. In addition to that the fan achieves a high efficiency at low noise level. The box consists of crimped and electroplated steel plate, which is powder-coated. For an easy assembling the installation cramps are fixed to the fan. The provided standard connecting collar of the FK - mounting clamps assures an easy assembling and disassembling and avoids the transmission of vibration to the piping system. The assembling is possible in each fitting position. Furthermore the fan has a freewheeling radial impeller with backwards-curved impeller vane. The actuation is carried out by a maintenance-free, speed-controlled external rotor motor. Through dropping the tension, the fans can be speed-controlled with the help of a stepless thyristor or a 5-step transformer. The fans have integral thermal contacts with reset device according to EN 60335-2-80 for protecting the engine. For annealing the engine is designed inside the air flow. Completely with the impeller in two levels the engine is statically and dynamically weighed heavy according to DIN ISO 1940.