

Typical Manhole Detail - Type A1
Scale 1:20

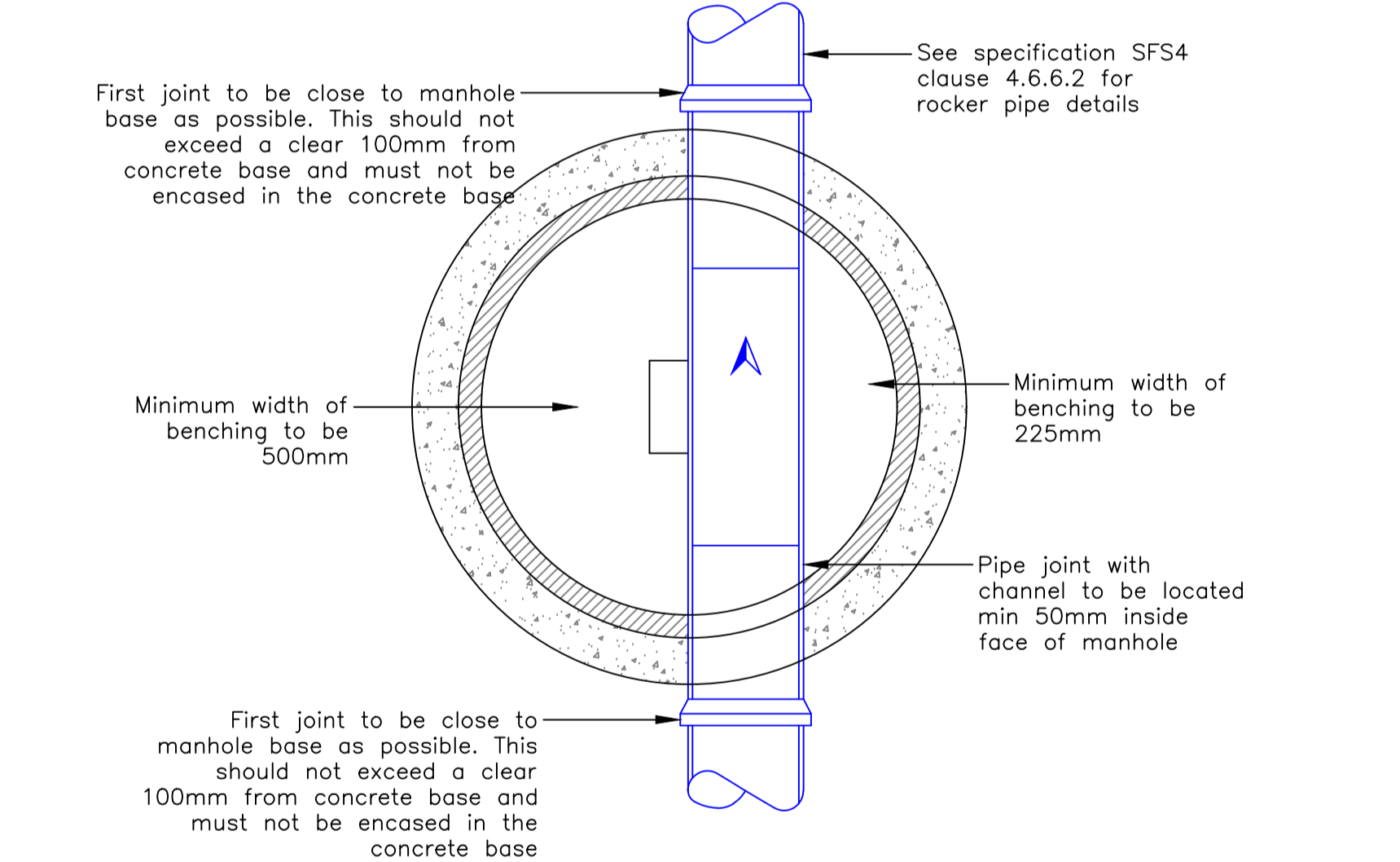

Sectional plan A - A
Scale 1:20

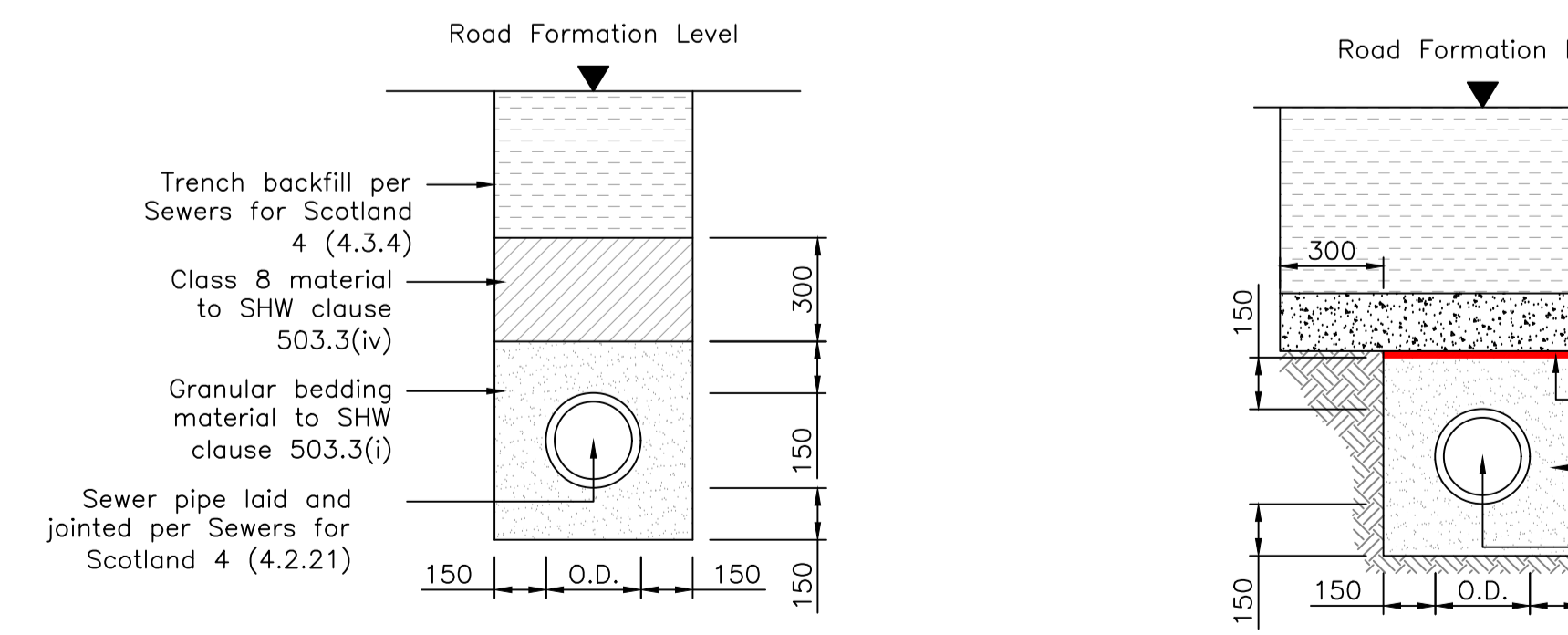

Class S Bedding for UPVC Pipes
Scale 1:20

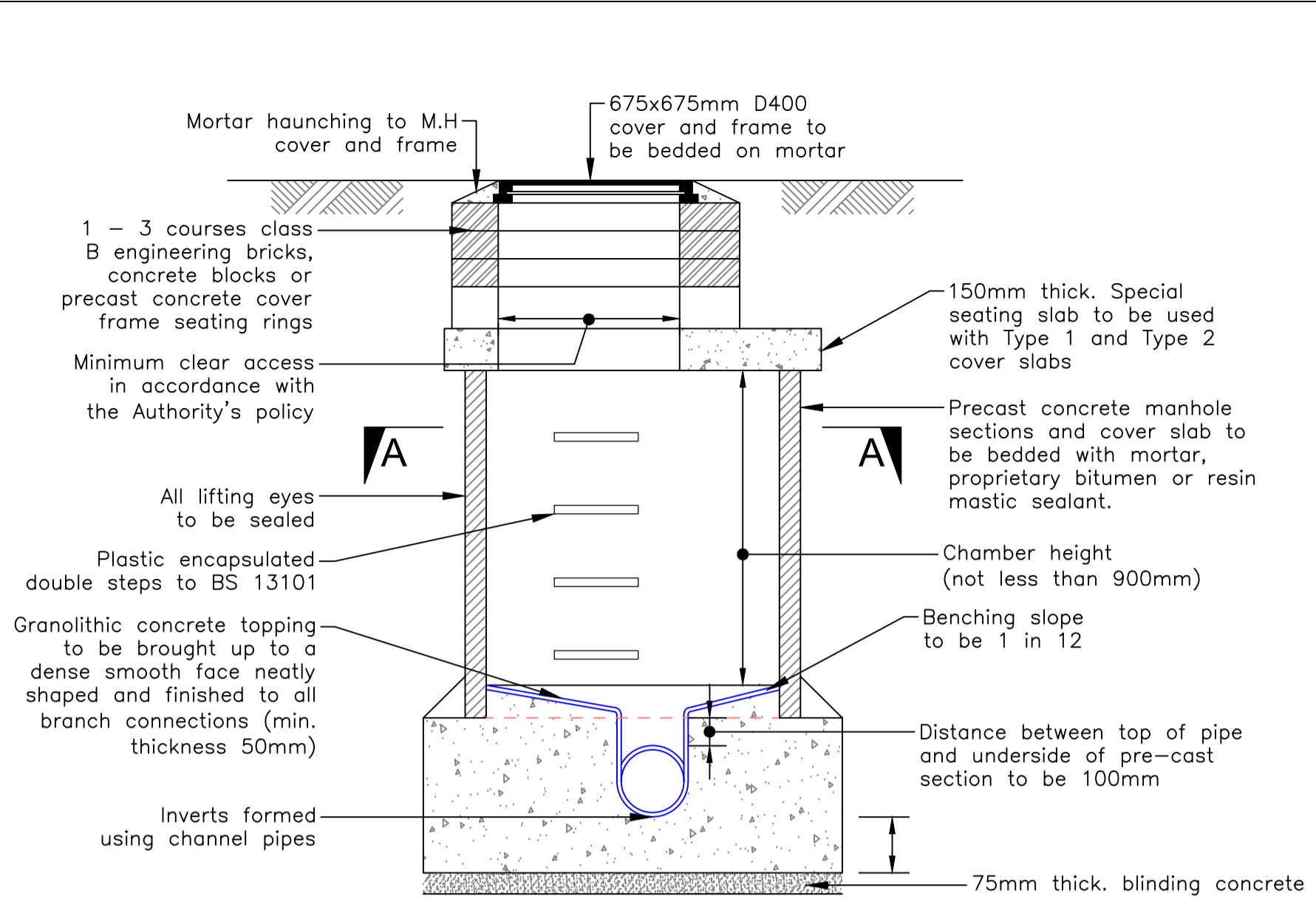

Typical Manhole Detail - Type B1
Scale 1:20

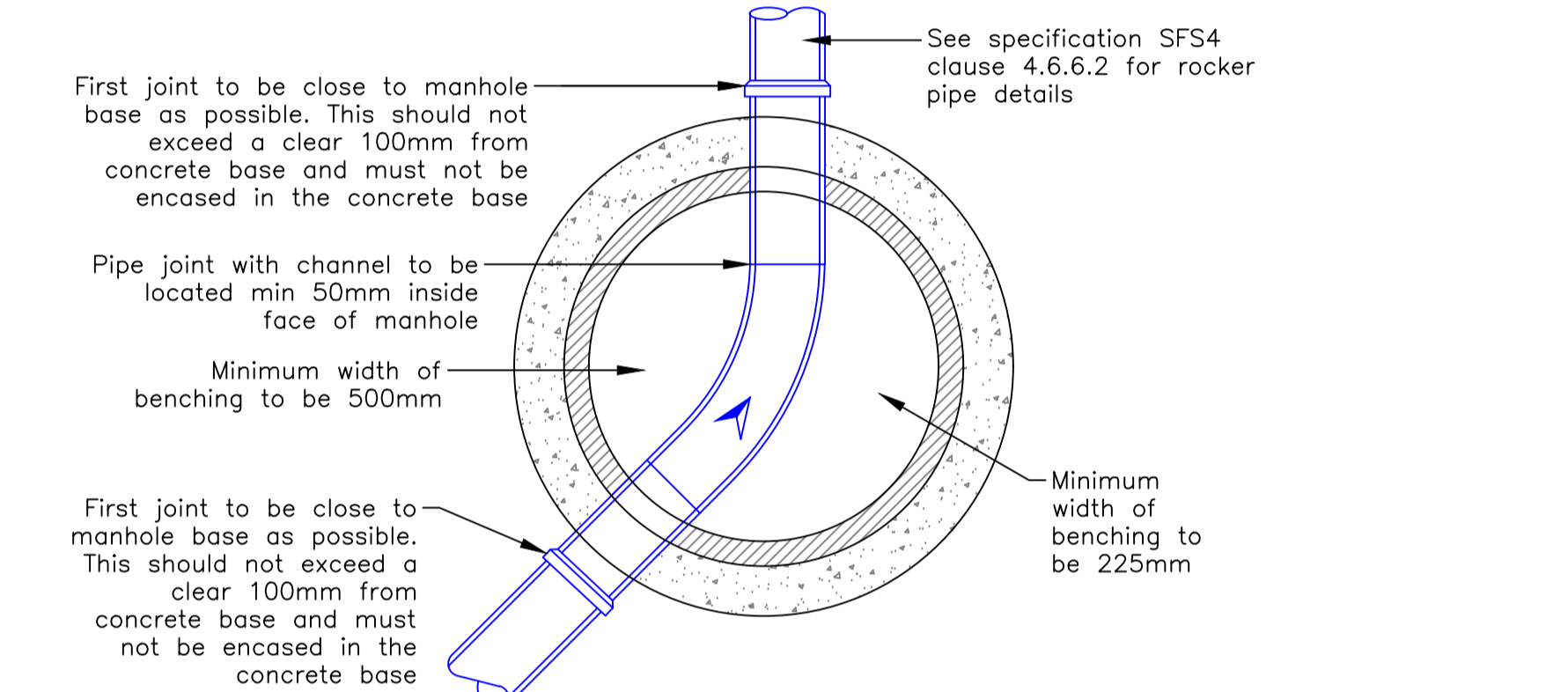

Sectional plan A - A
Scale 1:20

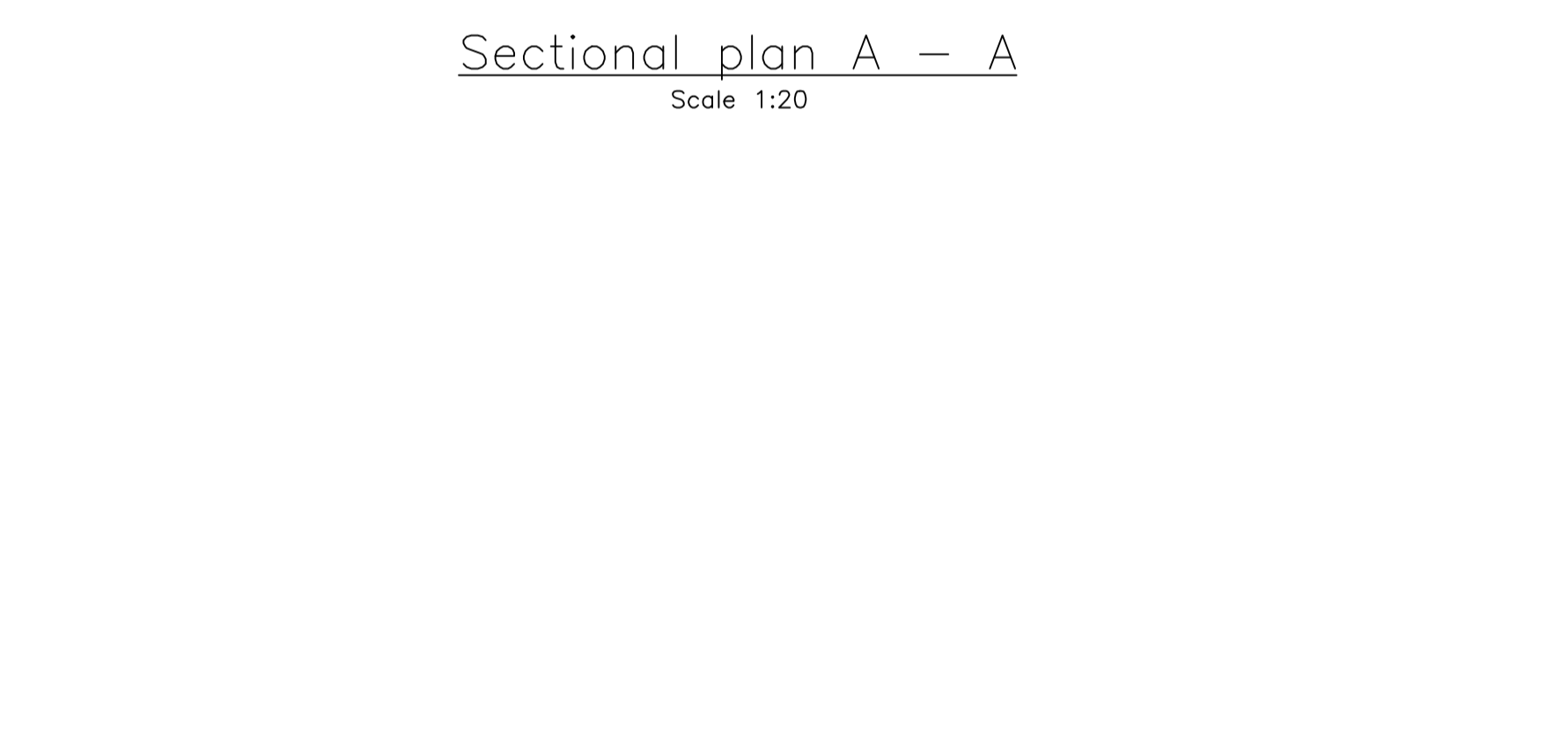

Sectional plan A - A
Scale 1:20

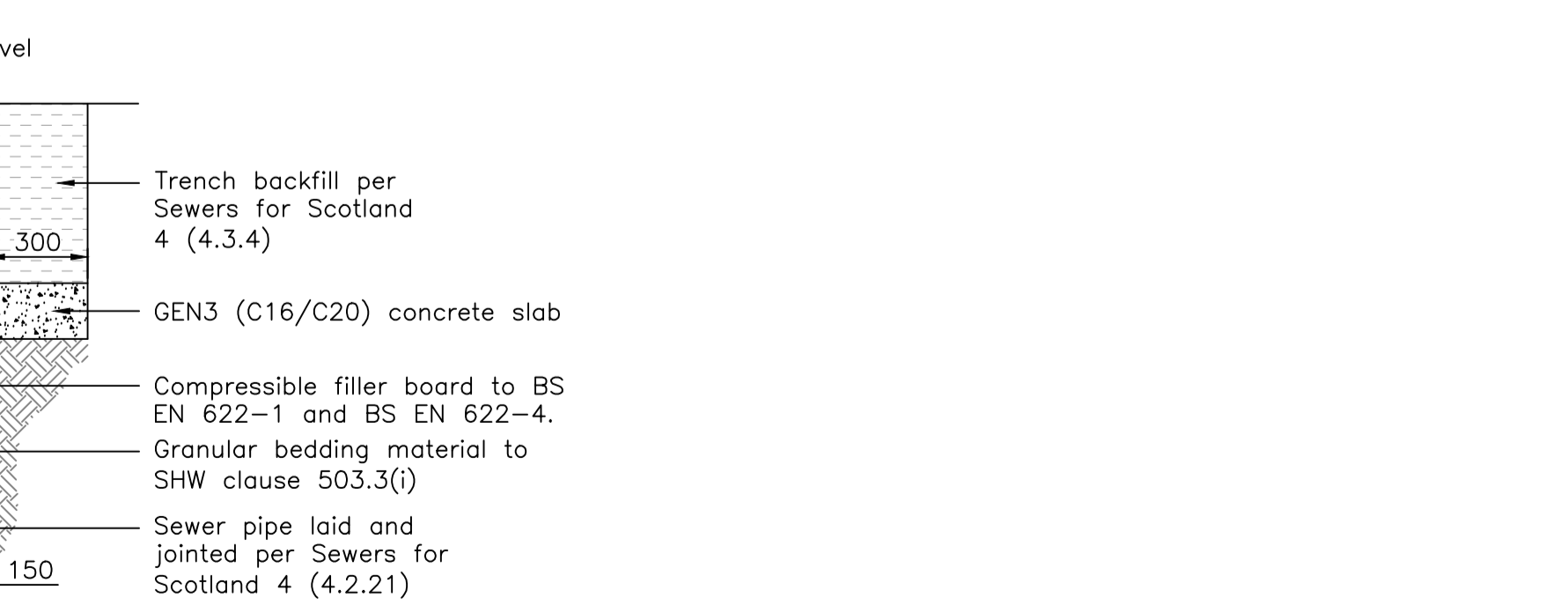

Concrete Slab Pipe Protection
(UPVC Pipes less than 1.2m Cover within Vehicular Areas)
Scale 1:20

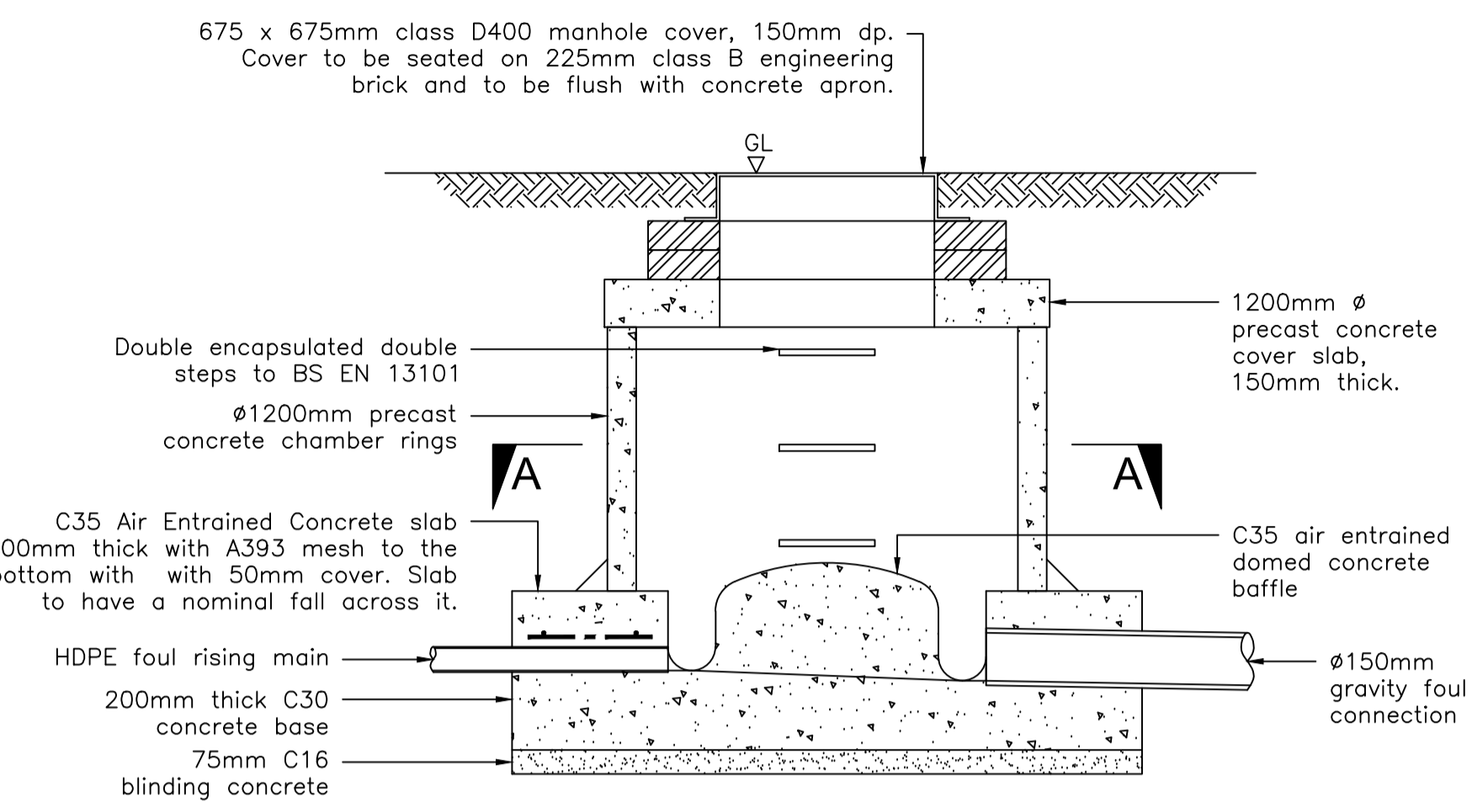

Typical Break Pressure Chamber Detail
Scale 1:20

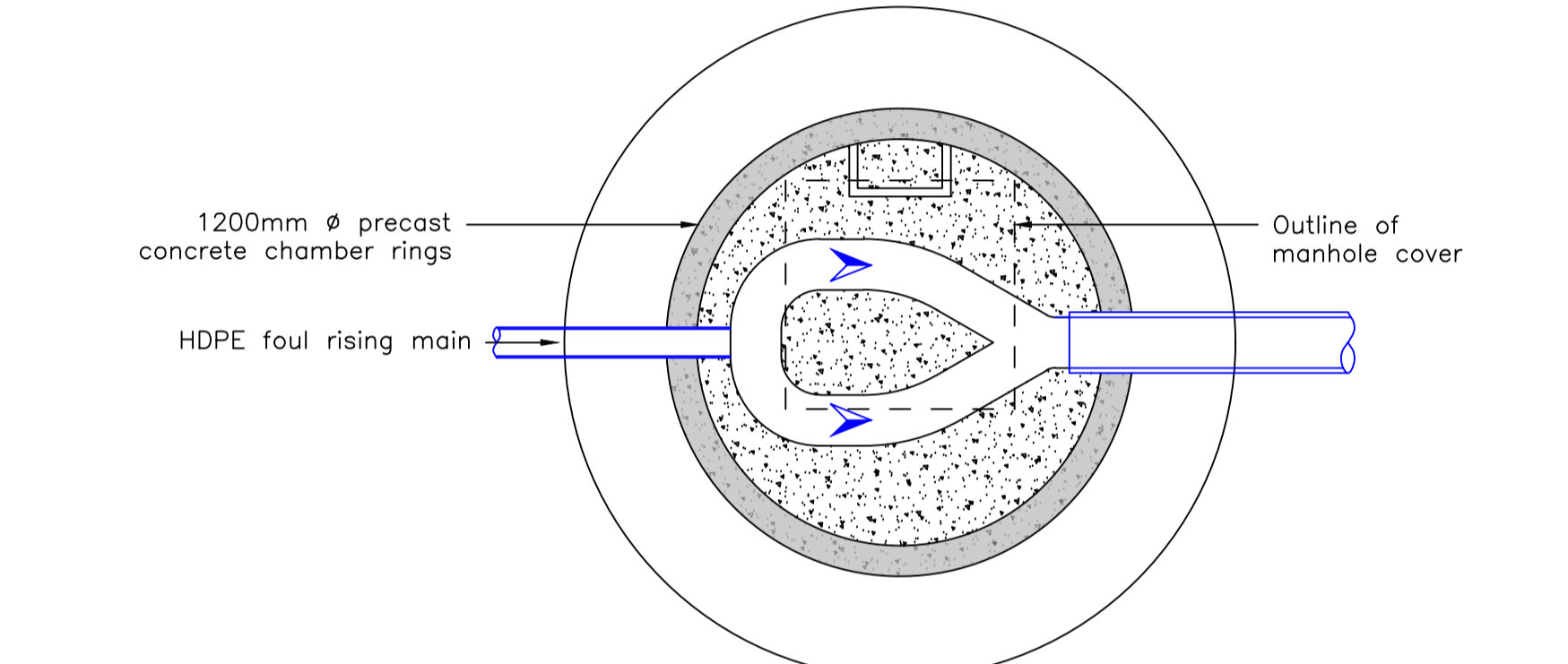

Sectional Plan A - A
Scale 1:20

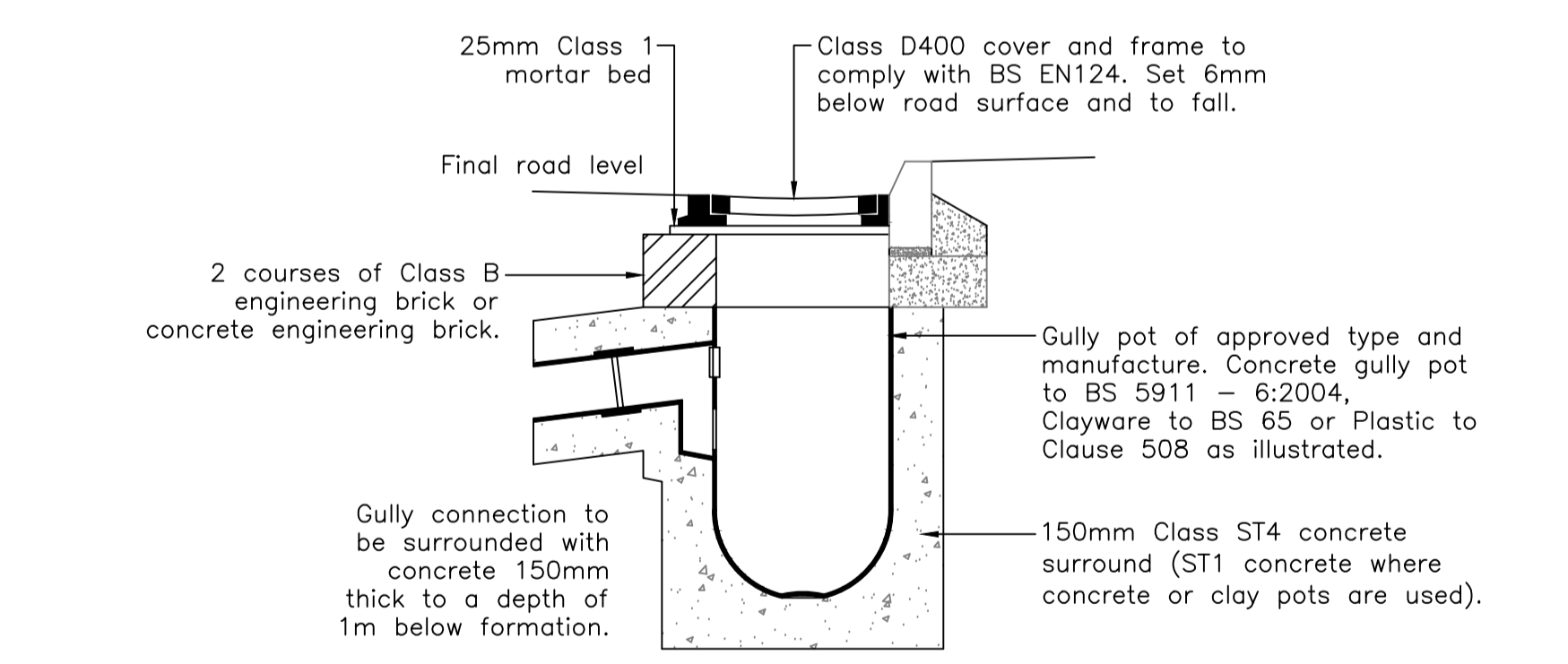

Typical Road Gully Detail
Scale 1:20

Do not scale from this drawing.			
SAFETY HEALTH AND ENVIRONMENTAL INFORMATION			
IN ADDITION TO THE HAZARD/RISKS NORMALLY ASSOCIATED WITH THE TYPES OF WORK DETAILED ON THIS DRAWING, NOTE THE FOLLOWING RISKS AND INFORMATION.			
RISKS LISTED HERE ARE NOT EXHAUSTIVE. REFER TO DESIGN ASSESSMENT FORM NO. DAF01			
CONSTRUCTION: LIVE PRIMARY ROUTE TRAFFIC (B9039). UTILITIES TO BE DIVERTED/PROTECTED			
DEMOLITION: NONE THAT WOULD NOT BE APPARENT TO A COMPETENT CONTRACTOR			
FOR INFORMATION RELATING TO USE, CLEANING AND MAINTENANCE SEE THE HEALTH AND SAFETY FILE.			
IT IS ASSUMED THAT ALL WORKS WILL BE CARRIED OUT BY A COMPETENT CONTRACTOR WORKING, WHERE APPROPRIATE, TO AN APPROVED METHOD STATEMENT.			
Notes:			
1. Do not scale from this drawing, only written dimensions are to be used.			
2. This drawing is to be read in conjunction with all architectural and engineering drawings, details and specifications.			
3. All work to comply with Highland Council's Roads and Transport Guidelines for New Developments.			
4. Road signs and markings to be in accordance with the Traffic Signs Regulations And General Directions 2016.			
5. Any discrepancies should be reported to the engineer immediately so clarification can be sought.			
6. For clarity this drawing should only be printed and read in colour.			
A	23/10/23	Drawing title updated, inset road gully and infiltration trench details removed. Scale details added.	HF AH AKF
Rev.	Date	Description	Drawn, Chkd, Appd.
FAIRHURST		Client: Castle Stuart Golf LLP	
Elvie House Beechwood Business Park WIGBESS IV2 3BW		CABOT	
Tel: 01463 724 544 Fax: 0844 381 4412			
Project Title: Cabot Highlands			
Drawing Title: Upgraded Access Typical Drainage Construction Details Sheet 1 of 2			
Scale at A1: As Shown		Status: Road Construction Consent	
Drawn: HF	Checked: AH	Approved: AKF	
Date: 14/07/2023	Date: 21/09/2023	Date: 21/09/2023	
Drawing No: 154163-PC-2110			Revision: A