

Typical New Road to Existing Road Tie-in Detail

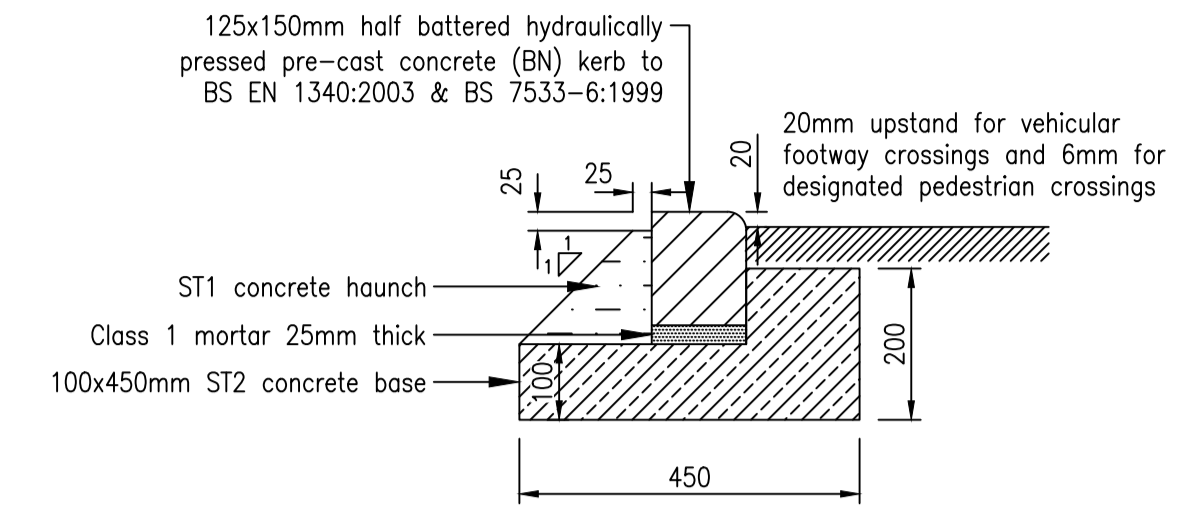

125 x 150 Bullnose (BN) Kerb

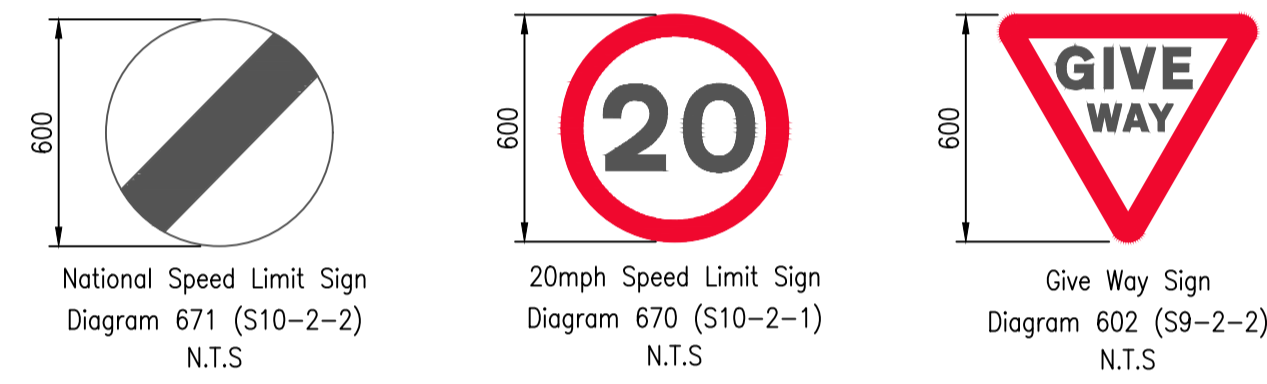

Note: Sign ref. S01 and S02 to be mirrored for north approach

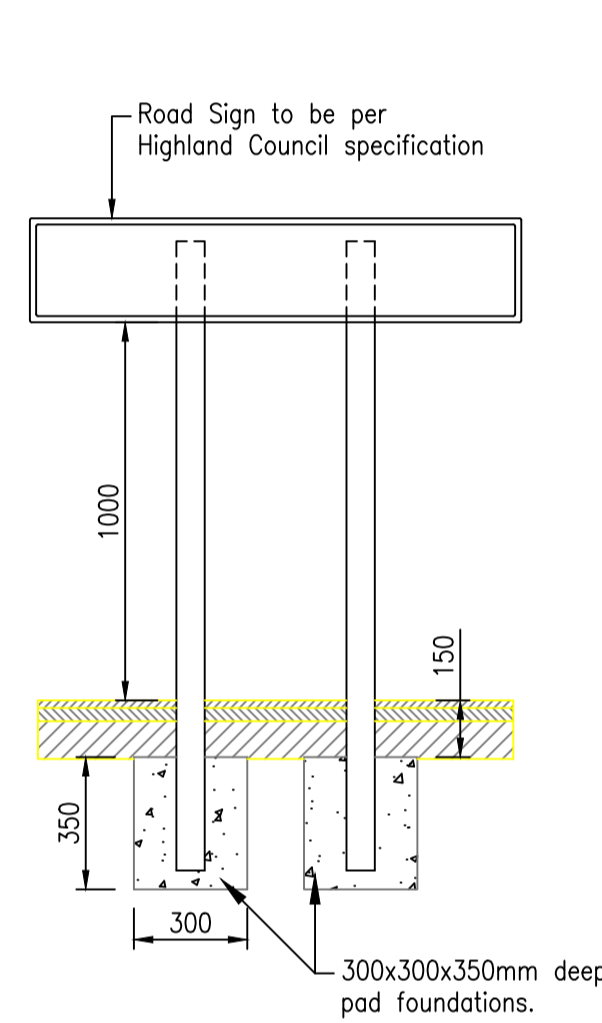

Typical Road Sign Pole and Foundation Detail (Two Pole)

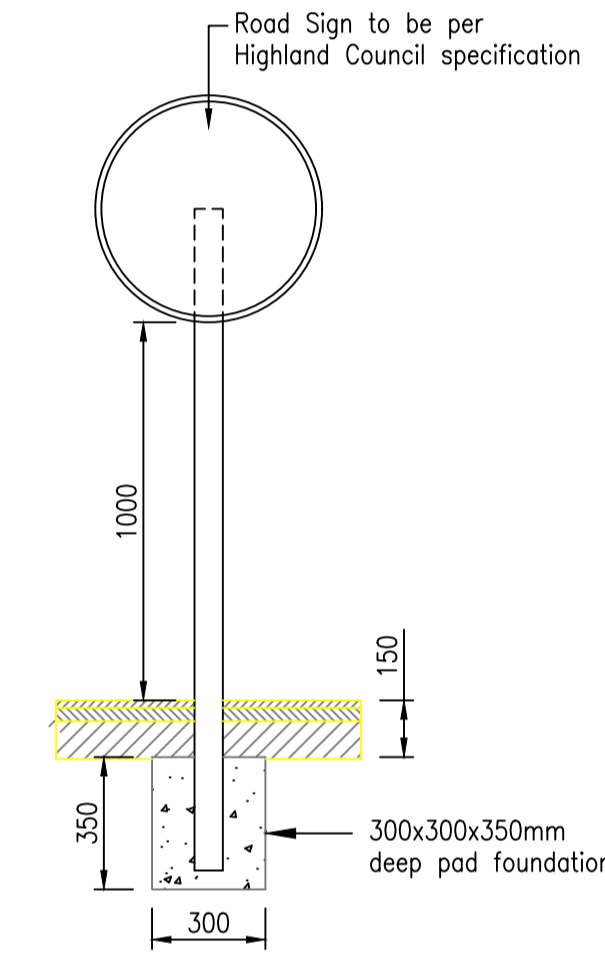

Typical Road Sign Pole and Foundation Detail (Single Pole)

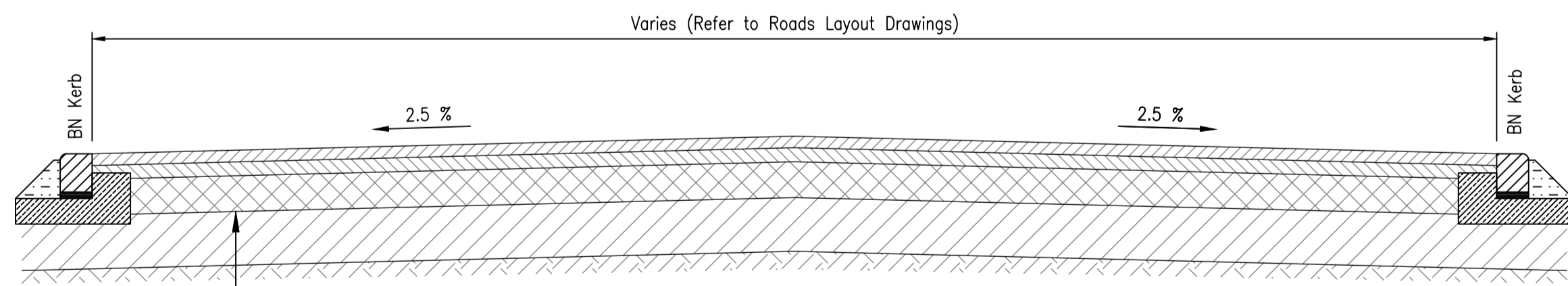

Typical Pavement Construction Detail (3% CBR)

Capping and Sub-Base thickness Based on Highland Council Guidance		
CBR	Capping Thickness	Sub-Base Thickness
2.5%	250mm	350mm
5%	210mm	240mm
10%	180mm	180mm
15%	-	200mm

- Notes:
- 450mm min cover of approved material required on frost susceptible road formation.
  - The contractor shall be responsible for identifying any soft spots within the final excavated areas. Proof rolling shall be undertaken as defined in SHW Clause 616. Where soft spots are encountered, the contractor shall inform the Engineer. The contractor shall remove all soft spots to below formation level and replace them with well compacted imported granular fill to the satisfaction of the engineer.

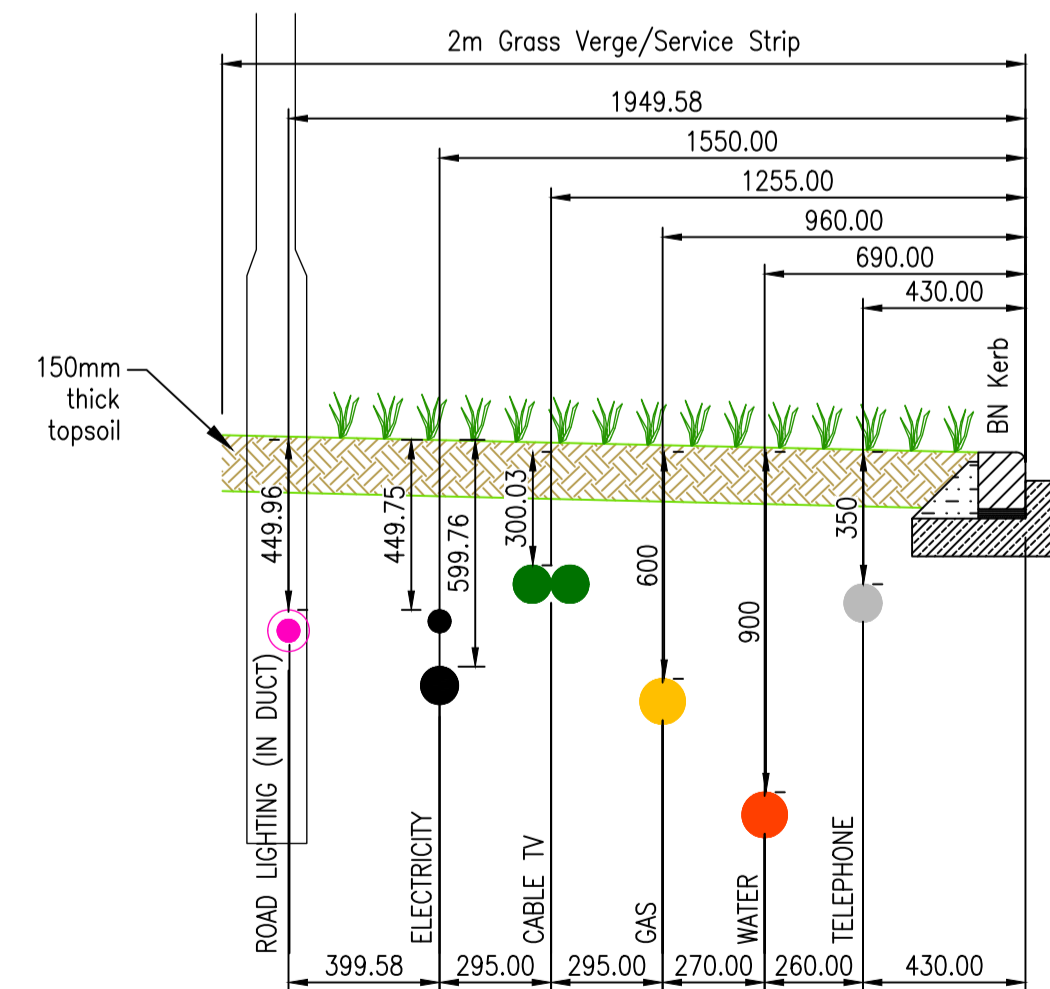

Typical Service Strip Detail

Do not scale from this drawing.

**SAFETY HEALTH AND ENVIRONMENTAL INFORMATION**

IN ADDITION TO THE HAZARD/RISKS NORMALLY ASSOCIATED WITH THE TYPES OF WORK DETAILED ON THIS DRAWING, NOTE THE FOLLOWING RISKS AND INFORMATION.

RISKS LISTED HERE ARE NOT EXHAUSTIVE. REFER TO DESIGN ASSESSMENT FORM NO. DAF01

**CONSTRUCTION:**  
LIVE PRIMARY ROUTE TRAFFIC (B9039). UTILITIES TO BE DIVERTED/PROTECTED

**DEMOLITION:**  
NONE THAT WOULD NOT BE APPARENT TO A COMPETENT CONTRACTOR

FOR INFORMATION RELATING TO USE, CLEANING AND MAINTENANCE SEE THE HEALTH AND SAFETY FILE.

IT IS ASSUMED THAT ALL WORKS WILL BE CARRIED OUT BY A COMPETENT CONTRACTOR WORKING, WHERE APPROPRIATE, TO AN APPROVED METHOD STATEMENT.

**Notes:**

- Do not scale from this drawing, only written dimensions are to be used.
- This drawing is to be read in conjunction with all architectural and engineering drawings, details and specifications.
- All work to comply with Highland Council's Roads and Transport Guidelines for New Developments.
- Road signs and markings to be in accordance with the Traffic Signs Regulations And General Directions 2016.
- Any discrepancies should be reported to the engineer immediately so clarification can be sought.
- For clarity this drawing should only be printed and read in colour.

Rev.	Date	Description	Drawn	Chkd.	Appd.
B	23.10.23	Drawing title updated. Half battered kerb and B9039 verge details removed	HF	AH	AKF
A	22.08.23	Sign height dimensions added. Road sign pole and foundation details added.	HF	AH	AKF

Client: **FAIRHURST** Castle Stuart Golf LLP

Elvie House  
Beechwood Business Park  
WICKNESS  
IV2 3BW

Tel: 01463 724 544  
Fax: 0844 381 4412

Project Title:  
**Cabot Highlands**

Drawing Title:  
**Upgraded Access Typical Road Construction Details**

Scale at A1:		Status:	
As Shown		Road Construction Consent	
Drawn: HF	Checked: AH	Approved: AKF	
Date: 12/07/2023	Date: 21/09/2023	Date: 21/09/2023	
Drawing No.: 154163-PC-1120		Revision:	B