

APPLICATION FOR NON-MATERIAL AMENDMENT
Planning approval ref: DC/23/132396
AS APPROVED GROUND FLOOR PLAN
AS APPROVED ROOF PLAN
AS APPROVED FRONT ELEVATION
AS APPROVED REAR ELEVATION
011

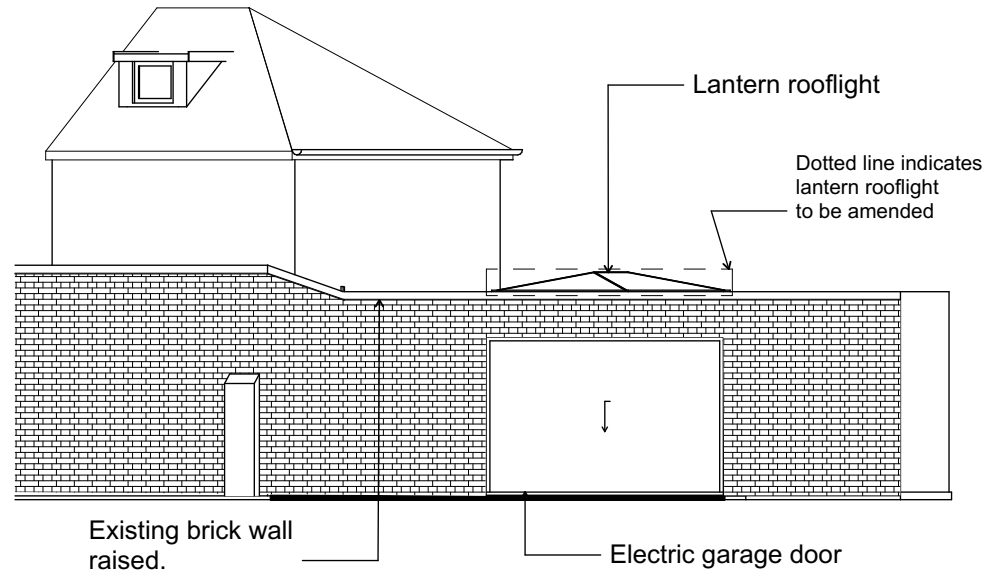

3 Proposed Front Elevation 1:1004

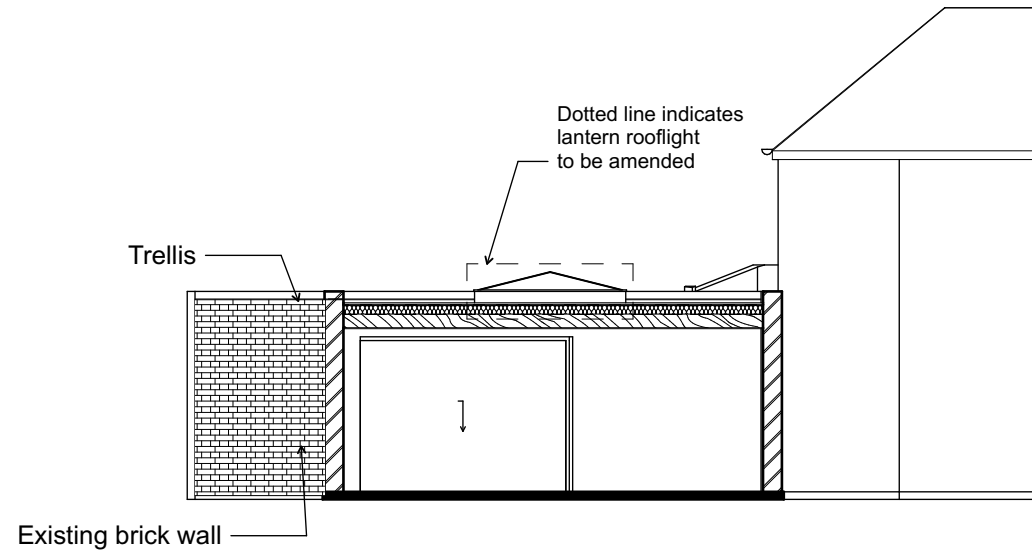

Proposed Rear Elevation 1:100

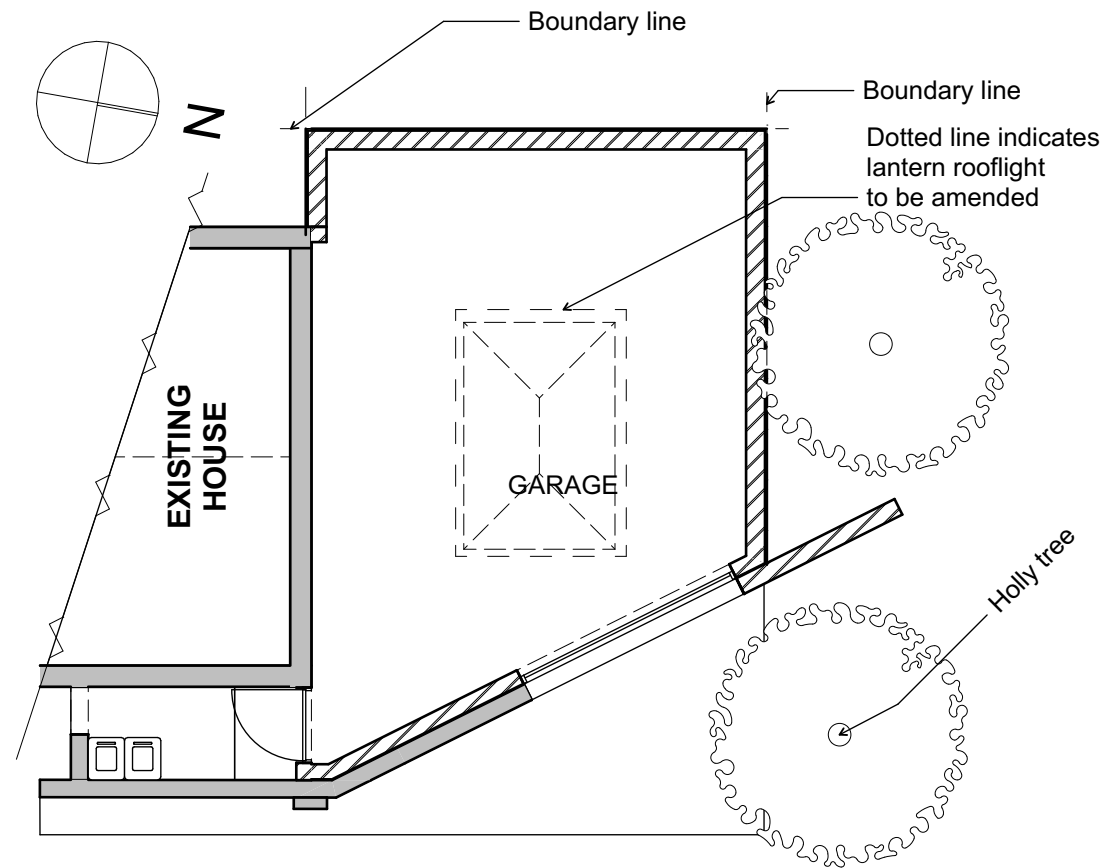

1 GF-Ground Floor 1:100 2

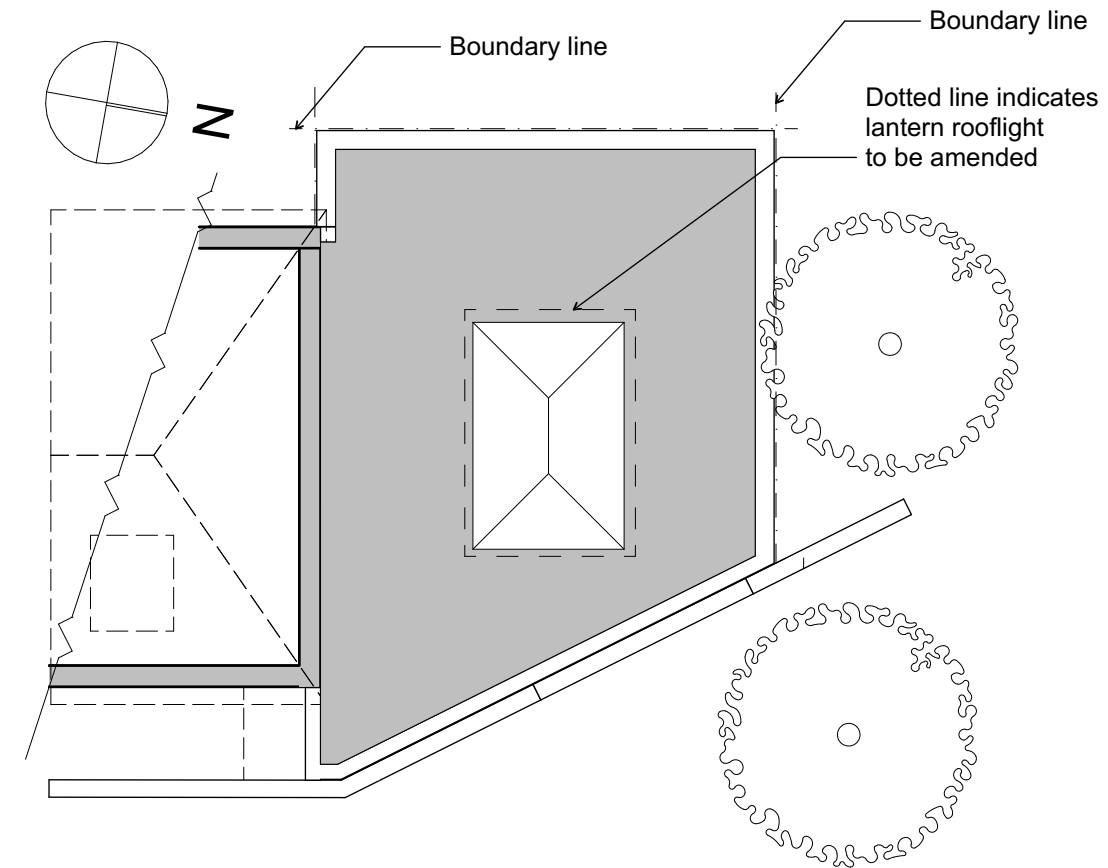

01-First Floor 1:100

DESIGN HOME PLAN

M: 07792781971
 e-mail: designhomeplan23@gmail.com
 Website: designhomeplan.co.uk

Client: Cartwright

Site Location
 23A Lee Terrace
 Blackheath SE3 9TE

Dwg Desc:
 PROPOSED GROUND FLOOR PLAN
 PROPOSED ROOF PLAN
 PROPOSED FRONT ELEVATION
 PROPOSED REAR ELEVATION

Job Ref	1023
Dwg No	011
Scale	1:100 @ A3
Drawn By	IT
Date	June 2023

Do not Scale from this drawing all dimensions to be checked on site before work commences. Copyright Reserved