

Full Planning & Listed Building Consent Application for:

**25 Fairfield Square
Moravian Settlement
Droylsden
Manchester
M43 6AD**

December 2023

Replacement of the damaged first floor timber sash window to a treated timber unit to match.

architecture:m

a: Moravian College
14 Fairfield Square
Droylsden
Manchester
M43 6AD

t: +44 [0] 161 370 6166

e: mail@architecturem.co.uk

w: www.architecturem.co.uk

Contents

3	1.0	Introduction
5	2.0	Planning Policy
8	3.0	Site Background
13	4.0	Context Analysis
18	5.0	Schedule of Works
19	6.0	Heritage Significance
21	7.0	Site Location
23	8.0	Drawings
32	9.0	Design & Access Statement
36	10.0	Conclusion

This supporting appendix document is submitted by architecture:m in support of a Full Planning & Listed Building Consent Application for the replacement of a non-original first floor sash window at the Grade II* listed property of 25 Fairfield Square, Moravian Settlement, Droylsden, Manchester.

This document contains the following supporting information for your consideration:

- Drawings; illustrating the existing and proposed details of the development.
- Photography; illustrating the existing implications on the proposed details of the development.
- Design and Access Statement; an assessment of the design evolution and principles of the development.

Proposal

The scope of works comprises the replacement of a none original timber sash window at a Grade II* listed dwelling with a uPVC sash window to match. Replacement of the window is to be carried out in accordance with PAS 23, BS6375 and PAS 24.

1.1 Planning Statement

Architecture:m's approach to the design of proposals follows guidance and best practice for developing a sensitive and sympathetic scheme within the context of an existing Grade II* listed building. This involves establishing an understanding of the building's evolution and the impact that it has on the local environment and neighbouring conservation assets. This will set the parameters for the formulation of options that can fully explore the ways that the repair works to the existing property can be achieved.

This report is the starting point in the formulation of designs for future changes to the building. It examines the potential issues and architectural development of the building to identify avenues of the existing assets whilst giving a preliminary insight into the design options that are available in order to achieve a robust strategy that retains the historic values of the building.

The proposal is to make relevant minor repairs to the dwelling, ensuring that the architectural character of the building is well retained and ensuring that the building is watertight, well insulated and secure. The proposed works intends to avoid harming the architectural features of the building whilst ensuring that the structure is fit for purpose for future generations.

2.0 National Planning Policy Framework

The heritage planning policy of relevance to the proposed scheme, and which provides the context for its assessment, is set out within national and local planning policy guidance.

National Planning Policy Guidance

Town and Country Planning Act 1990

Section 38(6) of the Planning Act states that the determination of planning applications must be made in accordance with the Development Plan, unless other material considerations indicate otherwise. This establishes the Development Plan as the primary decision making document when considering planning applications.

In this instance the development plan currently comprises the Manchester Core Strategy Development Plan and the saved policies of the Unitary Development Plan for Manchester. A relevant supplementary planning guidance document is the Guide to Development in Manchester Supplementary Planning Document. The relevant provisions of these documents are discussed below.

Planning (Listed Buildings and Conservation Areas) Act 1990

The application site includes 25 Fairfield Square which is Grade II* listed and therefore affect the application property. Once a building is listed, Section 7 of the Planning (Listed Buildings and Conservation Areas) Act provides that consent is required for any works which may affect its special interest.

Section 66 of the Planning [Listed Buildings and Conservation Areas] Act 1990) advises that in considering whether to grant planning permission for development which affects a listed building or its setting, the local planning authority shall have special regard to the desirability of preserving the building or its setting or any features of special architectural or historic interest which it possesses.

The proposed scheme involves direct works to the exterior fenestration and interior arrangement of the listed building which will need to be considered by Manchester City Council. The local planning authority will also need to consider the potential indirect impact of the development on the setting of the building and upon the character and appearance of the Smithfield Conservation Area. Section 7 of this report considers these matters.

National Planning Policy Framework (NPPF)

Detailed guidance about the legislation is given in National Planning Policy Framework (NPPF), which was published on 27th March 2012 and sets out the Government's planning policies regarding the conservation of the historic environment. The NPPF is a key part of reforms to make the planning system less complex and more accessible; to protect the environment; and to promote sustainable growth. It replaces previous national planning policy guidance and is a material consideration in planning decisions.

NPPF places great emphasis on the role of decision makers to promote sustainable development. Paragraph 8 advises that sustainable development has three dimensions: 'economic, social and environmental'

In relation to determining planning applications, the NPPF sets out a presumption in favour of sustainable development which should be seen as a golden thread running through planning decision making. Unless material considerations indicate otherwise, local planning authorities are urged to 'approve development proposals that accord with the development plan without delay'. The NPPF (paragraph 11) is clear that 'local planning authorities should approach decision taking in a positive way to foster the delivery of sustainable development'.

Section 16 of the NPPF deals with conserving and enhancing the historic environment. Paragraph 189 advises that 'In determining applications, local planning authorities should require an applicant to describe the significance of any heritage assets affected, including any contribution made by their setting'. 'Significance' is defined by Annex 2: 'Glossary of NPPF' as: 'The value of a heritage asset to this and future generations because of its heritage interest. The interest may be archaeological, architectural, artistic or historic. Significance derives not only from a heritage asset's physical presence, but also from its setting'.

'Setting of a heritage asset' is also defined by Annex 2 as: 'The surroundings in which a heritage asset is experienced. Its extent is not fixed and may change as the asset and its surroundings evolve. Elements of a setting may make a positive or negative contribution to the significance of an asset, may affect the ability to appreciate that significance or may be neutral'.

Paragraph 190 of the NPPF advises that: 'Local planning authorities should identify and assess the particular significance of any heritage asset that may be affected by a proposal (including by development affecting the setting of a heritage asset) taking account of the available evidence and any necessary expertise. They should take this into account when considering the impact of a proposal on a heritage asset, to avoid or minimise any conflict between the heritage asset's conservation and any aspect of the proposal'.

Plans should set out a positive strategy for the conservation and enjoyment of the historic environment, including heritage assets most at risk through neglect, decay or other threats. This strategy should take into account:

- 'the desirability of sustaining and enhancing the significance of heritage assets and putting them to viable uses consistent with their conservation;
- the positive contribution that conservation of heritage assets can make to sustainable communities including their economic vitality;

Paragraph 193 of the NPPF advises that 'When considering the impact of a proposed development on the significance of a designated heritage asset, great weight should be given to the asset's conservation (and the more important the asset, the greater the weight should be). This is irrespective of whether any potential harm amounts to substantial harm, total loss or less than substantial harm to its significance.'

More importantly, paragraph 194 of the NPPF states: Any harm to, or loss of, the significance of a designated heritage asset (from its alteration or destruction, or from development within its setting), should require clear and convincing justification. Substantial harm to or loss of:

- grade II listed buildings, or grade II registered parks or gardens, should be exceptional;
- assets of the highest significance, notably scheduled monuments, protected wreck sites, registered battlefields, grade I and II* listed buildings, grade I and II* registered parks and gardens, and World Heritage Sites, should be wholly exceptional.

Paragraph 195 advises that: 'Where a proposed development will lead to substantial harm to (or total loss of significance of) a designated heritage asset, local planning authorities should refuse consent, unless it can be demonstrated that the substantial harm or total loss is necessary to achieve substantial public benefits that outweigh that harm or loss'.

2.1 National Planning Policy Framework

Paragraph 196 advises that ‘Where a development proposal.

will lead to less than substantial harm to the significance of a designated heritage asset, this harm should be weighed against the public benefits of the proposal including, where appropriate, securing its optimum viable use’.

National Planning Practice Guidance (NPPG)

With regard to assessing substantial harm, National Planning Practice Guidance advises: ‘Whether a proposal causes substantial harm will be a judgment for the decision taker, having regard to the circumstances of the case and the policy in the National Planning Policy Framework. In general terms, substantial harm is a high test, so it may not arise in many cases. For example, in determining whether works to a listed building constitute substantial harm. An important consideration would be whether the adverse impact seriously affects a key element of its special architectural or historic interest. It is the degree of harm to the asset’s significance rather than the scale of the development that is to be assessed. The harm may arise from works to the asset or from development within its setting.’ (Paragraph: 017 Reference ID: 18a-017-20140306).

Historic England Guidance

Historic England has published guidance to assist with the management of the historic environment. This assessment has been prepared having regard to the following Historic England Guidance.

Historic England Advice Note 2: Making Changes to Heritage Assets

Published in February 2016, this advice note illustrates the application of the policies set out in the NPPF in determining applications for planning permission and listed building consent.

Historic England Advice Note 3: The Setting of Heritage Assets

Published in March 2015, this document provides guidance for managing change within the setting of heritage assets, including historic buildings, sites, areas and landscapes. Historic England ‘Seeing the History in the View’

Published in May 2011, this document provides guidance

for initial baseline analysis of the heritage significance in any selected view, followed by assessment of the impact on that significance of particular development proposals. The guidance explains Historic England’s own approach to views assessment and is intended to be of use to local planning authorities, professionals and developers as well as the interested public.

Historic England Advice Note 14: Energy Efficiency and Traditional Homes

Published in July 2020, this advice note considers energy efficiency improvements to those traditional homes which are described as heritage assets within the planning system.

C1 Townscape and Urban Form

In considering proposals for built development, the Council will expect the distinct settlement pattern, open space features, topography, townscape and landscape character of specific areas of the Borough to be understood, and the nature of the surrounding fabric to be respected. The relationship between buildings and their setting should be given particular attention in the design of any proposal for development.

Urban design frameworks will be produced for particular areas and corridors in the Borough, as supplementary planning guidance, setting out fundamental principles which should be followed and from which detailed design may be interpreted.

The Council will establish a strategy to secure the retention and enhancement of landmark buildings which form a distinctive element of the local skyline or townscape, and which represent a unique part of the heritage of the area. Re-use and conversion of such buildings which become redundant will be permitted, subject to other relevant policies.

The character of Tameside's towns and villages was mostly established during their rapid growth in the 19th Century. They developed different characters due to topography, street pattern, available materials, industrial role etc, yet with common threads running through most areas, including market squares, groups of civic buildings, cotton mills, canals, turnpikes, small terraced houses and intimate urban spaces. Most settlements also came to have important landmarks or views. Although some of the traditional character has been diluted by the more recent influx of non local materials and styles, the Borough still possesses a diversity of townscape which reflects its historical pattern of development. Characteristic urban form and townscape merit respect and enhancement in many parts of the Borough, and not just where designated as Conservation Areas.

This policy is intended to ensure that adequate emphasis is placed on design considerations in the preparation of proposals and the application of development control procedures. Needless damage to the character and appearance of the area and its buildings can be caused by careless or unsympathetic design. The urban design frameworks will be prepared progressively, to provide

guidance appropriate to areas of particular character. High standards of design are important even where there is no compelling need to respect established patterns of development, if the built environment as a whole is to be upgraded. The strategy to be established should help to stem the further loss of landmark buildings by encouraging a flexible range of alternative uses and by recognising their historic, social and architectural significance to the area.

Supplementary Planning Guidance to be produced under this and other relevant policies will address, among other things, the circumstances in which any development control standards might be relaxed in order to facilitate the retention and enhancement of landmark buildings.

C2 Conservation Areas

The character and appearance of the Borough's Conservation Areas, including any further changes to areas which may be declared during the life of the plan, will be preserved or enhanced through the control of development, the promotion of improvement measures, or both.

There is widespread recognition of the importance of preserving and enhancing groups of buildings and areas of towns and villages which have a special architectural, historic, traditional or other distinctive or rare character or setting to them. Public support has grown for protecting and where necessary restoring or adapting such groups or areas. There are currently nine Conservation Areas in Tameside, and the boundaries of these are shown on the proposals map. As well as providing vital additional controls on development, there is a duty on local authorities to formulate and publish proposals for the preservation and enhancement of their Conservation Areas. The views of the local community, property owners and developers are extremely important to this process. The practical ability to undertake such schemes ultimately will be determined by the availability of resources. Conservation character appraisals will be carried out for each of the Conservation Areas and will form the basis for supplementary planning guidance.

C4 Control of Development in or adjoining Conservation Areas

When considering proposals for development in or adjoining Conservation Areas, including advertisements and the alteration, extension or conversion of existing buildings

within Conservation Areas, the Council will have regard to the desirability of preserving or enhancing the character or appearance of the area, and to the need to ensure that the proposals make a positive contribution to the context in which they are set.

The purpose of this policy is to preserve and enhance the fabric, character and appearance of designated areas, through detailed consideration of development proposals and the likely impact they will have on the protected buildings and their setting. It covers both new development and changes to existing buildings. It is equally important to ensure that Conservation Areas or their setting are not adversely affected by discordant development nearby. It is also recognised that new development and alterations to existing buildings can sometimes be used as an opportunity to significantly improve the overall quality of a Conservation Area, such as by replacing unattractive existing elements. The matters that may require particular attention will be set out in supplementary planning guidance.

C5 Alternative Uses, Alterations and Additions for Listed Buildings

Whilst continuation of the use for which the building was designed is most desirable, the Council will permit alternatives uses for Listed Buildings where evidence demonstrates that the existing or original use is unlikely to support the maintenance and preservation of the building.

The Council will require that proposed new uses, or other alterations and additions to Listed Buildings, should not adversely affect the essential character of the building, should be in keeping with its architectural style and features, and should harmonise with its surroundings. The effect of the proposals on any protected species which may be using the Listed Building should also be taken into account.

Such development must be of a high standard of design. The external appearance, design and materials will be expected to match as near as possible those of the existing building and, where appropriate, new internal features should also harmonise with the existing.

Extensions and additions should be secondary in scale, design and location to the principal building and standard

solutions or modern features which fail to relate to the character of the building will not be permitted.

The listing by the Government of buildings of architectural or historic interest provides a comprehensive set of controls for the protection of the nation's architectural heritage. There were 312 listed "schedules" in Tameside in September 2003, with some of these containing more than one building such as a row of cottages. If they are to continue to be of the greatest benefit listed buildings need to be maintained in good condition, and the basic responsibility for upkeep rests with the owner. The Council recognises however that due to the particular characteristics of a listed building, it may sometimes be difficult to continue the original or existing use. This could result in the building being left disused and decaying, or threatened with demolition and redevelopment, which can often happen for instance with mills or religious buildings which become redundant. Whilst other policies in the plan will clearly have to be taken into account, it may be better for the survival of the listed building if a viable new use can take over. It is important however that the new use does not damage the qualities of the building which make it special.

Alterations and additions to listed buildings, perhaps involving demolition of part of the original structure, may sometimes be proposed. The reasons for the work may well be sound and the investment welcome for the confidence it shows in the continued usefulness of the building. However, it is very important that damage should not be done to the character of a building through inappropriate or unsympathetic design or by use of unsuitable materials. Quite small scale or detailed matters can often make a significant impact and it will normally be worthwhile to seek advice from the Council or from other professionals in this field. Because of their age and location listed buildings may sometimes support species which are protected by law, such as bats and some birds, and these could be adversely affected by alterations or extensions if not taken into account.

C6 Setting of Listed Buildings

New development, including any proposed as a result of a new use for a Listed Building, which fails to preserve, or detracts from, the setting of a Listed Building or structure will not be permitted.

The setting of a listed building and its surroundings will in

most instances have some bearing on its special character. The carrying out of development in the vicinity of the building could therefore be expected to have an impact on that character, which might be quite severe for instance if conflicting or inharmonious elements were introduced at close quarters or in an important line of sight. This policy recognises the importance of safeguarding the overall character or setting of listed buildings and indicates the Council's intention to closely scrutinise and assess the impact of development proposals in their vicinity.

C7 Enabling Development for Conservation of Heritage Assets

Development which is proposed so as to enable the restoration of Scheduled Ancient Monuments, Listed Buildings, Conservation Areas or Registered Parks and Gardens (heritage assets) will only be permitted if each of the following criteria are met:

a) the development will not material detract from the archaeological, architectural, historic or landscape interest of the heritage asset, or materially harm its setting, and

b) the proposal avoids a fragmentation of management which may have adverse effects upon the heritage asset, and

c) the development will secure the long term future of the heritage asset, and where applicable, its continued use for a sympathetic purpose, and

d) the problem arises from the inherent needs of the heritage asset, rather the circumstances of the present owner or the purchase price paid, and

e) the development is the only viable source of adequate financial assistance, and

f) the amount of enabling development is the minimum required to secure the future of the heritage asset, and its form minimises disbenefits, and

g) the value or benefit of the survival or enhancement of the heritage asset outweighs the long term disbenefits to the community of providing the enabling development.

Some listed buildings and other heritage assets are either

neglected, disused, decaying or even derelict, typically resulting from them being no longer needed for their original purpose and more difficult to convert to other uses. These can include certain large and prominent buildings which are key features of local townscape. It is important that their value and contribution to the built environment is recognised and that their condition and appearance are protected and enhanced. The most serious cases are included on a "Buildings at Risk" register and continued efforts are made by the Council to contain physical deterioration, to bring them back into suitable use and to achieve sensitive restoration, through partnerships and funding mechanisms as appropriate and available. Pressure for "enabling development" may increase in cases where expensive restoration of historic buildings is involved, and needs to be carefully scrutinised. Successful restoration of "Buildings at Risk" should help to increase the attractiveness of the area, stimulate investment and secure regeneration. The criteria listed in this policy are derived from the English Heritage document "Enabling Development and the Conservation of Heritage Assets", published in June 2001, which can be referred to for further guidance on the issues involved.

2.4 Fairfield Conservation Area Appraisal

The following Design Principles have been developed from the findings of the Fairfield Conservation Area Appraisal:

Traditional Buildings

Statutory listed buildings should be retained, sympathetically restored and reused in recognition of their historic, architectural and townscape qualities. Locally listed buildings are major contributors to the character of the Conservation Area. It is recommended that the Council will, as far as possible, resist the loss of any building which is proposed to be included within the developing Local List.

Alterations and extensions to a locally listed building or development affecting their setting, should be designed with particular care. These buildings should be retained, sympathetically restored and enhanced. Empty or under-utilised buildings within the Conservation Area should be sympathetically restored and reused.

Sympathetic, Contextual Design

Any new and/or infill development within or adjacent to the Fairfield Conservation Area must respect the scale, height, massing, alignment and traditional materials used within the Conservation Area. This includes the careful consideration of the design of roof lines, shape, eaves and gable details and the creation of chimney stacks. The Council will insist on high quality schemes which respond positively to the character and setting of the Conservation Area. This extends to garages and ancillary buildings.

The development of hard standing to create parking areas in gardens is to be resisted, as this would have a detrimental effect on the character and appearance of the Conservation Area.

Extensions and alterations to an existing building should be designed to enhance the building. Traditional building material and styles typically found within the building and/or Conservation Area should be incorporated into the overall design. The introduction of dormer windows and roof lights in unlisted buildings should be avoided unless modestly sized and on rear elevations of the building.

The use of brick as the predominant building material is integral to the areas character and appearance; therefore exterior rendering of walls and painting of masonry should be avoided.

A Design and Access Statement will be expected to accompany any future planning application affecting a heritage asset. Applicants will be required to describe the significance of any heritage asset affected including any contribution made by their setting in order to justify design decisions, development proposals and/or alterations.

Demolition

If approval for demolition is granted by the local planning authority, materials and features of interest such as name and date stones salvaged from the cleared site, should be incorporated into new development where appropriate.

Repairs and Maintenance

Regular maintenance of historic buildings will avoid future costly repairs which may be required to rescue buildings from significant deterioration and possible dereliction.

When undertaking maintenance and repair to buildings within or adjacent to the conservation area regard should be had for the desirability of preserving and enhancing the character and appearance of the buildings and the need to make a positive contribution to the context in which they are set. Original material such as brick and Welsh slate should be retained and reused. Where the reuse of original material is not possible, new materials should be sourced to match the original. Traditional construction and repair techniques should be employed.

The presence of unsympathetic replacement windows and doors within traditional buildings detracts from the overall character and appearance of the Conservation Area. Attempts should be made to repair traditional windows and doors in order to conserve the original design and fabric of the buildings and thereby conserve the historic character of the Conservation Area. Timber windows frames and doors should be painted rather than stained. Replacement windows and doors should follow traditional design, using traditional materials and should be set back from the reveal. Chimney stacks and their pots should be retained wherever possible. Repairs should be carried out in matching natural stone or brick as appropriate.

- No.2 (Lockside), Buckley Street, Grade II
- Lockside Cottage, Buckley Street, Grade II
- Former Packet Boat House, adjacent to Bridge No.16, Manchester & Ashton under Lyne Canal, Grade II
- Former Tollhouse, adjacent to Fairfield Top Lock, Manchester & Ashton under Lyne Canal, Grade II
- Bridge No.16, Manchester & Ashton under Lyne Canal, Grade II
- Lock No.18 (Fairfield Top Lock), Manchester & Ashton under Lyne Canal, Grade II
- Nos. 3, 4 & 5 Fairfield Square, Grade II
- Nos. 6a, 6 & 6b Fairfield Square, Grade II
- No. 7 Fairfield Square, Grade II
- No. 8 Fairfield Square, Grade II
- No. 9 Fairfield Square, Grade II
- Nos. 10 & 10a Fairfield Square, Grade II
- Nos. 11 & 12 Fairfield Square, Grade II
- No. 11a Fairfield Square, Grade II
- Nos. 13, 13a & 14 (Former Moravian College) Fairfield Square, Grade II
- Nos. 15, 16 & 17 Fairfield Square, Grade II
- No. 18 Fairfield Square, Grade II
- No. 19 Fairfield Square, Grade II
- Nos. 20, 21, 23 & 23a Fairfield Square, Grade II*
- **Nos. 24, 25, 26 & 27 Fairfield Square, Grade II**
- Nos. 15a, 28, 30 & Fairfield Moravian Church, Fairfield Square, Grade II*
- Fairfield High School (east block only), Fairfield Avenue, Grade II
- Nos. 31b, 31c & 32 Fairfield Square, Grade II
- Nos. 32a & 32b Fairfield Square, Grade II
- Nos. 33, 34, 35 & 36 Fairfield Square, Grade II
- No. 37 Fairfield Square, Grade II
- Nos. 37a, 38, 39 40 & 40b Fairfield Square, Grade II
- Nos. 41 (The Orchards) & 42 Fairfield Square, Grade II
- Nos. 43, 44 & 45 Fairfield Square, Grade II
- No. 46 Fairfield Square, Grade II
- Nos. 47-48 Fairfield Square, Grade II
- No.49 Fairfield Square, Grade II
- Sundial in Burial Ground, South of Church, Fairfield Square, Grade II

3.0 Listed Properties & Conservation Area

The landscape around the immediate context of the Moravian Settlement at the time of its construction was covered mostly with agricultural fields and greenbelt land. The Moravian Settlement in Fairfield, Droylsden was the most prominent feature within the landscape having being built towards the later period of the 18th Century, making it one of the oldest remaining settlements in Greater Manchester.

Today, the Moravian Settlement sits at the heart of the Fairfield Conservation Area, designated by Lancashire Council, in 1971 and extended in 1975 to include the Ashton Canal and land to the east of the settlement. The area is characterised as by a broad mix of uses however, the building stock is primarily made up of residential dwellings. Of the 33 listed buildings, 27 are located with the settlement itself resulting in Fairfield having the most listed buildings of any conservation area in Tameside. The settlement also has a number of listed grounds including the Burial Grounds and the Orchards.

The continual residential accommodation as conducted by the Moravian Church has been of great importance in the retention of the historical and cultural significance of the area throughout the generations of use.

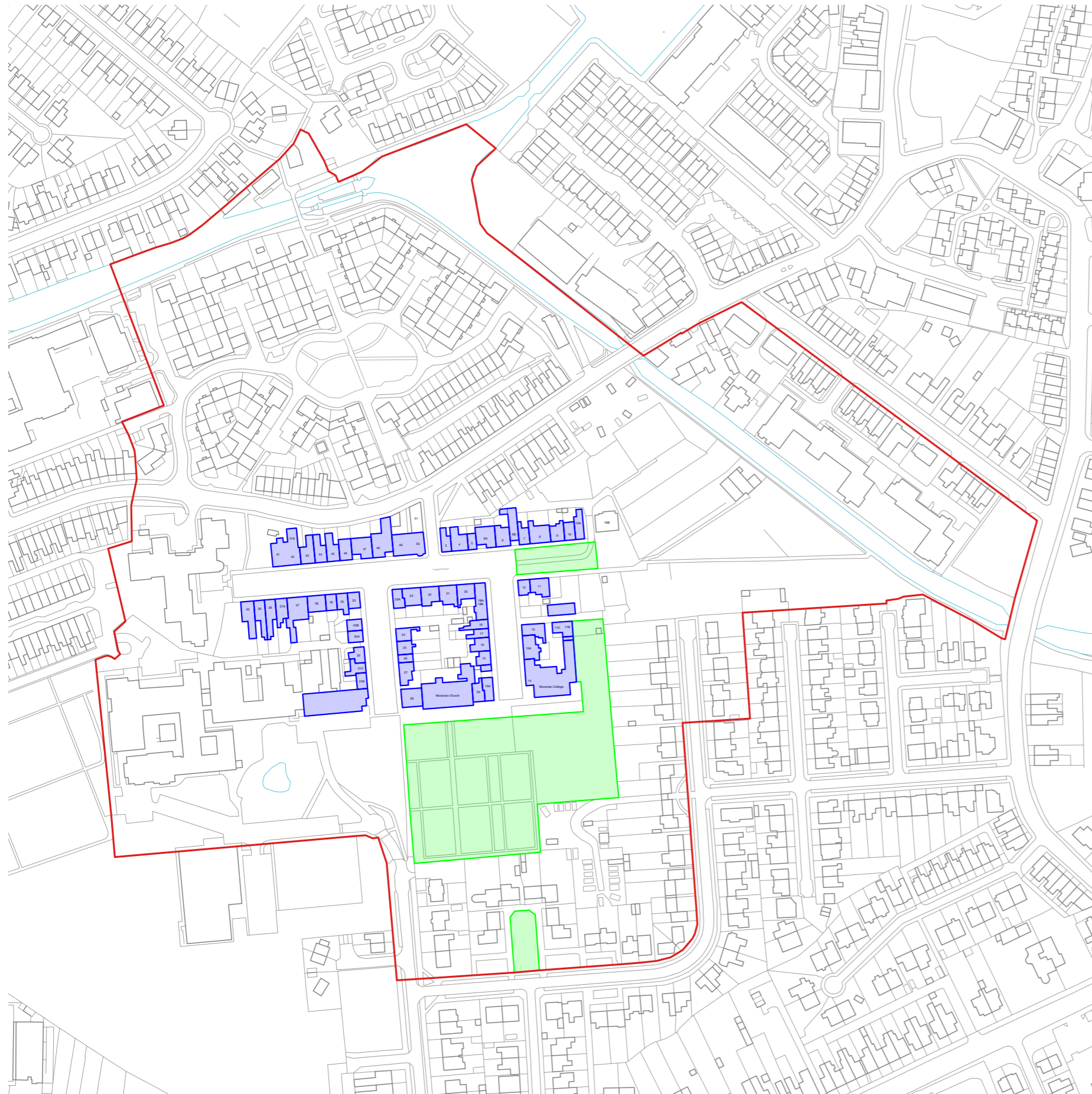

3.1 Historic Analysis

Mid 18th Century

The landscape around the immediate context of the Moravian Settlement at the time of its construction was covered mostly with agricultural fields and greenbelt land. The Moravian Settlement in Fairfield, Droylsden was the most prominent feature within the landscape having being built towards the later period of the 18th Century, making it one of the oldest remaining settlements in Greater Manchester.

Late 18th Century

Towards the latter part of the 19th Century, more residential plots began to populate the surrounding landscape with red brick cottages and manor houses lining Manchester Road, a now distinct road network that connected Manchester City Centre to Ashton Under-Lyne.

Early 19th Century

The lack in development of the area between the period of 1894 and 1915 is evident of the struggle during the era of the first world war and the post economic depression which ensued. As such, very few houses were constructed at this time.

Mid 19th Century

The pre war era saw the development of the area further. In the mid to late 1930s, a housing boom was in full swing following the end of the great depression and this explosion led to huge changes in the way houses were being designed, built and located, evidential of the success that Manchester saw during the industrial revolution. The 19th century terraced houses remain within the area however, a flurry of new development has taken place on existing brownfield sites including the construction of new build dwellings and apartments.



3.2 Local Planning Development

The following information covers the recent planning development that has taken place within the local vicinity of the study site. All developments listed date back to no more than 3 years and falls within grid reference SJ9097, a 2km square area that is covered by both the Moravian Settlement and Fairfield Conservation Area.

20/00105/REM - Former Robertson's Jam Factory

Golden Shred Works, Williamson Lane, Droylsden, M43 6SS

Application for reserved matters (the scale, layout, landscaping and appearance of the development) for a residential development of 338 dwellings on the site.

20/00129/FUL - Former Site Of St Anne's Nursery

Manchester Road, Audenshaw, Manchester, M34 5PZ

Redevelopment of land to support 16 houses and 18 apartments including associated works.

20/01116/FUL - Former A Plant Hire Site

Fairfield Road. Droylsden, Tameside, M43 6AX

Full Planning Application for erection of 62 dwellings with associated works including car parking, access road and landscaping

126674/FO/2020 - Land At Edge Lane

Manchester, M11 1DG

Erection of 168 two and three storey dwellinghouses and 48 apartments within 3 x three storey buildings to form 216 dwellings in total with associated car parking, boundary treatment, landscaping and other associated works

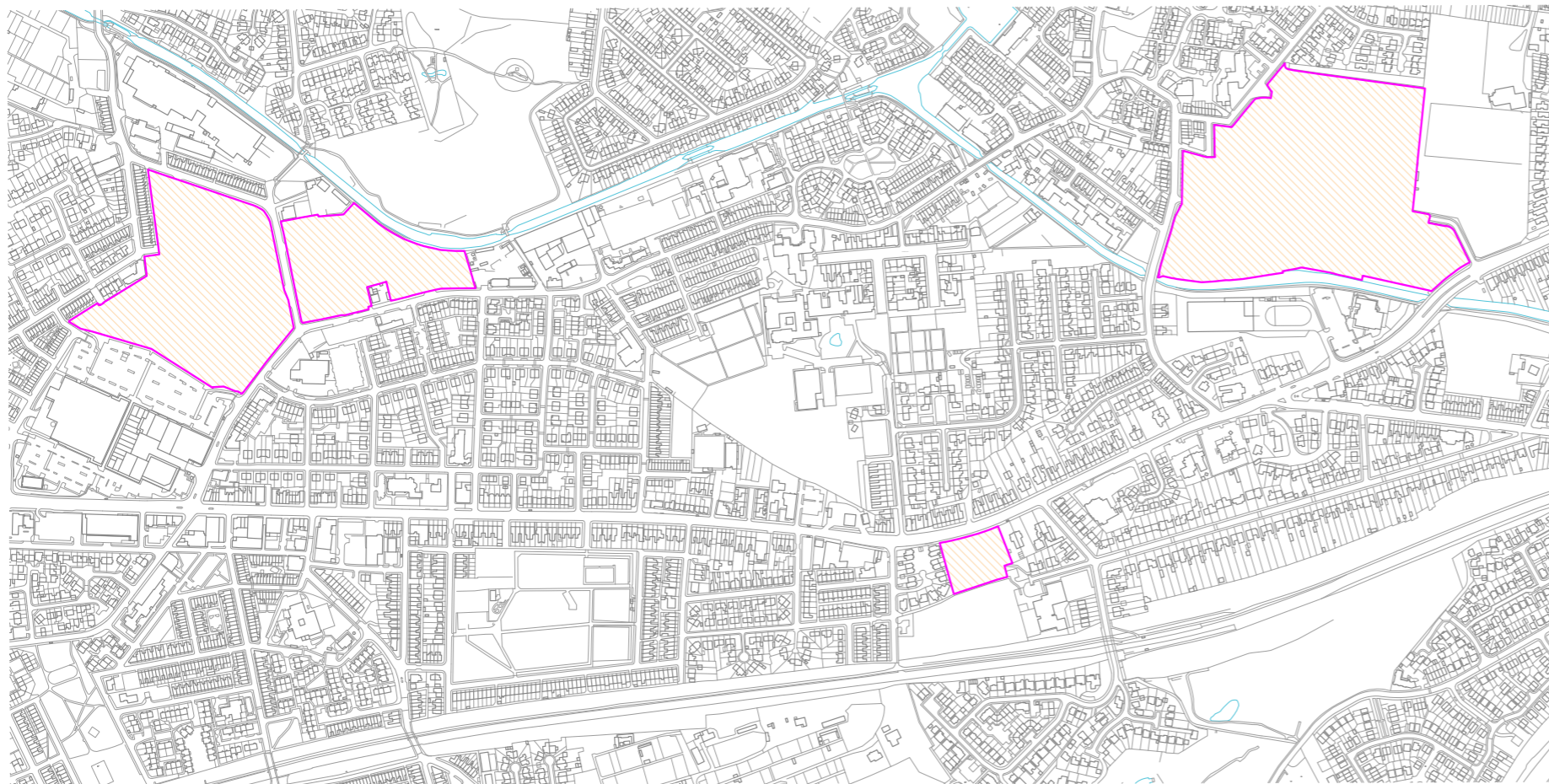

4.0 Site Context

Aerial top down view of the property and its associated site boundary



LEGEND

 Site Boundary

Map not to scale

4.0 Site Context

Aerial view of the Brethren Street front elevation



LEGEND

 Site Boundary

Map not to scale

4.0 Site Context

Aerial view of the Brethren Street front elevation



LEGEND

 Site Boundary

Map not to scale

4.0 Site Context

Aerial view of the rear elevation and garden



LEGEND

 Site Boundary

Map not to scale

4.0 Site Context

Aerial view of the rear elevation and garden



LEGEND

 Site Boundary

Map not to scale

5.0 Schedule of Works

The following statements set out the schedule for the replacement of the first floor sash window at 25 Fairfield Square, Moravian Settlement.

Extent of External Repair & Refurbishment

1. Replace existing timber sash window with a new uPVC unit to match appearance and colour.
2. Retain historic ironmongery and reuse where appropriate.
3. Replace damaged/lost historic ironmongery with like for like heritage replacements.
4. Repair and make good external brick aperture where damage has occurred previously.
5. Paint external stone ledge to match original colour.

Extent of Internal Repair & Refurbishment

1. Repair internal timber frame, ledge and cornicing where damage has occurred.
2. Paint internal timber frame, ledge and cornicing in white.

General Requirements

The following matters need to be considered;

- The need to provide a weather proof solution
- The need to provide natural light and ventilation;
- Design for safety in use;
- Means of escape in case of fire;
- Security against unauthorised entry;
- Design for safety when cleaning;
- Maintenance

Security and Performance

The performance characteristics of external windows and doors are covered by European Standard EN 14351. The Standard identifies performance characteristics that are applicable to windows and doors and it identifies the test methods that should be used to establish these characteristics.

Vulnerable windows should be manufactured to enhanced security standards that meet the requirements of BS EN 1627 – 30 or PAS 24:2012. The vulnerability of windows and doors should be determined by a site risk assessment carried out by a competent person. Generally, windows at ground floor or basement level and those on first floor that are easily accessible are considered to be vulnerable.

6.0 Heritage Significance

Aspect of Significance/Description	Condition and Proposed Alteration	Significance and reason	Justification for Change	Impact Assessment
Proposed Works to the Dwelling				
<p>The structure is an example of a mid-late 18th Century Georgian Era town house within the context of the Droylsden Moravian Settlement and is of significant interest</p> <p>The building has undergone extensive internal works over the past decades, most notably, the change to the internal floor layout with adaptations to modernise the dwelling at the turn of the century to include a first floor bathroom and a comprehensive wet heating system with wall mounted radiators. A ground floor utility room was adapted as a later installation during the extensive repair and refurbishment works that took place in the late 20th Century.</p> <p>The fundamental floor arrangement remains mostly as was.</p>	<p>The basic condition of the building is generally satisfactory, however issues persist both internally and externally. The building on the whole is watertight however works to the roof and guttering were undertaken during the turn of the 20th Century, presumably to resolve on going leaks. The first floor window to room 1/4 is in a poor physical state and is at risk of falling out. Such is the extent of damage to the window that continual water ingress has damaged the timber sash boxes, rails and glazing bars beyond any reasonable state of repair. In respect of this, the window is no longer fit for purpose.</p> <p>Collective and individual alterations are required to repair and improve the existing dwelling. Remaining historic features that add heritage value to the building are to be retained throughout.</p>	<p>Evidential, Historical, Aesthetic and Communal value - Medium/High significance.</p> <p>Relatively few examples of Georgian Era buildings remain in Tameside. The Fairfield Moravian Settlement is one of only a few surviving Moravian settlements left in the UK, evident of its cultural and historic significance.</p> <p>Significance of alterations and non superficial interventions that have taken place in the past century due to sustained gradual damage s affected the historical and aesthetical significance of the building in parts.</p>	<p>The much needed intervention to include the replacement of the sash window within room 1/4 will ensure that the appearance of the building is retained and that its historical character is retained as an important example of a Georgian dwelling within the setting of the Moravian Settlement. The proposals include the repair and preservation of the characteristic and structural features that will not adversely affect the Georgian character of the building block.</p>	<p>Low/Beneficial Impact - The proposals preserve the characteristics associated with the historic block of dwellings and their Georgian origins whilst ensuring their longevity for future use. The proposed replacement sash window to room 1/4 present a low level of impact to the character of the dwelling and is further mitigated by its beneficial impact in providing a watertight and draughtproof fixture. The replacement being carried out on a like for like basis will ensure that the overall character of the dwelling and street frontage is not adversely affected.</p>
<p>Significance of the building as part of, and within the context of the Fairfield Conservation Area. The group of associated buildings in the Fairfield Conservation Area help fill in the overall picture of historic development of the dwelling and the Moravian Settlement on the whole.</p> <p>The design of the building, as a two storey dwelling in the Georgian style, is significant as are the later incremental alterations that have subtly adapted the accommodation to suit the aspirations of later generations.</p>	<p>The condition of various features inside and outside the dwelling are generally good and can be retained and repaired where necessary.</p> <p>Collective and individual alterations to the listed building include the general care and maintenance of features that have lost aesthetic value over the years due to gradual damage and air pollutants. Minimal alterations of the original Georgian construction, internal and external to the dwelling are proposed.</p>	<p>Evidential, Historical, Aesthetic and Communal value - High significance</p> <p>The collection of buildings that attribute to the distinctive character of Sisters Street and the Moravian Settlement on the whole add to the historic characteristic of the Fairfield Conservation Area.</p>	<p>Many aspects of significance are preserved with modern additions having a somewhat sympathetic nature to them. The requirement for the modernisation of historic dwellings is justified in response to the aspirations of the future homes standards and living requirements.</p>	<p>Low Impact - The proposals are designed to retain and enhance the existing structures within the block of dwellings through the use of sympathetic approaches and heritage led methods to carry out repairs. Earlier alterations to the dwelling were carried out without much due respect to the historic character of the dwelling, however are considered to be important as they showcase the historic challenges that the building has been subjected to throughout the 19th and 20th Century.</p>
<p>The degree of collective survival of internal and external historic architectural features and units of design.</p> <p>The surviving features and fabric of the building are not representative of one period, rather a culmination of historic work and changes over the past century. The Georgian origins of the building can be plainly seen however, the later internal alterations provide a multi-layered dimension to the building, introduced to facilitate the changing face of home ownership and technological advancements.</p>	<p>In good condition for the most part as a whole although the degradation and loss of some features has occurred in the past which is reflected mainly in the principle corner elevation where new brickwork has been introduced.</p> <p>Individual layout of the ground floor is subject to minor alteration. Features such as the existing timber staircase, timber floorboards, lath and plaster partitions and other surviving internal features will remain unchanged.</p>	<p>Evidential, Historical, Aesthetic and Communal value - Medium/High significance</p> <p>Adaptations to the dwelling after the Georgian period have been mostly restrained and sympathetic to the original construction. Exterior details and decorations have survived well and remain crucial to the heritage and character of the building block as a whole.</p>	<p>The collective survival of fabric and features of the building and later additions have been considered when designing the proposals. Where principle alterations are proposed, including the opening up of the top floor lift structure and repairs to the roof structure will not affect the collective character of the listed building.</p>	<p>Low Impact - The historic surviving floor plan, use and scale of the internal rooms are to be preserved. The proposed alterations to the utility room will have no visual impact on the character of the listed building nor the collective impression of individual historic features.</p>

6.2 Heritage Significance

Aspect of Significance/Description	Condition and Proposed Alteration	Significance and reason	Justification for Change	Impact Assessment
Windows:				
<p>Windows - Ground Floor</p> <p>Single glazed white painted softwood timber Georgian sash and Victorian casement window units with window bars. Windows were replaced during the late 19th Century refurbishment works and are not of original contemporaneous date to the mid-late 18th Century dwelling.</p>	<p>Ground floor windows are in fair condition. No change proposed to original timber frames. Frames to be preserved in situ and painted white where necessary.</p>	<p>Evidential, Historical, Aesthetic and Communal value - Low significance</p> <p>Indicative of hierarchy or internal room arrangement and of the fenestration to the dwelling. Individual and collective interest with other similar windows of style within the Moravian Settlement.</p>	<p>No changes proposed</p>	<p>No/Beneficial Impact - As a result of local repairs and maintenance of the existing window units. No adverse impact on the appearance of the existing windows.</p>
<p>Windows - First Floor</p> <p>Single glazed white painted softwood timber Victorian sash and Georgian casement window units with window bars. Original windows of contemporaneous date to the mid-late 18th Century dwelling.</p>	<p>Ground floor windows are in fair condition. No change proposed to original timber frames. Frames to be preserved in situ and painted white where necessary. Glass to panes to be replaced with slim-profile double glazed panes.</p>	<p>Evidential, Historical, Aesthetic and Communal value - High significance</p> <p>Indicative of hierarchy or internal room arrangement and of the fenestration to the dwelling. Individual and collective interest with other similar windows of style and age within the Moravian Settlement.</p>	<p>Replacement of non-original first floor window to room 1/4 as necessary is proposed to include the removal of the damaged timber sash window and installation of a like for like double glazed uPVC heritage sash window unit. The appearance of the window is to be replicated in its entirety ensuring that the collective architectural appearance of the property is preserved. The proposed installation of a double glazed unit is a reflection of the need and desire to improve the thermal performance of the dwelling without resulting in a majorly adverse impact on its historical appearance and character.</p>	<p>Low/Beneficial Impact - Low adverse impact on the appearance of the historic character of the dwelling as a result of the installation of a like for like double glazed heritage sash uPVC window unit.</p>
<p>Windows - Lintels</p> <p>Arched brick window heads/lintels to ground floor/first floor Victorian sash windows and ground floor Georgian casement window. Stone plinth window head/lintel to first floor Georgian sash windows and Victorian casement windows.</p>	<p>All window heads/lintels are in a good condition. General maintenance required and localised repair/repointing proposed in localised areas. No changes proposed.</p>	<p>Evidential, Historical, Aesthetic and Communal value - High significance</p>	<p>Repairs to brick head mortar joints with like for like materials using traditional techniques will reduce further deterioration of their condition.</p>	<p>No Adverse Impact</p>
<p>Windows - Ledges</p> <p>Stone plinth window ledges to ground/first floor Georgian sash windows and casement windows.</p>	<p>All window ledges are in a good condition. General maintenance required and localised repair/repointing proposed in localised areas. No changes proposed.</p>	<p>Evidential, Historical, Aesthetic and Communal value - High significance</p>	<p>Repairs to stone plinth ledges and mortar joints with like for like materials using traditional techniques will reduce further deterioration of their condition.</p>	<p>No Adverse Impact</p>

Moravian Settlement

Fairfield was the last of the Moravian settlements in England established in the 18th century, the original being Fulneck near Bradford in Yorkshire. The Moravians settled at Fairfield when the Church, Sisters' House and Brethren's' House were formally opened in 1783, the Settlement having been planned and built by members of the Moravian congregation who had been previously located in Dukinfield. The Settlement was self-contained and self-governed by its community, who based their aspirations upon a peaceful reform of the habits of the spirit.

The Fairfield Conservation Area lies just south of Manchester Road and Droylsden town centre and is surrounded by housing. Nevertheless, it is rather hidden from those passing by and remains an enclave with an air of seclusion and calm and is distinct in character from its surroundings. The Ashton Canal passes through the northern part of the area.

The area comprises several sub-areas of differing character. There is the historic late 18th century Moravian Settlement at its heart; the more recent early 20th century Garden Village extension of this to the south, and an area of distinct character associated with the Canal. There is also an area of late 1970s social housing which lies between the Moravian Settlement and the Canal to the north.

The form of the original Moravian Settlement is exemplified by a simple grid street pattern. This was derived from the historic tradition of male/female segregation and is evidenced by the naming of 'Brethren's Street' and 'Sisters' Street', merging from the central thoroughfare 'Fairfield Square'. The streets are well proportioned and enclosed by a back- of-pavement building line. The width of the streets is made more human in scale by provision of mature trees in the middle. Cobbled street surfaces survive.



Moravian College,
14 Fairfield Square,
Manchester, M43 6AD.
+44 [0]161 370 6166
mail@architecture.co.uk
www.architecture.co.uk

Revision Notes

Project Title

18 Fairfield Square

Date

12.12.23

Drawn By

MDW

Scale @ A3

1:1250

Drawing Title

Location Plan

Job Number

550

Status

S

Drawing Number

001

Revision

-

Design and drawings are copyright of Architecture:m. Written permission must be sought before duplication. Any discrepancy found between information given on this drawing and that given elsewhere recorded on site shall be notified immediately to the architect in writing. Do not scale from this drawing or derive dimensions from digital media. All dimensions are to be checked prior to works commencing on site. Design and drawings are copyright of Architecture:m. Written permission must be sought before duplication. Any discrepancy found between information given on this drawing and that given elsewhere recorded on site shall be notified immediately to the architect in writing. Do not scale from this drawing or derive dimensions from digital media. All dimensions are to be checked prior to works commencing on site.

- 550.25-100-Existing Site Plan
- 550.25-101-Ground Floor Existing
- 550.25-102-First Floor Existing
- 550.25-110-Front Elevation Existing
- 550.25-111-Side Elevation Existing
- 550.25-400-Window Schedule

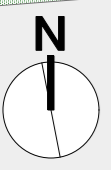
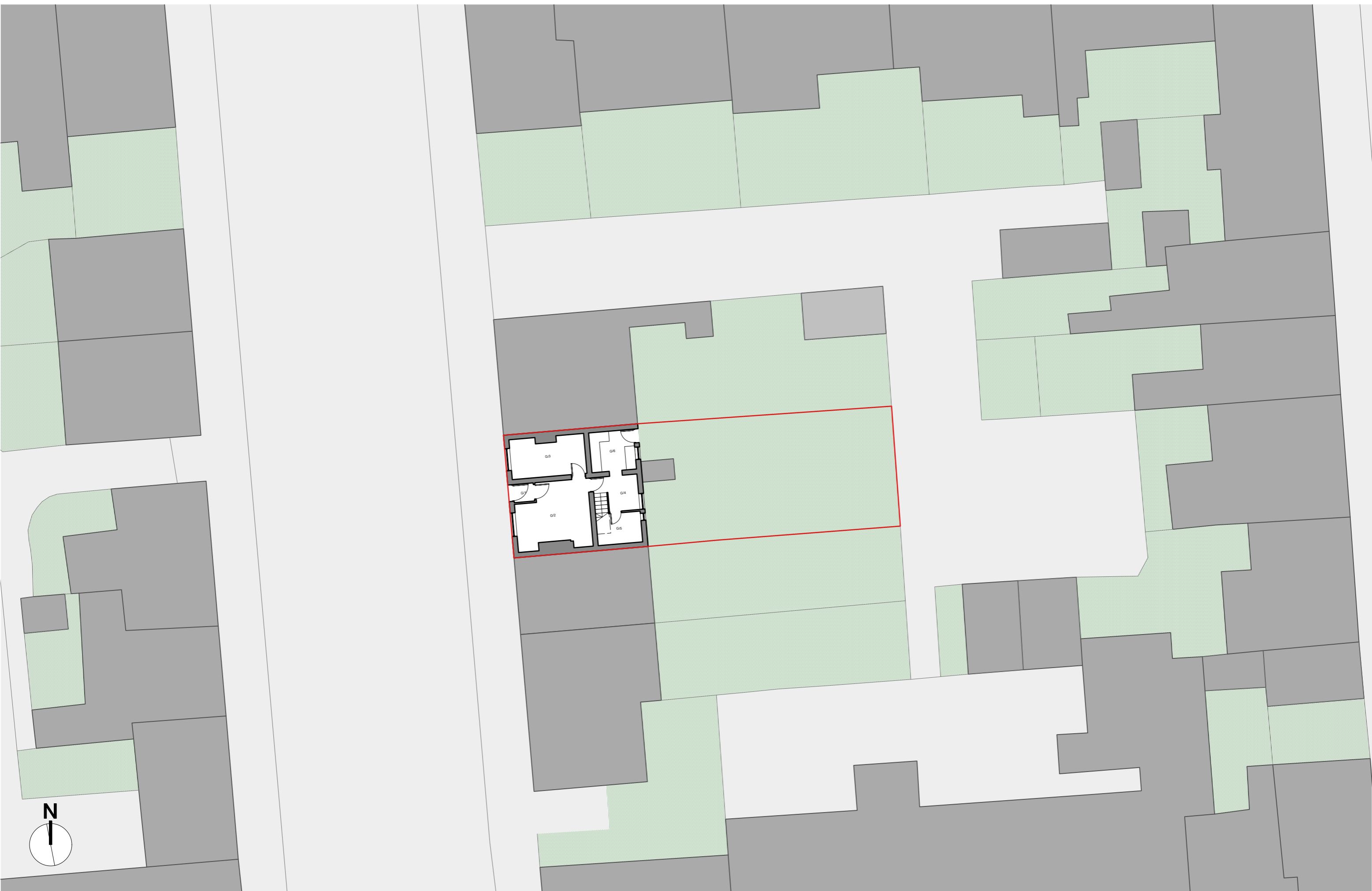

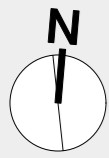
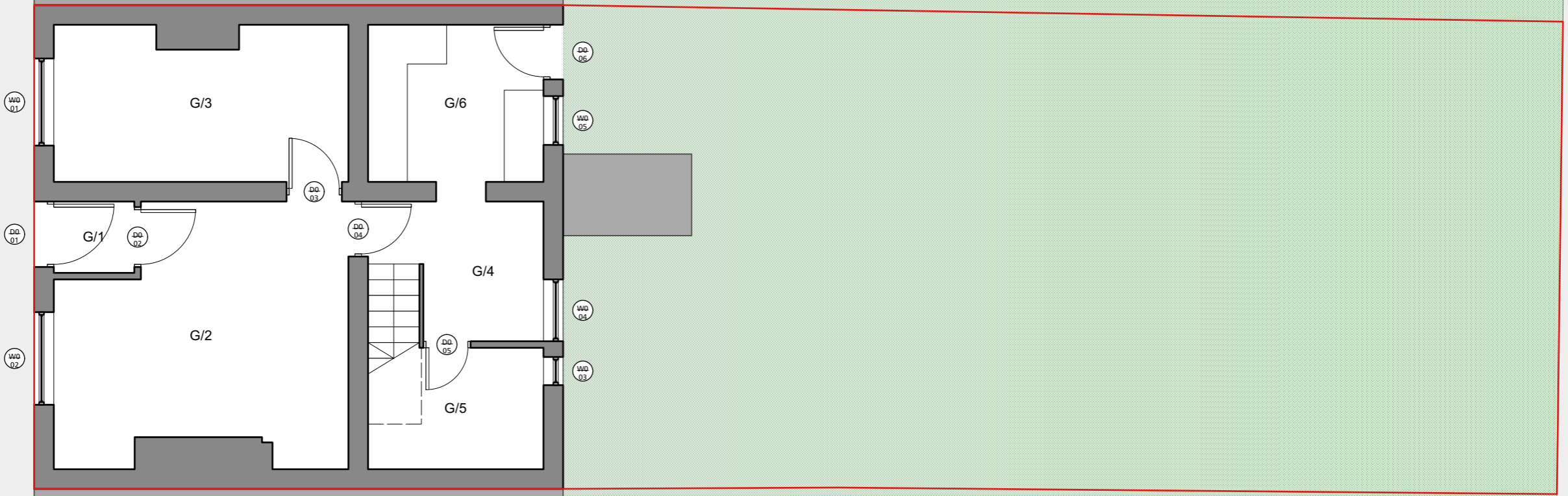

Sash window to be replaced.
See window schedule and technical information for dimensions and specification.

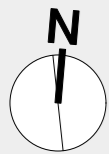
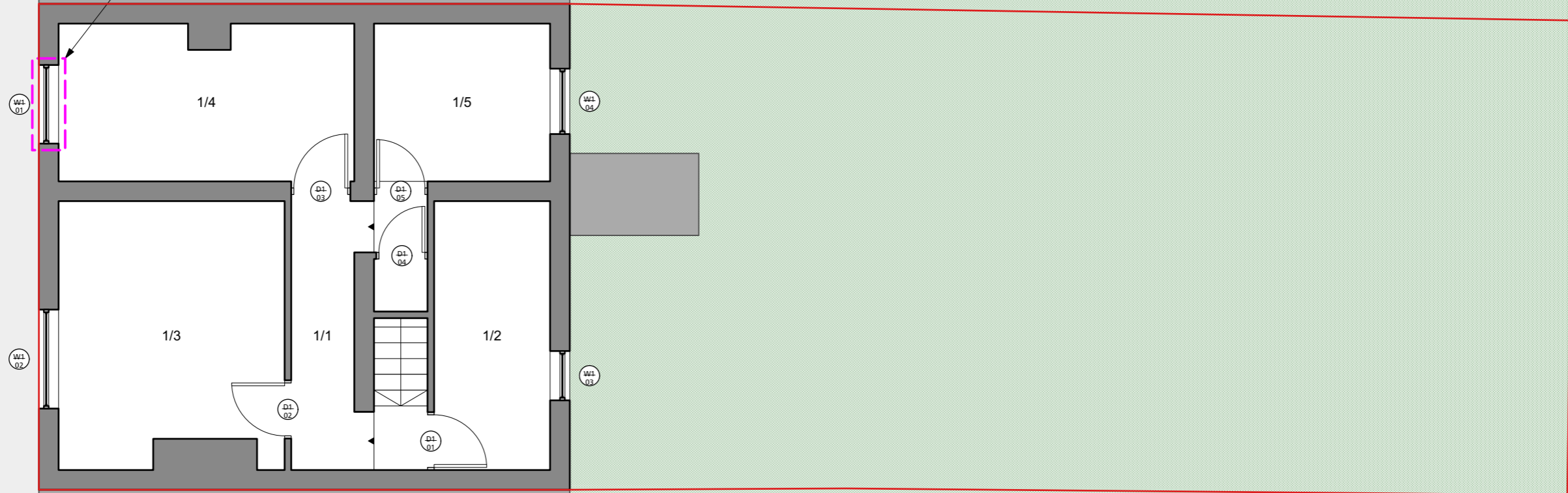



Sash window to be replaced.
See window schedule and technical information for dimensions and specification.

*N.B See annotations for frontal elevation proposal remarks**



*N.B No proposals to the rear elevation**

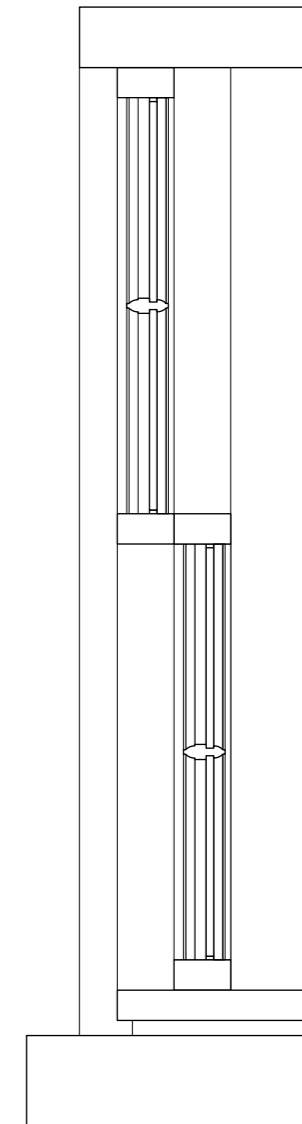
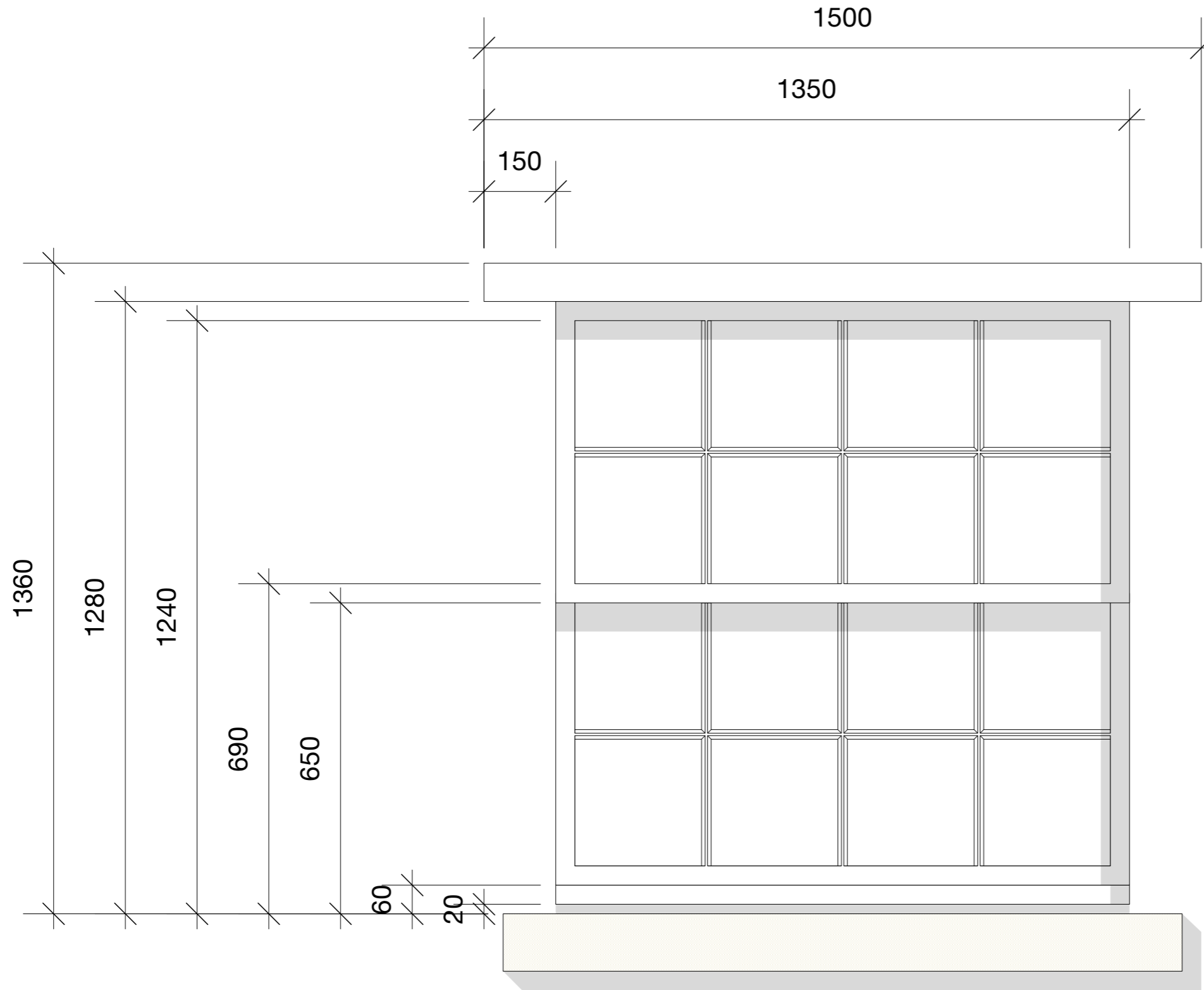

W1
01



Seamless run-through horns



Seamless no horn option



Seamless 35mm meeting rail



Traditional globe furniture



True mechanical joints



Authentic astragal bars



Optional deep cill



Optional staff bead



The Ultimate Rose

- Closed-end true mechanical joints
- Ultra-slim 35mm seamless midrail
- Seamless run-through sash horns
- Slim putty-line external profiles
- Deep bottom rail
- Optional removable staff bead
- Optional external chamber covers (coming soon)
- Aluminium-mounted authentic astragal bars
- Optional period deep cill
- Range of finishes and woodgrains
- Traditional globe furniture
(note: acorn furniture required for Part Q/PAS 24)
- Tilting sashes for simple cleaning
- Maintenance-free - no more painting
- Widely specified in conservation areas

Ultimate
Rose

Technical Details

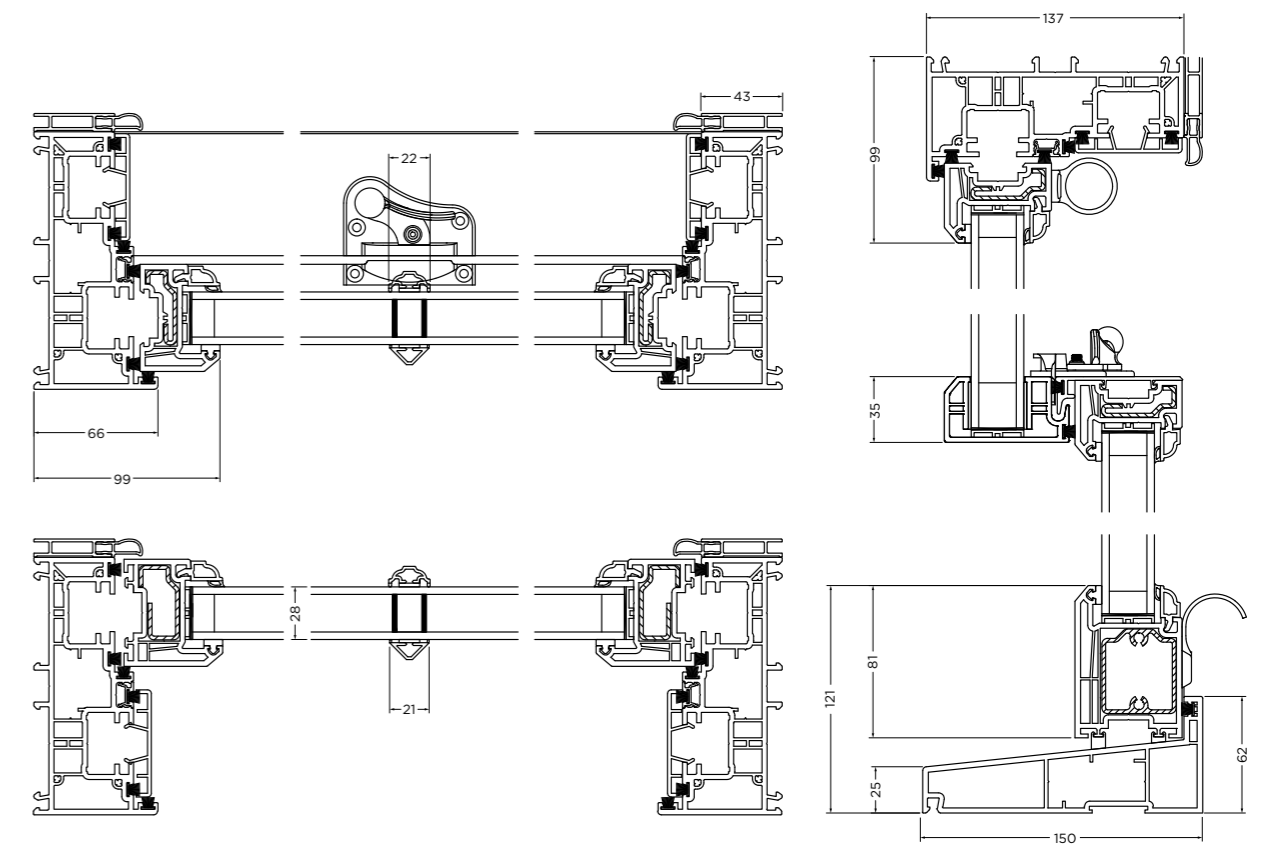

- A Rated
- Acoustics
- PartQ/PAS24/SBD
- Mechanical Joints
- Seamless Horns
- No Horn
- Deep Cill
- Slim Mullion

Icons with borders are standard features. Ones without borders are options.

