

MAXI UNIPLEX CEILING SYSTEM 1/2 HOUR FIRE RATED	
MAXI DROPPED CEILING	
AIRBORNE	IMPACT
DfT = 150 dB	DfT = 120 - 140 dB
DfT = 150 dB	DfT = 120 - 140 dB

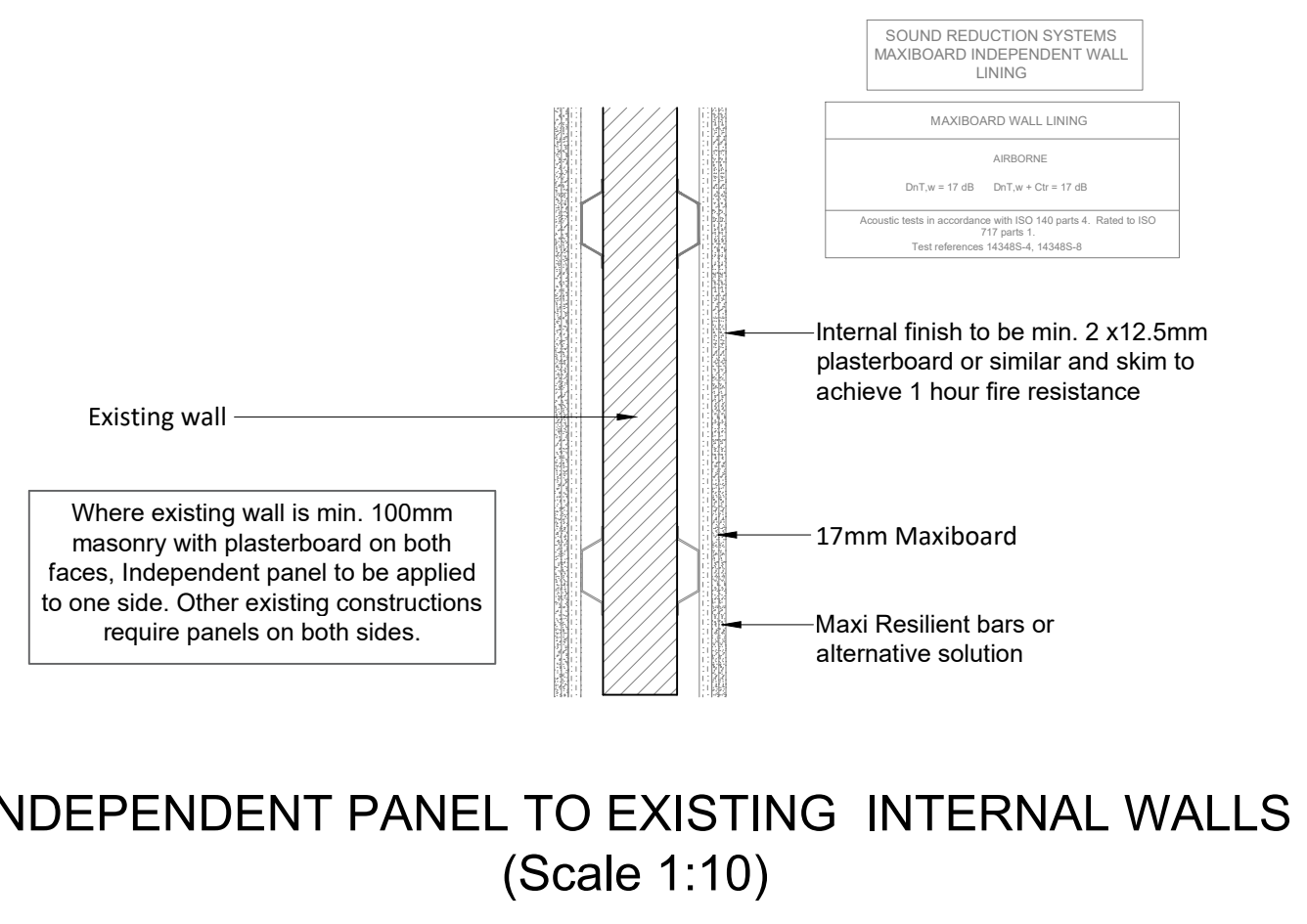

DETAIL 1

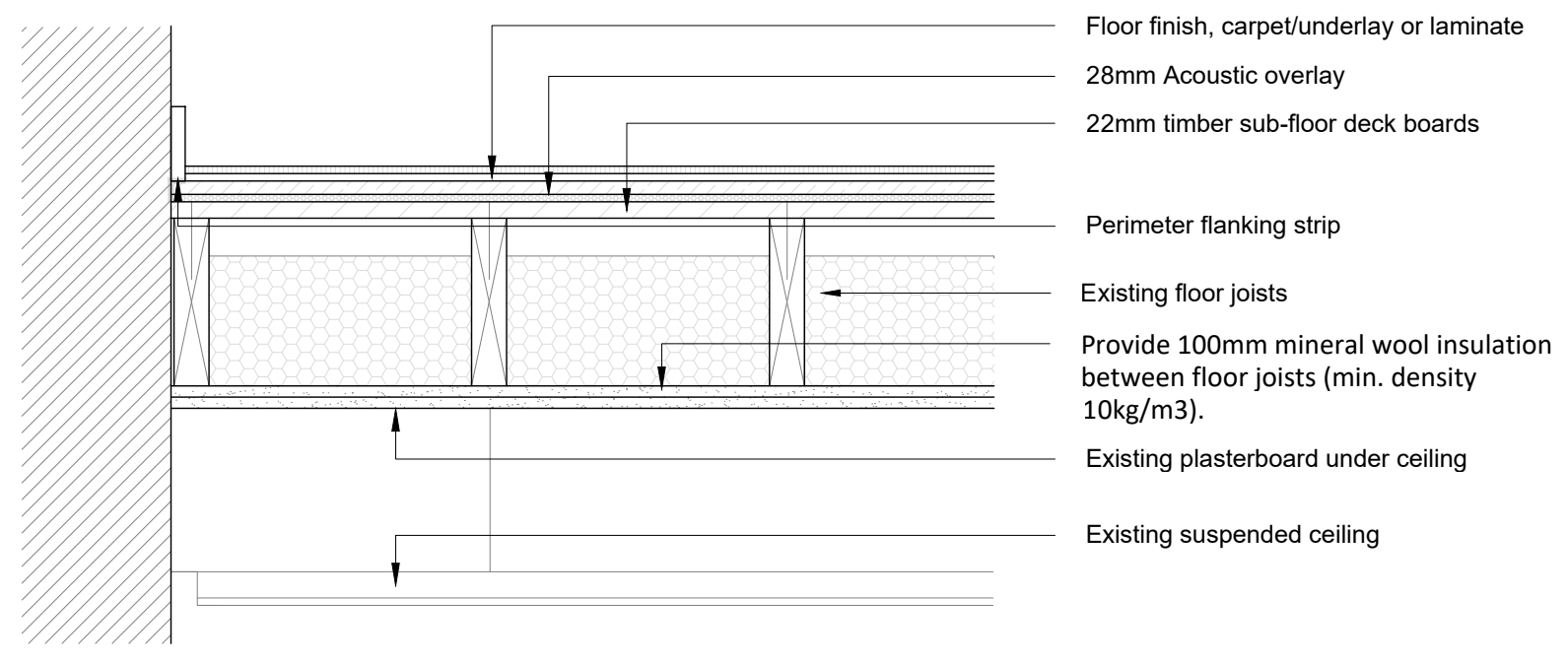

ACOUSTIC SEPARATING FLOORS
(BETWEEN RETAIL AND RESIDENTIAL)
(Scale 1:10)

DETAIL 5

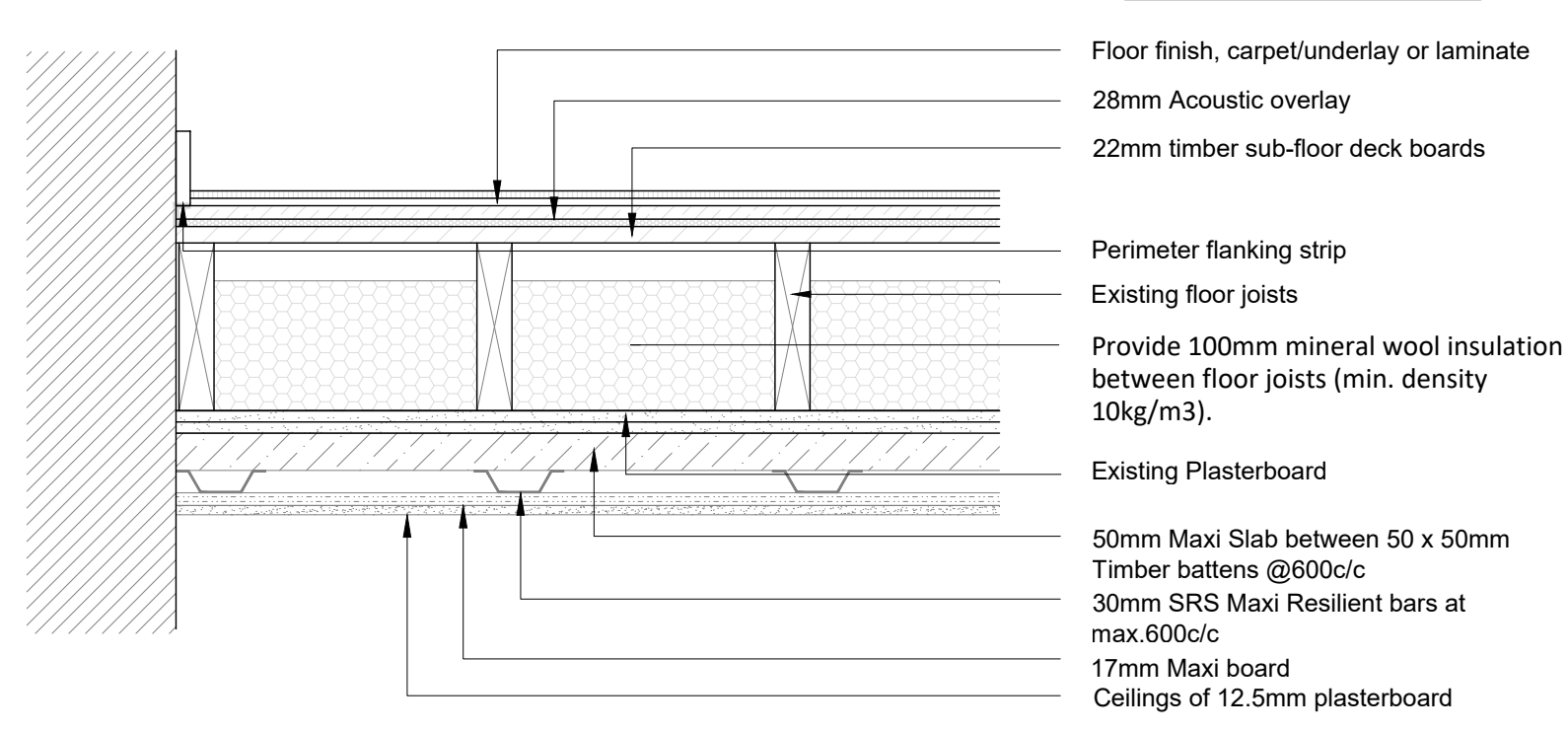

ACOUSTIC SEPARATING FLOORS (BETWEEN FLATS)
(Scale 1:10)

DETAIL 8

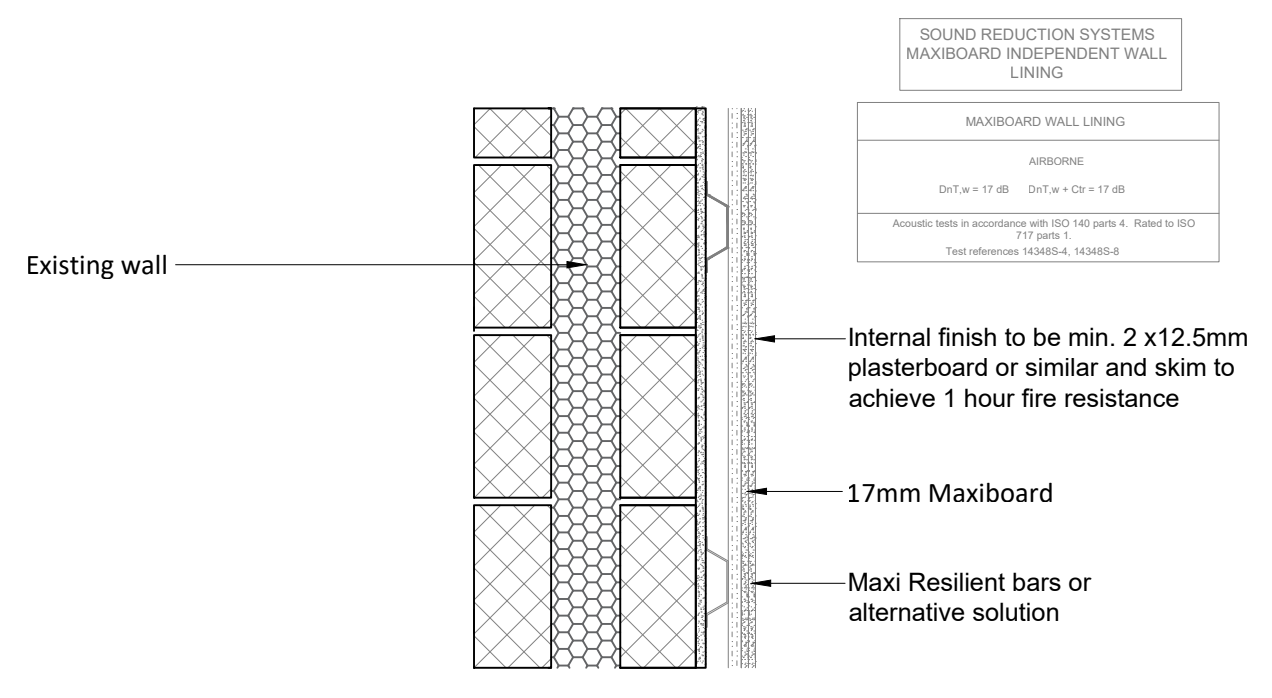

GARAGE WALL UPGRADE (Scale 1:10)

DETAIL 2

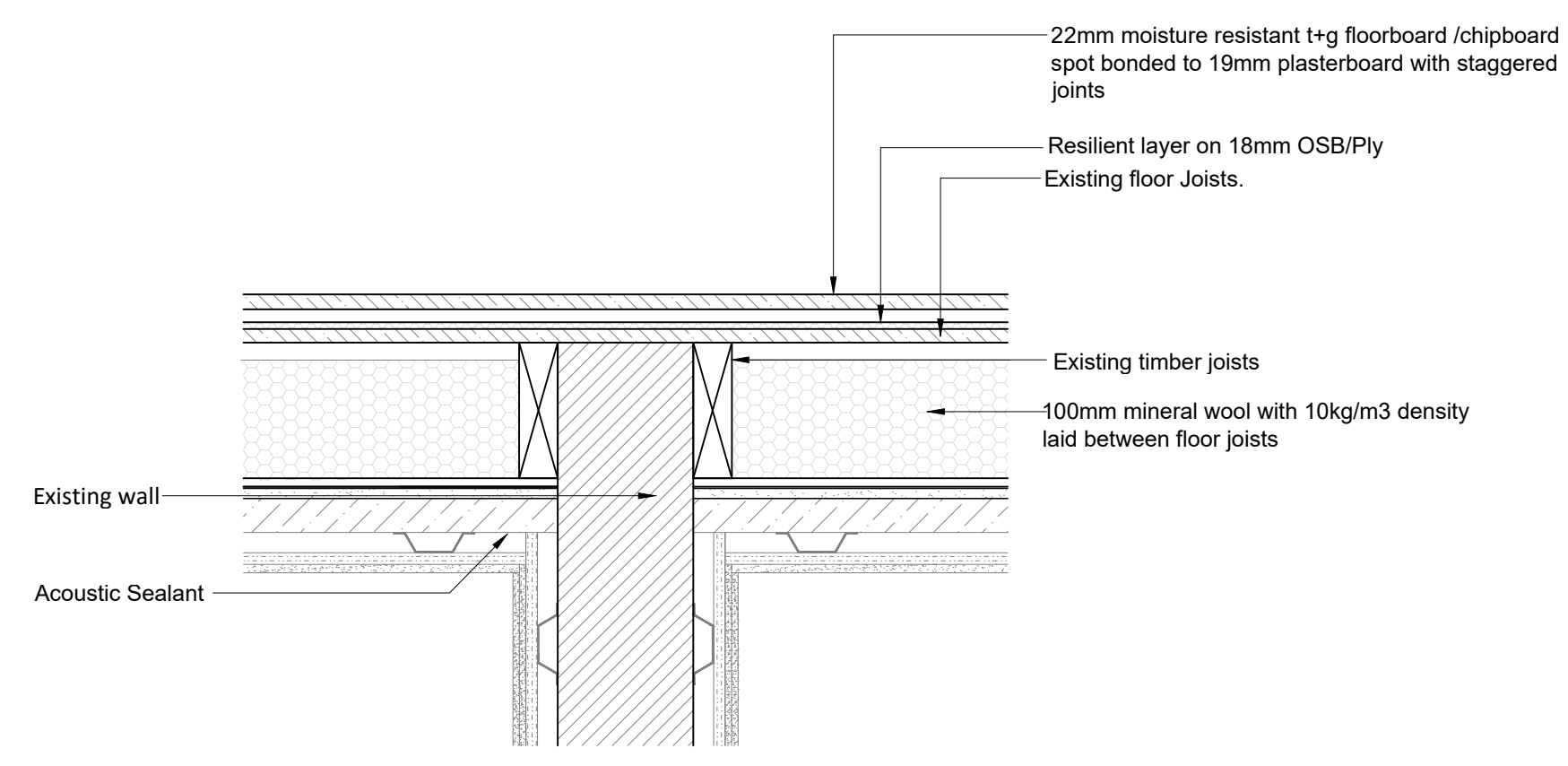

PARTY WALL TO PARTY FLOOR JUNCTION
(Scale 1:10)

DETAIL 6

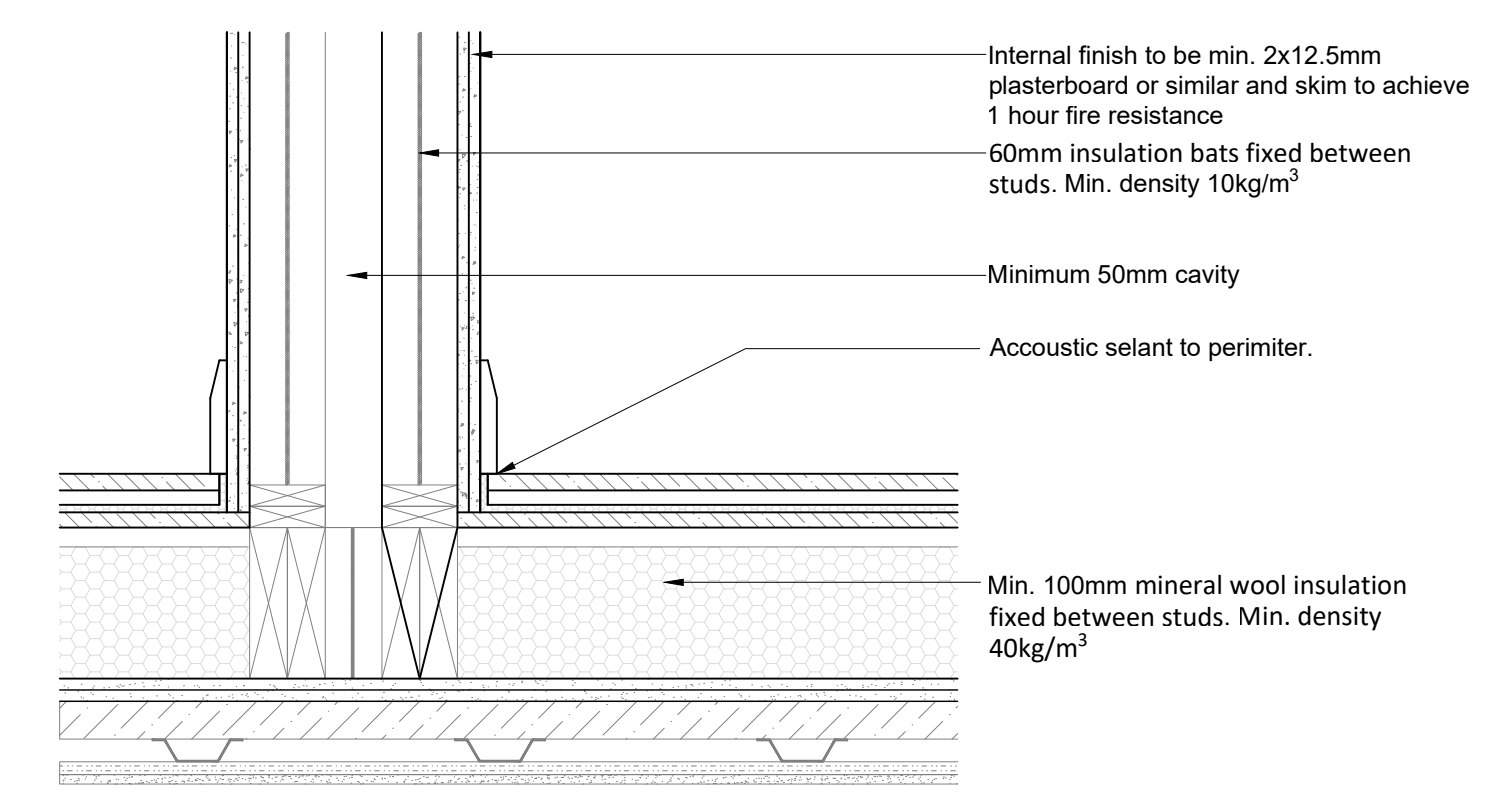

PARTY WALL TO PARTY FLOOR JUNCTION
(Scale 1:10)

DETAIL 9

INDEPENDENT PANEL TO EXISTING EXTERNAL WALLS
(Scale 1:10)

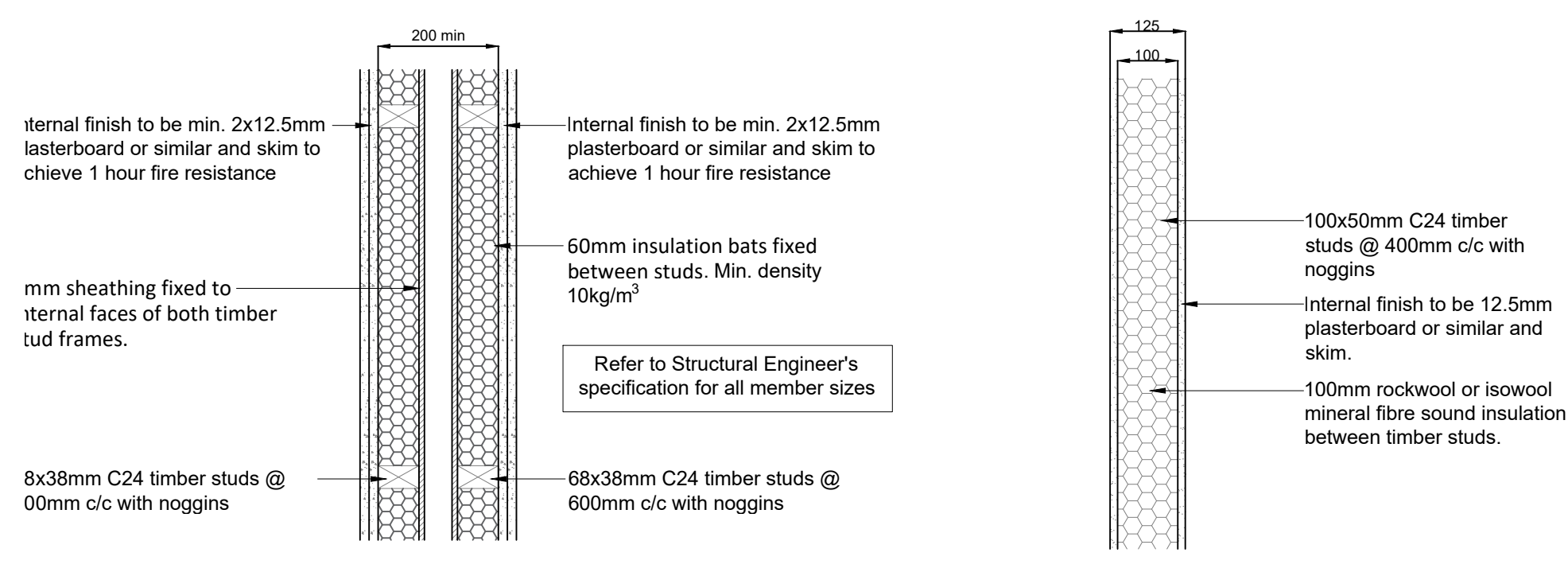

TIMBER FRAMED SEPARATING WALL
(Scale 1:10)

DETAIL 3

INTERNAL STUD PARTIION
(Scale 1:10)

DETAIL 4

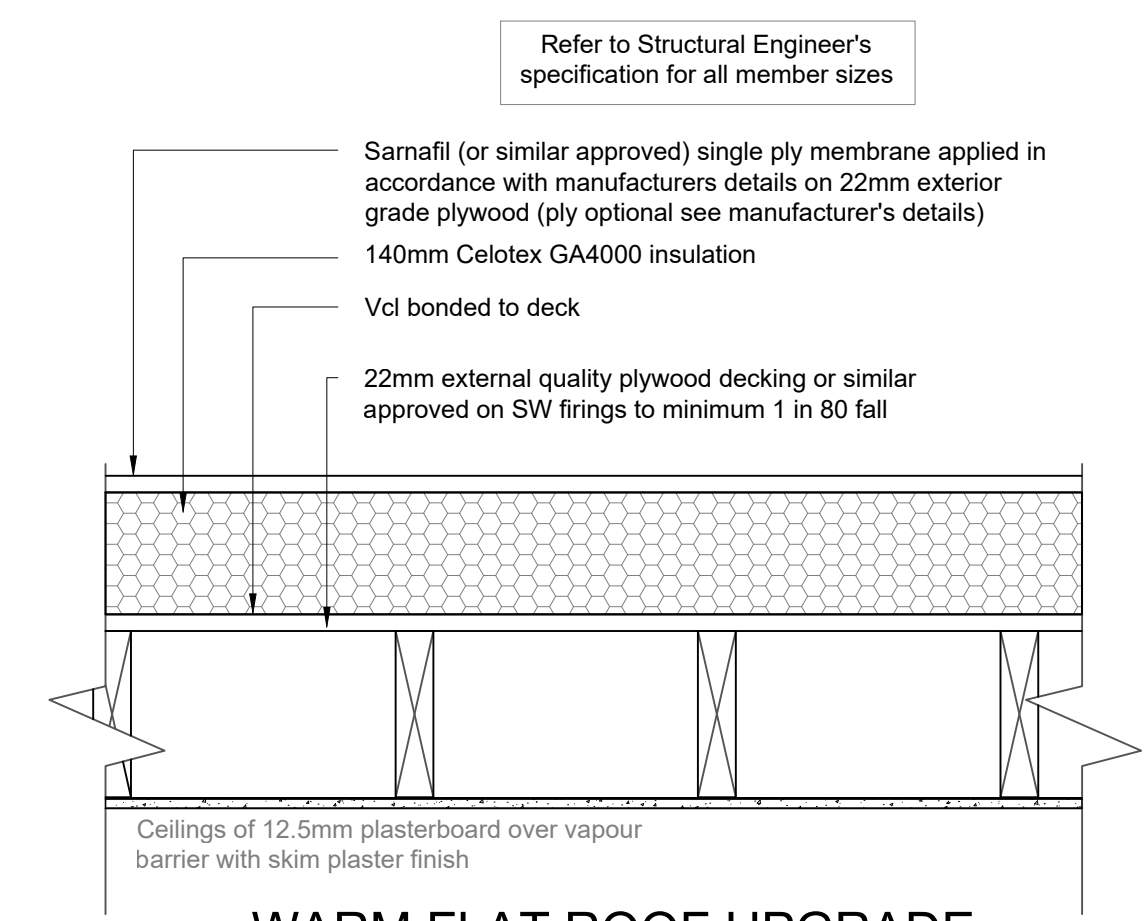

WARM FLAT ROOF UPGRADE
(Scale 1:10)

DETAIL 7

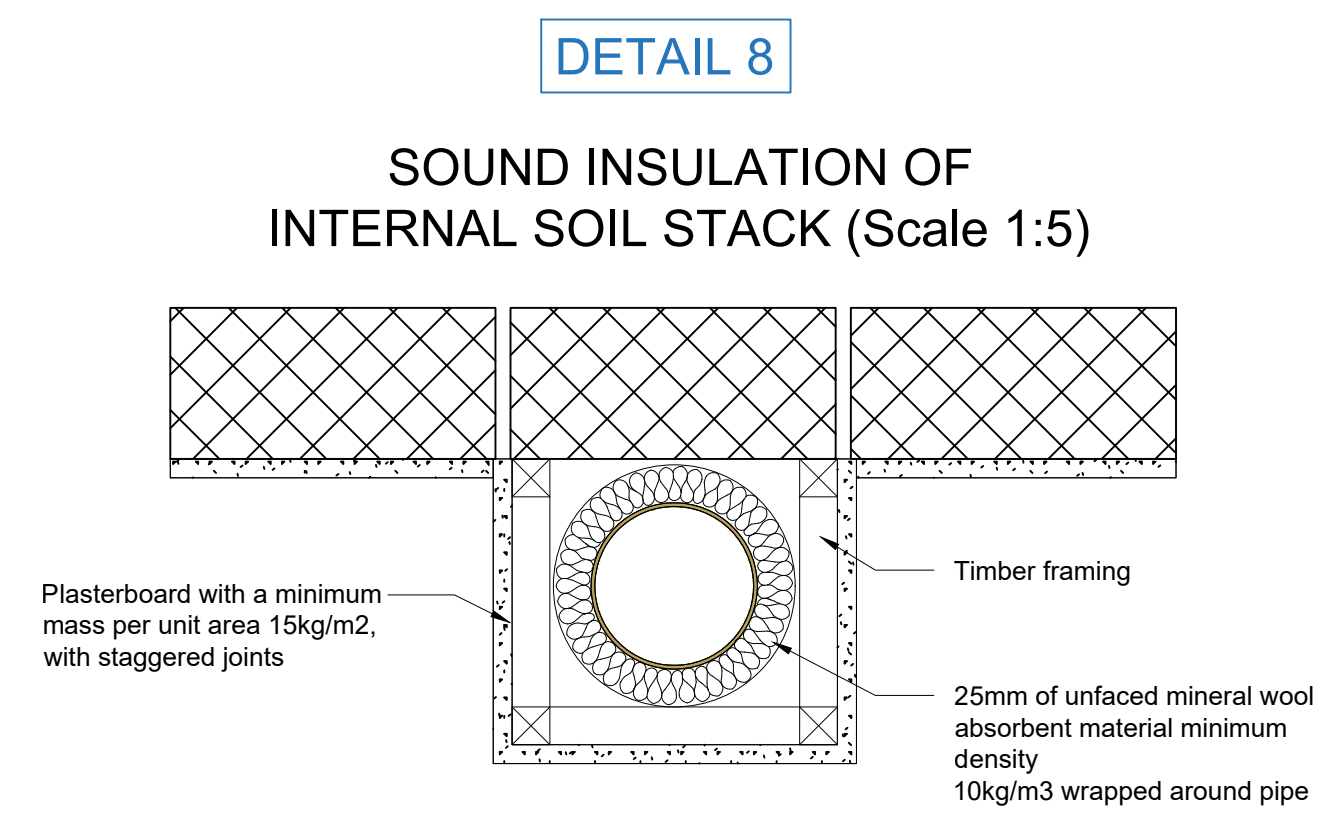

SOUND INSULATION OF
INTERNAL SOIL STACK (Scale 1:5)

DETAIL 8

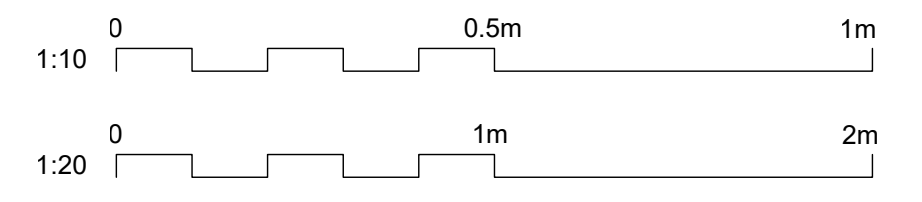

- NOTES:
- All dimensions to be checked on site.
 - Any discrepancies to be reported back to CR Design Services.
 - This drawing is part of a Building Control package, and should only be used for Building Control purposes.
 - Refer to Structural Engineer's drawings and specification for all structural elements.

Rev.	Date	Description

DRAWING NO	DATE	DRAWING	PROJECT
3006-T1	16.08.23	ACOUSTIC MITIGATION DETAILS	NORWOOD HOUSE, 9 DYKE ROAD, BN1 3FE
DRAWN	SCALE		
JJ	AS SEEN @ A1		

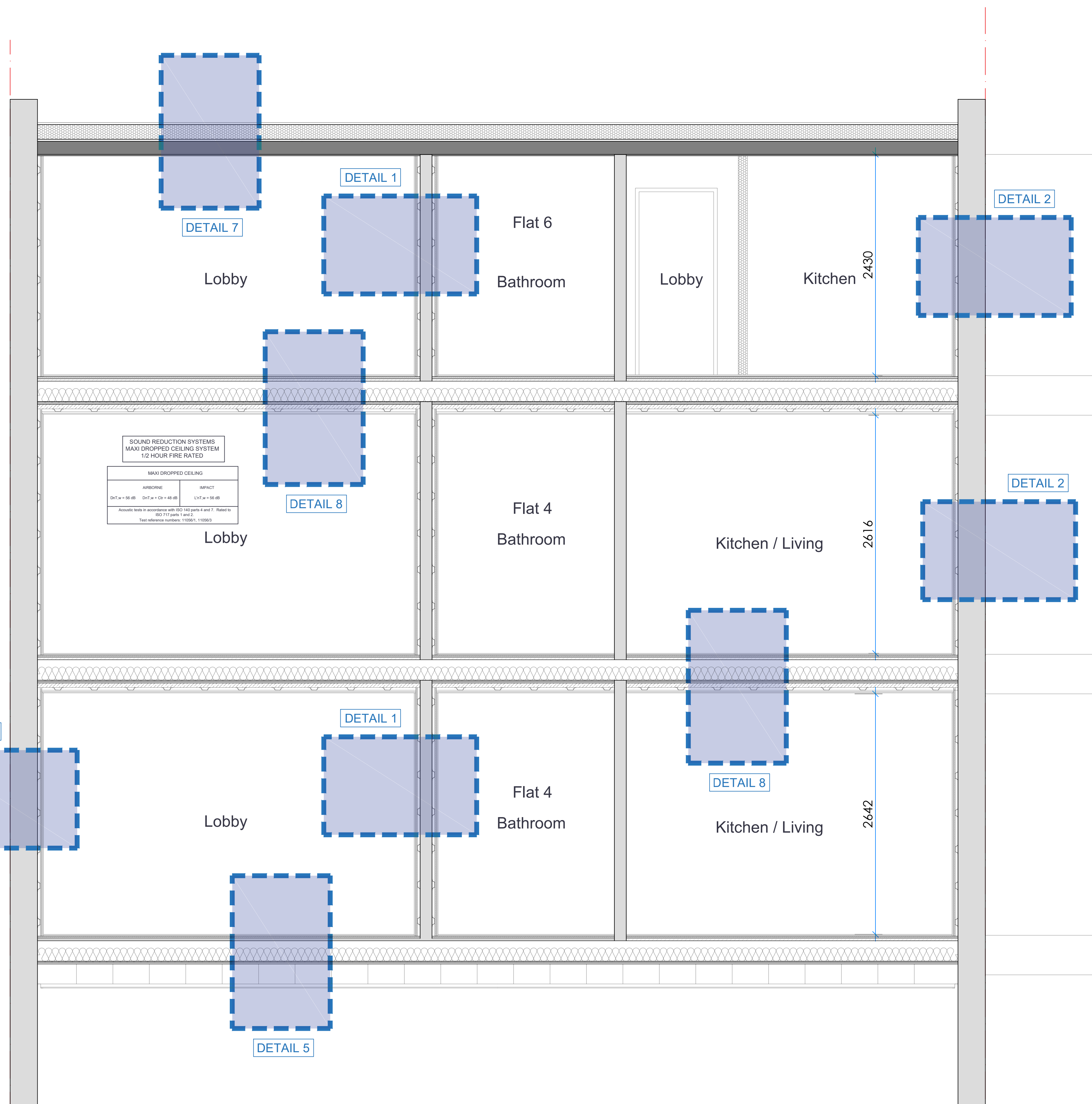

T2 ACOUSTIC MITIGATION DETAILS
SCALE 1:20 @ A1

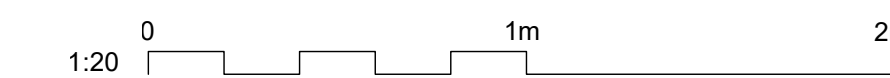

CRDesignServices

Salvus House, Aykley Heads,
Durham, DH1 5TS
sales@crdesignservices.co.uk
www.crdesignservices.co.uk
Tel: 0191 645 6000

NOTES:

1. All dimensions to be checked on site.
2. Any discrepancies to be reported back to CR Design Services.
3. This drawing is part of a Building Control package, and should only be used for Building Control purposes.
4. Refer to Structural Engineer's drawings and specification for all structural elements.

Rev. Date Description

DRAWING NO	DATE	DRAWING	PROJECT
3006-T2	16.08.23	ACOUSTIC MITIGATION DETAILS	NORWOOD HOUSE, 9 DYKE ROAD, BN1 3FE
DRAWN	SCALE		
JJ	1:20 @ A1		