

Specialist Building Products Ltd t/a KestrelBce

Billet Lane
Normanby Enterprise Park
Normanby Road
Scunthorpe
North Lincolnshire DN15 9YH
Tel: 01724 400440 Fax: 01724 280241
e-mail: info@kestrelbce.co.uk
website: www.kestrelbce.co.uk



Agrément Certificate
11/4835
Product Sheet 1

SPECIALIST BUILDING PRODUCTS ROOFLINE SYSTEMS

KESTREL PVC-UE ROOFLINE SYSTEM

This Agrément Certificate Product Sheet⁽¹⁾ relates to Kestrel PVC-UE Roofline System, comprising white fascia, soffit and barge boards, soffit ventilators and accessories, for external use at the roofline as a substitute for timber or other conventional materials.

(1) Hereinafter referred to as 'Certificate'.

CERTIFICATION INCLUDES:

- factors relating to compliance with Building Regulations where applicable
- factors relating to additional non-regulatory information where applicable
- independently verified technical specification
- assessment criteria and technical investigations
- design considerations
- installation guidance
- regular surveillance of production
- formal three-yearly review.



KEY FACTORS ASSESSED

Ventilation — the soffit ventilators can contribute towards providing the necessary roof space ventilation (see section 6).

Strength and stability — in terms of wind loading resistance, the system can be used in all areas of the UK (see section 7).

Performance in relation to fire — when tested in accordance with BS 476-7 : 1987 the 22 mm cellular board achieved a Class 1 surface spread of flame rating and the 9 mm board achieved a Class 1Y rating. When tested in accordance with BS 476-7 : 1997 the 16 mm and 18 mm boards achieved a Class 1 rating (see section 8).

Durability — the system will retain adequate impact resistance and its decorative function for a period in excess of 35 years with only minor changes in surface appearance (see section 10).

The BBA has awarded this Certificate to the company named above for the system described herein. This system has been assessed by the BBA as being fit for its intended use provided it is installed, used and maintained as set out in this Certificate.

On behalf of the British Board of Agrément

Date of Third issue: 6 November 2015

Originally certificated on 19 July 2011

John Albon — Head of Approvals

Construction Products

Claire Curtis-Thomas

Chief Executive

The BBA is a UKAS accredited certification body — Number 113. The schedule of the current scope of accreditation for product certification is available in pdf format via the UKAS link on the BBA website at www.bbacerts.co.uk

Readers are advised to check the validity and latest issue number of this Agrément Certificate by either referring to the BBA website or contacting the BBA direct.

British Board of Agrément
Bucknalls Lane
Watford
Herts WD25 9BA

©2015

tel: 01923 665300
fax: 01923 665301
clientservices@bba.star.co.uk
www.bbacerts.co.uk

Regulations

In the opinion of the BBA, Kestrel PVC-UE Roofline System, if installed, used and maintained in accordance with this Certificate, can satisfy or contribute to satisfying the relevant requirements of the following Building Regulations (the presence of a UK map indicates that the subject is related to the Building Regulations in the region or regions of the UK depicted):



The Building Regulations 2010 (England and Wales) (as amended)

Requirement:	C2(b)	Resistance to moisture
Comment:		The system will contribute to providing protection against the ingress of moisture. See section 4.1 of this Certificate.
Requirement:	C2(c)	Resistance to moisture
Comment:		The soffit ventilators can contribute to enabling a roof to satisfy this Requirement. See section 6 of this Certificate.
Regulation:	7	Materials and workmanship
Comment:		The components of the system are acceptable. See section 10.1 and the <i>Installation</i> part of this Certificate.



The Building (Scotland) Regulations 2004 (as amended)

Regulation:	8(1)(2)	Durability of workmanship and fitness of materials
Comment:		The system is acceptable. See sections 9.1, 9.2 and 10.1 and the <i>Installation</i> part of this Certificate.
Regulation:	9	Building standards applicable to construction
Standard:	3.10	Precipitation
Comment:		The system will contribute to satisfying this Standard, by providing protection against the ingress of moisture, with reference to clause 3.10.1 ⁽¹⁾⁽²⁾ . See section 4.1 of this Certificate.
Standard:	3.15	Condensation
Comment:		The soffit ventilators can contribute to enabling a roof to satisfy this Standard, with reference to clauses 3.15.1 ⁽¹⁾⁽²⁾ , 3.15.3 ⁽¹⁾⁽²⁾ , 3.15.5 ⁽¹⁾⁽²⁾ and 3.15.7 ⁽¹⁾⁽²⁾ . See section 6 of this Certificate.
Regulation:	12	Building standards applicable to conversions
Comment:		All comments given for these systems under Regulation 9, Standards 1 to 6, also apply to this Regulation, with reference to clause 0.12.1 ⁽¹⁾⁽²⁾ and Schedule 6 ⁽¹⁾⁽²⁾ . (1) Technical Handbook (Domestic). (2) Technical Handbook (Non-Domestic).



The Building Regulations (Northern Ireland) 2012 (as amended)

Regulation:	23	Fitness of materials and workmanship
Comment:		The system is acceptable. See section 10.1 and the <i>Installation</i> part of this Certificate.
Regulation:	28(b)	Resistance to moisture and weather
Comment:		The system will contribute to providing protection against the ingress of moisture. See section 4.1 of this Certificate.
Regulation:	29	Condensation
Comment:		The soffit ventilators can contribute towards enabling a roof to satisfy the requirements of this Regulation. See section 6 of this Certificate.

Construction (Design and Management) Regulations 2015

Construction (Design and Management) Regulations (Northern Ireland) 2007

Information in this Certificate may assist the client, Principal Designer/CDM co-ordinator, designer and contractors to address their obligations under these Regulations.

See section: 12 *General* (12.3 and 12.7) of this Certificate.

Additional Information

NHBC Standards 2014

NHBC accepts the use of Kestrel PVC-UE Roofline System, provided it is installed, used and maintained in accordance with this Certificate, in relation to *NHBC Standards*, Chapter 7.2 *Pitched roofs*.

1 Description

1.1 The Kestrel PVC-UE Roofline System comprises a range of white PVC-UE soffit, fascia and barge boards, soffit ventilators and ancillary components including extruded trims and injection moulded joints (see Figures 1, 2 and 3 and Table 1). The components of the system are available in three shades of white: standard white, dove and brilliant white.

1.2 The PVC-UE boards are composed of a closed cell cellular PVC-U core beneath an impact modified, outer weathering PVC-U skin. The trims consist of extrusions in impact modified PVC-U or injection mouldings in PVC-U.

1.3 The soffit ventilation products, which include the vented cellular boards, ventilator trims and over-facia ventilator, provide a means of ventilating the roof void.

1.4 The boards are extruded in standard 5 m lengths with a nominal density of $420 \text{ kg}\cdot\text{m}^{-3}$ and a skin thickness of 0.5 mm and are available in a range of thicknesses and widths (see Figure 1 and Table 1).

Table 1 Fascia/barge and soffit boards

	Product code	Overall thickness (mm)	Width (mm)
Fascia/barge boards	605	9	150 –600
	008	9	150 –405
	505	9	150 –405
	K16	16	150 –405
	KF16	16	150 –405
	KB16	16	150 –405
	018	18	150 –405
	K22	22	150 –405
Soffit boards	603	9	100 –600
	671/ 100	6	100
	871/ 100	6	100
	803	9	100 –150
	670/ 150	6	150
	903	9	150 –450

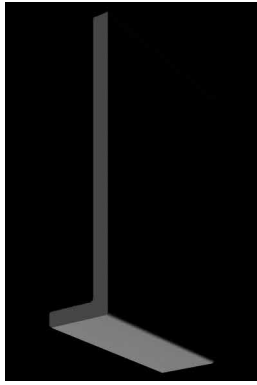

605

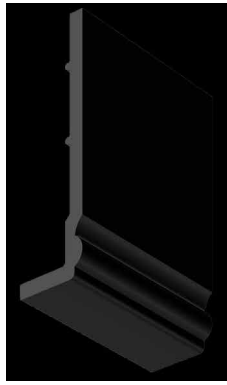

008

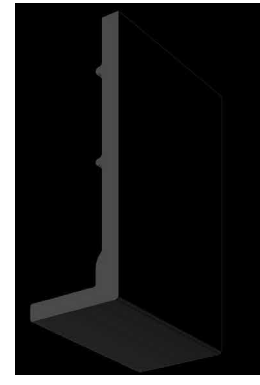

505

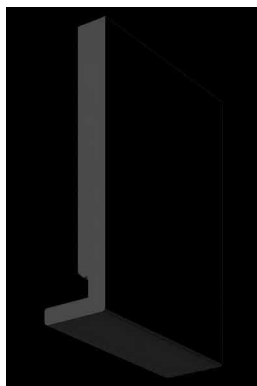

K16

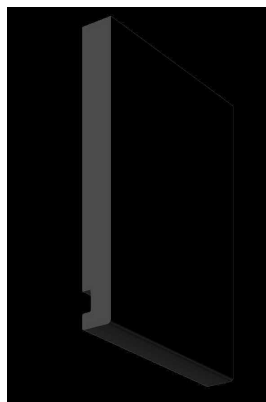

KF16

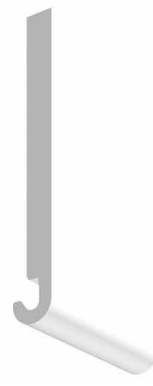

KB16

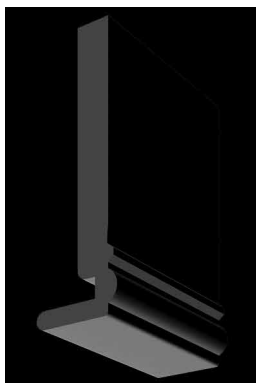

018

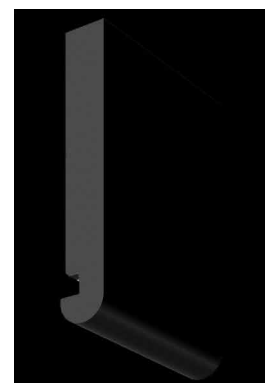

K22

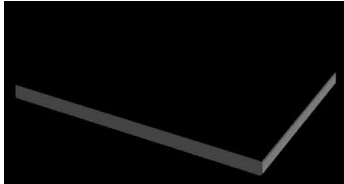

603

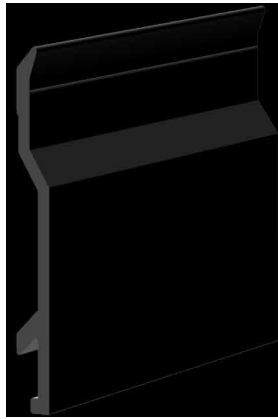

671/100

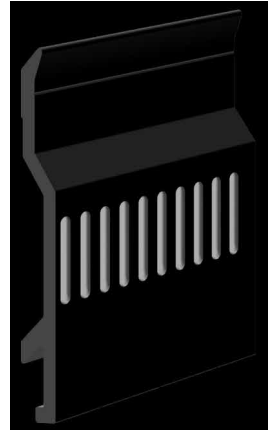

871/100

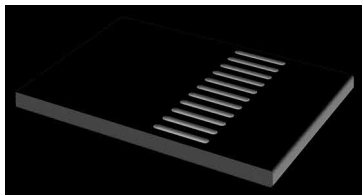

803



670/150

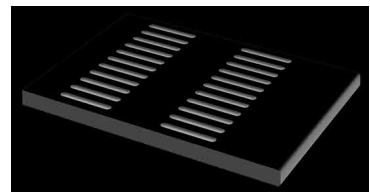

903

Figure 3 Selection of typical components and trims

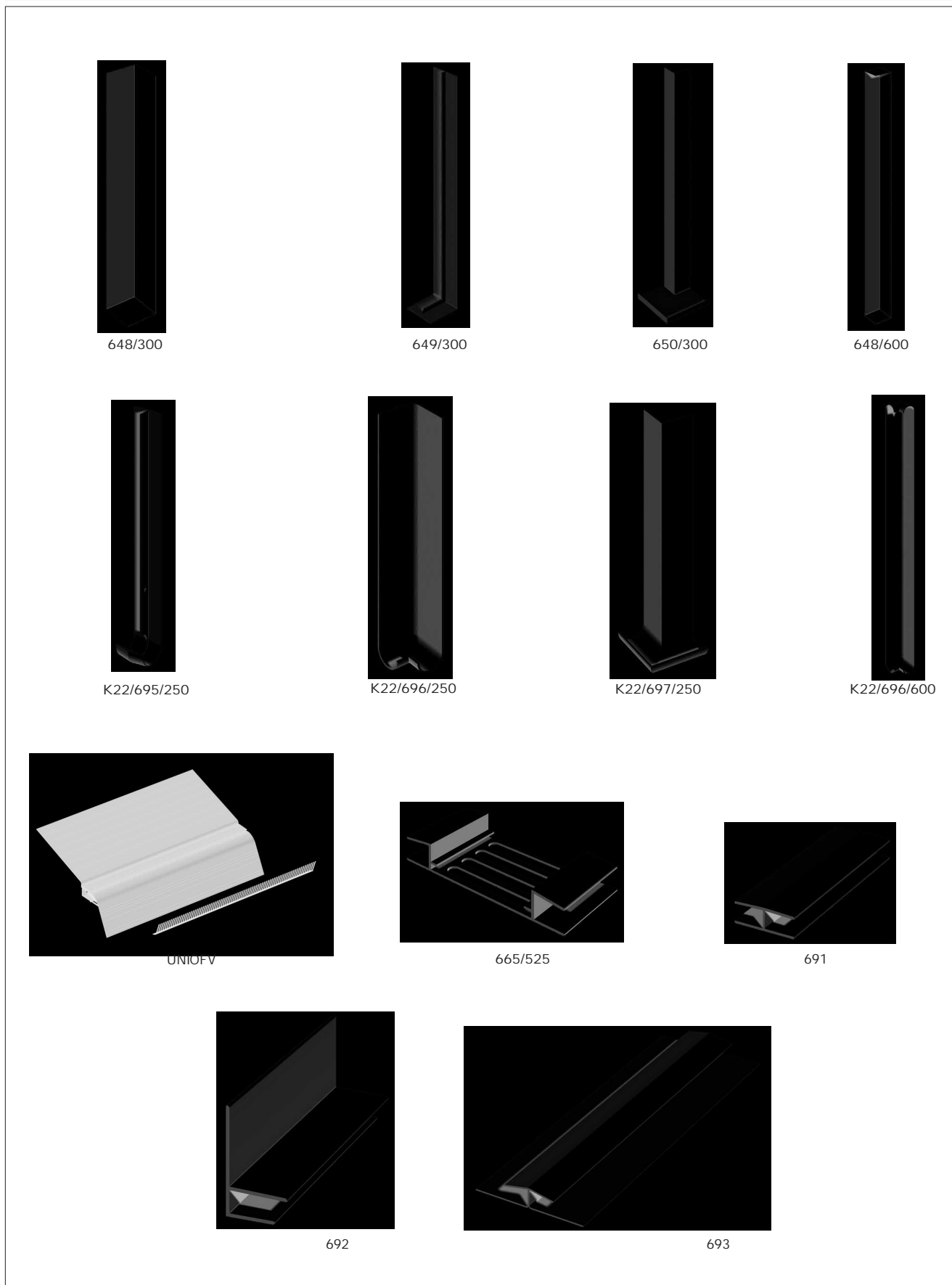

1.5 Ancillary items specified by the Certificate holder for use with the system, but outside the scope of this Certificate, include:

- stainless steel screws —a range of stainless steel screws with white plastic heads or annular ring shank nails for fixing the boards and gutter brackets to sound roof timbers (see Table 2)
- silicone sealant —low modulus for fixing joints.

Table 2 System components and their recommended fixings

Component thickness	Type of fixing
9 mm fascia/barge board	Plastic headed 40 mm x 4 mm austenitic stainless steel screws ⁽¹⁾ or 50 mm x 3 mm austenitic annular ring shank, stainless steel nails
16 mm, 18 mm and 22 mm fascia/barge boards	Plastic headed 50 mm x 4 mm austenitic stainless steel screws ⁽¹⁾ or 65 mm x 3 mm austenitic annular ring shank, stainless steel nails
Soffit boards	Plastic headed 40 mm x 2.1 mm austenitic annular ring shank, stainless steel pins
Cladding soffits	30 mm x 2.1 mm austenitic annular ring shank, stainless steel pins ⁽¹⁾
Over fascia ventilator	30 mm x 2.1 mm austenitic annular ring shank, stainless steel pins ⁽¹⁾
Gutter brackets ⁽²⁾	25 mm x 4.8 mm parallel thread austenitic stainless steel screws

(1) A4 to BS EN 3506-1 : 2009.

(2) For fixing to 16 mm, 18 mm and 22 mm fascia board.

2 Manufacture

2.1 The PVC-UE boards are manufactured by co-extruding a high-impact calcium/zinc PVC-U compound onto a foamed calcium/zinc PVC-UE compound, cooling and forming to section. Cellular PVC-U is formed during the process by the evolution of gas from blowing agents present in the PVC-U compound. A transparent polythene film is applied to the outer face of the extrusion before the board is cut to length.

2.2 The trims are manufactured using conventional extrusion and injection moulding techniques.

2.3 As part of the assessment and ongoing surveillance of product quality, the BBA has:

- agreed with the manufacturer the quality control procedures and product testing to be undertaken
- assessed and agreed the quality control operated over batches of incoming materials
- monitored the production process and verified that it is in accordance with the documented process
- evaluated the process for management of nonconformities
- checked that equipment has been properly tested and calibrated
- undertaken to carry out the above measures on a regular basis through a surveillance process, to verify that the specifications and quality control operated by the manufacturer are being maintained.

2.4 The management system of Specialist Building Products Limited has been assessed and registered as meeting the requirements of BS EN ISO 9001 : 2008 (Certificate FM605711) by BSI.

3 Delivery and site handling

3.1 Standard 5 m lengths of boards are delivered to site in packs sealed in polythene sleeves bearing the Kestrel product marking and the BBA identification mark, incorporating the number of this Certificate. Pack quantities vary dependent upon the type of profile.

3.2 Products should be stored flat, in their protective wrapping, on a clean, level surface. Stacks must not exceed 1 m in height and should be restrained to prevent collapse. If stored externally, the packs should be kept under cover.

3.3 Care must be taken when handling PVC-U boards and trims to avoid contact with solvents or materials containing volatile organic components.

Assessment and Technical Investigations

The following is a summary of the assessment and technical investigations carried out on Kestrel PVC-UE Roofline System.

Design Considerations

4 General



4.1 The Kestrel PVC-UE Roofline System is suitable for use externally to provide a protective and decorative trim at the roofline as fascia, soffit and barge boards where timber or other conventional materials would normally be used. The system will provide adequate protection against the ingress of moisture.

4.2 The soffit ventilation products, which include the vented cellular boards, ventilator trims and over-fascia ventilator, provide a means of ventilating the roof void.

4.3 The system must be fixed only to structurally sound building substrates, at centres not exceeding 600 mm. Rafter feet and gable ladders should be adequately supported by noggings to ensure rigidity. Replacement, rather than over fixing of existing fascia, is recommended. Timber roof structures, to which the system is fixed, must be designed and/or constructed in accordance with the relevant national Building Regulations, BS EN 1995-1-1 : 2004 and its National Annex.

4.4 The system components have a similar coefficient of thermal expansion to that of conventional solid PVC-U. A 5 mm gap should be provided at the end of each board, at the joint trim (ie 10 mm between boards), to allow for movement. Care should be taken not to install the system in extremes of temperature. The recommended temperature for installation is between 5°C and 25°C.

4.5 The products meet NHBC requirements for protection against the ingress of birds, rodents or large insects.

5 Practicability of installation

The system is designed to be installed by a competent general builder, or a contractor, experienced with this type of system.

6 Ventilation



6.1 Ventilation products can contribute towards providing the necessary roof space ventilation (see Table 3). Guidance on the provision of adequate ventilation is given in the national Building Regulations and BS 5250 : 2011, Clause H.

Table 3 Application of ventilation products

Product name	Open area (mm ² per metre run)	Continuous slot (mm)
Soffit ventilator trims	25 000	25.0
Soffit ventilator 803	12 900	12.9
Soffit ventilator 903	25 800	25.8
Over-fascia ventilator UNIOFV	10 000	10.0

Cold flat roofs



6.2 The soffit ventilator 903 is suitable. For roof spans exceeding 5 m, reference should be made to BRE Report 262 : 2002.

Cold pitched roofs >10° and <15° with an LR type underlay



6.3 The over-fascia ventilator and soffit ventilator 803 are suitable. For spans exceeding 10 m or lean to or monopitch roofs, additional high level ventilation will also be required.

Cold pitched roofs >15°



6.4 The over-fascia ventilator and soffit ventilator 803 are suitable. For pitches exceeding 35°, spans exceeding 10 m or lean to or monopitch roofs, additional high level ventilation will also be required.

Warm pitched roofs



6.5 The soffit ventilator 903 and soffit ventilator trim are suitable. For lean to or monopitch roofs, additional high level ventilation will also be required.

Hybrid pitched roofs



6.6 The soffit ventilator 903 and soffit ventilator trim are suitable. Additional ventilation openings should be provided either side of any interruptions such as dormers, rooflights etc, and at high level.

6.7 When providing roof space ventilation, it is essential that the airway should not be allowed to become blocked by the loft insulation. This may be achieved by the use of a suitable BBA approved insulation retainer producing an air passage with a geometric free area at least equal to that of the soffit ventilator used.

7 Strength and stability

7.1 When installed in accordance with this Certificate, the system will withstand, without damage or permanent deflection, the wind loads likely to be encountered in the UK. In exposed locations care should be taken to ensure that all profiles are adequately fixed.

7.2 The system has adequate resistance to the hard and soft body impacts likely to occur in practice.

7.3 PVC-U gutters, as specified in BS EN 607 : 2004 may be screw-fixed directly to the 16 mm, 18 mm and 22 mm boards. Gutter bracket spacings must not exceed one metre; reduced spacings are recommended in the areas of high exposure eg Scottish Highlands. Other lightweight gutters may also be screw-fixed to the board provided the maximum bracket-loading, covered in BS EN 1462 : 2004, is not exceeded.

7.4 The 16 mm, 18 mm and 22 mm boards will support all eaves tiles in common usage in the UK (up to 10 kg load per 1 m length of fascia), provided they are installed in accordance with the requirements of this Certificate.

7.5 Apart from the exception detailed in section 7.4 of this Certificate, the fascia boards are not loadbearing and must not be used independently to support fixtures such as roof tiles, other roof structure components or television aerials. Suitably fixed telephone wires and power cables may be run along the boards but the main brackets for these services should be fixed through the fascia to structurally sound timber.

8 Performance in relation to fire

8.1 When tested in accordance with BS 476-7 : 1987 the 22 mm cellular board achieved a Class 1 surface spread of flame rating and the 9 mm board achieved a Class 1Y rating. When tested in accordance with BS 476-7 : 1997 the 16 mm and 18 mm boards achieved a Class 1 rating.

8.2 On exposure to fire PVC-U tends to char and may fall away. The spread of flame along its surface is limited. It is unlikely that the roof trim system will significantly affect the overall fire performance of any roof in which it is installed.

8.3 Where it is normal practice to carry the eaves box over, between dwellings, it is important that the box is fire-stopped at compartment walls.

9 Maintenance



9.1 The system can be cleaned by washing with water and mild detergent. Solvent-based cleaners must not be used. For the removal of more resistant stains, the Certificate holder's advice must be sought. The material can be cut and drilled, using normal woodworking tools, if repairs are required.

9.2 The dimensions of the slots in the ventilation products are such that the risk of blockage is limited. However, blockage by insects and debris would impair their performance as vents and they should be examined periodically and cleared if necessary.

9.3 As with all PVC products, paint can adversely affect the impact strength of the cellular PVC-U sections, and the application of dark colours could lead to a risk of thermal distortion. Therefore paint must not be applied.

10 Durability



10.1 Accelerated weathering tests indicate that the products are as durable as conventional solid PVC-U and the boards will retain adequate impact resistance for a period in excess of 35 years.

10.2 The system will retain its decorative function for the service life of the product with only minor changes in surface appearance.

10.3 Where the timber substrate is preservative treated with copper/chrome/boron, care must be taken to ensure that sufficient time is allowed for complete fixation of the preservative (approximately seven days) to avoid corrosion of screws and nails used to fix the components.

11 Reuse and recyclability

The PVC-U and PVC-UE profile materials can be recycled.

Installation

12 General

12.1 Installation of the Kestrel PVC-UE Roofline System must be carried out in accordance with the Certificate holder's instructions and the requirements of this Certificate (see Figure 4).

Figure 4 Typical installation details

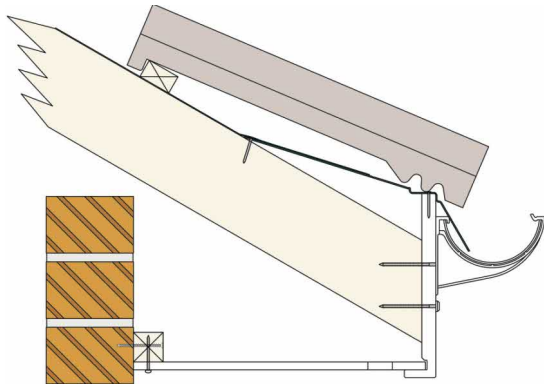

K16 fascia and 9 mm vented soffit

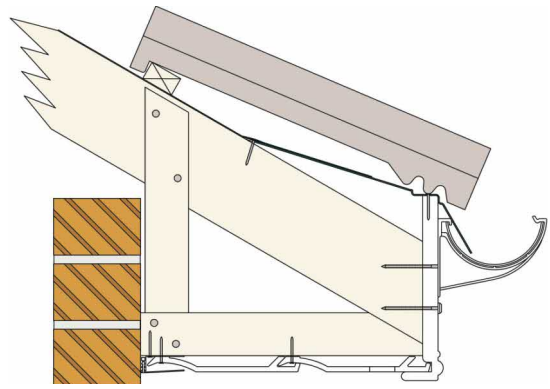

018 fascia and vented cladding

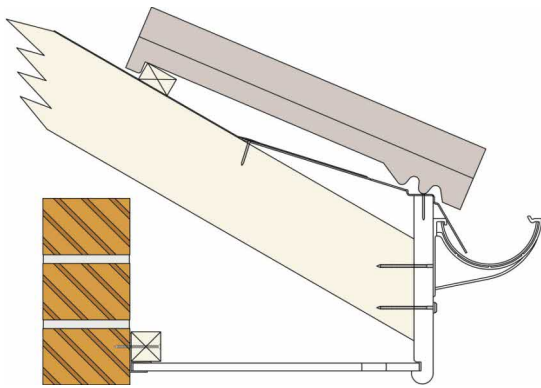

K22 fascia and 9 mm vented soffit

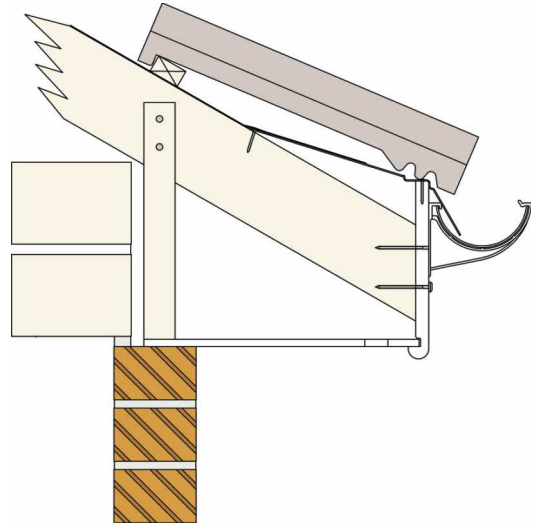

KB16 fascia and Over Fascia Ventilator

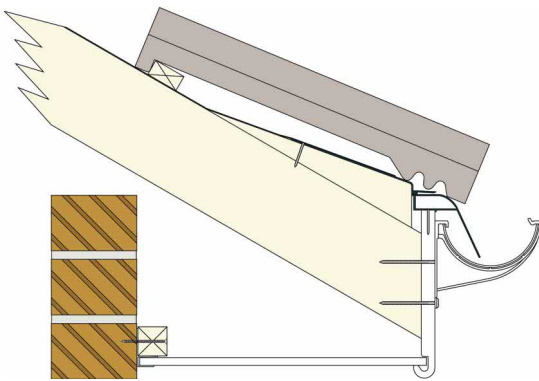

KB16 fascia and over fascia ventilator

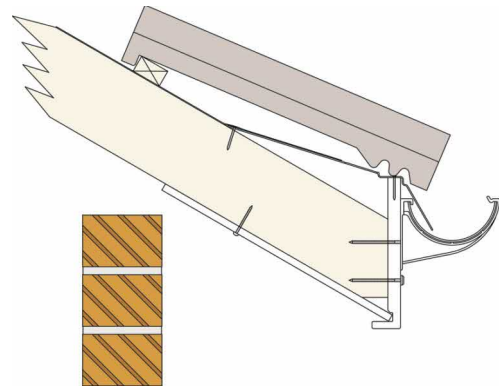

K16 fascia and 9 mm inclined soffit

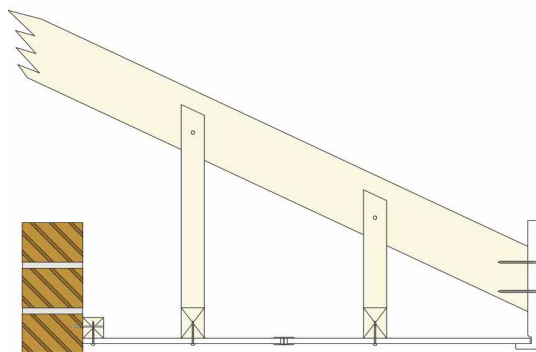

additional support

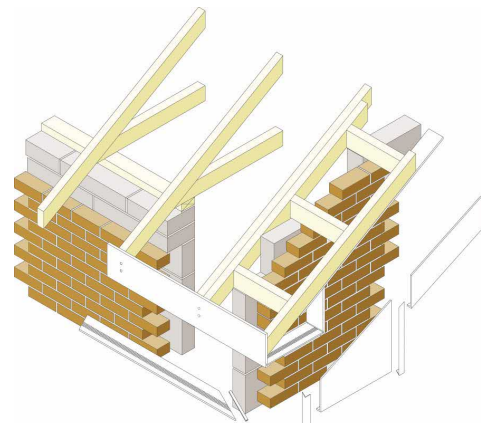

box end construction

Figure 5 Typical joint details

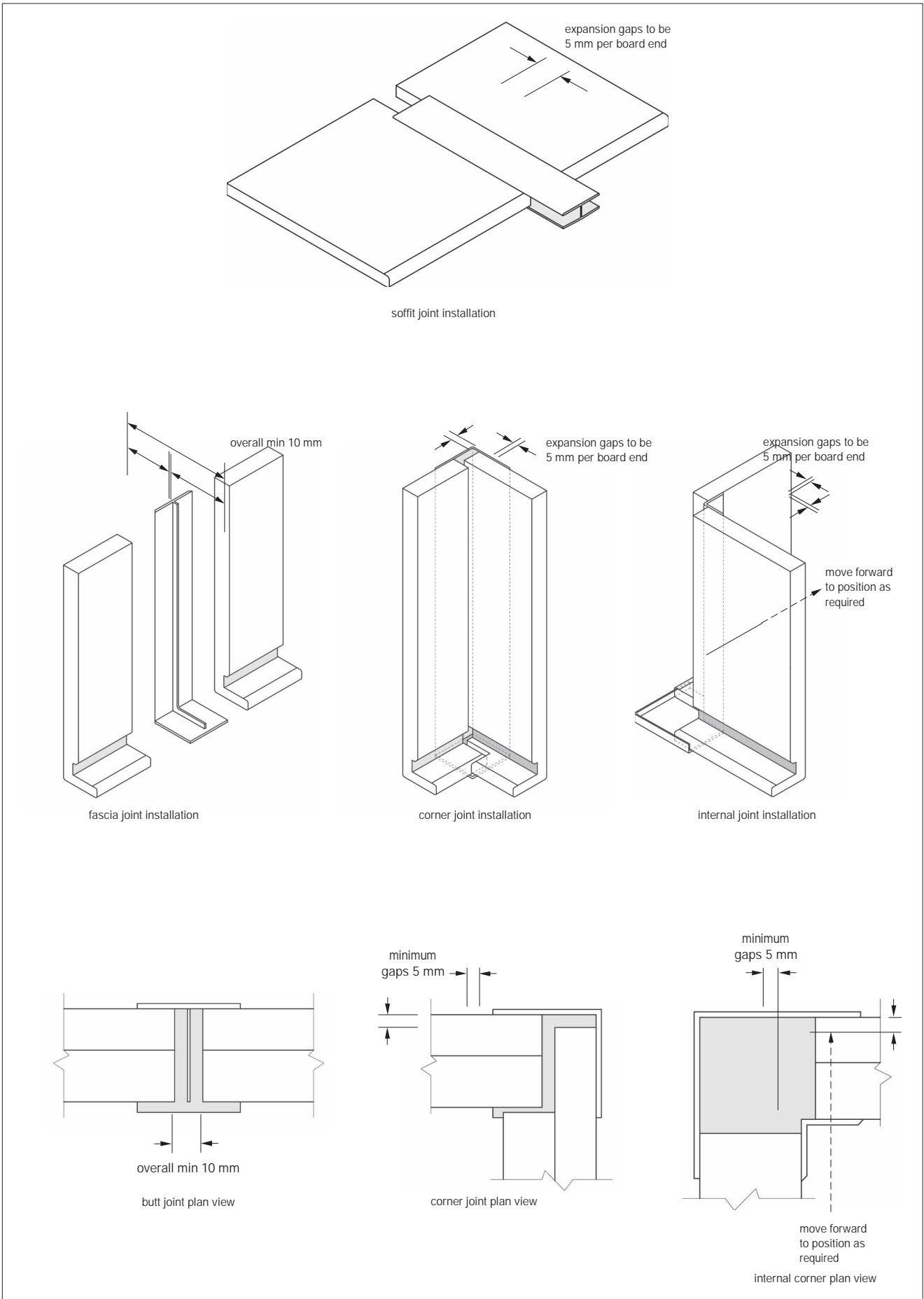

12.2 The components of the system are worked using normal woodworking tools for cutting, drilling and shaping. Handsaws should have a fine-toothed blade. Hand-held and bench-mounted power tools with a carbide-tipped blade should be run at speeds similar to, or higher than, those normally used for timber.

12.3 When using power tools to cut or shape the components, eye protection and a coarse particle dust mask should be used.

12.4 Fascia, soffit and barge boards should be fixed to preservative-treated, structurally sound, solid timbers at centres not exceeding 600 mm, using the fixings specified by the Certificate holder.

12.5 Existing support timbers should be checked for soundness and, where necessary, replaced.

12.6 Sarking felt should be checked to ensure that it is in good condition and extends onto the verge rafter and over the fascia and into the gutter at the eaves. A continuous fillet, or eaves protection system should be installed at the eaves to prevent the felt sagging between the rafters. Damaged or worn felt should be replaced in accordance with good practice.

12.7 Normal precautions should be taken when working at roof level. The use of protective goggles when cutting and nailing is recommended.

12.8 Ventilated boards should be selected and installed so that the roof ventilation conforms to the relevant Building Regulations.

12.9 The 16 mm, 18 mm and 22 mm fascia boards may be used directly to support PVC-U and other lightweight gutters (see section 7.3 of this Certificate). Other components of the system are not loadbearing (see section 7.5 of this Certificate).

12.10 The 16 mm, 18 mm and 22 mm boards may be used to support eaves tiles (see section 7.4 of this Certificate). In certain geographical/topographical locations the eaves tiles will need to be restrained in order to resist wind uplift. Guidance on this fixing should be sought from the manufacturer of the eaves tiles.

13 Procedure

13.1 Selected boards and accessories are assembled and cut to size.

13.2 Rafter feet are cut to a line.

13.3 Noggings, soffit bearers, battens, eaves fillets, brackets and other additional timber supports are fixed to a sound substrate.

13.4 Protective films should be removed just prior to fixing by peeling off as nailing progresses along the board.

13.5 The summary for the installation details of fascia, soffit and barge boards (see sections 13.6 to 13.17 of this Certificate) should be read with reference to the typical installation diagrams shown in Figure 6.

Fascia boards

13.6 Fascia boards are fixed to rafter feet, or where relevant to support timber at centres not exceeding 600 mm using at least two fixings per rafter. For the 9 mm board, 40 mm screws or 50 mm annular ring shank nails may be used. For the 16 mm, 18 mm and 22 mm boards, either 50 mm screws or 65 mm annular ring shank nails may be used. For increased rigidity the 9 mm fascia boards must be fixed over timber backing boards using 40 mm screws or 50 mm annular ring shank nails.

13.7 Where necessary, fascia boards are joined between rafters using the appropriate joint trim. Depending on the board, the joint⁽¹⁾ may be:

- nailed joint, in which the trim is fixed to the end of one board by inserting a specified 30 mm pin through the hole provided in the spine of the trim or
- an adhesive joint, in which the trim is fixed over the joint and to the end of one board with a low modulus neutral cure silicone, after both boards are in place.

(1) In each case an expansion gap is provided between boards, equivalent to 10 mm between two boards.

13.8 An appropriate corner trim, cut to size, is used at external corners⁽¹⁾. This is an adhesive joint, in which the trim is fixed over the joint and to the end of one board with a low modulus neutral cure silicone, after both boards are in place.

(1) An expansion gap is left at the end of each board, equivalent to 5 mm per board.

13.9 Internal corner joints are covered by internal corner trims. These are fixed to the end of one board with a low modulus neutral cure silicone as described for the adhesive external corner joint in section 12.8 of this Certificate.

13.10 For the 16 mm, 18 mm and 22 mm boards, gutter brackets may be fixed directly into the board using, for each bracket, at least two 25 mm long by 4.8 mm diameter parallel thread form screws recommended by the manufacturer, ensuring that the screws penetrate the rear face of the board and that the bracket spacings do not exceed 1 m. For the 9 mm board, gutter brackets are screwed through the fascia board into the timber support.

Soffit boards

13.11 Soffit boards, fitted into or butted up against fascia boards, may be used in a variety of ways, as illustrated in Figure 4. Horizontal soffits may be fixed to battens secured to the wall, fixed to soffit bearers, or fitted into soffit channels fixed to the wall. Sloping soffits are fixed directly to the underside of rafters.

13.12 Soffit boards up to 300 mm wide may be fitted between the fascia and soffit channel without additional fixing. Otherwise soffit boards should be fixed at maximum 600 mm centres along their length and 300 mm centres across their width, using the specified 40 mm annular ring shank pins, with 30 mm cladding pins used for the soffit cladding.

13.13 Soffit ventilators may be used to provide the required ventilation to roof voids. Alternatively, soffit ventilator trims may be incorporated between soffit and fascia boards.

13.14 An H-section trim (soffit joint trim) is used to join soffit boards.

Barge boards

13.15 Barge boards are installed by fixing fascia boards to a gable ladder or noggings, using the procedure given for fascia boards.

13.16 Barge boards meeting at a ridge should be mitred to the appropriate angle, allowing 5 mm for expansion between the ends of each board. To conceal the joint a cover joint trim is fixed to the end of one board using a low modulus neutral cure silicone. Further low modulus neutral cure silicone sealant may be applied between the ends of the boards as an additional fixing.

13.17 Box ends are constructed from fascia board and trims to suit the roof pitch and overhang requirement. Any timber framework required in the construction of the box end must be preservative treated.

Over fascia ventilator

13.18 The Over Fascia Ventilator is fixed to the top of the fascia using 30 mm stainless steel pins at maximum 200 mm centres. This is achieved by unclipping the two sections to gain access to the ventilation channel.

13.19 A tilting fillet should be used to provide support to the ventilator.

13.20 Roofing felt should overlap the ventilator felt support by a minimum of 125 mm.

13.21 An optional bird guard can be secured by pushing the guard into the bird guard channel but this product has not been assessed by the BBA.

Technical Investigations

14 Tests

14.1 Tests were carried out on the cellular boards to determine impact strength.

14.2 As part of the original assessment, tests were carried out on the cellular boards and trims to determine:

- thickness of layers
- Vicat softening point
- density
- weight per linear metre
- ash content
- tensile strength/elongation
- flexural strength and modulus of elasticity
- dimensional stability
- impact strength, dehydrochlorination (DHC) and appearance after UV ageing
- impact strength, dehydrochlorination (DHC) and appearance after heat ageing
- impact strength, dehydrochlorination (DHC) and appearance after watersoak
- nail pull-through
- gutter fixing
- heat reversion
- acetone resistance
- stress relief
- resistance to tile and gutter loading.

15 Investigations

15.1 Permissible dynamic wind pressures were calculated from nail pull-through data.

15.2 The dimensions of the cellular boards and trims were checked.

15.3 An examination was made of existing data relating to:

- performance of product to fire
- colour stability.

15.4 The manufacturing process was examined, including the methods adopted for quality control, and details were obtained of the quality and composition of the materials used.

15.5 The practicability of installation was assessed.

15.6 An assessment was made of the acceptability of soffit ventilators in satisfying ventilation requirements.

15.7 The compatibility and efficacy of the sealants specified for use with the product were assessed.

Bibliography

- BS 476-7 : 1987 *Fire tests on building materials and structures—Method for classification of the surface spread of flame of products*
- BS 476-7 : 1997 *Fire tests on building materials and structures—Method of test to determine the classification of the surface spread of flame of products*
- BS 5250 : 2011 *Code of practice for control of condensation in buildings*
- BS EN 607 : 2004 *Eaves gutters and fittings made of PVC-U—Definitions, requirements and testing*
- BS EN 1462 : 2004 *Brackets for eaves gutters—Requirements and testing*
- BS EN 1995-1-1 : 2004 *Eurocode 5 : Design of timber structures—General—Common rules and rules for buildings*
- NA to BS EN 1995-1-1 : 2004 : 2008 UK National Annex to *Eurocode 5: Design of timber structures. General. Common rules and rules for buildings*
- BS EN ISO 3506-1 : 2009 *Mechanical properties of corrosion-resistant stainless steel fasteners—Bolts, screws and studs*
- BS EN ISO 9001 : 2008 *Quality management systems—Requirements*
- BRE Report (BR 262 : 2002) *Thermal insulation: avoiding risks*

16 Conditions

16.1 This Certificate:

- relates only to the product/system that is named and described on the front page
- is issued only to the company, firm, organisation or person named on the front page —no other company, firm, organisation or person may hold or claim that this Certificate has been issued to them
- is valid only within the UK
- has to be read, considered and used as a whole document —it may be misleading and will be incomplete to be selective
- is copyright of the BBA
- is subject to English Law.

16.2 Publications, documents, specifications, legislation, regulations, standards and the like referenced in this Certificate are those that were current and/or deemed relevant by the BBA at the date of issue or reissue of this Certificate.

16.3 This Certificate will remain valid for an unlimited period provided that the product/system and its manufacture and/or fabrication, including all related and relevant parts and processes thereof:

- are maintained at or above the levels which have been assessed and found to be satisfactory by the BBA
- continue to be checked as and when deemed appropriate by the BBA under arrangements that it will determine
- are reviewed by the BBA as and when it considers appropriate.

16.4 The BBA has used due skill, care and diligence in preparing this Certificate, but no warranty is provided.

16.5 In issuing this Certificate, the BBA is not responsible and is excluded from any liability to any company, firm, organisation or person, for any matters arising directly or indirectly from:

- the presence or absence of any patent, intellectual property or similar rights subsisting in the product/system or any other product/system
- the right of the Certificate holder to manufacture, supply, install, maintain or market the product/system
- actual installations of the product/system, including their nature, design, methods, performance, workmanship and maintenance
- any works and constructions in which the product/system is installed, including their nature, design, methods, performance, workmanship and maintenance
- any loss or damage, including personal injury, howsoever caused by the product/system, including its manufacture, supply, installation, use, maintenance and removal
- any claims by the manufacturer relating to CE marking.

16.6 Any information relating to the manufacture, supply, installation, use, maintenance and removal of this product/system which is contained or referred to in this Certificate is the minimum required to be met when the product/system is manufactured, supplied, installed, used, maintained and removed. It does not purport in any way to restate the requirements of the Health and Safety at Work etc. Act 1974, or of any other statutory, common law or other duty which may exist at the date of issue or reissue of this Certificate; nor is conformity with such information to be taken as satisfying the requirements of the 1974 Act or of any statutory, common law or other duty of care.