

Hallway/Kitchen Door

Refer to Structural Engineers details

Painted timber glazed screen refer to drawing 22.06.04.36

Painted timber panelled doors with glazing. Ironmongery TBC

900 Kitchen Counter

Painted timber boarding to kitchen walls, design TBC

Door ID07  
1:20 Section

Painted timber boarding to depth of door reveal matching wall boarding on hallway side

Door ID07  
1:20 Elevation

Kitchen/Pantry Door

1981

900 Kitchen Counter

Door ID10  
1:20 Section

Door ID10  
1:20 Elevation

Provide fabrication drawings for sign off prior to manufacture

Side panel, upper level glazed. Fixed in place

Side panel, upper level glazed, paint finish. Opens like half leaf

Slim panelled door with glazing, Ironmongery TBC Paint finish

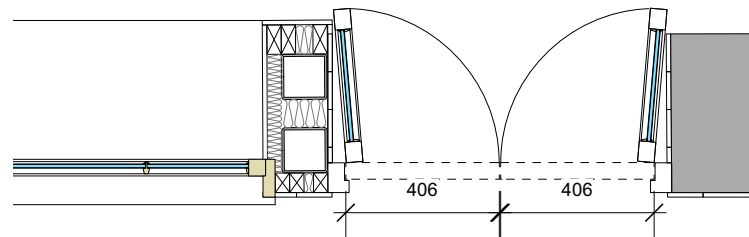

Door ID07  
1:20 Plan

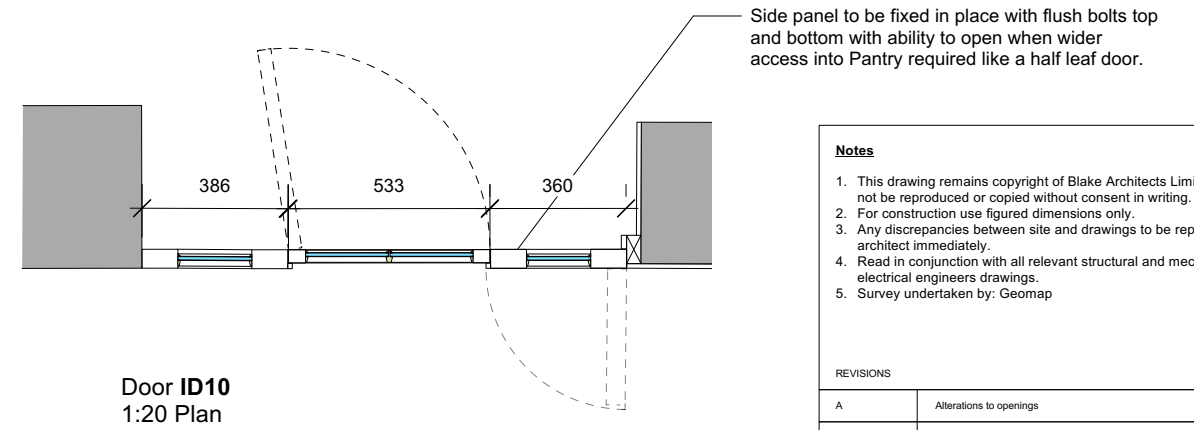

Door ID10  
1:20 Plan

Note: doors previously accepted. Drawing shows addition of window/screen opening adjacent. Details for screen on separate drawing.

Note: Fixed glazed side screen previously accepted. Drawing shows addition of small door and opening side panel.

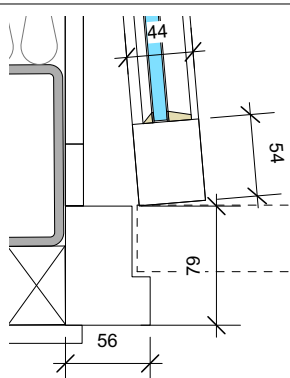

Door ID07  
1:5 Plan detail Jamb

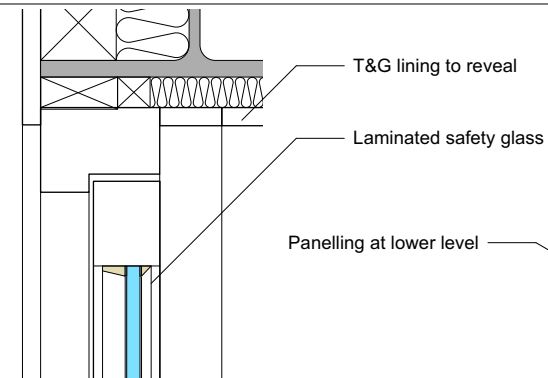

Door ID07  
1:5 Section detail Head

Panelling at lower level

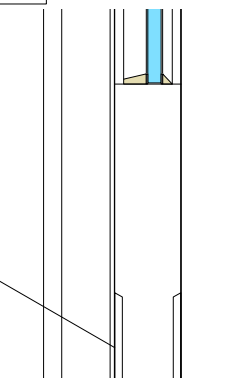

Door ID07 & ID10  
1:5 Section detail Mid Door

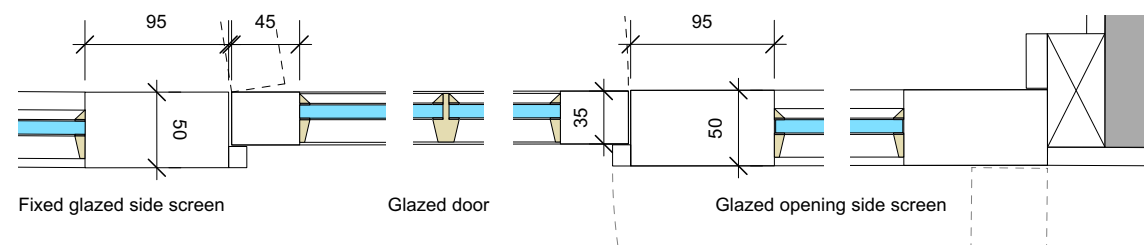

Door ID10  
1:5 Plan details

- Notes**
1. This drawing remains copyright of Blake Architects Limited and may not be reproduced or copied without consent in writing.
  2. For construction use figured dimensions only.
  3. Any discrepancies between site and drawings to be reported to the architect immediately.
  4. Read in conjunction with all relevant structural and mechanical & electrical engineers drawings.
  5. Survey undertaken by: Geomap

REVISIONS

A	Alterations to openings

PROJECT Littons, Naunton

ADDRESS Littons, Church Lane, Naunton, Gloucestershire, GL54 3AT

**Blake Architects Limited**  
1 Coves Barn, Winstone Gloucestershire. GL7 7JZ  
[t] 01285 841407 [e] mail@blakearchitects.co.uk  
www.blakearchitects.co.uk

TITLE Proposed Joinery:  
Internal Doors

DRAWING NUMBER 22.06.04.32

STATUS Stage 4

DRAWN	CHECKED	DATE	SCALE	REVISION
GY	JN	16.05.23	1:20 @ A3	A