

Provide fabrication drawings for sign off prior to manufacture

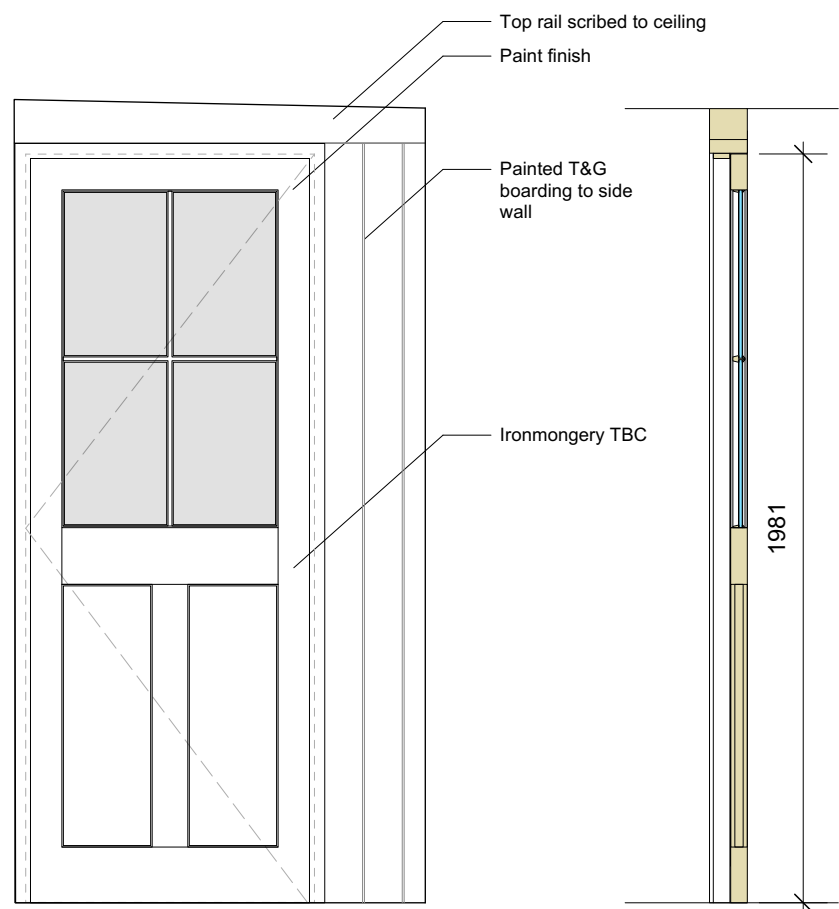

Door to Office D04  
1:20 Elevation (Hallway side)

Door to Office D04  
1:20 Section (through door)

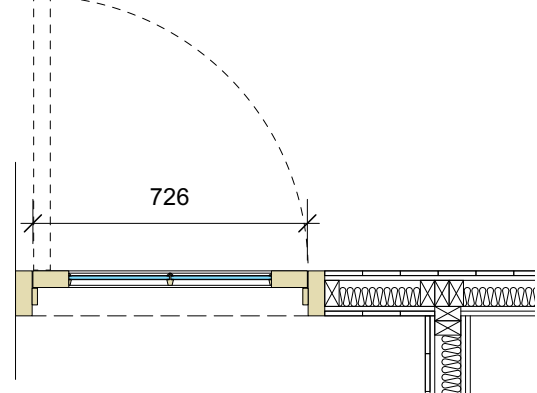

Door to Office D04  
1:20 Plan

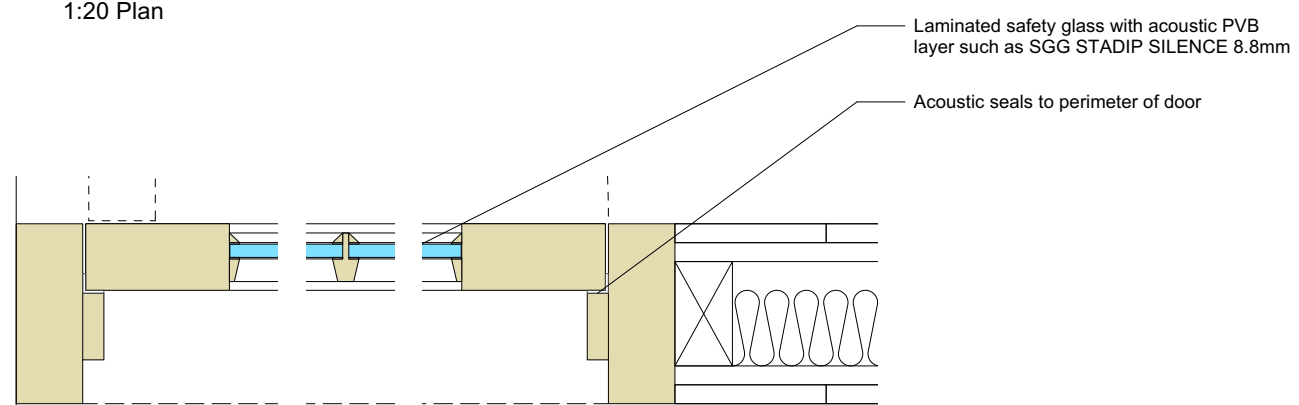

Door to Office D04  
1:5 Plan Details

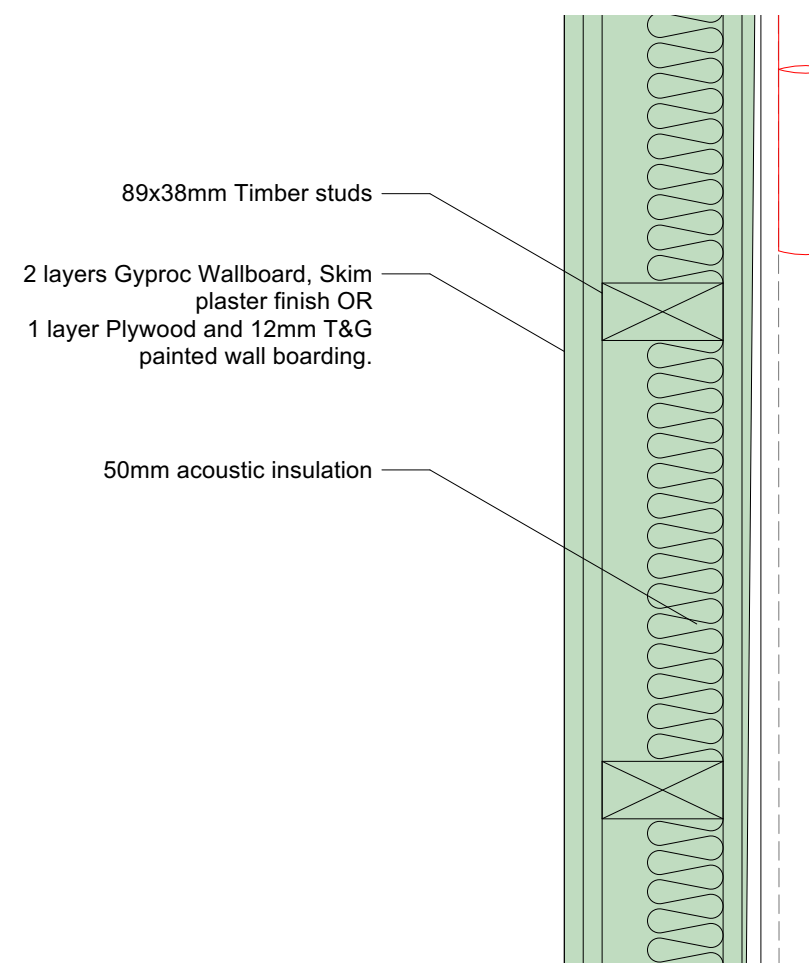

New Internal Wall Partitions  
Plan Details 1:5

- Notes**
1. This drawing remains copyright of Blake Architects Limited and may not be reproduced or copied without consent in writing.
  2. For construction use figured dimensions only.
  3. Any discrepancies between site and drawings to be reported to the architect immediately.
  4. Read in conjunction with all relevant structural and mechanical & electrical engineers drawings.
  5. Survey undertaken by: Geomap

REVISIONS

A	Glazed side screens removed from Office Door. T&G timber boarding to partition walls added

PROJECT Littons, Naunton

ADDRESS Littons, Church Lane, Naunton, Gloucestershire, GL54 3AT

**Blake Architects Limited**  
1 Coves Barn, Winstone Gloucestershire. GL7 7JZ  
[t] 01285 841407 [e] mail@blakearchitects.co.uk  
www.blakearchitects.co.uk

TITLE Proposed Joinery:  
Office Door and Screens  
& New Wall Partitions

DRAWING NUMBER 22.06.04.30

STATUS Stage 4

DRAWN	CHECKED	DATE	SCALE	REVISION
GY	JN	16.05.23	1:20 @ A3	A