

IMPORTANT TO TRANSFER ANY COVER LOADS THROUGH TO BACKFILL i.e. CONCRETE TO BE FREE OF ANY VOIDS UNDER G.R.P. TOP FLANGE.

SCRAP VIEW

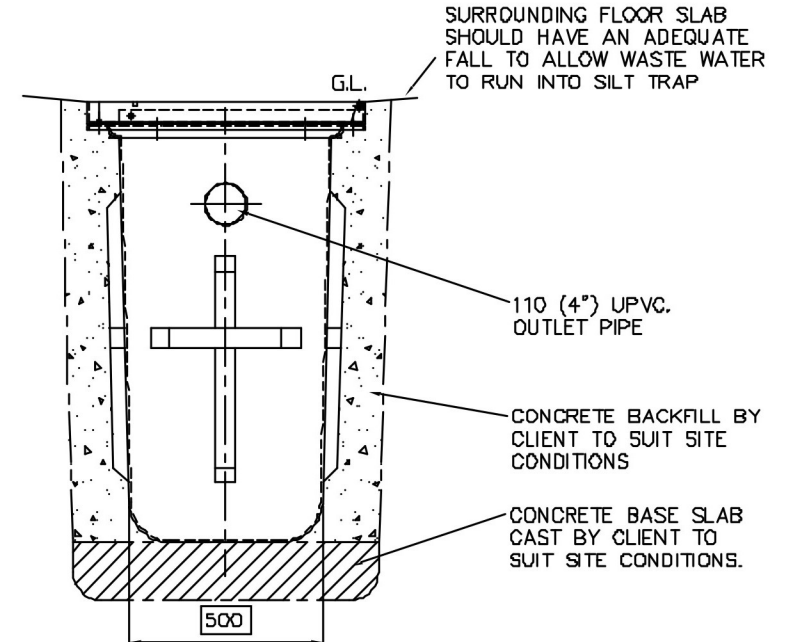
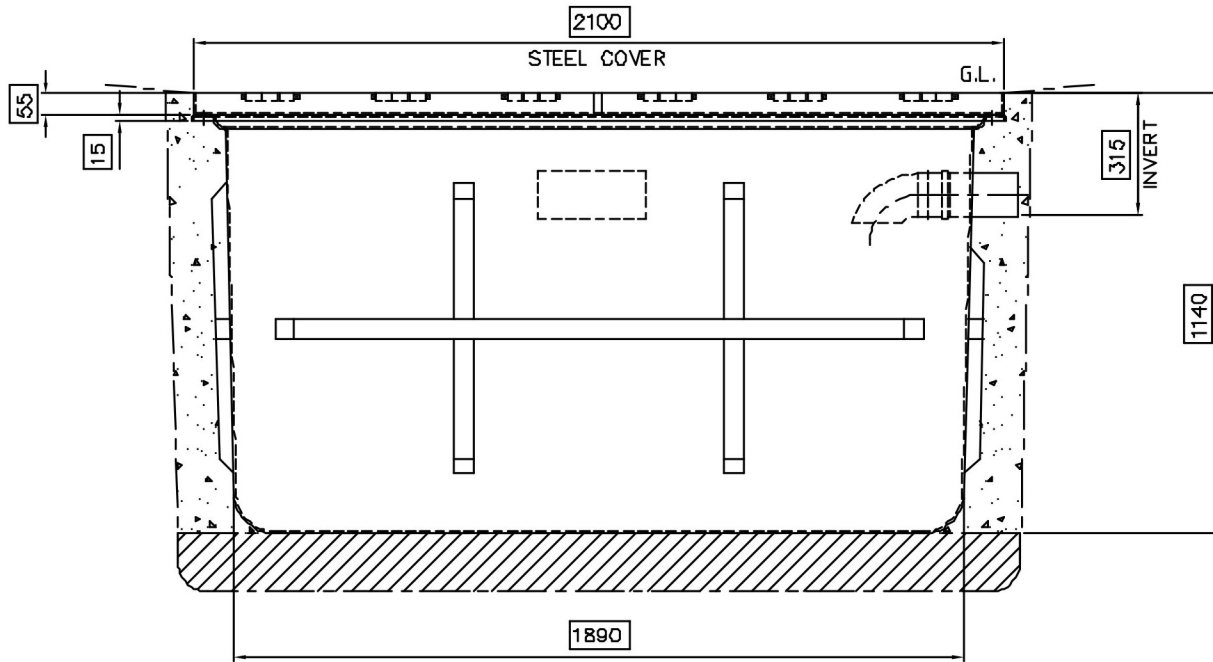

SURROUNDING FLOOR SLAB SHOULD HAVE AN ADEQUATE FALL TO ALLOW WASTE WATER TO RUN INTO SILT TRAP

110 (4") UPVC. OUTLET PIPE

CONCRETE BACKFILL BY CLIENT TO SUIT SITE CONDITIONS

CONCRETE BASE SLAB CAST BY CLIENT TO SUIT SITE CONDITIONS.

NOTES: -

1.) GALVANISED MESH COVERS (HEAVY DUTY).  
MAX LOADING - 4000Kg/200mmx200mm.

|       |          |        |                                     |
|-------|----------|--------|-------------------------------------|
| 6     | 09.11.05 | SnP    | CC306 - Note 2 Added                |
| 5     | 21.10.04 | A.L.   | NEW BORDER / DIMENSIONS ADDED       |
| 4     | 28.08.95 | S.T.   | NEW COVER / FRAME ASSEMBLY          |
| 3     | 15.11.94 | J.A.H. | CORRECT COVER SHOWN                 |
| 2     | 07.02.92 | R.F.M. | UPDATED TO SHOW INSTALLATION DETAIL |
| 1     | 30.07.91 | M.P.L. | INITIAL ISSUE                       |
| ISSUE | DATE     | DRAWN  | MODIFICATION                        |

ALL DIMENSIONS ARE IN MILLIMETRES - DO NOT SCALE

CAR WASH  
SILT TRAP  
CUSTOMER  
DRAWING

SCALE 1:10 SHEET SIZE A2

DRAWING No. 800341 ISSUE 6



THIRD ANGLE PROJECTION

