

LANDSCAPE SPECIFICATION

SITE PREPARATION

Topsail
Existing topsail shall be stripped before building works begin. Imported topsail shall be to BS3882: 2015 Specification for Topsail. Topsail shall be multi-purpose grade, of medium texture, with a high proportion of fertile loamy material. It shall be free from subsoil, rubbish, rubble, contamination, roots of perennial weeds and other materials injurious to plant growth. The maximum stone content of the soil shall be 20%, with the maximum size of stone 25mm in any one dimension. All topsail shall be stacked in heaps, not exceeding 2m high. During storage, topsail heaps shall be kept free from compaction, contamination and weeds to BS3882: 2015. Stripped and stored topsail for reuse on site to be tested to BS3882: 2015 certification, soil to be improved to meet standards prior to reuse if required.

Excavation
Excavation shall NOT be undertaken with machinery within the root protection area of any existing trees or shrubs to be retained. Areas requiring excavation under existing trees are to be hand dug with an arboriculturalist present to oversee the work. Unless otherwise indicated areas to be planted / seeded shall be cleared of all surface rubbish and excavated to the dimensions below finished level as follows, when the soil is not waterlogged or frozen. Ensure the location of all services is known before any excavation operations.

Tree pits: Excavated as per specified details
Shrub and hedge pit / trench: 300mm deep
Grass areas: 300mm deep
Wildflower grassland areas: Excavate to finished levels

The base of excavated areas shall be forked or otherwise cultivated to a depth of 150mm to facilitate drainage and all bricks, stones and other debris, etc. over 75mm in any one dimension shall be removed. Similarly, areas trafficked by construction vehicles shall be ripped to a depth of 150-300mm to relieve compaction.

Backfilling with Subsoil
Where excavated areas are lower than the required depths, excavations shall be backfilled with selected subsoil and lightly consolidated to make up levels. Selected subsoil shall be friable, second quality topsail or similar and be free of rubbish, roots, stones over 75mm in any one dimension, perennial weeds or other materials injurious to plant growth to BS8601: 2013.

Backfilling with Topsoil
Tree, shrub and hedge pit / trench excavations shall be backfilled, in layers, with clean topsail (as specified above) thoroughly mixed with planting compost e.g. 'Melcourt Topgrow' compost at a rate of 20 litres/m². An approved tree and shrub fertilizer shall be added to topsail, prior to backfilling tree-pits. Grass areas (excluding wildflower grassland areas) shall be backfilled with topsail in layers of 150mm depth.

Cultivation
Prior to cultivation if planting / seeding areas are weed infested, weed growth to be trimmed, the arisings removed and re-growth treated with an approved herbicide ie Glyphosate. Treatment to be undertaken in the growing season preceding planting, at a minimum 4 weeks prior to works to allow for repeat treatment if necessary.

Cultivation shall not be undertaken within the root protection area of any trees / shrubs to be retained, without prior agreement from the Local Planning Authority. Topsail shall be cultivated by hand or machine prior to planting, with minimal compaction by machine. Cultivate to the following depths and tilth, removing all rubbish, vegetation, perennial weeds, roots, stones over 25mm in any one dimension and rake to even levels.

Planting areas: 300mm deep cultivation to medium tilth
Grass seeding areas: 150mm deep cultivation to fine tilth raked to a smooth evenly firmed bed
Turf areas: 150mm deep cultivation to medium tilth raked to a smooth evenly firmed bed
Wildflower grassland areas: 150mm deep cultivation to medium tilth raked to a smooth evenly firmed bed

Wildflower grassland areas: Where un-excavated areas are to be seeded with wildflower grassland mix the topsail shall be cultivated to turn the soil over to a depth of 300mm to bring subsoil to the surface. Elsewhere, excavated areas to be seeded with wildflower grassland mix to be backfilled to finished levels with subsoil (as above).

PLANTING

Plant Stock and Timing
Plant material and operations shall conform to BS8545 : 2014, BS 3936 Nursery Stock (Parts 1-10), BS 4428 : 1989, BS 4043 : 1989 and BS 5837 : 2012. The planting season shall be from the 1st November to the 1st March. Container grown stock may be planted outside this season if accompanied by daily watering, or as necessary to ensure healthy establishment. Planting shall not be carried out during periods of frost, drought, cold drying winds or when the soil is waterlogged or frozen.

Planting
All planting that is within the root protection area of existing trees/shrubs to be retained, shall be undertaken by hand and positions altered should tree roots be encountered, in order to avoid damage to the root system.

All plants shall be set out evenly over the areas as indicated, to the density and quantities shown. All plants shall be planted upright at the same depth as the nursery soil level and evenly spaced, leaving room for growth. All restrictive containers shall be removed with roots not twisted. Immediately following planting, all plants shall be watered-in to field capacity.

Container grown and root balled plants shall be planted in a planting pit sufficient to accommodate the plant without causing root damage, with a minimum 50mm backfill beyond the root ball extent. Plants to be firmed, watered-in and dead, damaged or lopsided branches shall be removed after planting. Bare-root plants shall be slit planted, incorporating an approved high phosphate, slow-release fertilizer.

Tree Planting and Support
Trees planted in landscape areas shall be installed as specified.

All trees to be firmed in after planting. All trees shall have irrigation / aeration system units fitted to fully surround the root ball.

Hedge Planting
Hedges shall be planted in single / triple staggered rows as per details. Dead, damaged or straggly branches shall be removed after planting. All transplants in hedge and native mixes shall be fitted with individual protection i.e. shrub shelters, spiral guards as specified, or alternatively the planting areas shall be protected with rabbit-proof fencing. All shrub shelters / spiral guards shall be black or green, adequately supported and installed to allow for expansion.

Mulching
Prior to the application of mulch the planting areas shall be completely weed free and watered sufficiently to achieve field capacity. The surface of the planting areas shall be mulched with a minimum 75mm depth layer of 15-65mm nominal particle size, dark, matured woodchip mulch, ensuring that the low branches of trees, shrubs and/or herbaceous plants are NOT smothered.

Mulch shall be an approved product and completely weed and weed seed free. The mulch shall be topped-up to maintain, after settlement, a depth of not less than 50mm. Trees in grass areas shall be planted centrally within a 1m diameter mulch bed, to be mulched to 75mm deep. The surface of mulch to be 10mm below the surface of adjacent lawn / hard surface.

GRASS AREAS

Turf
Turf shall accord with BS 3969: 1998, it shall be good quality meadow / cultivated, amenity turf free from weeds and be laid on even, prepared ground (as detailed above), during periods of suitable warm and moist weather conditions. Pre-turfing fertiliser shall be applied to manufacturer's recommendations and turf shall be laid in accordance with BS 4428: 1989.

Turf shall be laid with broken joints well-butted up, working from timber planks to avoid damaging turf when laying. Water as necessary to avoid shrinkage and achieve satisfactory establishment. Undertake good horticultural practice to ensure establishment of a healthy grass sward.

Grass Seeding
Areas of amenity grass shall be seeded with a general amenity grass mix as specified during the period March to May or September to October during periods of moist, warm weather conditions without significant wind. Pre-seeding fertiliser shall be applied to manufacturer's recommendations. Seed shall be sown on even, prepared ground (as detailed above), at a rate of 35g/m² or as specified, in two transverse operations. Lightly roll seed bed after sowing. Water as necessary to avoid shrinkage and achieve satisfactory establishment. Undertake good horticultural practice to ensure establishment of a healthy grass sward.

Wildflower Grassland Seeding
Areas of wildflower grassland shall be seeded with a wildflower grassland mix suitable for the soil type as specified, during the period March to May or September to October, during periods of suitable warm and moist weather conditions. Seed shall be sown on prepared ground (as detailed above), at a rate of 5g/m² or as specified. Lightly roll seed bed after sowing. Water as necessary to avoid shrinkage and achieve satisfactory establishment. Undertake good horticultural practice to ensure establishment of a healthy wildflower grass sward.

AFTERCARE PERIOD

Regular Visits
During the specified Aftercare Period maintenance visits shall be carried out, at least monthly from April to September and twice during the dormant season to carry out the following operations to establish healthy growing plants / grass in weed free areas: watering, firming-up, removal of litter, pest and disease control, general pruning, checking guards, ties and stakes, weed control, grass cutting and autumn tidying. All arisings shall be carted away and the site shall be left clean and tidy at all times.

Watering
All planting and grass areas shall not be allowed to dry out and shall be kept well watered during the growing season, ensuring the soil is kept moist at all times but avoiding waterlogging.

Replacement Planting
During each August within the Aftercare Period an inspection shall be made and all plants that have died, are missing, damaged or have failed to thrive, shall be noted and replaced in the following planting season.

Grass Cutting
During the first and subsequent growing seasons amenity grass shall be kept at a height of 25mm to 50mm. Any bare patches are to be resown. Selective weed control shall be undertaken as necessary once the sward is sufficiently established.

Wildflower Grassland Cutting
During the first growing season cut wildflower grassland every 2 months to a height of 40-60mm and in subsequent growing seasons cut to 40-60mm height during late March and late August / early September or as specified. All arisings shall be collected and removed from the site to avoid smothering the sward and to reduce nutrient levels. Spot treat perennial weeds with Glyphosate at the manufacturer's recommended dose rate / or hand pull.

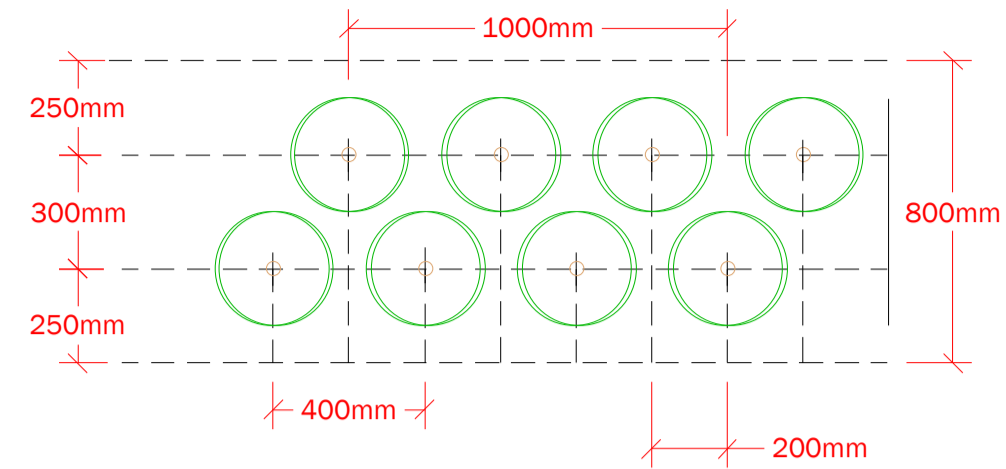

DOUBLE STAGGERED HEDGE PLANTING DETAIL;
5 per metre;
For mixed native hedging

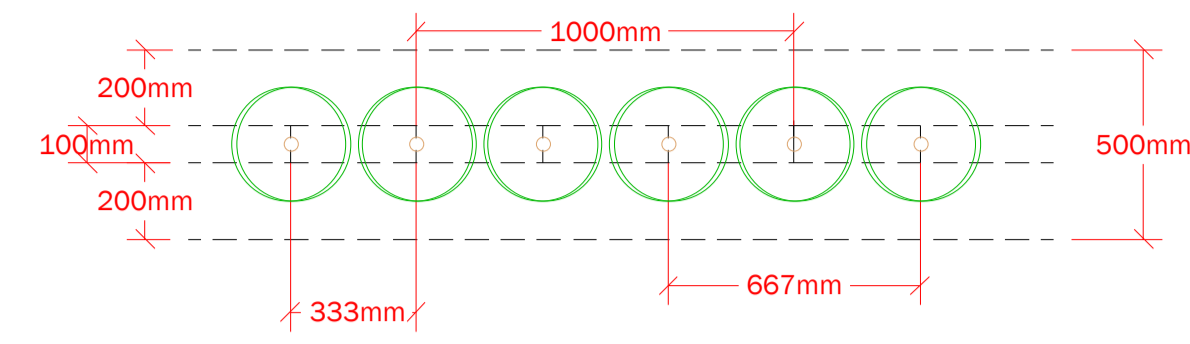

The hedge shall be planted in a single row at the above dimensions

SINGLE ROW HEDGE PLANTING DETAIL;
3 per metre;
For ornamental hedging

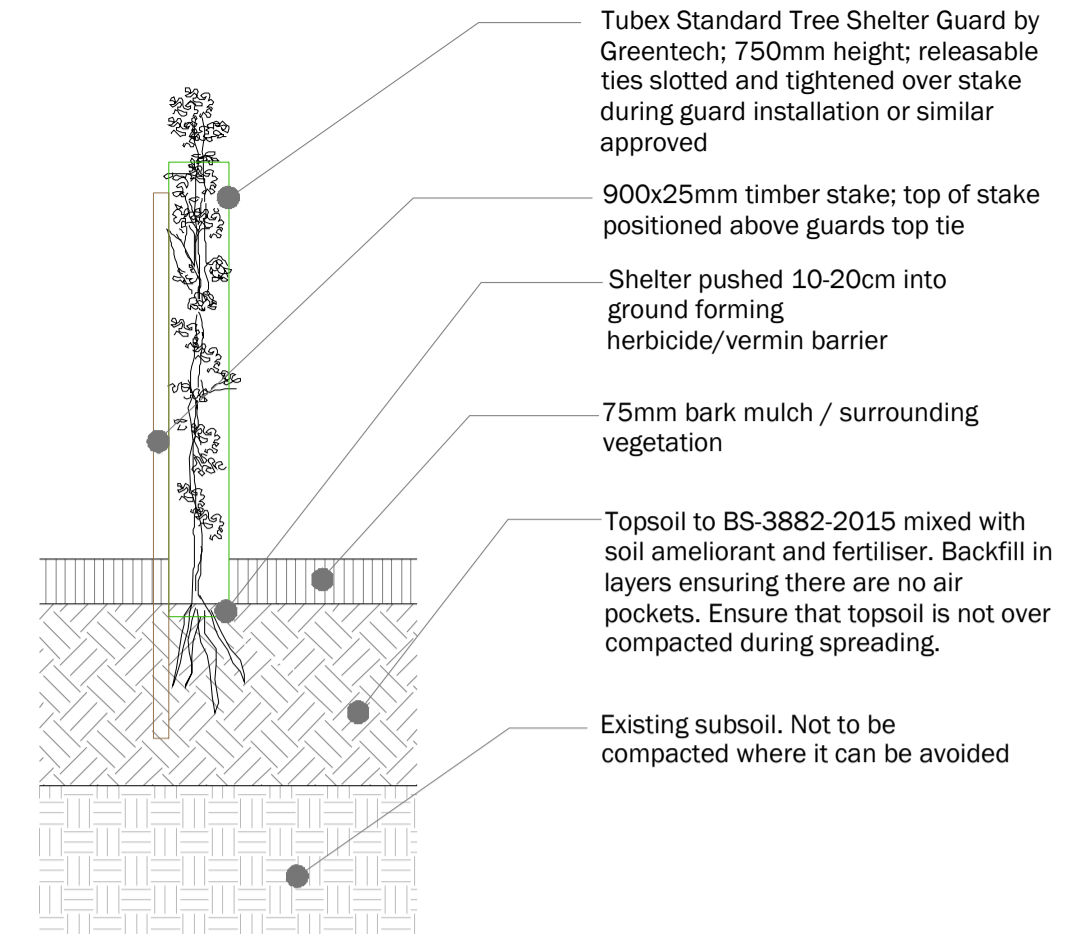

NATIVE HEDGE PLANTING DETAIL

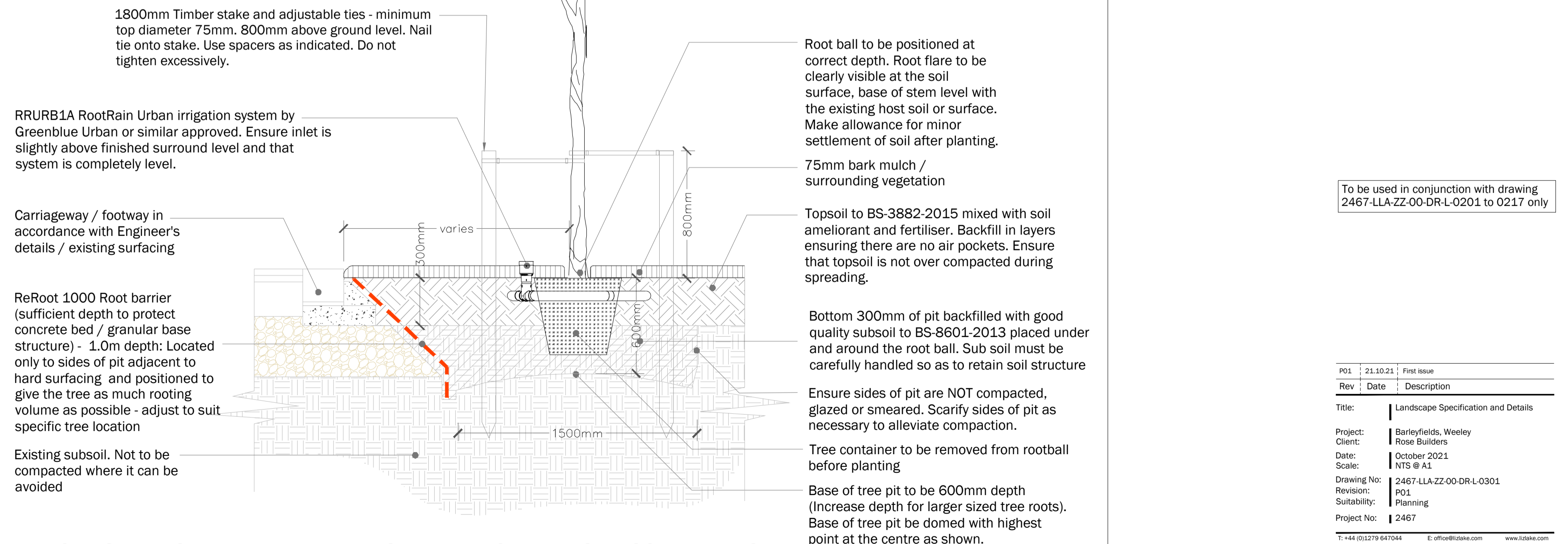

TYPICAL CLEAR STEM TREE PLANTING DETAIL FOR TREES IN CONTAINERS
Double stake fixing in soft landscape adjacent to Carriageway / footway - Not to Scale

To be used in conjunction with drawing 2467-LLA-ZZ-00-DR-L-0201 to 0217 only

PO1	21.10.21	First Issue
Rev	Date	Description
Title: Landscape Specification and Details		
Project: Barleyfields, Wexley		
Client: Rose Builders		
Date: October 2021		
Scale: NTS @ A1		
Drawing No: 2467-LLA-ZZ-00-DR-L-0301		
Revision: PO1		
Suitability: Planning		
Project No: 2467		
T: +44 (0)1279 647044 E: office@lizeke.com www.lizeke.com		
<small> COPYRIGHT © Liz Lake Associates Information contained in this drawing is confidential and may not be used for any purpose other than that intended without the written authority of Liz Lake Associates. This drawing is copyright and may not be copied except within the agreed conditions of use. BEST MATCHING Information from Ordnance Survey maps data by permission of Ordnance Survey © Crown copyright 2020. Licence No. 100001200 © Liz Lake Associates Ltd. 2021 Ordnance Survey Licence No. 0100012478. This drawing may contain information or be missing from a number of sources and its accuracy should be verified on site. </small>		
LIZ LAKE ASSOCIATES LANDSCAPE ARCHITECTS		