

IF IN DOUBT ASK

- TANK CONNECTION:**
- ORIENTATION SHOWN IN CLOCKWISE DIRECTION FROM 0° AT 12 O'CLOCK
  - ELEVATION IS CONSIDERED FROM THE TOP OF CONCRETE/ EMBEDMENT

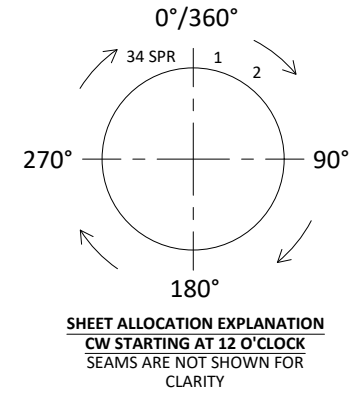

TANK CONNECTIONS TABLE					
ITEM	SIZE/TYPE	ELEVATION FROM TOP OF CONCRETE	ORIENTATION CLOCKWISE 0° AT 12 O'CLOCK	FINISH	NOTES
M1	Ø800 MANWAY	670	STANDARD SHEET	GALVANISED	ACCESS

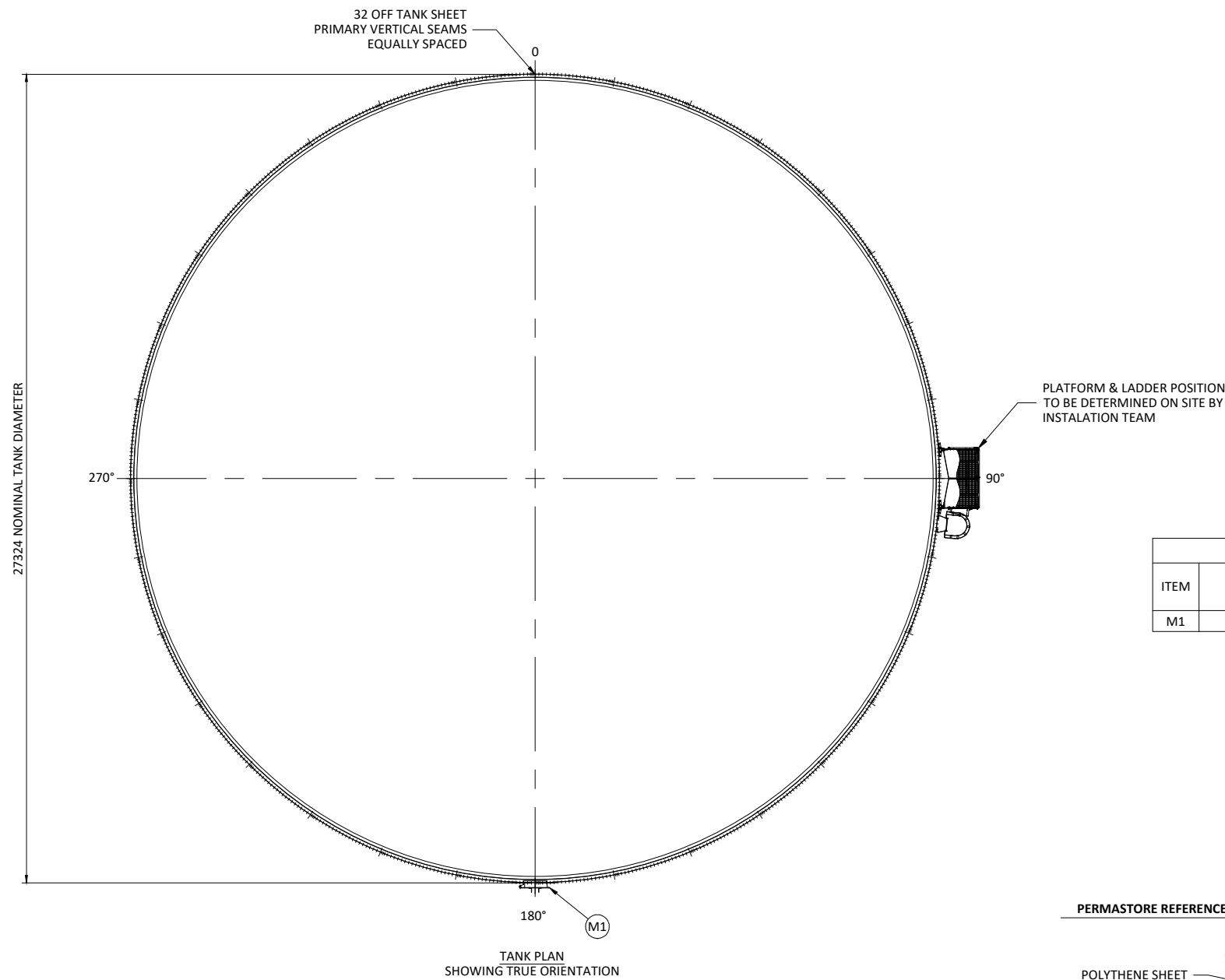
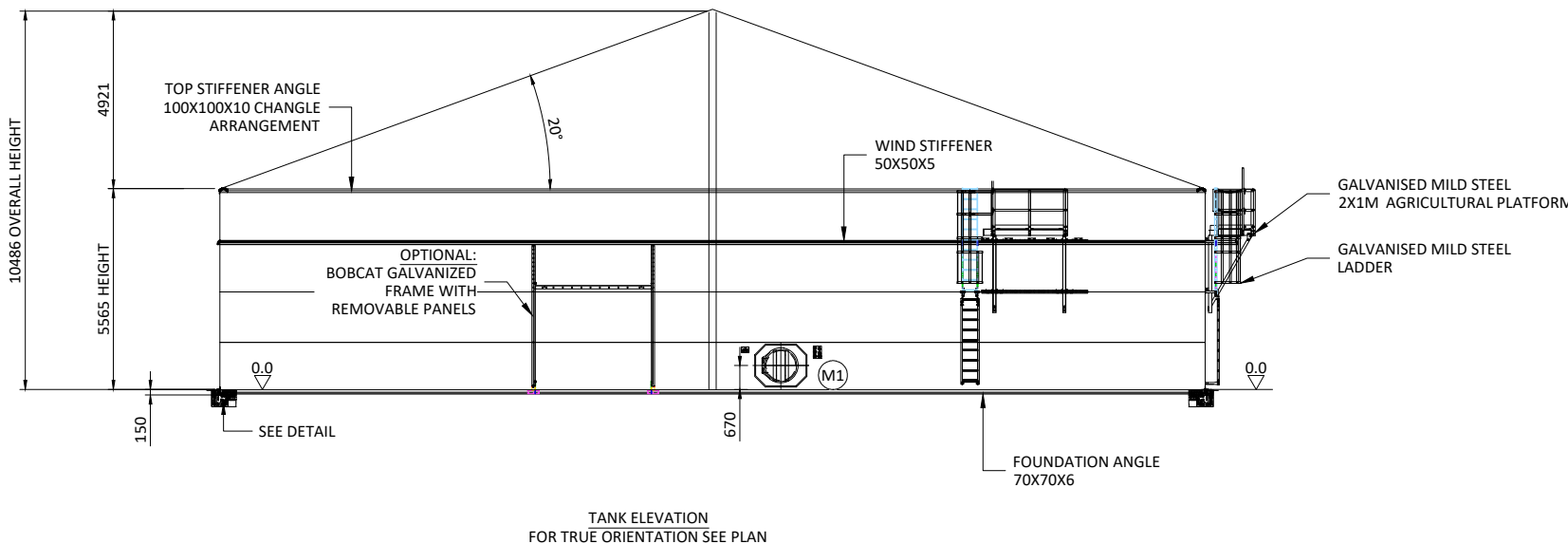
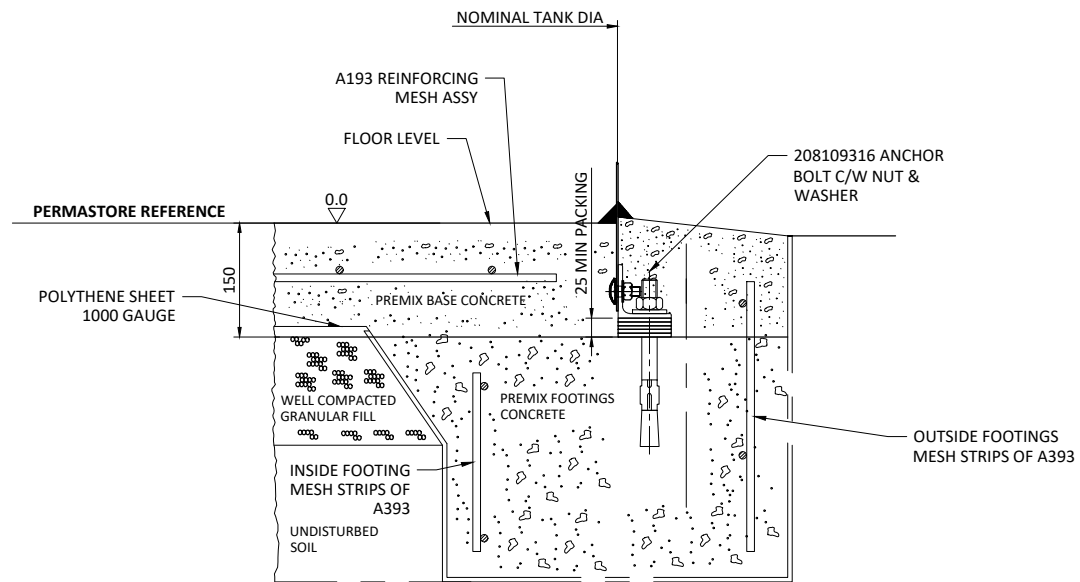

SECTION OF FOUNDATION DETAIL FOR SLURRY TANK CONCRETE BASE

TANK ELEVATION FOR TRUE ORIENTATION SEE PLAN

- DIMENSIONS :**
- ALL DIMENSIONS ARE IN MILLIMETERS
  - NOMINAL IMPERIAL EQUIVALENTS ADDED WHEN REQUIRED



Permastore Ltd  
 Eye, Suffolk  
 IP23 7HS, England  
 Tel: +44 1379 870723  
 Fax: +44 1379 870530  
 Web: www.permastore.com

THIRD ANGLE PROJECTION  
 TITLE: TANK MODEL 90-20

CLIENT: -

PROJECT REF: -

SCALE:	SHEET:
DWN NO:	-

UNCONTROLLED WHEN PRINTED

PERMASTORE® IS A REGISTERED TRADEMARK OF PERMASTORE LTD