

A - A Window Jamb Detail 1:2

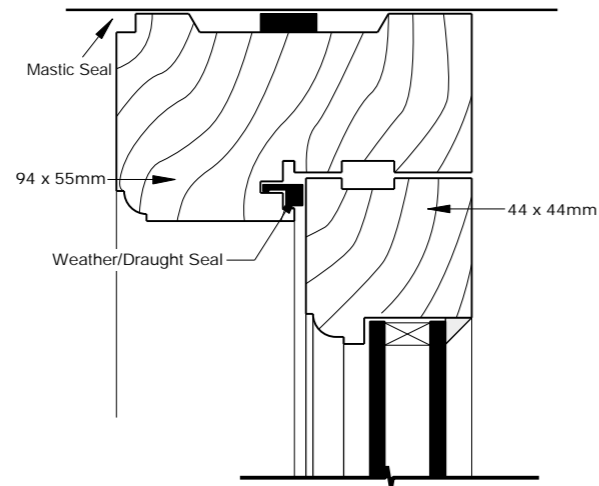

B - B Window Head Detail 1:2

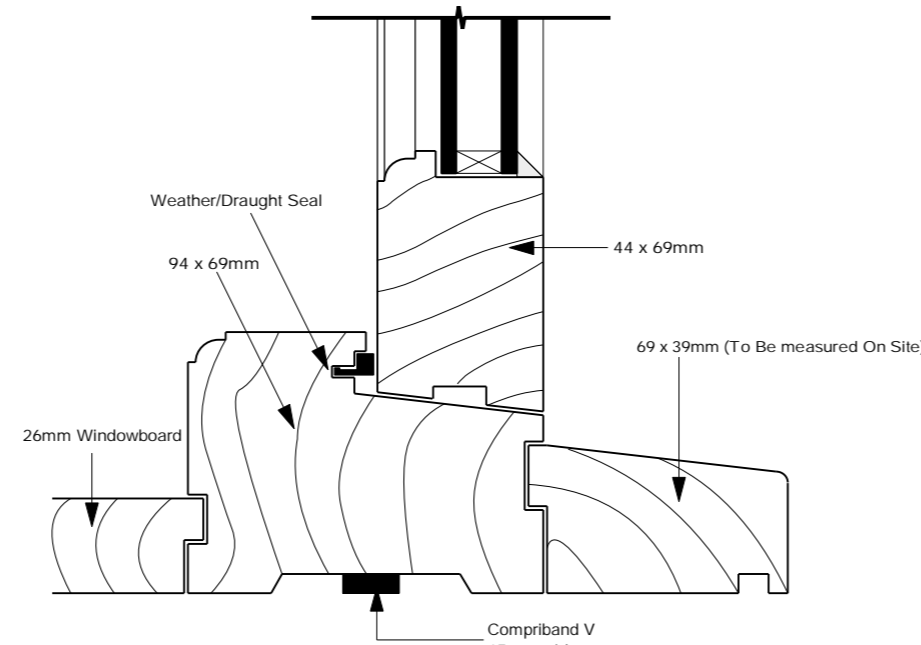

C - C Window Cill Detail 1:2

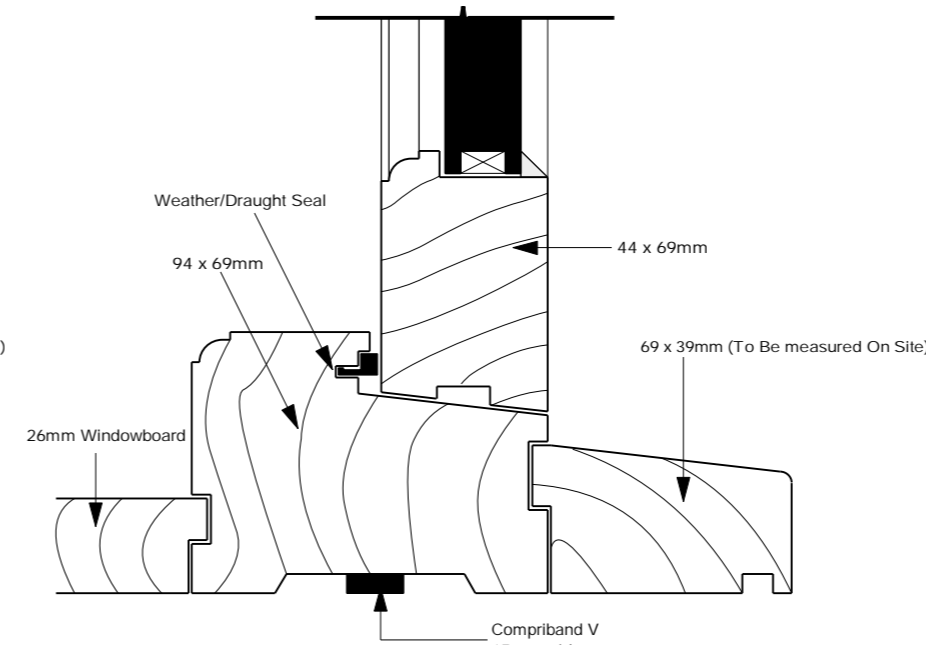

D - D Door Cill Detail 1:2

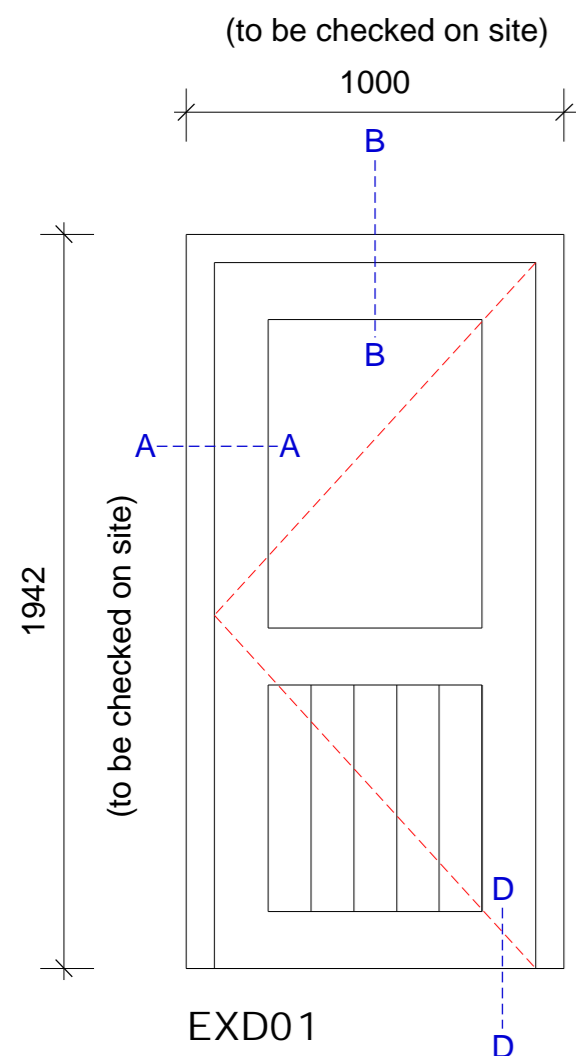

EXD01

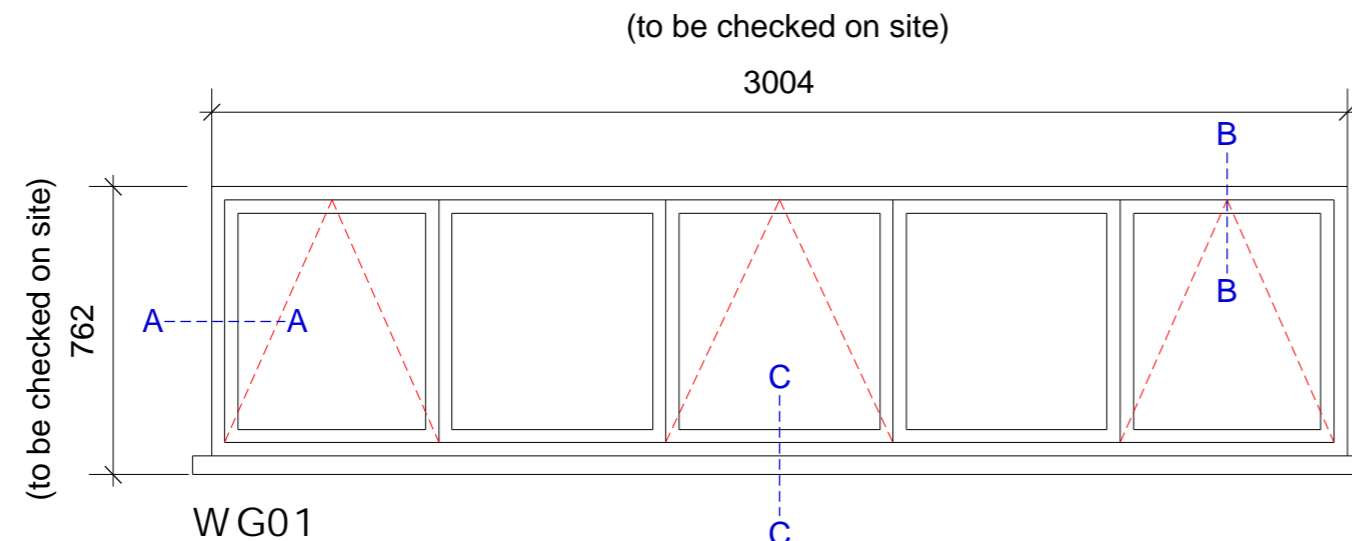

WG01

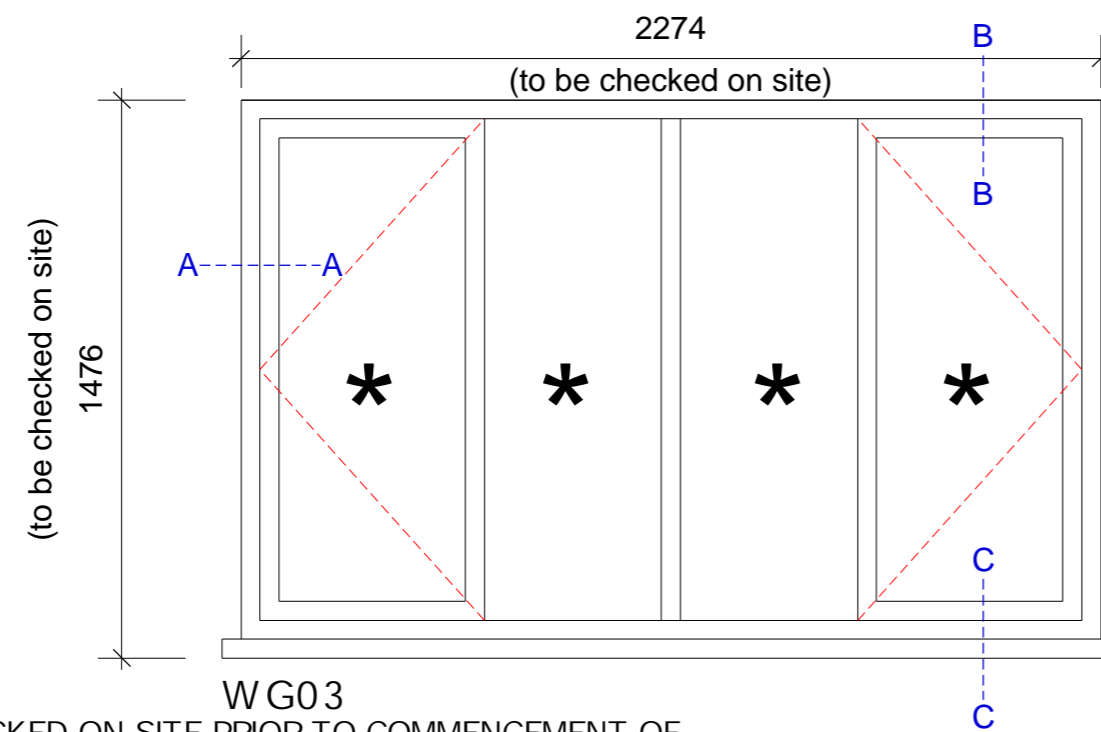

WG03

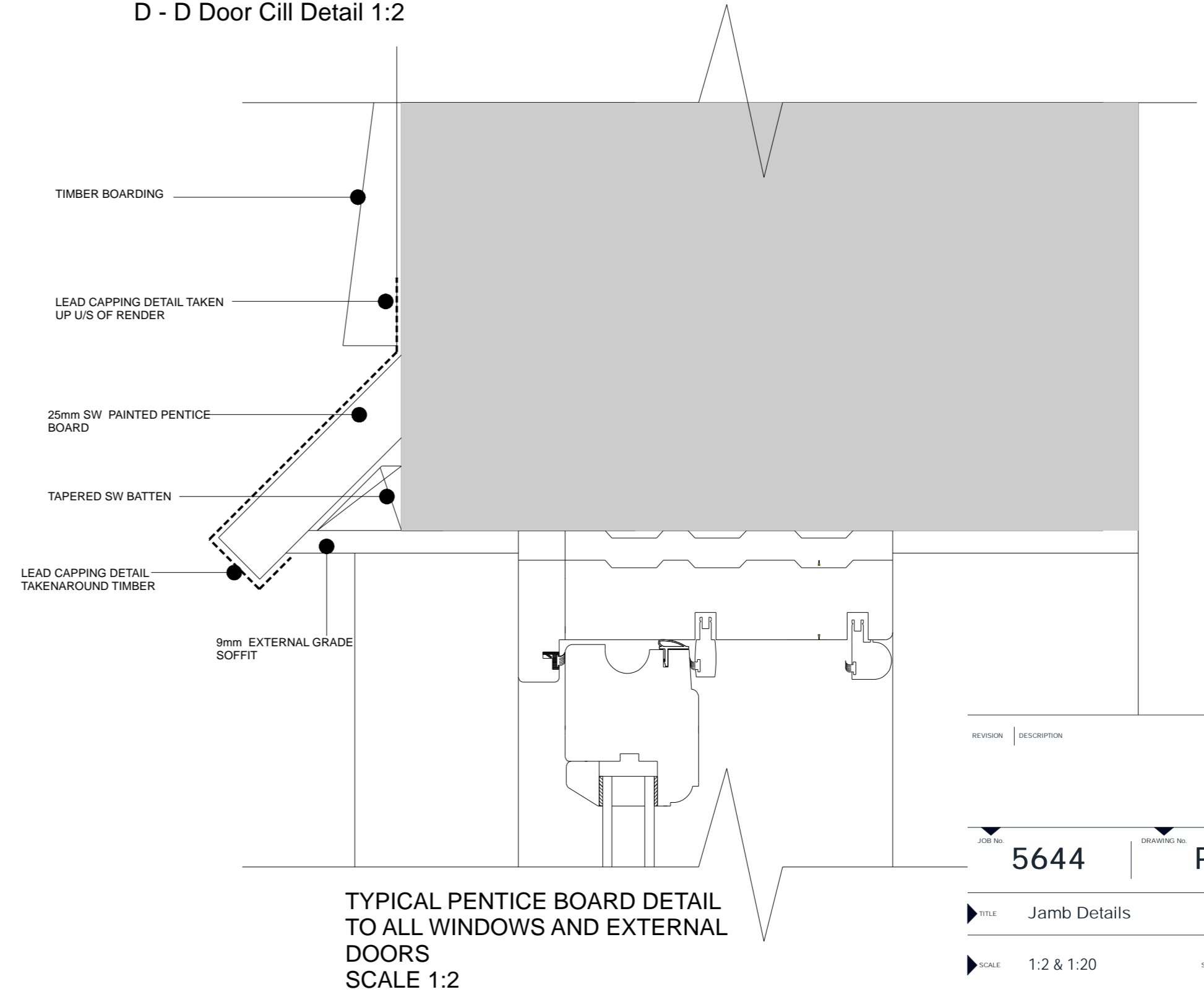

TYPICAL PENTICE BOARD DETAIL TO ALL WINDOWS AND EXTERNAL DOORS SCALE 1:2

NOTES:

- SIZES OF ALL OPENINGS TO BE CHECKED ON SITE PRIOR TO COMMENCEMENT OF FABRICATION BY THE MAIN CONTRACTOR.
- FABRICATION TO INCLUDE THE SUPPLY AND INSTALLATION OF SCHLEGEL ENGINEERING (OR SIMILAR APPROVED) DRAUGHT PROOFING SEAL'S COLOUR :BROWN.
- TIMBER SIZES INDICATED ON DETAILS ARE FINISHED SIZES.
- FABRICATION TO INCLUDE THE SUPPLY AND INSTALLATION OF BRASS/ STAINLESS STEEL CASEMENT HINGES TO OPENING LIGHTS.
- WINDOWS GENERALLY TO BE TIMBER THROUGHOUT.
- EXTERNAL DOORS GENERALLY TO BE TIMBER THROUGHOUT.
- HEAD HEIGHTS TO BOTH WINDOWS AND DOORS TO BE CHECKED ON SITE.
- WINDOWS / DOORS TO BE PURPOSE MADE.

* Indicates Safety glazing in accordance with Building Regulations Approved Document Part K (2013 edition), NHBC Standards and BS 6206.

NOTES

- ALL WORKMANSHIP SHALL BE IN ACCORDANCE WITH BS8000.
- THIS DRAWING TO BE READ IN CONJUNCTION WITH THE ARCHITECTS BUILDING REGULATIONS & CONST. NOTES DOCUMENT.
- THIS DRAWING TO BE READ IN CONJUNCTION WITH THE STRUCTURAL ENGINEERS DRAWINGS, DETAILS AND CALCULATIONS.
- THIS DRAWING TO BE READ IN CONJUNCTION WITH THE CIVIL ENGINEERS DRAWINGS, DETAILS AND CALCULATIONS.
- ALL DIMENSIONS TO BE CHECKED BY THE MAIN CONTRACTOR AND ANY DISCREPANCIES REGARDING THIS OR OTHERWISE ARE TO BE REPORTED TO THE ARCHITECT.
- ALL DIMENSIONS ARE TO STRUCTURE ONLY AND DO NOT TAKE INTO ACCOUNT FINISHES SUCH AS PLASTER OR TILES.
- MAIN CONTRACTOR IS TO OBTAIN ALL RELEVANT AUTHORITY APPROVALS AND CONSENTS WITH REGARDS TO SERVICES AND BUILDING REGULATIONS INSPECTIONS, ETC.

REVISION	DESCRIPTION	DATE	DRAWN	CHECK
----------	-------------	------	-------	-------

JOB No.	5644	DRAWING No.	PA_11	REVISION
---------	------	-------------	-------	----------

TITLE Jamb Details

SCALE 1:2 & 1:20 SHEET SIZE A1

ISSUE DATE November - 2023

AUTHOR CM CHECK CW

PROJECT Proposed Alterations and Refurbishment of Outbuilding White House, The Street, Chelsworth, Suffolk, IP7 7HU

CLIENT Dodgson, Mrs P & Davidson Mr. S

STATUS For Planning

