



This drawing is produced for the purpose of obtaining Planning / Building regulation and forms no part of any other contract



PROPOSED BAY WINDOW

PROPOSED PORCH



THE SITE



BLOCK PLAN 1: 500

© Crown copyright 2024 All rights reserved
Licence Number AC0000846597

LOCATION PLAN 1:1250

© Crown copyright 2024 All rights reserved
Licence Number AC0000846597

A3 PAPER SIZE

1: 50	0m		1m
1: 100	0m		1m
1: 500	0m		5m
1:1250	0m		10m

Alan Wilson
"Glebeland" Sands Road
The Sands
Farnham
Surrey
GU10 1LT
alanjwilson0048@gmail.com
01252 722965

Client	Title	Scales	Revisions	Drg. No.
Mr & Mrs D Collier 23 Worcester Avenue Hatch Warren Basingstoke Hampshire RG22 4PR	Proposed Front Porch & Bay Window	1: 1250 1: 500		2425006/1
Location & Block Plans				



This drawing is produced for the purpose of obtaining Planning / Building regulation and forms no part of any other contract

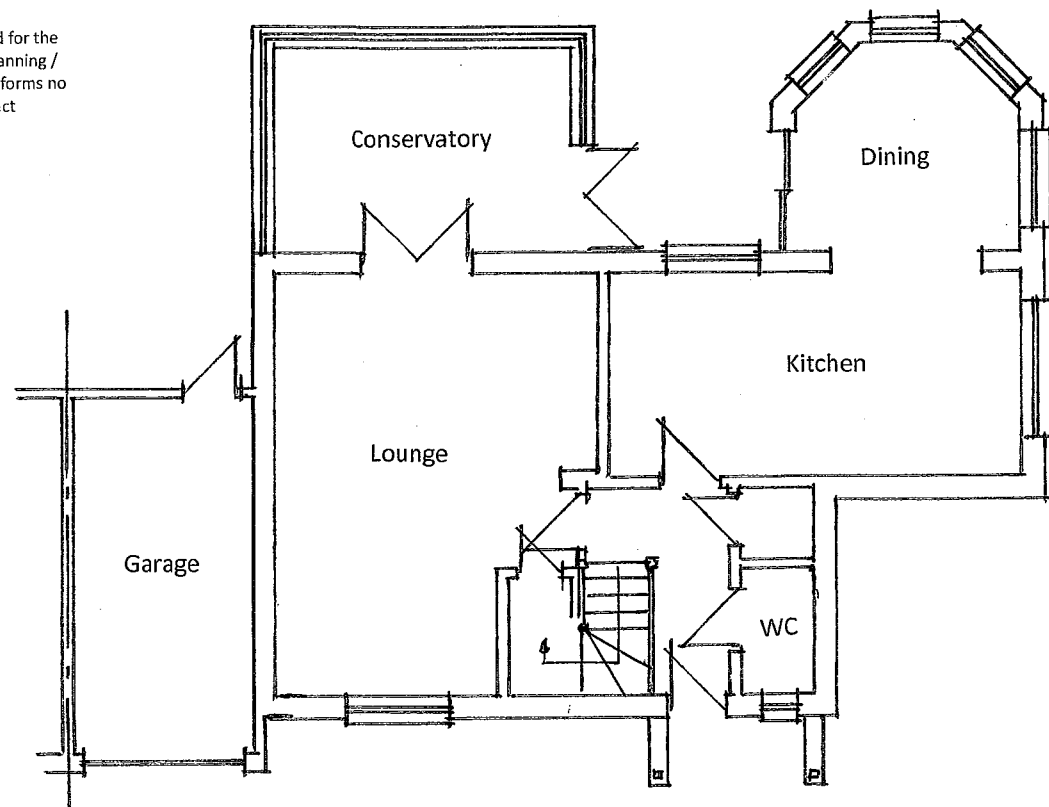

GROUND FLOOR

EXISTING FLOOR PLANS 1:100

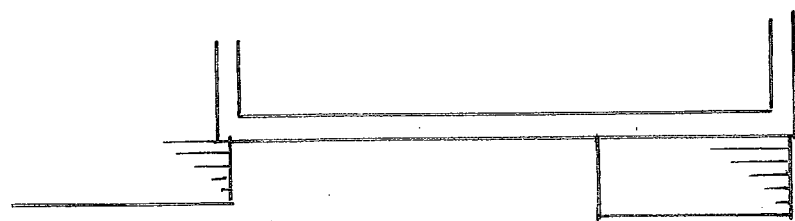

EXISTING ROOF PLAN 1:100

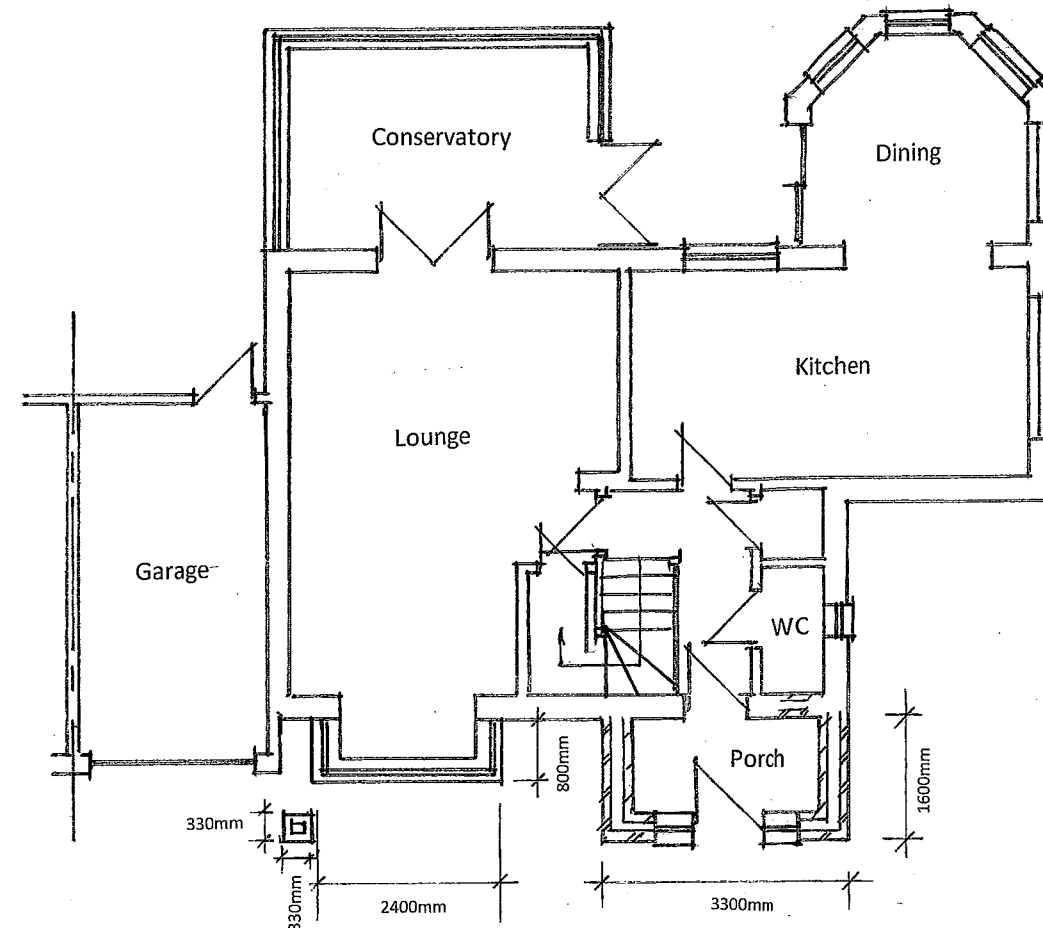

GROUND FLOOR

PROPOSED FLOOR PLANS 1:100

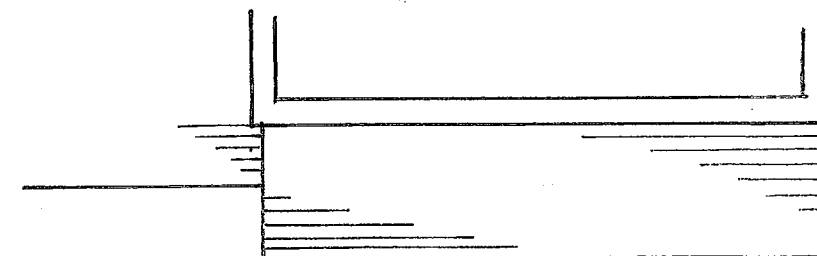

PROPOSED ROOF PLAN 1:100

Alan Wilson
 "Glebeland" Sands Road
 The Sands
 Farnham
 Surrey
 GU10 1LT
 alanjwilson0048@gmail.com
 01252 722965

A3 PAPER SIZE			
1:50	0m		1m
1:100	0m		1m
1:500	0m		5m
1:1250	0m		10m

Client	Title	Scales	Revisions	Dr. No.
Mr & Mrs D Collier 23 Worcester Avenue Hatch Warren Basingstoke Hampshire RG22 4PR	Proposed Front Porch & Bay Window	1:100		2425006/2
Existing & Proposed Plans				



This drawing is produced for the purpose of obtaining Planning / Building regulation and forms no part of any other contract

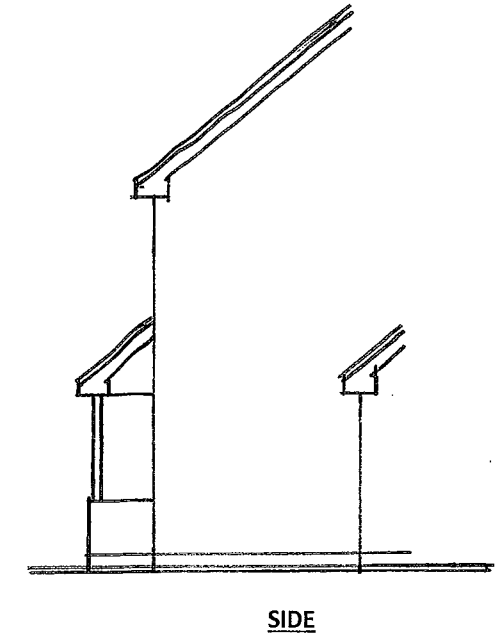
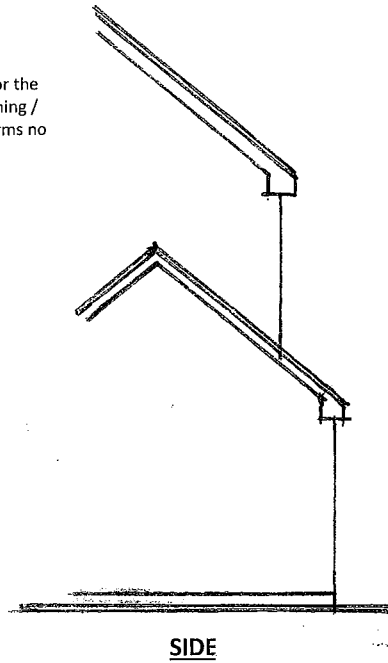

EXISTING ELEVATIONS 1:100

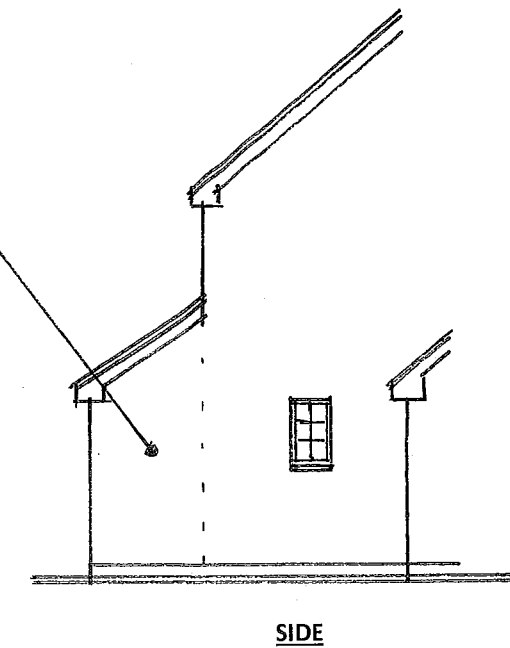
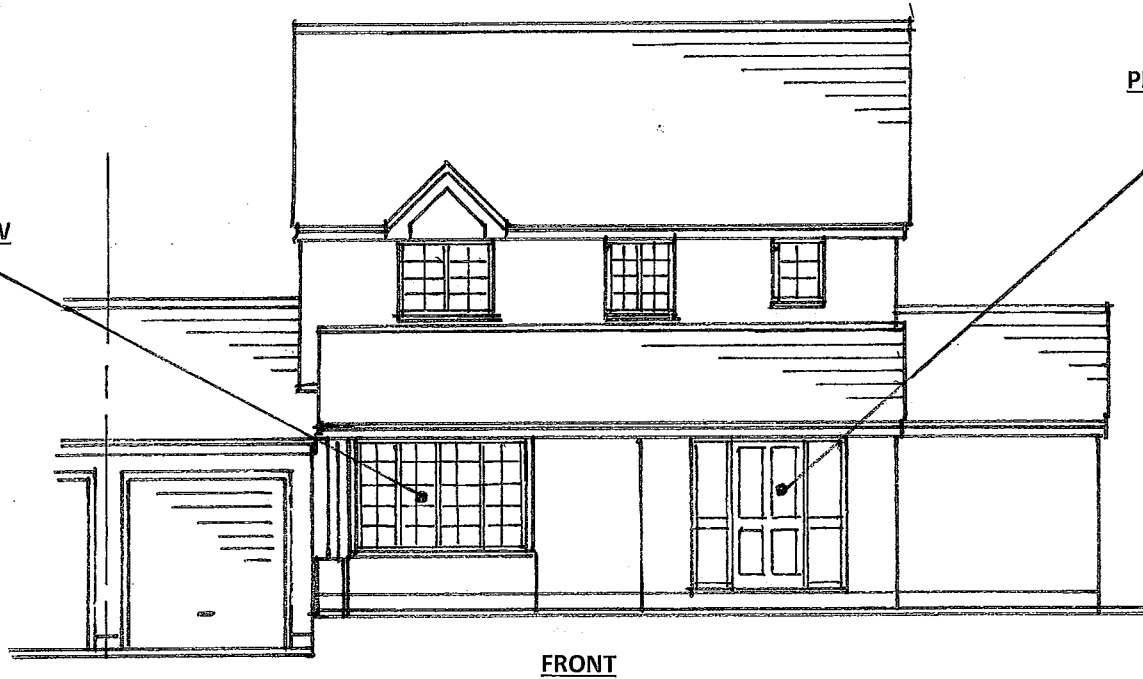
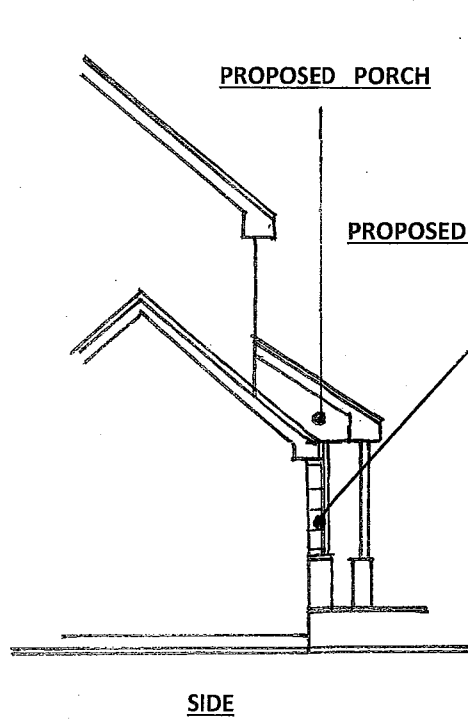

PROPOSED ELEVATIONS 1:100

Alan Wilson
 "Glebeland" Sands Road
 The Sands
 Farnham
 Surrey
 GU10 1LT
 alanjwilson0048@gmail.com
 01252 722965

GENERAL NOTES: Porch Extension
ROOF Tiles to match existing
WALLS Brickwork to match existing
WINDOWS & DOORS Double glazed units in UPVC or PCA frames.
FLOOR LEVELS New floor level to match existing. The site is level

A3 PAPER SIZE

1: 50	0m	1m
1: 100	0m	1m
1: 500	0m	5m
1:1250	0m	10m

GENERAL NOTES: Bay Window Extension
ROOF Tiles to match existing
WALLS Brickwork to match existing
WINDOWS Double glazed units in UPVC frames.
FLOOR LEVELS New floor level to match existing. The site is level

Client	Title	Scales	Revisions	Drg. No.
Mr & Mrs D Collier	Proposed Front Porch & Bay Window	1: 100		2425006/3
23 Worcester Avenue Hatch Warren Basingstoke Hampshire RG22 4PR	Existing & Proposed Elevations			