

PROPOSED SIDE NORTH-EAST ELEVATION

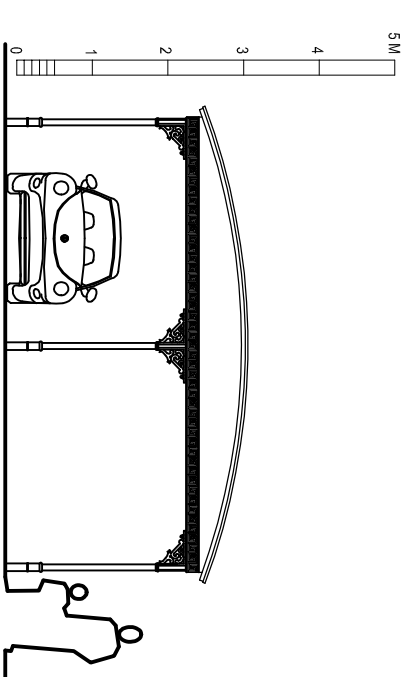

PROPOSED FRONT NORTH-EAST ELEVATION

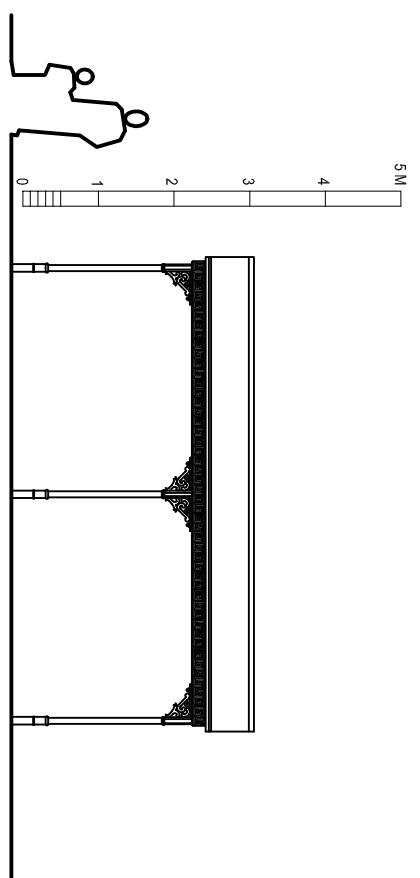

PROPOSED END SOUTH-EAST ELEVATION

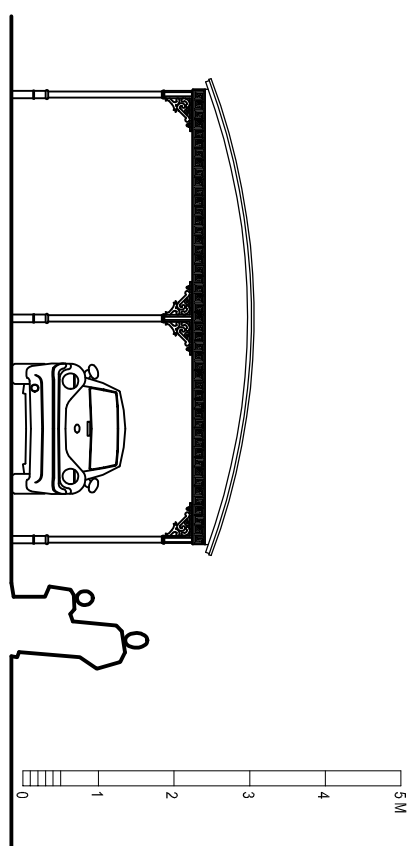

PROPOSED REAR SOUTH-WEST ELEVATION

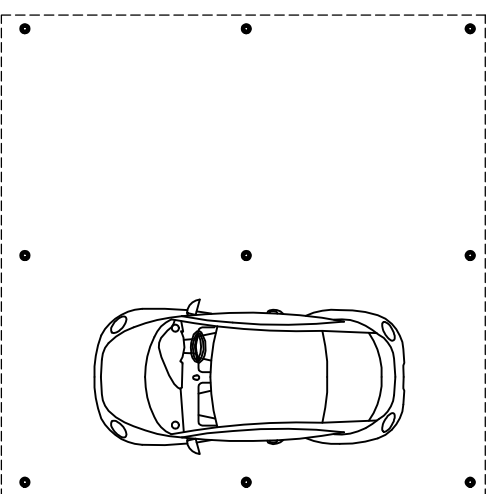

PROPOSED FLOOR PLAN

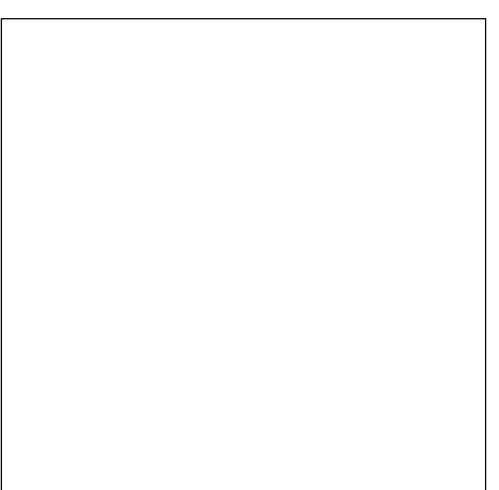

PROPOSED ROOF PLAN

# PLANNING

Planning and Building Regulations Design Consultants  
 Architectural Technologists  
 Local Authorities Planning Agent Group Member  
 Local Authorities Building Control Partner Member  
 Planning Portal Professional Status  
 Landmark and Preweg Member  
 Planning Appeal Consultants

[www.cadmonkies.co.uk](http://www.cadmonkies.co.uk)  
[cadmonkies@btconnect.com](mailto:cadmonkies@btconnect.com)  
 01280 - 70 44 44



Head Office : The Beathouse, 19 Westminster Court,  
 BRACKLEY, Northants, NN15 7ED  
 London Office : Studio 82, Headcorn Road,  
 Thornton Heath, London, CR7 8DQ  
 Cadmonkies, Studio 42 Casha Yard,  
 Richmond, LONDON, TW9 0TF

**CLIENT:** Mr and Mrs H Koerling  
**ADDRESS:** 55 Lee Road  
 BLACKHEATH, SE3 9RT  
**CONTACT:** Mr H Koerling  
**SITE:** 55 Lee Road  
 BLACKHEATH  
 SE3 9RT  
**SCHEME:** Proposed Open Sided Carport with  
 Associated External works.

**DRAWING TITLE:** Proposed Plans

**DATE:** December 2023  
**SCALE:** 1:100

REV.	DATE	BY	APP.
2			
1			

**DRAWING No:** P/23/264/002