



SITING OF A MOBILE HOME

Planning Statement

The Gables
Broad Lane
Finglesham
Deal
CT14 0LY

Date: January 2024
Document Ref: NAPC/JD/1312/JM

TABLE OF CONTENTS

Introduction	3
Application Site and Surroundings	4
Operational Development	5
What is a caravan?	5
Size	5
Mobility	6
Common Mobility Misconceptions	7
Construction	8
Common Construction Misconceptions	9
Operational Development Conclusion	10
Material Change of Use	11
Common Ancillary Misconceptions	12
Material Change of Use Conclusion	13
Planning Precedents	14
Conclusion	15
Appendices	16
Appendix A – Appeal Ref: APP/N1025/C/01/1074589	16
Appendix B – Appeal Ref: APP/L5810/X/15/3140569	17
Appendix C – Appeal Ref: APP/J2210/X/22/3298471	18
Appendix D – Appeal Ref: APP/J1915/X/11/2159970	19
Appendix E – Appeal Ref: APP/B0230/X/22/3295944	20
Appendix F – Appeal Ref: APP/B5480/C/17/3174314	21
Appendix G – Appeal Ref: APP/U1240/C/18/3204771	22
Appendix H – Supporting Statement	23
Appendix I – Appeal Ref: APP/T3725/X/21/3266375	24
Appendix J – Structural Calculations	25
Appendix K – Construction Methodology	26

Introduction

This statement has been prepared by NAPC Ltd in support of an application for a Lawful Development Certificate, seeking approval for a proposed use or development under Section 192 of the Town and Country Planning Act 1990 (as amended). The purpose of this application is to station a mobile home within the residential curtilage of The Gables, Broad Lane, Finglesham, Deal, CT14 0LY.

The definition of development requiring planning permission is outlined in Section 55 of the Town and Country Planning Act 1990 (the Act). It encompasses two primary elements:

1. Operational development being the carrying out of building, engineering, mining, or other operation in, on, over or under land.
2. The making of any material change of use of any buildings or other land.

This Planning Statement provides the rationale behind siting a twin-unit mobile home for ancillary purposes to The Gables. The siting of a mobile home for ancillary purposes does not constitute operational development, or a material change of use, as defined by Section 55 of the Act. Consequently, planning permission is not required.

Moreover, this statement aims to address prevalent misconceptions and respond to inquiries commonly associated with such applications. For the purposes of planning law, the terms 'mobile home' and 'caravan' are treated as synonymous within this statement.

Given that the proposed mobile home does not qualify as operational development, it is important to note that this application does not fall under Class E of Part 1 of Schedule 2 of the GPDO. Class E pertains to operational development, such as the erection of a garden shed or the construction of a garage.

In accordance with the principles set out in the legal precedent of *Gabbittas v SSE and Newham LBC* [1985] J.P.L 630, a Lawful Development Certificate should be evaluated solely based on the facts presented to the Local Planning Authority. The judgment states that the evidence need not be substantiated by 'independent' evidence to be accepted. If the Local Planning Authority lacks evidence to counter or cast doubt on the applicant's account of events, and the applicant's evidence is sufficiently precise and unambiguous, the Lawful Development Certificate should be granted 'on the balance of probability'.

Application Site and Surroundings

The application site is situated on the northern side of the junction between Broad Lane and The Street, situated in east of Finglesham. The dwelling itself is a sizeable, detached bungalow, featuring a light brown brick façade, and pitched tiled roof, and the applicant's lawful occupation designates it as a dwelling house in compliance with C3 usage.

The mobile home will be sited within the garden is outlined in the Block Plan extract below. While minor adjustments may be made, it is imperative to note that the ultimate positioning within the garden does not impact the assessment of this application. The chosen site is strategically selected due to its close physical and functional connection to the main dwelling.



The mobile home is situated entirely within the residential curtilage of the dwelling. The chosen location, characterised by its level terrain, necessitates no groundworks. The dwelling house is located within Flood Zone 3 but is devoid of additional landscape or planning designations. Nevertheless, these factors bear no relevance to the assessment of this application, as the focus is on the placement of the mobile home. Therefore, the application is not assessed in accordance with planning policy or material considerations.

The current vehicular access to the site remains unaltered, and there are no plans for a separate vehicular access to the proposed mobile home unit. This underscores the continuity and minimal impact on existing site logistics.

Operational Development

A caravan is considered as a 'structure.' It is settled in law that the stationing of a caravan on land, even for extended durations, constitutes a use of the land rather than operational development. This fundamental principle is embedded in the legislative framework, endorsed by case law¹, and consistently applied by the Inspectorate.

This perspective arises from the recognition of a caravan as an item of movable personal property, commonly referred to as a 'chattel.' Importantly, there is no public law precluding the placement of a caravan in an individual's garden. As such, the legal standpoint maintains that the act of stationing a caravan on land is a use of the property, and not operational development.

What is a caravan?

The definition of a twin-unit caravan is specified in Section 13 of the Caravan Sites Act 1968, as amended in October 2006 (CSA). According to the CSA, for a structure to be considered a caravan or mobile home, it must satisfy three key tests, as outlined below:

1. Size
2. Mobility
3. Construction

In the following section of this statement, the mobile home will be assessed against the above tests.

Size

Section 13 of The Caravan Sites Act 1968 (amended 2006) outlines the maximum dimensions for a caravan. Our assessment has compared these specified maximum dimensions with the particulars of the proposed mobile home.

	Maximum CSA Requirement	Proposed Size
Length	20.0m	10.05m
Width	6.8m	4.55m
Internal Height (measured from the finished floor level to the highest point of the ceiling)	3.05m	3.0m (internal)

The submitted drawings are accurately scaled and confirm adherence to the specified measurements outlined in Section 13 of The Caravan Sites Act 1968 (amended 2006). It is crucial to emphasise that the height measurement is internal, from the floor to the highest point of the ceiling.

It is clear the proposal does not exceed the prescribed measurements, satisfying the requirements of the size test.

¹ In *Meosor v SOS* (1998), the High Court held that generally a structure that met the definition of 'caravan' for the purposes of the 1960 and 1968 Acts above would not generally be considered a 'building' for the purposes of the 1990 Act above because of the lack of permanence and attachment.

Mobility

Section 13(1)(a) of the Caravan Sites Act 1968 stipulates that a caravan is a structure which 'when assembled, [is] physically capable of being moved by road from one place to another (whether by being towed, or by being transported on a motor vehicle or trailer).'

In this context, "capable" denotes the inherent ability to do something, but not necessarily doing it. The Act does not necessitate a physical demonstration but instead requires a showing, on the balance of probabilities, that the caravan is 'capable of being moved.' Therefore, it is evident that this is a hypothetical test of mobility.

Specific structural calculations, detailed in Appendix J, affirm that the load can be evenly dispersed, ensuring the caravan can be lifted without incurring structural damage. For clarity, this mobile home corresponds to a Ravenscroft model.

The proposed placement of the caravan on a screw pile foundation system, without being fixed down but rather resting on these foundations under its own weight, is illustrated in the diagram below. This design ensures a minimum ground clearance of 150mm, allowing for the use of lifting straps/rigging to be positioned under the structure. Consequently, the caravan can be lifted by crane and placed onto a flatbed lorry.

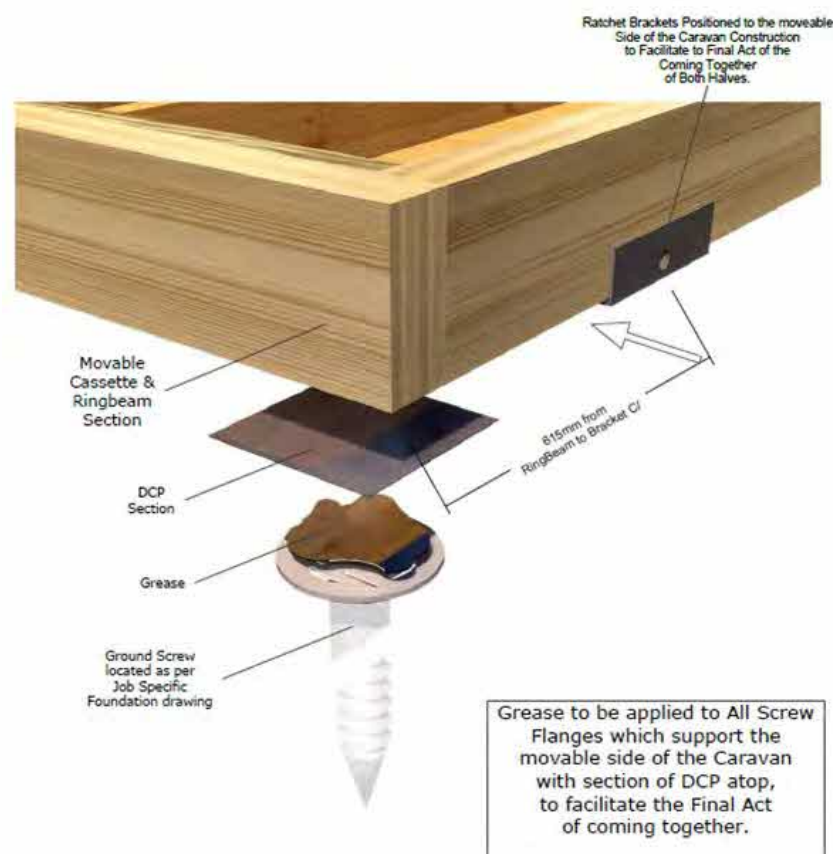

Ground Screw Illustration

The proposed caravan is not affixed to the ground through permanent works, and any connections to services are easily reversible. Legal precedent has established that such connections are deemed de-minimis by the courts.

Considering the caravan can be lifted as a whole unit, which satisfies the mobility test, it is evident that the proposed structure meets the criteria outlined in Section 13(1)(a) of the CSA 1968.

Common Mobility Misconceptions

“You can’t physically move the caravan!”

Appeal Ref: APP/N1025/C/01/1074589 (Appendix A)

‘To fall within this definition the structure must be capable of being moved by road from one place to another in its assembled state. It may be moved by trailer, but it is not excluded from the definition merely because it would be unlawful to move it in such a manner on a highway. The fact that the private drive to [the appeal property] is too narrow to allow the passage of the Park Home in its assembled state along it is not the point. It seems to me that it is the structure that must possess the necessary qualities, not the means of access... It is not necessary for it (a caravan) to be towed, only that it is capable of being moved my road.’

As per the Brightlingsea judgement,² ‘...it is irrelevant to the test where the structure actually is, and whether it may have difficulty in reaching a road.’

Appeal Ref: APP/L5810/X/15/3140569 (Appendix B)

‘The mobility test does not require a mobile home to be mobile in the sense of being moved on any wheels and axles it may have. It is sufficient that the unit can be picked up intact (including its floor and roof) and be put on a lorry by crane or hoist. In the case of twin-unit mobile homes the whole unit must be physically capable of being transportable by road, the illegality of any such transportation on the public highway being irrelevant.’

Appeal Ref: APP/J2210/X/22/3298471 (Appendix C)

‘A factor critical to ascertaining whether the structure would be a caravan, or a building is its mobility. The structure would not be wheeled, nor would it have a drawbar as in a caravan in the conventional sense. However, that does not necessarily mean that the structure would be immobile.’

‘Mobility’ does not require a caravan to be mobile in the sense of being moved on its own wheels and axles. A caravan may be mobile if it can be picked up intact and put on a lorry. The available evidence clearly showed that the structure would be capable of being picked up intact and moved, either by lifting it onto a trailer using a hoist attached to a crane, or by using a removable wheeled skid.’

“You have attached the mobile home to services; therefore, it becomes a permanent structure!”

Appeal Ref: APP/L5810/X/15/3140569 (Appendix B)

Planning Inspector Andrew Dales states in the above appeal that:

‘Similarly, any attachment to services is not the same as physical attachment to the land, as invariably disconnection from such services is a simple matter which can be achieved within minutes if the mobile home needs to be moved. The mobile home would not acquire the degree of permanence and attachment required of building. The mobility test would be met.’

² *Brightlingsea Haven Ltd v. Morris* [2008] EWHC 1928 (QB)

Appeal Ref: APP/J1915/X/11/2159970 (Appendix D)

The assessment by Planning Inspector Martin Joyce within the referenced appeal highlights key considerations related to the mobility of the mobile home:

1. **Test of Capability:** The primary test is whether the unit, when fully assembled, is capable of being towed or transported by a single vehicle. This underscores the focus on the inherent structural qualities that enable potential mobility.
2. **Irrelevance of Intention:** The lack of intention to move the unit around the site is deemed irrelevant to the main issue. This observation recognises that the term "static" in the context of caravans on lawful caravan sites does not negate their classification as caravans. The essential criterion remains the structural capability for theoretical mobility.
3. **Immaterial Practicalities:** Practical considerations, such as a narrow driveway or awkward craning points, are considered immaterial. The critical factor is whether the mobile home possesses the necessary structural qualities for theoretical mobility, irrespective of the site-specific challenges that may impede actual movement.

These points reinforce the legal perspective that the focus of the mobility test is on the inherent structural qualities of the mobile home, emphasizing the theoretical capability for movement rather than immediate practicalities or intentions related to site-specific dynamics.

“The mobile home won’t be moved periodically!”

Appeal Ref: APP/B0230/X/22/3295944 (Appendix E)

‘It is reasonably safe to assume that the unit [mobile home] might remain in situ for some years, having regard to its intended use. Even so, I do not regard this as being a significant factor in relation to the test of permanence. A caravan can often stay in one position for an indeterminate period, without adversely affecting its ability to be moved. For example, a static caravan at a residential or holiday park will often remain in the same position for several years without being moved. Such a caravan would also generally remain connected to services. In no sense could a residential or holiday park caravan be described as a building simply because it had not been moved periodically.’

“The caravan must have wheels and a drawbar to be considered a caravan for planning purposes!”

Appeal Ref: APP/J2210/X/22/3298471 (Appendix C)

The observation that the structure would lack wheels or a drawbar in the conventional sense of a caravan does not automatically render it immobile. The concept of 'mobility' in this context transcends the traditional notion of a caravan being mobile on its own wheels and axles. It is clarified that mobility, for the purposes of legal assessment, extends beyond the specific means of movement commonly associated with caravans.

In essence, the absence of wheels or a drawbar does not preclude the structure from being considered mobile. The determination of mobility is broader, encompassing the potential for the structure to be moved, whether by alternative means such as lifting onto a trailer using a hoist attached to a crane or utilizing a removable wheeled skid. This nuanced interpretation aligns with the legal understanding that mobility is not confined to a specific mode of transportation but is contingent on the structure's inherent capability to be moved in its assembled state.

Construction

The provisions of Section 13(1)(a) of the Caravan Sites Act 1968 pertaining to twin-unit caravans state that the structure should be "composed of not more than two sections separately constructed and designed to be assembled on a site by means of bolts, clamps, or other devices."

In alignment with these specifications, the proposed mobile home will adhere to this definition. It will be assembled on-site, with two distinguishable sections, and the final act of assembly will involve the

bolting of these two parts together. Drawing Ref: 2186.12.23D.10.23.06, included in the application, illustrates the two sections that will be separately constructed on the application site and subsequently joined together on the same site as the 'final act of assembly.' The construction methodology is provided in detail in Appendix K.

Importantly, there is no stipulation in the regulations that the creation of the two parts must occur away from the application site or independently from each other. This key criterion is met by the fact that the two sections will be separately constructed and then joined together through bolting as the conclusive step in the assembly process. In adherence to the specified construction methodology and the outlined process, the construction test, as defined by Section 13(1)(a), is successfully fulfilled.

Common Construction Misconceptions

“You are constructing the two separate parts on site from many pieces, that’s operational development!”

Appeal Ref: APP/N1025/C/01/1074589 (Appendix A)

The key observations include:

1. There is no requirement for the 2 sections to be each identifiable as caravans, or capable of habitation, before they are joined together.
2. A caravan can be delivered to site in many pieces, and there is no requirement in 13(1)(a) that the process of creating the 2 separate sections must take place away from the site on which they are then joined together.
3. It is only necessary the act of joining the 2 sections together should be the final act of assembly.

The leading case, *Byrne v Secretary of State for the Environment and Arun District Council* [1997] EWHC Admin 1990, clarifies that the term "separately constructed" implies an essential part of the construction process. The structure should consist of two sections separately constructed, and the pivotal aspect is that these sections are then designed to be assembled on-site through bolts, clamps, or other devices. This legal precedent underscores the importance of the construction process in bringing a structure within the statutory definition of a caravan.

Appeal Ref: APP/B5480/C/17/3174314 (Appendix F)

The Inspector's conclusions within this appeal align with the legal interpretations derived from cases such as *Byrne* and the *Erewash* decision. The key points highlighted by the Inspector include:

1. **On-Site Construction:** The Inspector rightly notes that there is no requirement for the process of creating the two separate sections to take place away from the land. This interpretation is consistent with the legal understanding derived from precedents like *Byrne* and the *Erewash* decision.
2. **Adjacent Construction and Bolting Together:** The Inspector emphasises that the two halves were constructed on-site adjacent to each other. Importantly, he notes that the final act of assembly involved securely connecting the two sections using a series of bolts along the lines of the walls and floor. This underpins the statutory requirement that the act of joining the sections should be the final act of assembly.

These conclusions reinforce the notion that compliance with Section 13(1)(a) does not necessitate the construction process to occur away from the site. The critical aspect is that the structure is composed of two sections, separately constructed, and designed to be assembled on-site through a final act of joining, in this case, secured by bolts.

Appeal Ref: APP/U1240/C/18/3204771 (Appendix G)

The Inspector stated that:

'I was shown photographs of the whole unit under construction, apparently as one unit, and also as two. It is also clear there was a final act of joining together. It was explained that as the two halves are built up from the various elements of the kit, they are placed side by side in order to ensure they various components would eventually fit together. The two halves were moved apart and back together as required during construction. This seemed to me to be a reasonable explanation of the construction process.'

Operational Development Conclusion

The points above conclude that the proposal meets the definition of a caravan, as outlined in Section 13 of the Caravan Sites Act 1968. Here's a refined summary for clarity:

1. **Size Test:** The proposal not only meets the size test but is significantly smaller than the maximum dimensions allowed by the Caravan Sites Act 1968, demonstrating compliance with this criterion.
2. **Mobility Test:** Clear evidence has been presented to affirm the mobility of the caravan, substantiating that it can be lifted and moved from the site. Legal precedent, as indicated by case law, supports the argument that temporary attachment to services does not constitute permanence, thus satisfying the mobility test.
3. **Construction Test:** The caravan will be assembled on-site into two distinct sections, and these sections will be joined together as the final act of assembly. This methodology has been accepted in both appeal and High Court cases, attesting to its compliance with the construction test.

Considering the above, the proposal meets all three tests outlined in Section 13 of the Caravan Sites Act 1968 and its amendment in October 2006. Consequently, the proposal should be considered a caravan, and, as such, does not constitute operational development.

Material Change of Use

To ensure there is no material change of use of the land, it is imperative that the mobile home remains ancillary/incidental to the C3 residential use. Although there is no statutory planning definition for ancillary/incidental, the following four widely recognised 'incidental' tests, derived from pertinent case law, and documented in the House of Commons (Hansard, 22 November 2005³), serve as benchmarks:

1. The relationship between the respective occupants.
2. The relative size of the house, its garden, and the caravan.
3. The relative scale of accommodation in the caravan and the house.
4. The degree to which the caravan is functionally connected to and subordinate to the use of the dwelling house.

Relationship – The mobile home will be used by the applicant. The provision of the mobile home will allow the applicant to provide essential care and support for his daughter, who will reside in the main dwelling. This is elaborated in the accompanying Personal Statement in Appendix H.

Size/Scale of Accommodation – The proposed caravan entails only a modest increase in footprint. The accommodation within the caravan is designed with minimal scale, offering the necessary facilities for the occupants to lead a comfortable life.

Function – It is crucial to recognise that while a caravan typically possesses all the amenities needed for independent day-to-day living, the mere inclusion of primary living accommodation does not automatically imply a material change of use. The primary intent is to facilitate comfortable living without necessitating a shift in the fundamental use of the property.

To confirm, there will be no separate:

- Address
- Post Box
- Utility meters
- Services (such as internet, phone line and television)
- Parking
- Garden area or curtilage
- Access

The caravan will not be independently registered as a separate unit of occupation for Council Tax purposes. It is crucial to note that the mobile home is not viable in isolation and is dependent on the main dwelling for its functionality and operation, as explicitly outlined in the accompanying supporting personal letter.

The occupant of the mobile home will be the applicant. The provision of the mobile home serves the purpose of enabling the applicant to provide the necessary care and support for his daughter, who will reside in the main dwelling. Consequently, there will be a clear functional interchange of use between the main dwelling and the mobile home by all occupants.

³ <https://publications.parliament.uk/pa/cm200506/cmhansrd/vo051122/debtext/51122-40.htm>

However, it is imperative to emphasise that the assessment of this application must adhere to the stated purpose rather than speculative scenarios. The scope of a LDC is confined to certifying the explicitly applied-for use. If the caravan deviates from its intended use in association with the dwelling, as described, and the functional connection is severed, it will not qualify for the benefits conferred by the LDC.

Common Ancillary Misconceptions

“The mobile home contains all the facilities to be used independently of the main dwelling!”

The judgement in the High Court case *Uttlesford v SoS for the Environment & White* [1991] considered that, even if an annexe within a residential curtilage possesses all the essential living facilities, allowing the occupier to live independently and potentially qualify as a separate dwelling house, this does not automatically signify a material change of use. The Court concurred that the annexe, despite its residential amenities, did not constitute the creation of a separate planning unit that required permission.

The Judge in this case deemed several factors as significant in reaching this conclusion. Noteworthy considerations included the absence of separate utility meters, a postal address, and a dedicated telephone line. Additionally, emphasis was placed on the absence of any delineation of separate curtilage or access arrangements. These considerations supported the view that the annexe, while functionally self-sufficient, did not represent a separate planning unit necessitating formal planning approval.

This is further emphasised in a recent appeal decision ref: APP/J2210/X/22/3298471 (Appendix C) where the Inspector notes in para. 10 that ‘the stationing on land of a caravan for purposes that are part and parcel of and integral to the lawful use as a single residential planning unit would not involve the material change of use... the provision within the curtilage of a dwelling of a separate structure which would provide the facilities for independent day-to-day living but is nevertheless intended to function as part and parcel of the main dwelling would also not involve a material change of use.’

This principle is reaffirmed by a recent appeal decision with the reference APP/T3725/X/21/3266375, as detailed in Appendix I. This decision acknowledges that, regarding LDC applications:

‘Much depends on how the unit [mobile home] would actually be used and the proposal should be assessed on the basis of the stated purpose and not what might possibly occur.’

In the mentioned appeal (APP/T3725/X/21/3266375, Appendix I), the intended occupant of the mobile home was the appellants' Godfather. At the time of the application, the Godfather was residing at the appellants' residence. Given the Godfather's health issues and the anticipation of another baby within the applicant's household, the provision of the mobile home was deemed necessary.

The rationale behind this decision was rooted in the understanding that the limited space within the main dwelling, coupled with the impending addition to the family, would make accommodation challenging. The introduction of the mobile home was a strategic measure to ensure that the Godfather could continue to stay with the appellants. This arrangement aimed to facilitate close support and assistance in managing the health and well-being of their Godfather, thereby addressing the unique circumstances and needs of the occupants.

The Inspector concluded the following:

‘...there would be a family and functional link with the land which would remain in single ownership and control. The proposed use of the mobile home in the manner described would not involve physical or functional separation of the land from the remainder of the property. The character of the use would

be unchanged. Thus, the use described would form part of the residential use within the same planning unit. Only if operational development which is not permitted development is carried out or if a new residential planning unit is created, will there be development.'

Moreover, in a recent appeal referenced as APP/B0230/X/22/3295944 (see Appendix E), the Inspector made a pertinent observation. Acknowledging that the mobile home would serve a function akin to that of a residential annexe, the Inspector reached the conclusion that:

'The intended use would therefore be integral to and part and parcel of the primary use of the planning unit as a single dwellinghouse. The planning unit would remain in single family occupation and would continue to function as a single household. Therefore, as a matter of fact and degree there would be no material change of use.'

"You can't use a mobile home interchangeably with the accommodation in the main dwelling!"

Appeal Ref: APP/L5810/X/15/3140569 (Appendix B)

In this determination, the appointed Inspector stated that a mobile home can be deemed ancillary if it would be used interchangeably with the accommodation in the main dwelling. Specifically, the interchangeability should encompass aspects such as socialising and providing practical support for day-to-day living needs.

Material Change of Use Conclusion

The accompanying supporting letter states that the mobile home will be used ancillary to the main dwelling. Despite the mobile home being equipped with all the necessary facilities for independent use, it is explicitly outlined that the occupants of the mobile home will maintain a reliance on the main dwelling. The main dwelling and the mobile home to be used interchangeably, ensuring the planning unit would remain as one.

The main dwelling and the mobile home will be used in a manner which does not result in a change of use, thus meaning a change of use will not occur.

Planning Precedents

Whilst we note that Lawful Development Certificates are assessed against facts and evidence and are not assessed against a local development plan or material considerations, to ensure this application is determined efficiently and fairly, we would like to direct the LPA towards previous LDC applications that were approved by the LPA. The LPA was satisfied that the proposed mobile home met the statutory definition of a caravan and did not result in a change of use of the land.

Furthermore, it is also worth noting that the proposed mobile home is of a similar size and scale to the approved mobile homes outlined below.

23/00991 – Certificate of Lawfulness (proposed) for the siting of a mobile home for ancillary use (1 Danes Court, Dover, CT16 2QE)

This proposal was for a 9m x 5.66 m mobile home, which featured a bedroom, bathroom, and large living and dining area. The proposed mobile home (10.05m x 4.55) is clearly of an identical size and scale to that of the above application, which demonstrates its acceptability as a mobile home under the Caravan Sites Act 1968, and that it would not result in a material change of use of the land, as it would be ancillary to the host dwelling.

23/00966 – Certificate of Lawfulness (proposed) for the siting of a mobile home for ancillary use (Oatland, Foxborough Hill, Woodnesborough, CT13 0NX)

This proposal was for a 47.25 sqm (10.5m x 4.5m) mobile home, which featured a large bedroom, bathroom, and a large living and dining area. Again, the proposed mobile home is of a near identical size and scale to this mobile home, so it can be reasonably concluded that it is compliant with the Caravan Sites Act 1968 and would clearly be ancillary to the host dwelling.

Conclusion

This statement has been prepared by NAPC Ltd in support of a Lawful Development Certificate for a proposed use of a mobile home for ancillary use to The Gables. The proposal falls within the definitions outlined in the 1960 and 1968 Acts, as amended in 2006, and is considered a mobile home, therefore not resulting in operational development.

The caravan would be situated entirely within the residential curtilage of the existing dwelling, forming an integral part of the planning unit. Furthermore, the applicant explicitly states the mobile home will be used ancillary to the main dwelling. This assertion is reinforced by shared services, the scale of facilities contained within the mobile home, and the commitment to maintaining the site as one planning unit.

In consideration of the submitted evidence and the referenced case law and precedents, it is firmly contended that the correct application of planning law should warrant the issuance of an LDC for the Proposed Use of land.

In conclusion, under the provisions of Section 192 of the 1990 Act, the Lawful Development Certificate for the proposed use or development should be granted.

Appendices

Appendix A – Appeal Ref: APP/N1025/C/01/1074589





Appeal Decision

Inquiry held on 9 April 2002

by **J G Roberts BSc(Hons) DipTP MRTPI**

an Inspector appointed by the Secretary of State for Transport,
Local Government and the Regions

The Planning Inspectorate
4/09 Kite Wing
Temple Quay House
2 The Square
Temple Quay
Bristol BS1 6PN
☎ 0117 372 6372
e-mail: enquiries@planning-
inspectorate.gsi.gov.uk

Date 23 JUN 2002

Appeal Ref: APP/N1025/C/01/1074589

159 Victoria Avenue, Borrowash, Derbyshire.

- The appeal is made under section 174 of the Town and Country Planning Act 1990 as amended by the Planning and Compensation Act 1991.
- The appeal is made by Mr R Brentnall against an enforcement notice issued by Erewash Borough Council.
- The Council's reference is ENF/01/254 P2337.
- The notice was issued on 22 August 2001.
- The breach of planning control as alleged in the notice is without planning permission the erection of a single storey building in the approximate position marked with a cross on the plan attached to the notice.
- The requirements of the notice are:
 - (i) remove the building;
 - (ii) remove from the land all building materials and rubble arising from compliance with requirement (i) above.
- The periods for compliance with these requirements are: (i) Requirement (i) – 12 weeks; Requirement (ii) – 16 weeks.
- The appeal is proceeding on the grounds set out in section 174(2)(b), (c), (d) (f) and (g) of the 1990 Act as amended. An appeal was made on ground (d) but withdrawn on 22 November 2001; after an exchange of correspondence which followed the inquiry the appeal on ground (d) was reinstated. As the appropriate fees were paid within the prescribed period the planning application for planning permission deemed to have been made under section 177(5) of the 1990 Act as amended falls to be considered also. Ground (g) was added during the inquiry.

Summary of Decision: The appeal is allowed and the notice is quashed.

Procedural matters

1. I visited the site on the day of the inquiry. At the inquiry an application for an award of costs was made on behalf of Mr R Brentnall against Erewash Borough Council. This is the subject of a separate decision.

The appeal on ground (b)

2. The notice alleges the erection of a building. The appellant contends that the Park Home is not a building and has not involved operational development of land, but falls within the definition of a caravan. This is found in section 29(1) of the Caravan Sites and Control of Development Act 1960. A caravan means any structure designed or adapted for human habitation which is capable of being moved from one place to another (whether by being towed, or by being transported on a motor vehicle or trailer) and any motor vehicle so designed or adapted, but does not include railway rolling stock in certain circumstances or tents.
-

3. Its application to twin-unit caravans is elaborated in section 13 of the Caravan Sites Act 1968. Such a structure, designed or adapted for human habitation and which is (a) composed of not more than 2 sections separately constructed and designed to be assembled on a site by means of bolts, clamps or other devices; and (b) when assembled, physically capable of being moved by road from one place to another (whether by being towed, or by being transported on a motor vehicle or trailer), shall not be treated as not being a caravan for the purposes of part 1 of the 1960 Act by reason only that it cannot lawfully be so moved on a highway when assembled.
4. However, such a unit which when assembled exceeds 18.288m in length, 6.096m in width or 3.048m in overall height of the living accommodation (measured internally from the floor at the lowest level to the ceiling at the highest level) are specifically excluded from the expression 'caravan' by section 13(2) of the 1968 Act. Thus there are 3 tests to be applied to the Park Home before me: a construction test, a mobility test and a size test. All 3 are contested.

The construction test

5. The local planning authority draws my attention to the analysis of the meaning of the words 'composed of not more than two sections separately constructed and designed to be assembled on a site by means of bolts, clamps or other devices' which was given in *Byrne v SSE and Arun DC, QBD 1997*. There is no requirement for the 2 sections to be each identifiable as caravans, or capable of habitation, before they are joined together. However, it was found that it was an 'essential part of the construction process in order to bring a structure which would not otherwise be a caravan, within the definition of that which is deemed to be a caravan, that there should be two sections separately constructed which are then designed to be assembled on a site..... If the process of construction was not by the creation of two separately constructed sections then joined together, the terms of the paragraph [section 13(1)(a) of the Caravan Sites Act 1968] are not satisfied'. They were not in that case because the log cabin concerned, composed of individual timbers clamped together as in that before me, had not at any time been composed of 2 separately constructed sections which were then joined together on the site.
6. That was not so in the case before me. Though the Park Home was delivered by lorry in many pieces I see no requirement in section 13(1)(a) that the process of creating the 2 separate sections must take place away from the site on which they are then joined together. It is necessary only that the act of joining the 2 sections together should be the final act of assembly. The appellant's evidence and photographs taken during the process of assembly demonstrate that the 2 sections, split at the base and ridge and each with a separate ridge beam, were constructed separately. The appellant was clear on this point. His evidence as to the facts of the matter was not disputed. In my opinion the process of construction fulfilled the test of section 13(1)(a).

The mobility test

7. Section 13(1)(b) of the Caravan Sites Act 1968 must be satisfied also. To fall within the definition the structure must be capable of being moved by road from one place to another in its assembled state. It may be moved by trailer, but is not excluded from the definition merely because it would be unlawful to move it in such a manner on a highway. The fact that the private drive to No 159 Victoria Avenue is too narrow to allow the passage of the Park Home in its assembled state along it is not the point. It seems to me that it is the structure that must possess the necessary qualities, not the means of access. It is not necessary for it to be capable of being towed, only that it is capable of being moved by road.

8. The appellant claims that it would be possible to lift the assembled structure, having first removed the terrace of timber decking and the porch which have been added to its western side, onto a lorry trailer which could then transport it from one place to another. The Council, however, argues that it has not been demonstrated that this could be done without serious significant damage to the structure – would the bolts hold? would it fall apart? – so that it cannot be regarded as transportable in a single piece.
9. I disagree. The manufacturer (Rural Accommodations) refers mainly to its movement in 2 sections, clearly the easier option here, but indicates that the reference to extra supports when shipping relate to extra safety and are not requirements. It would give a guarantee that ‘the unit’ is more than substantial enough to transport by road. Hewden Crane Hire indicates the method by which they would lift it, slew it round and lower it onto the ground or onto transport. The Park Home does not have a tiled roof or similar which would be liable to fall apart during the process. The fact that the cost estimate was based on an allowance of 8 hours does not exclude the Park Home from the definition of a twin-unit caravan.
10. The terrace and porch canopy are bolted to the unit and could be removed quickly and easily. The decking appears to have been attached to the remains of a caravan chassis and does not form an integral part of the structure. In my opinion neither affect the transportability of the assembled Park Home. In my opinion it meets the mobility criterion of the 1968 Act.

The size test

11. There is no dispute that the length and width of the assembled Park Home falls within the limits defined in section 13(2) of that Act, but Mr Thorp’s measurements of internal height give a maximum of 3.060m, 12mm in excess of the maximum internal height measured from floor to ceiling of 10 feet (3.048m) specified in that section. The local planning authority’s view is that either it falls within the size limits or it does not; there is no scope for the appellant’s *de minimis* argument here.
12. However, Rural Accommodations states that the Park Home has been designed and built to a specification of a caravan to be used for permanent residence as defined by the Caravan Sites and Control of Development Act 1960 and the Caravan Sites Act 1968 (BS 3632 : 1995). By implication it had been designed so that its maximum internal height would be no greater than 3.048m. The reason for the difference is not known, but it seems to me that 12mm discrepancy may be within the range of variation that might be expected from natural movement of timber. Further, the same structure could probably be brought within the strict definition of a twin-unit caravan very easily by the addition, for example, of strips of material 12mm thick added to the ceiling by the central ridge, or by plywood laid upon the floor. Its external dimensions would remain unchanged.
13. In these circumstances I agree with the appellant that the excess height is *de minimis*. To exclude the Park Home from the definition of a twin-unit caravan for this reason alone, or because the alterations necessary to bring it within the strict terms of the definition would now offend the construction test, would be verging on the unreasonable.

Conclusion

14. Therefore I regard the Park Home before me is a twin-unit caravan within the definition of the 1968 Caravan Sites Act and a caravan for the purposes of section 29(1) of the Caravan Sites and Control of Development Act 1960. It is clearly designed for and capable of use for

human habitation. The addition of the decking and porch canopy has not affected the integrity of the Park Home as such a twin unit.

15. It may look like a building at first sight. It may be a structure in the sense of something that has been constructed, but so are all caravans. The unit is not attached to the ground except by easily disconnected services. It rests on blocks, paving slabs and hardcore retained by railway sleepers, which have not resulted in a permanent change to the land on which it stands. Save for the 12mm in excessive internal height, which could be remedied easily, it falls within the definition of a twin-unit caravan, which sets it apart from other types of structure and is normally held to be a use of land. It has not become a building through permanence or its degree of physical attachment to the ground.
16. Therefore I conclude that the notice should have alleged the change of use of the land to use for stationing a residential caravan. The appeal on ground (b) succeeds. Whether its actual use is for the purpose of human habitation rests upon the relationship between occupation of the house and that of the caravan. This bears upon the appeal on ground (c). Both parties are fully aware that the notice is directed to the presence of the Park Home on the land. The difference is in their views on whether it should be treated as a caravan or as a building and in what consequences should flow from that determination, but the evidence of both parties covers both eventualities. As I am satisfied that the notice can be corrected without injustice to either I now turn to the appeal on ground (c).

The appeal on ground (c)

17. First, it is agreed by the parties that the whole of No 159 Victoria Avenue remains a single planning unit. I exclude the access track from the road to the gate which is shared with others. The main body of land contains a dwelling house, the Park Home, a swimming pool within a building (disused), a workshop used for the manufacture of picture and mirror frames by the appellant's parents who live in the Park Home, outbuildings, gardens and access, parking and turning areas shared between the house, the Park Home and the workshop.
 18. The appellant retains ownership of the whole and there is no legal separation of the site into 2 parts. Both the house and the Park Home share an identical address, there is a common post box by the gate, the Park Home connects to the same foul water drainage system as the house, and single charges for the whole of the property are made for Council Tax, water and electricity. Only the telephone lines are separate. The Park Home is open to the remainder of the land on 3 sides. I agree that the whole of No 159 beyond the gate is a single planning unit and has been so at least since it was purchased by the appellant's parents in June 1978.
 19. I turn now to the use of this planning unit. It includes use as a dwelling house, to which the gardens, garaging and pool are ancillary or incidental. This is not disputed. There is also the Park Home and the workshop. The implication of the appellant's argument is that the residential use of the Park Home is the same use as that of the dwelling house. There is said to be a degree of dependency, a separate planning unit has not been created, and 2 dwellings cannot occupy a single planning unit, so that there has been no material change of use.
 20. Whether the Park Home accommodation is used for purposes ordinarily incidental to the primary use of the dwelling house as such is not the point here. That is relevant to the question of whether Class E of Part 1 of Schedule 2 to the Town and Country Planning (General Permitted Development) Order 1995 applies, and that is concerned with the erection of buildings. In any event it is now widely accepted that use as living accommodation in connection with the dwelling house would be part and parcel of the main
-

use of that house and not therefore incidental to such (see the Secretary of State's decision reported in [1987] JPL 144 quoted in *Uttlesford DC v SSE and White*, QBD 1991 and also *Michael Rambridge v SSE and East Hertfordshire DC*, QBD 1996. What is relevant is the use of the planning unit as a whole, which raises the question of the relationship between occupation of the house and that of the Park Home.

21. On this I have the unchallenged statement of the appellant and his supporting documents. There is certainly a close blood tie between the appellant, who now occupies the house, and his parents who now occupy the Park Home. They share utility services except the telephone. The parents work in the workshop, and also look after the appellant's son and nephew on occasions.
22. However, in explaining the reasons for the replacement of the former mobile home by the Park Home in May 2001 the appellant refers to the 'best place for them to reside'. Under cross-examination Mr Thorp referred to a 'lot of connectivity' but indicated that the appellant's parents received no daily assistance. The Park Home has and has specifically been designed to provide all the facilities necessary for day to day existence. There is no indication of shared meals and housekeeping arrangements any more than one might expect between friends and family living close by in separate dwellings.
23. On balance I consider that the occupation of the Park Home is sufficiently independent to amount to occupation by a separate household. That is not part of the primary use of the dwelling house but distinct, as the use of a caravan for the purposes of human habitation. It is functionally separate, but because it is not physically separate it has not resulted in the creation of a new planning unit. Nonetheless it represents the material change of use of the planning unit to a use which includes use as a residential caravan for one mobile home. Planning permission has not been granted for this change, which is in breach of planning control. The appeal on ground (c) fails.

The appeal on ground (d)

24. A caravan has been present on the site for many years. Owing to illness the appellant's grandparents, who had been living in a mobile home at Breedon-on-the-Hill, moved to a site alongside the poultry sheds, close to where the Park Home now stands, in early 1979 and, according to the appellant, 'assumed residence from then on'. His detailed personal recollections suggest to me that they lived essentially as a separate household independently of the appellant's parents who occupied the house. He would drop in frequently, as a visitor, for various reasons.
25. His grandfather died in 1988 but his grandmother remained there. She had coal delivered separately from the house. The coal merchant describes the caravan as 'the permanent home for Mrs Brentnall Snr.' There is no indication that she lived as part of her son's household. The aerial photograph taken about 1982 shows the substantial mobile home on the land. Mrs Brentnall Snr moved to a nursing home in about March 1998 and died in 2001, but the mobile home remained, available for occupation but vacant.
26. As his parents faced financial difficulties at the time the appellant bought the house from his parents in November 2000 but it seems that in anticipation of this they had already taken occupation of a touring caravan alongside pending replacement of the now deteriorating mobile home. The old mobile home was removed in April 2001 to make way for the new Park Home which was installed in May that year. In my opinion there is no material difference between the use of the Park Home before me and that of the mobile home which

occupied a site not identical to but overlapping the land on which the Park Home now stands.

27. The matter is complicated by the presence of the workshop, used by both the appellant's parents for the manufacture of picture and mirror frames. In September 1999 planning permission had been refused for the retention of a workshop and enforcement action to secure its removal was authorised, but planning permission was subsequently granted for the continuation of the use in a former egg production building. This is not regarded by the parties as a separate planning unit. Mr Thorp described it, in answer to questions from me, as having been granted only on the basis that it was "ancillary" to the dwelling (in which the appellant's parents then lived) and as "working from home".
28. On the balance of probability it seems to me that in 1979 a material change of use of the planning unit took place without planning permission, from use as a dwelling house to use as a dwelling house and as a caravan site for the stationing of one mobile home used for human habitation. This use continued until early 1998 and resumed, if not in the summer or autumn of 2000 when the touring caravan was occupied (with greater dependence on the house) and the mobile home remained present but vacant, in May 2001 when the Park Home was installed.
29. The circumstances suggest to me that this break in occupation of a mobile home was not sufficient to extinguish the use which by then had become immune from enforcement action by the passage of time and hence lawful. The use remained but was dormant until its point of resumption.
30. The workshop use, introduced in the late 1990s, is not ancillary to the residential use of either the dwelling house or the mobile home in the sense of serving it, nor is it incidental to it in the sense of ordinarily going together with it. It may be more than *de minimis* also. Even if so, its introduction did not result in a further *material* change to the character of the use of the planning unit as a whole, which is large, with a range of outbuildings only part of which is used for mirror and picture framing, and which at that time comprised both the dwelling house and caravan site uses (see *Beach v SSETR and Runnymede BC, QBD 2001*).
31. Hence the '10-year clock' did not start to run again at the point at which the workshop use began. The material change of use (to that including a mobile home) took place in 1979, more than 10 years before the date of the enforcement notice before me, and no further material change of use has taken place since. Therefore it was too late for enforcement action to be taken against the use of the land for stationing the Park Home before me. The appeal on ground (d) succeeds and the notice will be quashed. The deemed planning application and the appeals on ground (f) and (g) do not fall to be considered. The appellant may now wish to apply to the local planning authority for planning permission or a Certificate of Lawful Use or Development in order to obtain any site licence that may be required under the Caravan Sites and Control of Development Act 1960.

Formal Decision

32. In exercise of the powers transferred to me I direct that the notice be corrected by the deletion of the text of paragraph 3 of the notice and substitution therefor of the words 'without planning permission the material change in use of the land from use as a dwelling house to use as a caravan site for one mobile home for the purpose of human habitation'. Subject thereto I allow the appeal and quash the enforcement notice.
-

Information

33. Particulars of the right of appeal against my decision to the High Court are enclosed for those concerned.



Inspector

Appendix B – Appeal Ref: APP/L5810/X/15/3140569



Appeal Decision

Site visit made on 28 April 2016

by Andrew Dale BA (Hons) MA MRTPI

an Inspector appointed by the Secretary of State for Communities and Local Government

Decision date: 26 May 2016

Appeal Ref: APP/L5810/X/15/3140569
27 Elmfield Avenue, Teddington TW11 8BU

- The appeal is made under section 195 of the Town and Country Planning Act 1990 as amended by the Planning and Compensation Act 1991 against a refusal to grant a certificate of lawful use or development (hereinafter "certificate").
- The appeal is made by Mr Albert Ellis, Mrs Joy Ellis, Mr David Ellis and Ms Tracey Agutter against the decision of the Council of the London Borough of Richmond upon Thames.
- The application ref. 14/4973/PS192, dated 01 December 2014, was refused by notice dated 2 September 2015.
- The application was made under section 192(1) (a) of the Town and Country Planning Act 1990 as amended.
- The development for which a certificate is sought is described at section 2.1 of the Planning Statement accompanying the application as "The use of land within the curtilage of the dwelling for the stationing of a mobile home to be occupied ancillary to the main house."

Decision

1. The appeal is allowed and attached to this decision is a certificate describing the proposed use which is considered to be lawful.

Matters of clarification

2. The names of the appellants set out in the heading above have been taken from section 1.5 of their appeal statement. This section is somewhat clearer than the details set out on the application form and the appeal form.
 3. The appellants acknowledge that the location plan is actually scaled to approximately 1:900 (not 1:1250) and the block plan to about 1:400 (not 1:500). The revised plans submitted with an email dated 2 March 2016 are not particularly helpful in their A4 format. I proceed on the basis of the original plans (taking into account the revised scales) and the measurements stated on the plans as appropriate, noting that the location of the mobile home (unit) is stated on the location and block plans to be nominal in any event.
 4. An application for a certificate enables owners or others to ascertain whether specific uses, operations or other activities are or would be lawful. Lawfulness is equated with immunity from enforcement action.
-

5. A certificate is not a planning permission. Thus, the planning merits of the proposed development are not relevant, and they are not therefore issues for me to consider, in the context of an appeal made under section 195 of the 1990 Act as amended.
6. My decision must rest on the facts of the case and the interpretation of any relevant planning law or judicial authority. The burden of proving relevant facts in this appeal rests on the appellants. The test of the evidence is made on the balance of probability.

Main issue

7. I consider that the main issue is whether the Council's decision to refuse to grant a certificate was well founded.

Reasons

8. The proposal would see the introduction of a "Homelodge" mobile home in the sizeable back garden of the appeal property which is a two-storey detached house located in a predominantly residential area.
9. The intention now is for the first two named appellants to occupy the mobile home, whilst their son and daughter-in-law (the last two named appellants) would occupy the existing house from where they would be able to help with their day-to-day living needs. A reverse arrangement was contemplated at the time of the application. I do not consider that this change has any material effect on the appeal as such.
10. As I see it, the main issue turns on whether the provision of this mobile home within the curtilage of the dwelling house would amount to development requiring planning permission.
11. Section 55 of the 1990 Act as amended sets out the meaning of development. The nub of the argument presented by the appellants is that the mobile home to be sited on the land within the curtilage of the dwelling would comply with the statutory definition of a caravan in every respect, such that no operational development would take place and that as the mobile home would be used for purposes incidental to the enjoyment of the dwelling house as such, there would be no material change of use of the planning unit or land.
12. The statement presented by the appellants sets out in full various legislation concerning the meaning of a caravan. In short, the definition of a caravan is any structure designed or adapted for human habitation which is capable of being moved from one place to another, whether by being towed, or by being transported on a motor vehicle or trailer. The structure can comprise not more than two sections designed to be assembled on site, which is physically capable when assembled of being moved by road from one place to another, provided the structure does not exceed specified dimensions.
13. There is no dispute that the proposed mobile home would fall within the specified dimensions of a "caravan", and nor is there any dispute that it would be designed or adapted for human habitation. The Council queries the tests regarding its construction and mobility.

14. I have closely studied the letter dated 27 April 2015 from the managing director of Homelodge Buildings Limited, the attached photographs of that company's units being lifted on to the back of a lorry, the bay plan showing how the structure would comprise no more than two sections which are designed to be assembled by being joined together on the site and the letter dated 16 February 2016 from a qualified structural engineer at Braeburn Structures Ltd.
15. I am satisfied that the mobile home unit would not be composed of more than two sections separately constructed and designed to be assembled on the site by means of bolts. The construction test would be met.
16. The mobility test does not require a mobile home to be mobile in the sense of being moved on any wheels and axles it may have. It is sufficient that the unit can be picked up intact (including its floor and roof) and be put on a lorry by crane or hoist. In the case of twin-unit mobile homes the whole unit must be physically capable of being transportable by road, the illegality of any such transportation on the public highway being irrelevant. As a matter of fact and degree, I consider that the proposed accommodation once assembled would be capable of being moved intact within the terms of the statutory definition.
17. I note that the proposed unit would rest on concrete "pad stones" placed on the ground. As such, the unit's degree of physical attachment to the ground and the effect on mobility would be minimal or non-existent. Similarly, any attachment to services is not the same as physical attachment to the land, as invariably disconnection from such services is a simple matter which can be achieved within minutes, in the event that the mobile home needs to be moved. The mobile home would not acquire the degree of permanence and attachment required of buildings. The mobility test would be met.
18. I consider that what is being proposed meets the definition of a caravan. As the appellants say, it is settled law that stationing a caravan on land, even for prolonged periods, is a use of land rather than operational development. This principle is embedded in the legislative framework, endorsed by case law and routinely applied by the Planning Inspectorate. Thus, the limitations in the General Permitted Development Order that apply to the erection of buildings in the curtilage of a dwelling house have no relevance to this case.
19. The appeal unit would provide accommodation for use ancillary to the residential enjoyment of the main dwelling. The appeal site would remain a single planning unit and that unit would remain in single family occupation. Both the first two named elderly appellants have health problems and are becoming increasingly dependent upon the two younger appellants. The accommodation in the appeal unit would be used interchangeably with the accommodation in the main dwelling for socialising and practical support with day-to-day living needs. A completely separate self-contained dwelling unit is not being provided. I am satisfied, having read all the written representations, that there would be sufficient connection and interaction between the mobile home and the main house, such that there would be no material change of use of the land or planning unit requiring planning permission.
20. The appellants have referred to case law, previous appeal decisions and a considerable number of previous decisions for certificates that were granted by

other local planning authorities for similar proposals. This material supports the case being made by the appellants and I note that the Council has provided no written representations in response to this appeal to directly challenge any of the items submitted.

Conclusion

21. Drawing together the above, I find that, as a matter of fact and degree and on the balance of probability, the provision of the mobile home as proposed would not amount to development requiring planning permission. I conclude, on the evidence now available, that the Council's refusal to grant a certificate was not well founded and that the appeal should succeed. I will exercise the powers transferred to me under section 195(2) of the 1990 Act as amended.

Andrew Dale

INSPECTOR





Appeal Decision

by Stephen Hawkins MA, MRTPI

an Inspector appointed by the Secretary of State

Decision date: 10TH JANUARY 2023

Appeal Ref: APP/J2210/X/22/3298471
26 Friars Close, Whitstable, Kent CT5 1NU

The appeal is made under section 195 of the Town and Country Planning Act 1990 as amended by the Planning and Compensation Act 1991 against a refusal to grant a certificate of lawful use or development (LDC).

The appeal is made by Sally Turner against the decision of Canterbury City Council.

The application Ref CA/22/00409, dated 25 January 2022, was refused by notice dated 26 April 2022.

The application was made under section 192(1)(a) of the Town and Country Planning Act 1990 as amended.

The use for which a certificate of lawful use or development is sought is use of the land for siting a mobile home for use ancillary to the main dwelling.

Decision

1. The appeal is allowed and attached to this decision is a certificate of lawful use or development describing the proposed use which is considered to be lawful.

Preliminary Matter

2. I consider that the appeal can be determined without the need for a site visit. This is because I have been able to reach a decision based on the information already available.

Main Issue

3. The main issue in this appeal is whether the Council's refusal to grant an LDC in respect of the proposal was well-founded. This turns on whether the appellant has been able to show that, on the balance of probability, the proposal would not involve the carrying out of development as defined in s55(1) of the 1990 Act.

Reasons

4. The appeal site contains an enlarged semi-detached dwelling. It is proposed to set up a detached structure described as a mobile home or caravan within the curtilage of the dwelling. The structure would be around 6 m long and 5.5 m wide, the overall height not exceeding 2.7 m. It would have a timber laminate frame with composite timber cladding and a rubber covered roofing material. The structure would contain a living area and kitchen together with a bedroom and ensuite WC.
5. A caravan is defined in s29 of the Caravan Sites and Control of Development Act 1960 as "any structure designed or adapted for human habitation which is capable of being moved from one place to another (whether by being towed, or

- by being transported on a motor vehicle or trailer)...". The stationing on land of a structure which would satisfy the definition of a caravan in s29 of the 1960 Act would not normally involve building operations. The established tests of size, degree of permanence and physical attachment are relevant when ascertaining whether a structure is a building.
6. The size of the structure falls well within the maximum size allowed for caravans in s13(2) of the Caravan Sites Act 1968. The structure would rest on the site solely by means of its own weight. Services would be provided separately and could be detached with ease. The structure would not be fixed to the supporting foundation. There was no dispute between the main parties regarding the limited extent to which the structure would be physically attached to the site and there is nothing before me to suggest that I should find otherwise.
 7. A factor critical to ascertaining whether the structure would be a caravan or a building is its mobility. The structure would not be wheeled, nor would it have a drawbar as in a caravan in the conventional sense. However, that does not necessarily mean that the structure would be immobile. 'Mobility' does not require a caravan to be mobile in the sense of being moved on its own wheels and axles. A caravan may be mobile if it can be picked up intact and put on a lorry. The available evidence clearly showed that the structure would be capable of being picked up intact and moved, either by lifting it onto a trailer using a hoist attached to a crane, or by using a removable wheeled skid.
 8. It is proposed to assemble the structure on site using pre-manufactured components; it was estimated that such works would take around five days to complete. The definition of a caravan contains no requirement for pre-assembly or for it being brought to site intact. Moreover, the number of components involved in assembling the structure has only a limited bearing on whether it is capable of being moved subsequently. The requirements set out in s13(1)(a) of the 1968 Act to be no more than two sections separately constructed and designed to be assembled on a site by means of bolts, clamps or other device apply in respect of twin-unit caravans. However, the above requirements do not extend to single unit caravans. It is more appropriate to regard the structure as a single unit, as it would be much smaller than a twin-unit caravan. The structure would be about a quarter of the floor area of the largest twin-unit allowed by s13(2) of the 1968 Act. Moreover, it is clear that unlike in the case of a twin-unit, the structure could be brought to the site intact if desired. Consequently, the structure does not need to meet the statutory requirements in respect of the maximum number of sections applicable to a twin-unit caravan.
 9. Drawing the above matters together, as a matter of fact and degree the structure would not have the characteristics of a building and it would meet the definition of a caravan in the 1960 Act. It follows that setting up the structure on the site would not involve the carrying out of building operations.
 10. The stationing on land of a caravan for purposes that are part and parcel of and integral to the lawful use as a single residential planning unit would not involve a material change of use. Generally, provision within the curtilage of a dwelling of a separate structure which would provide the facilities for independent day-to-day living but is nevertheless intended to function as part

and parcel of the main dwelling would also not involve a material change of use¹.

11. I am given to understand that the structure would be used to provide additional living accommodation for the appellant's family. It was not disputed that the intended use of the structure would be as an integral part of the primary use of the planning unit as a single dwellinghouse; there is no sound reason why I should find otherwise. As a result, the proposal would also not involve the making of any material change of use.
12. On the balance of probability, the available evidence therefore shows that the proposal would not involve the carrying out of development, as it would not involve undertaking building operations or the making of any material change in the use of the site.

Conclusion

13. For the reasons given above I conclude, on the evidence now available, that the Council's refusal to grant a certificate of lawful use or development in respect of the siting of a mobile home for use ancillary to the main dwelling was not well-founded and that the appeal should succeed. I will exercise the powers transferred to me under section 195(2) of the 1990 Act as amended.

Stephen Hawkins

INSPECTOR

¹ Uttlesford DC v SSE & White [1992] JPL 171.





Appeal Decision

Site visit made on 23 November 2011

by Martin Joyce DipTP MRTPI

an Inspector appointed by the Secretary of State for Communities and Local Government

Decision date: 7 December 2011

Appeal Ref: APP/J1915/X/11/2159970

**4 Waterworks Cottage, Redricks Lane, Sawbridgeworth, Hertfordshire
CM21 0RL**

- The appeal is made under Section 195 of the Town and Country Planning Act 1990 as amended by the Planning and Compensation Act 1991 against a refusal to grant a Certificate of Lawful Use or Development.
- The appeal is made by Mrs K Green against the decision of the East Hertfordshire District Council.
- The application, Ref: 3/11/0954/CL, dated 27 May 2011, was refused by notice dated 18 July 2011.
- The application was made under Section 192(1)(a) of the Town and Country Planning Act 1990 as amended.
- The use for which a Certificate of Lawful Use or Development is sought is the use of part of the established residential curtilage on which to station a mobile home for purposes incidental to the existing dwelling.

Summary of Decision: The appeal is allowed and a Certificate of Lawful Use or Development is issued, in the terms set out below in the Formal Decision.

Main Issue

1. The main issue in this appeal is whether the proposal would constitute operational development or a material change of use of the land.

Reasoning and Appraisal

2. The appellant wishes to site a "Homelodge" mobile home within the residential curtilage of her house, as ancillary accommodation for her elderly parents. The unit would measure 8.45m in length, 3.85m in width and 2.2m/3.2m in height, to the eaves/ridge. It would be delivered to the site on a lorry and would be capable of removal in the same way. It would not be permanently fixed to the ground, but would be connected to services.
3. The Council accept that the dimensions of the structure could fall within those set out for a twin unit caravan in the statutory definition given in the Caravan Sites Act 1968 as amended¹ (CSA), but they consider that its size, permanence and physical attachment would be such that the siting of the unit would be operational development as defined in Section 55 of the Act, rather than a use of the land. In particular, they contend that the determining factor is whether or not the structure is of a design or size that would make it readily mobile around the site. In this context, its size, degree of permanence and impact on

¹ Sub section 13(2) as amended by The Caravan Sites Act 1968 and Social Landlords (Permissible Additional Purposes) (England) Order 2006 (Definition of Caravan) (Amendment) (England) Order 2006 (SI 2006/2374).

the character of the site lead to the conclusion that operational development would occur. Furthermore, the Council cite two items of case law, and refer to previous appeal decisions, to support their contentions in this respect.

4. In consideration of the above matters, I note at the outset that the Council do not dispute that the mobile home would be used for purposes incidental to the enjoyment of the dwellinghouse as such, notwithstanding that occupiers of the mobile home would have facilities that would enable a degree of independent living. The appellant's claim that it would be akin to a "granny annexe" is not therefore at issue, only the question of whether the proposal would be operational development or, as is normally the case, a use of the land.
5. Neither of the cases that the Council rely on relates to the siting of mobile homes or caravans, rather they concern other structures such as a wheeled coal hopper² and a tall mobile tower³. Similarly, the three appeal decisions referred to by them concern the siting of portacabins on land and whether that is operational development or a use of land. I can, therefore, give little weight to these cases and decisions in my determination of this appeal as they do not concern the siting of caravans or mobile homes and are, thus, materially different development. Additionally, I consider that the Council are misguided in their statement that the determining issue is whether the mobile home would be readily moveable around the site. That is not the correct test; rather the test is whether the unit, once fully assembled, is capable, as a whole, of being towed or transported by a single vehicle⁴. In this case, the appellant's statement that this would be the case has not been contradicted. A lack of intention to move the unit around the site is not relevant to the main issue, and would apply to most "static" caravans on any lawful caravan site.
6. The size of the proposed mobile home falls well within the dimensions set out for twin units in the CSA as amended, notwithstanding that it is not specified as a "twin unit", but it appears that the Council consider that its positioning would create a degree of permanence and impact on the character of the site. Impact on character is also of no relevance in a case where the lawfulness of a use is at issue, but the question of permanence is a matter of fact and degree that relates to physical attachment to the ground.
7. In this case, the mobile home would be placed on padstones and is likely to be attached to services such as water, drainage and electricity, although the precise services are not specified in the application. However, attachment to services is not the same as physical attachment to the land, as they can easily be disconnected in the event that the caravan needs to be moved. Additionally, the placing of the mobile home on padstones, or another sound and firm surface, is not, in itself, a building operation as suggested by the Council, notwithstanding that a degree of skill is required in such placement. I know of no support in legislation or case law for such a proposition and the provision of a hard surface within the residential curtilage would, subject to certain limitations, be permitted development under Class F of Part 1 of Schedule 2 to The Town and Country Planning (General Permitted Development) Order 1995 as amended. The Council are, therefore, incorrect in this instance in their interpretation of the permanence of the mobile home as an indication of operational development rather than a use of the land.

² *Cheshire CC v Woodward* [1962] 2 QB 126

³ *Barvis Ltd v Secretary of State for the Environment* [1971] 22 P&CR 710

⁴ *Carter v Secretary of State* [1995] JPL 311

8. I conclude that the proposed development would not constitute operational development, rather it would involve a use of land. As that use would fall within the same use as the remainder of the planning unit, it would not involve a material change of use that requires planning permission.

Other Matters

9. All other matters raised in the written representations have been taken into account, but they do not outweigh the conclusions reached on the main issue of this appeal.

Conclusions

10. For the reasons given above I conclude, on the evidence now available, that the Council's refusal to grant a Certificate of Lawful use or development in respect of the use of part of the established residential curtilage for the stationing of a mobile home for purposes incidental to the existing dwelling was not well-founded and that the appeal should succeed. I will exercise the powers transferred to me under Section 195(2) of the 1990 Act as amended.

FORMAL DECISION

11. The appeal is allowed and attached to this decision is a Certificate of Lawful Use or Development describing the proposed use which is considered to be lawful.

Martin Joyce

INSPECTOR

Appendix E – Appeal Ref: APP/B0230/X/22/3295944





Appeal Decision

Site visit made on 15 March 2023

by Stephen Hawkins MA, MRTPI

an Inspector appointed by the Secretary of State

Decision date: 4TH APRIL 2023

Appeal Ref: APP/B0230/X/22/3295944

34 Hayton Close, Luton LU3 4HD

- The appeal is made under section 195 of the Town and Country Planning Act 1990 as amended by the Planning and Compensation Act 1991 against a refusal to grant a certificate of lawful use or development (LDC).
 - The appeal is made by Mr and Mrs Tracey and Warren Lee against the decision of Luton Borough Council.
 - The application Ref 21/01601/LAWP, dated 16 November 2021, was refused by notice dated 14 January 2022.
 - The application was made under section 192(1)(a) of the Town and Country Planning Act 1990 as amended.
 - The use for which a certificate of lawful use or development is sought is the proposed siting of a caravan for ancillary residential use.
-

Decision

1. The appeal is allowed and attached to this decision is a certificate of lawful use or development describing the proposed use which is considered to be lawful.

Preliminary Matter

2. As there is no description on the application form, the description in the banner heading of the use for which an LDC is sought has been taken from the appeal form. This is similar to the description on the Council's decision notice. I have used a corresponding description on the attached certificate.

Application for costs

3. An application for costs was made by Mr and Mrs Tracey and Warren Lee against Luton Borough Council. This application is the subject of a separate Decision.

Main Issue

4. The main issue in this appeal is whether the Council's refusal to grant an LDC in respect of the proposal was well-founded. This turns on whether the appellants have been able to show that the proposal would not involve the carrying out of development as defined in s55(1) of the 1990 Act.

Reasons

5. The onus is on the appellants to show that the proposal would be lawful, the relevant test of the evidence being on the balance of probability.

6. The appeal property contains a modern two storey, link-detached dwelling. The dwelling has been enlarged to the rear at some stage. It is proposed to set up a freestanding unit, described as a caravan, in the rear garden. The unit would be around 7.8 m in length, around 4.2 m wide and about 2.7 m in height. The unit would contain a living area, kitchen, and a bedroom with an ensuite WC/shower. I am given to understand that the unit is intended to provide additional living accommodation for an adult member of the appellants' immediate family.
7. The definition of development in s55(1) of the 1990 Act includes the carrying out of building operations in, on, over or under land, as well as the making of any material change in the use of any buildings or other land. The definition of a building in s336(1) of the 1990 Act includes any structure or erection, and any part of a building, as so defined, but does not include plant or machinery comprised in a building. The established tests of size, degree of permanence and physical attachment to the ground are relevant in assessing whether the unit would be a building falling within the above definition.
8. A caravan is defined in s29(1) of the Caravan Sites and Control of Development Act 1960 as "any structure designed or adapted for human habitation which is capable of being moved from one place to another (whether by being towed, or by being transported on a motor vehicle or trailer)...". Relevant case law confirms that a structure which met the definition of a caravan would not generally be a building, with regard to permanence and attachment¹.
9. The unit would be composed of two separately constructed sections, which would be brought to the property then joined together. The unit would be much smaller than the maximum dimensions of a twin-unit caravan provided for at s13(2) of the Caravan Sites Act 1968. The unit would rest on supporting screw piles by means of its own weight. Other than connections to utilities, there would be no works physically attaching the unit to the ground. It is highly likely that the utilities could be disconnected with ease, within a short space of time. To fall within the definition of a caravan, the unit does not need to be mobile in the sense of being moved on its own wheels and axles. The unit would be capable of being picked up and moved intact, including its floor and roof, and put on a lorry by crane or hoist. There is a void beneath the unit so that it could be lifted using belts or straps if required. As a result, there is little in terms of the size or the extent of physical attachment to the ground to indicate that the unit would be other than a caravan.
10. In the context of the established tests referenced above, 'permanence' is generally concerned with works that would affect the mobility of a structure-for example, if it were to be fixed to a foundation, or if a brickwork outer skin and/or a roof were to be constructed. No such works are proposed. It is reasonably safe to assume that the unit might remain in situ for some years, having regard to its intended use. Even so, I do not regard this as being a significant factor in relation to the test of permanence. A caravan can often stay in one position for an indeterminate period, without adversely affecting its ability to be moved. For example, a static caravan at a residential or holiday park will often remain in the same position for several years without being moved. Such a caravan would also generally remain connected to services. In no sense could a residential or holiday park caravan be described as a building

¹ Measor v SSETR & Tunbridge Wells DC [1999] JPL 182.

simply because it had not been moved periodically. Neither is the intended use of the unit of great relevance in terms of whether operational development would occur, instead having more application to whether there would be a material change of use.

11. Consequently, on the basis of the available evidence and as a matter of fact and degree, having regard to the factors of size, degree of permanence and physical attachment to the ground the unit would not be a building as defined in s336(1) of the 1990 Act. The unit would however meet the definition of a caravan in s29(1) of the 1960 Act. It follows that the setting up of the unit at the property would not involve the erection of a building.
12. Turning to whether the proposal would involve a material change of use. Although the unit would be self-contained, that does not necessarily mean that a separate planning unit from the main dwelling would be formed. This is because the provision within the curtilage of a dwelling of a separate structure which would provide the facilities for independent day-to-day living but is nevertheless intended to function as part and parcel of the main dwelling would not normally involve the making of a material change of use.
13. My understanding is that the unit would perform a similar function to a residential annexe, with the occupier sharing their living activity, including taking meals and carrying out routine tasks such as laundry, in company with the family members in the main dwelling. The intended use would therefore be integral to and part and parcel of the primary use of the planning unit as a single dwellinghouse. The planning unit would remain in single family occupation and would continue to function as a single household. Therefore, as a matter of fact and degree there would be no material change of use.
14. Accordingly, the available evidence shows that, on the balance of probability, the proposal would not involve the carrying out of development as defined in s55(1) of the 1990 Act, as the setting up of the unit would not amount to a building operation or the making of a material change of use. It is consequently unnecessary to consider whether the proposal would be granted planning permission by Article 3, Schedule 2, Part 1, Class E of the GPDO².

Conclusion

15. For the reasons given above I conclude, on the evidence now available, that the Council's refusal to grant a certificate of lawful use or development in respect of the proposed siting of a caravan for ancillary residential use was not well-founded and that the appeal should succeed. I will exercise the powers transferred to me under section 195(2) of the 1990 Act as amended.

Stephen Hawkins

INSPECTOR

² Town and Country Planning (General Permitted Development) (England) Order 2015 (as amended).



Appeal Decision

Site visit made on 30 October 2017

by D A Hainsworth LL.B(Hons) FRSA Solicitor

an Inspector appointed by the Secretary of State for Communities and Local Government

Decision date: 27 November 2017

Appeal Ref: APP/B5480/C/17/3174314

Land at 28 Lodge Lane, Romford RM5 2EJ

- The appeal is made by Mrs Vicky Rose under section 174 of the Town and Country Planning Act 1990 against an enforcement notice (ref: ENF/49/17) issued by the Council of the London Borough of Havering on 14 March 2017.
- The breach of planning control alleged in the notice is "the erection of an outbuilding" on the Land.
- The requirements of the notice are as follows: -

"EITHER:

- i) Remove the outbuilding in its entirety; and
- ii) Remove from the Land, all materials and debris resulting from compliance with steps [sic] (i).

OR:

- iii) Cease the use of the outbuilding as a self-contained residential unit; and
- iv) Reduce the height of the outbuilding to no more than 2.5m from natural ground level; and
- v) Remove from the Land, all materials and debris resulting from compliance with steps (iii) and (iv)."

- The period for compliance with these requirements is four months.
 - The appeal is proceeding on the grounds set out in section 174(2)(a), (b) and (f).
-

Decision

1. The appeal is allowed and the enforcement notice is quashed.

Reasons for the decision

The enforcement notice

2. The appellant maintains that the notice is a nullity due to "two fundamental errors". The first contention is that Requirement iii) is uncertain because it is not clear whether use as a granny annexe could continue; the second is that there is a mismatch between Requirement iii) and the allegation that an outbuilding has been erected. The Council's response is that the notice clearly identifies the alleged breach as the erection of an outbuilding, but that Requirement iii) should have been worded so as to require the use of the alleged outbuilding to be restricted to purposes incidental to a dwellinghouse, the intention of Requirements iii) and iv) being to bring the alleged outbuilding into line with what householders can carry out as permitted development.
-

3. The notice contains all the elements that it is required by law to contain and in my opinion it has been drafted so as to tell the appellant fairly what is alleged to have been done in breach of planning control and what must be done to remedy the alleged breach if the notice is upheld. Requirement iii) uses a well-understood planning term, as does the alternative wording put forward by the Council. In my view, the issues raised here by the appellant and the Council fall to be dealt with under the submitted grounds of appeal and by consideration of the exercise of the power to correct or vary the notice if this can be done without causing injustice.

Ground (b)

4. Under ground (b) the appellant maintains that the alleged breach of planning control has not occurred as a matter of fact, because what has taken place is not the erection of an outbuilding, but is the siting of the mobile home for which a lawful development certificate has been granted. The Council contend that an outbuilding has been erected in breach of planning control, and that what has taken place could not be the siting of a mobile home because of the method of construction and because the structure could not be moved from one place to another.
5. The lawful development certificate was granted on 4 August 2016 and it declares to be lawful the siting on the land of a mobile home to be used for purposes ancillary to the appellant's house on the land. (I have treated the reference to 29 Lodge Lane in the First Schedule to the certificate as an error, since the main dwelling concerned is clearly No 28.) The certificate states that it is based on the details shown on five drawings. From what I have seen and read about the alleged outbuilding, it appears to be in the location specified on these drawings and to have the same dimensions, external appearance and internal layout as those specified on the drawings (with the addition of some adjoining decking and steps which are not at issue in the appeal).
6. The term "caravan" is defined by statute and the statutory definition applies to the mobile home authorised by the certificate, rather than the ordinary meaning of the word. In the context of the appeal it means a structure designed or adapted for human habitation which is capable of being moved from one place to another (whether by being towed, or by being transported on a motor vehicle or trailer).
7. A "twin-unit caravan" is not treated as being outside this definition by reason only that it cannot lawfully be moved on a highway when assembled. A twin-unit caravan is defined as one that "is composed of not more than two sections separately constructed and designed to be assembled on a site by means of bolts, clamps or other devices" and "is, when assembled, physically capable of being moved by road from one place to another (whether by being towed, or by being transported on a motor vehicle or trailer". These prerequisites are usually referred to as 'the construction test' and 'the mobility test'. There is also a 'size test', but there is no dispute in this appeal that this test has been complied with.
8. As to the construction test, the mobile home for which the certificate was granted should consist of no more than two sections that have been separately constructed and that have been designed to be assembled on the land, and the

joining together of the two sections by the means described should be the final act of assembly. There is no requirement that the process of creating the two separate sections must take place away from the land.

9. The appellant has explained that the components were manufactured in kit form in a factory. The kit included finished panels and boards and timber floor cassettes that were chemically treated, boarded and insulated. These were all stacked into packs and wrapped with tarpaulins ready for transportation. They were then taken to 28 Lodge Lane on a 25ft flatbed wagon, off-loaded at the front using the vehicle's crane and moved manually into the back garden.
10. The appellant indicates that the components were then assembled into two sections, in accordance with the construction plans and the installation method, details of which she has provided. The plans show a front section and a back section. The installation method shows that the two sections, having been completed alongside each other, were then connected securely by using a series of bolts along the lines of the walls and floor.
11. The Council's case in relation to the method of construction relies on their inspections of the works during the assembly period and the photographs that were taken then. They state that the components were not delivered to the site in two sections lifted or craned off a transporter and that the structure was constructed on site by builders, joiners and other tradespeople. They indicate that the materials delivered to site included raw materials, such as timber and felt for the roof, that materials were stored on site and that a skip was placed in the front garden.
12. The Council's evidence is not in conflict with the appellant's explanation of what took place. However, the Council appear not to have appreciated that assembly can take place on site and they have not shown that the construction test, as explained in paragraph 8 above, was not satisfied. In particular, the Council's evidence does not cast doubt on the appellant's explanation of how the two sections were assembled on the land and then joined together in the final act of assembly.
13. As to the mobility test, the mobile home for which the certificate was granted should once fully assembled be physically capable of being moved as a whole by road, by being towed or transported. A lack of intention to move is not relevant, nor is the absence of a suitable means of access or an adequate road network, but the mobile home should possess the necessary structural qualities to permit its movement in one piece without structural damage.
14. The Council concluded from their investigations that it was reasonable to assume that the structure would have to be dismantled in order for it to be moved off the site, because lifting in an intact form would be unlikely to be feasible given the method of construction. They therefore determined that it was not physically capable of being moved as required by the mobility test.
15. The appellant disagrees and has produced a 'Structural integrity and craning method statement', which is supported by drawings and detailed calculations drawn up by experts. The structure rests on plinths and is not fixed to the ground. The statement supports the view that temporary lifting beams could be installed under the structure to enable it to be lifted safely for transportation.

The Council have not disputed these findings and I have no reason to disagree with them.

16. For the above reasons, I am satisfied on the balance of probabilities that both the construction test and the mobility test have been complied with. I have come to the conclusion, as a matter of fact and degree, that the structure is the mobile home for which the lawful development certificate was granted and not an outbuilding. The alleged breach of planning control has therefore not occurred as a matter of fact and the appeal has succeeded on ground (b).

Grounds (a) and (f)

17. The notice has been quashed as a result of the appeal's success on ground (b). Grounds (a) and (f) no longer fall to be considered.

D.A.Hainsworth

INSPECTOR





Appeal Decisions

Hearing Held on 12 June 2019

Site visit made on 12 June 2019

by Simon Hand MA

an Inspector appointed by the Secretary of State for Communities and Local Government

Decision date: 26 June 2019

Appeal A: APP/U1240/C/18/3204771

Trotters Plot, track from Uddens Drive to Clayford Farm, Clayford, Wimborne, Dorset, BH21 7BJ

- The appeal is made under section 174 of the Town and Country Planning Act 1990 as amended by the Planning and Compensation Act 1991.
 - The appeal is made by Mr Lee against an enforcement notice issued by East Dorset District Council.
 - The enforcement notice, numbered ENF/16/0335, was issued on 10 May 2018.
 - The breach of planning control as alleged in the notice is in the approximate position marked with a black cross, unauthorised construction of a timber constructed building used for residential purposes.
 - The requirements of the notice are a) cease the use of the building hatched green for habitable accommodation as a dwelling-house; b) demolish the building hatched green on the attached plan; c) remove all the resulting materials from the land affected following compliance with b) above.
 - The period for compliance with the requirements is 6 months.
 - The appeal is proceeding on the grounds set out in section 174(2) (b), (c), (f) and (g) of the Town and Country Planning Act 1990 as amended. Since the prescribed fees have not been paid within the specified period, the appeal on ground (a) and the application for planning permission deemed to have been made under section 177(5) of the Act as amended have lapsed.
-

Appeal B: APP/U1240/C/18/3207038

Trotters Plot, track from Uddens Drive to Clayford Farm, Clayford, Wimborne, Dorset, BH21 7BJ

- The appeal is made under section 174 of the Town and Country Planning Act 1990 as amended by the Planning and Compensation Act 1991.
 - The appeal is made by Mrs Lee against an enforcement notice issued by East Dorset District Council.
 - The enforcement notice, numbered ENF/16/0335, was issued on 10 May 2018.
 - The breach of planning control as alleged in the notice is in the approximate position marked with a black cross, unauthorised construction of a timber constructed building used for residential purposes.
 - The requirements of the notice are a) cease the use of the building hatched green for habitable accommodation as a dwelling-house; b) demolish the building hatched green on the attached plan; c) remove all the resulting materials from the land affected following compliance with b) above.
 - The period for compliance with the requirements is 6 months.
 - The appeal is proceeding on the grounds set out in section 174(2) (a), (b), (c), (f) and (g) of the Town and Country Planning Act 1990 as amended.
-

Appeal C: APP/U1240/W/18/3219361

Trotters Plot, track from Uddens Drive to Clayford Farm, Clayford, Wimborne, Dorset, BH21 7BJ

- The appeal is made under section 78 of the Town and Country Planning Act 1990 against a refusal to grant planning permission.
 - The appeal is made by Mrs Jenna Lee against the decision of East Dorset District Council.
 - The application Ref 3/17/1982/FUL, dated 14 July 2017, was refused by notice dated 28 June 2018.
 - The development proposed is change of use of equestrian land to residential, replacement septic tank, extension of existing shed for use as store and associated parking area. Demolition of barn, retrospective.
-

Decisions

Appeals A and B 3204771 & 3207038

1. The appeals are allowed and the enforcement notice is quashed.

Appeal C 3219361

2. The appeal is allowed and planning permission is granted for change of use of equestrian land to residential, replacement septic tank, extension of existing shed for use as store and associated parking area. Demolition of barn, retrospective at Trotters Plot, track from Uddens Drive to Clayford Farm, Clayford, Wimborne, Dorset, BH21 7BJ in accordance with the terms of the application, Reference: 3/17/1982/FUL, dated 14 July 2017, subject to the following condition:
 - 1) The development hereby permitted shall be carried out in accordance with the approved plan: Trotters Plot amended block plan, 1:500@A4, submitted with appeal on 23/12/2018. The change of use hereby granted permission shall be restricted only to the area outlined in red on that plan. The parking and turning area shall be used only for the parking and turning of vehicles and for no other purposes.

Costs Application

3. An application for costs relating to Appeals A and B was made by the appellants and is the subject of a separate decision letter.

Background to the Appeals

4. The site lies in the green belt in an area of woodland and pasture somewhat remote from any roads but in an isolated cluster of dwellings and farm buildings. Set to the south of the access track is a paddock which contains the appeal structure, with a modest garden area, parking and turning for several vehicles, a storage shed, a stables with a concrete apron outside and a half built concrete block barn-like building which apparently has planning permission.
5. The appeal structure stands on the site of a former barn, which has been removed and which once contained a caravan. A lawful development certificate exists for the stationing of a caravan for residential purposes on the site of the former barn. The red line drawn around the area which lawfully can be used for that purpose is effectively the footprint of the now demolished barn, which

is also the same size as the appeal structure. In essence, having achieved a lawful use for residential purposes the appellant has tried to take advantage of the current limitations on the size and design for a caravan, in order to maximise their living space.

6. Appeals A and B turn on whether they have overstepped the mark in doing so, in which case they will have inadvertently created a permanent dwelling and the ground (a) is to grant planning permission for that dwelling. However, the appellants made it clear they are not seeking planning permission for a permanent dwelling, except as a last resort, and if the appeal succeeds on ground (b) they withdraw the ground (a) appeal. Appeal C is to provide the new appeal structure with an access, parking and some garden area as the lawful use of all the land outside the new structure is agricultural.

The Appeal on Ground (b)

7. The definition of a caravan is contained within the Caravans Sites Act 1968 to include twin unit caravans provided that they meet the requirements of section 13(1). "A structure designed or adapted for human habitation which — (a) is composed of not more than two sections separately constructed and designed to be assembled on a site by means of bolts, clamps or other devices; and (b) is, when assembled, physically capable of being moved by road from one place to another (whether by being towed, or by being transported on a motor vehicle or trailer)". The Act also includes maximum dimensions and the maximum width is 6.8m. The Council argue that the appeal structure is not a caravan as a matter of fact as it is too wide, is composed of at least three sections which were not constructed separately and then designed to be fastened together and it cannot be moved on the road. The parties therefore agreed the issue turns on the construction test, the mobility test and the dimension test.

The construction test

8. This test falls into two parts, firstly, are there more than 2 sections, and if not, are the sections "separately constructed and designed to be assembled on a site by means of bolts, clamps or other devices". There is no dispute that the living accommodation of the unit consists of two sections. These were manufactured in Romania and delivered to the site broken down into kit form. The final act of construction, once it had been assembled into two halves was to join the them together with bolts etc. The issue between the parties is that the Council allege the two separate halves were actually constructed as one unit on the site, albeit one that was separable into two. It was then moved apart and re-joined in a cynical attempt to pass the construction test.
9. Various court cases and an appeal decision were referenced. In *Byrne*¹, the court held that "if the process of construction was not by the creation of two separately constructed sections then joined together..." it was not a caravan. It is thus clear that the two sections have to be constructed separately before being joined together. In *Brightlingsea*² a lodge that comprised of two parts brought to the site and then joined together was a caravan. Each half sat on a metal chassis with wheels and a towing device. But that is not the case here and there is no suggestion that a caravan is defined as having a chassis or

¹ *Byrne v SSE & Arun DC* (1997) 74 P&CR 420

² *Brightlingsea Haven Ltd and others v Morris and others* [2008] EWHC 1928

wheels. Finally an appeal decision in Borrowash³ accepted that construction of the two halves did not have to take place off site. In the current appeal the kit was assembled on site, and it is agreed this does not prevent it from being a caravan. None of these authorities greatly help in the issues in this appeal, which have to turn on their own facts.

10. I agree that if the Council's analysis of the construction method was the case then the two sections would not have been 'separately constructed', the apparent 'separate' construction would just have been a smokescreen and the structure would not be a caravan within the terms of the Act. However, I do not think this is a fair description of events. I was shown photographs of the whole unit under construction, apparently as one unit, and also as two. It is also clear there was a final act of joining together. It was explained that as the two halves are built up from the various elements of the kit, they are placed side by side in order to ensure they various components would eventually fit together. The two halves were moved apart and back together as required during construction. This seemed to me to be a reasonable explanation of the construction process.
11. A neighbour provided photographs of the end gable at a late stage in construction. This gable contained the longitudinal split of the two halves. It appeared from the photographs that the cladding on the side was fastened in long strips across the two halves, and then, presumably later cut through with a circular saw to re-create the two separate halves again. This too could be fatal to the requirement that the two halves were separately constructed. However, on closer examination it seems the scaffolding pole in the foreground of the picture sat exactly over the actual gap between the two halves and so hid it from view. The cut ends of the cladding could just be seen at one point, suggesting the gap was there, but hidden from view by the scaffold pole. Given the whole structure was delivered in a kit form, and each separate part was made to fit together to form two halves, it seems unlikely the rather crude method of cutting the wood with a circular saw after being fixed would be used to finish the cladding. Consequently I do not consider these photographs show the construction of one unit rather than two. Other photographs showed the roof felting covering the gap between the two halves, but inevitably the roof would have to be waterproofed in this way, this does not mean the construction test is failed.
12. The whole process is somewhat artificial as no doubt it would be easier to design and construct a building of the same dimensions as a single unit, but the two units are required by the Act and by the planning system. In this case it seems to me the design and construction of the two halves was indeed within the wording of s13(a).
13. A subsidiary issue is that the structure consists of more than 2 sections. The two halves are supported on wooden beams which are regularly spaced running from front to back and the beams in turn are lifted off the ground by adjustable metal feet which sit on a base of crushed stone. The metal feet are bolted to the beams, but the accommodation sits on the beams without any direct fastening. The manufacturer of the structure recommends using low walls made of concrete blocks but the appellants chose here the beam and feet option.

³ APP/N1025/C/01/1074589 (19 April 2002).

14. The Council argue that when the two halves are winched off and onto a lorry, the beams and feet will be left behind. They thus form a third section taking the whole structure beyond the limitation of s13. In my view, to form a 'section' of the structure the elements in consideration should form an integral part of that structure. All caravans, mobile homes and park homes (all of which are designed to fall within the definition of a caravan) have to sit on the ground in some way. If they sit flat on the ground there are issue with damp and with future mobility, so they usually are raised off the ground, which also allows pipes for services to be easily run to them and disconnected if they are moved. A touring caravan sits on its chassis and wheels. A much larger mobile home will usually have a metal chassis and wheels, but the wheels will not support the mobile home which will have metal legs that are lowered down to level the unit on the ground. Park homes can have a similar arrangement, but I was informed they can also sit on props of all kinds. I have seen numerous mobile homes that sit at least partly on concrete walls where they are on sloping sites.
15. I was informed the appeal structure is internally structurally sound and the floor is braced so that the beams are not an integral part of its stability. The beams could be removed and each metal leg have a shorter piece of wood (or similar material) to spread the load where it supported the unit above. I agree that this is just a method for supporting the structure above the ground, it is not a separate section, such that the structure could be said to be composed of more than two sections. In my view therefore the construction test is passed.

The mobility test

16. This test is rather more easily dealt with. The Council did not, in the end, dispute the evidence provided that the two halves of the structure could be winched up by a large crane and then put on the back of a trailer to be taken to another site. Their contention was that the third section (the beams and feet) would be left behind. As I have concluded the beams and feet do not form a third section, whether they are left behind or not does not affect the mobility of the two halves that do form the unit, so the mobility test is passed.

The dimension test

17. There is no dispute the wall to wall width of the structure is 6.29m, which is 51cm within the allowance. However, the Council point out that the roof timbers overhang the walls by 40cm on each side to create eaves. To these are attached fascia boards and guttering, adding an extra 12cm to each side, giving a total width of 7.33m or 53cm too much. I agree with the Council that a structure either fits within the measurements or it does not, there is no room for a de minimis excess other than that of a few millimetres which could be explained as measurement error.
18. The appellants position is essentially that it is obvious the measurement is meant to be wall to wall and excludes projecting eaves or rainwater goods etc. This is how the industry as a whole understands it and to find otherwise would be to take away the definition of caravan from numerous mobile and park homes at a stroke. I was shown two plans of mobile homes currently on the market, which were 6.79m wide, plus overhanging eaves and gutters. I was also referred to the case of Brightlingsea (referred to above) where this issue was fully aired and incidentally where the court held that whether

consternation would be caused to manufacturers of mobile homes was irrelevant to the outcome of the case.

19. In *Brightlingsea* the court had to determine whether a lodge was a caravan for the purposes of the 1968 Act. In that case, as in this appeal, the wall to wall measurements were within the 6.8 limits but not if the eaves were included. The court held in paragraph 80 of the judgement "if one is measuring the width of a structure such as the lodges, it is normal to take the wall measurements and to exclude the roof measurements. Secondly it seems to me to be more likely that Parliament would seek to control the wall measurements for width and length rather than the roof measurements".
20. There was considerable discussion at the Hearing about the model conditions for a caravan site, and the Government's response to the consultation on extending the measurements to 6.8m. It is clear from these that the 6.8m is intended to be wall to wall, and the diagram in the consultation response, which is repeated in the model conditions shows exactly that. I accept that these are merely the view of the Government department, not a definitive guide to the Act, and the model conditions are primarily concerned with caravan spacing, rather than actual sizes, nevertheless it is instructive that the advice is consistent in measuring wall to wall. However, the courts view in *Brightlingsea* seems to me to be decisive and also to agree with the Government's own view. I have been given no reasons to consider this appeal should be treated as different from these authorities and so I consider the dimension test is met.

Conclusion

21. Taking this all together I consider the structure enforced against is a caravan within the meaning of the 1968 Act. The matters alleged have not occurred and so the appeal succeeds on ground (b). I shall allow the appeal and quash the notice.

Appeal C – Creation of a Curtilage

22. The s78 appeal is for a material change of use of a defined area of land around the caravan from agricultural to residential. A plan has been supplied which shows the extent of the land affected. This includes an access from the track, a turning area, a small strip of land to the south of the park home and an area around a shed next to the park home.
23. The Council accept that whether the residential structure is a caravan or a permanent dwelling it is reasonable for it to have some form of garden area, an access and some parking. When the original LDC was granted, the red line was drawn tightly around the footprint of the old tin barn which contained the caravan. This, the Council argue, gave the then much smaller caravan an area of land for residential use. The appellant has now filled this land up with the new larger park home, but as I have found it to be lawful, it follows this too should be allowed an area of land around it for residential use. Had I allowed the appeal on ground (a), the Council suggested a strip of land 7m wide to the south and east of the park home would be acceptable. This would take up most, but not all of the proposed access drive and about half the parking and turning area but would be slightly more generous than the proposed garden strip to the south of the park home. What it would exclude is the shed.

24. In my view the turning area is obviously necessary for convenience and safety, and that proposed is more or less the minimum required. The strip of garden to the south is not controversial, and again is the only outdoor garden space available (the land to the north between the park home and the track contains the stable). The shed has been in existence for some years, and that is not in dispute. However, it has been enlarged by the appellants, adding 2m onto the end, turning it from a 4x3m to a 4x5m shed.
25. The site lies in the green belt where inappropriate development is harmful. The NPPF at paragraph 146 notes that certain forms of development, including a material change of use of land, are not inappropriate providing they preserve openness and do not conflict with the purposes of including land in the green belt in first place. The purposes of including land in the green belt are explained in paragraph 134 and these are high level purposes that are not infringed by this minor encroachment. Although a material change of use should preserve openness, this is not a blanket ban on any structures at all but should be seen in the context of what the material change of use is. In this case it is for residential purposes and includes a modest shed which are required for a use that has already been found to be lawful. The small extension of the shed does not in this context harm openness and neither would the parking of cars associated with, what is in this context, a modest bungalow with a small area for parking and turning. Vehicles would have to be parked somewhere and there would potentially be more impact if there was not an identified area to do so. Any further extension of the area into the countryside would require planning permission and could well have an effect on the green belt, but as it is drawn, it seems to me to be entirely reasonable.
26. Consequently, I do not find the proposed material change of use to be inappropriate development. The residential land acquires no permitted development rights, so there should be no further development on the site. It therefore also accord with policy HE3 of the Christchurch and East Dorset Core Strategy which seeks to protect landscape character. The septic tank and demolition of the barn are not opposed by the Council.
27. I shall allow the appeal and grant planning permission for the material change of use, subject to the condition that the uses are limited to the area shown on the plan provided as part of the appeal.

Simon Hand

Inspector

Appendix H – Supporting Statement



Mr P.J. Hill. cc. Louise Hill



04/01/2024

Dear Sir/Madam,

Re: Proposed 'Mobile Home' at The Gables.

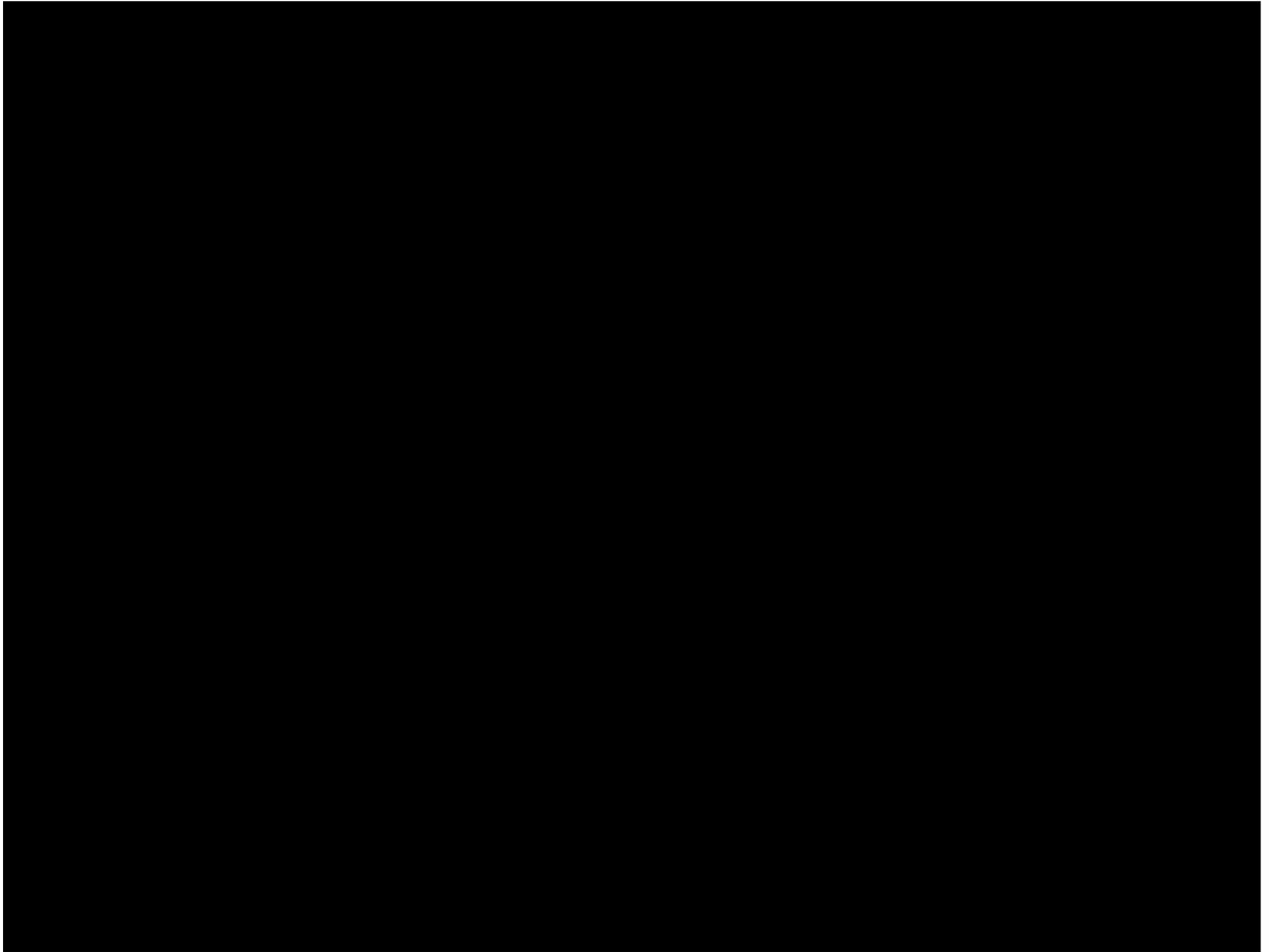

Kind regards,

Peter J. Hill





Appeal Decision

Site visit made on 8 June 2021

by S A Hanson BA (Hons) BTP MRTPI

an Inspector appointed by the Secretary of State

Decision date: 7 July 2021

Appeal Ref: APP/T3725/X/21/3266375

12 Warmington Grove, Warwick CV34 5RZ

The appeal is made under section 195 of the Town and Country Planning Act 1990 as amended by the Planning and Compensation Act 1991 against a refusal to grant a certificate of lawful use or development (LDC).

The appeal is made by Mr and Mrs Darcy Craven against the decision of Warwick District Council.

The application Ref W/20/1189, dated 10 March 2020, was refused by notice dated 11 December 2020.

The application was made under section 192(1)(a) of the Town and Country Planning Act 1990 as amended (the 1990 Act)

The use for which an LDC is sought is the proposed siting of a mobile home/caravan for incidental/ancillary residential use.

Decision

1. The appeal is allowed and attached to this decision is a certificate of lawful use or development describing the proposed use which is considered to be lawful.

Application for costs

2. An application for costs was made by Mr and Mrs Darcy Craven against Warwick District Council. This application is the subject of a separate Decision.

Preliminary matters

3. Section 192(2) of the 1990 Act indicates that if, on an application under that section, the Council is provided with information satisfying it that the use or operations described in the application would be lawful, if instituted or begun at the time of the application, they shall issue a certificate to that effect. In any other case they shall refuse the application.
4. For the avoidance of doubt, the planning merits of the matters applied for do not fall to be considered. The decision will be based strictly on factual evidence, the history and planning status of the site in question and the application of relevant law or judicial authority to the circumstances of the case.
5. Planning Practice Guidance is clear that the applicant (or in this case the appellants) is responsible for providing sufficient information to support an LDC application¹.

¹ Lawful development certificates, paragraph: 006 Reference ID: 17c-006-20140306

Main Issue

6. This is whether the Council's decision to refuse to issue an LDC was well-founded. The decision turns on whether the provision of a mobile home/caravan within the curtilage for incidental/ancillary residential use to the main house would constitute a material change of use of the land, which would require planning permission.

Reasons

7. The appellants seek an LDC to site a mobile home within the garden of their home at 12 Warmington Grove. The use of the mobile home is described as additional living accommodation incidental to the main house rather than separate self-contained residential accommodation.
8. It is undisputed between the parties that, provided the mobile home remains a moveable structure that meets the definition of a "caravan" within the Caravan Sites and Control of Development Act 1960 as amended by the Caravan Sites Act 1968, then it would not constitute a building. Neither is it contested that the proposed siting of the mobile home, as shown on the submitted site plan, would be within the residential curtilage of 12 Warmington Grove.
9. The mobile home would contain a basic kitchenette, a bedroom, bathroom and living area. The mobile home would not be registered as a separate unit of occupation for the purpose of Council Tax. The Council accepted that the proposed unit would share utility services and bills and would not have a separate access or postal address. However, the Council noted that the mobile home would be sited some distance from the main dwelling, "at the far end of an unusually long garden". This, it was said, limits the physical relationship between the house and the proposed mobile home, adding weight to the argument that the mobile home, which includes all of the necessary facilities, would not be ancillary.
10. The mobile home would be positioned some 25m from the main dwellinghouse within a garden that is surrounded on all sides by residential properties. It would be occupied by Mr Edwards who is Mr Craven's Godfather and a surrogate grandfather to the appellants' daughter. Mr Edwards has a long and close family-bond² with the appellants, and he currently resides with the appellants at their home address. The application for the LDC outlined Mr Edward's health issues and provided information to demonstrate how the mobile home would enable him to continue to stay with the appellants, who in turn would be able to provide close support and assistance in managing his health and well-being. I note that part of the reason for providing the mobile home for Mr Edwards is because, when the application was submitted, the appellants were expecting another child and naturally, room within the house would be more limited.
11. The Council note the positive impact on mental and physical wellbeing provided within the doctor's letter. However, they argue that the evidence submitted is not sufficiently precise or unambiguous to indicate that there is an immediate need for Mr Edwards to be fully cared for by the family.
12. However, the issue requiring consideration regarding this appeal is not whether there would be an independent residential use, but rather, whether the

² Since at least 1986 – evidence provided by a written statement from Mr Edwards

proposal would involve a material change of use of land and thus amount to “development” within the meaning of section 55(1) of the 1990 Act. Although the mobile home would be equipped with all the facilities required for independent day-to-day living, it does not follow automatically that once occupied there would be a material change of use simply because primary living accommodation is involved. Much depends on how the unit would actually be used and the proposal should be assessed on the basis of the stated purpose and not what might possibly occur. If there is no material change of use of the land, then there can be no development requiring planning permission.

13. In *Uttlesford DC v SSE & White*³ the judge considered that, even if the accommodation provided facilities for independent day-to-day living it would not necessarily become a separate planning unit from the main dwelling; it would be a matter of fact and degree. The occupant of the annexe in the Uttlesford case was living alone and was in need of care at the time the application was being considered. Whilst the annexe was fully self-contained and gave the occupant some independent space, the level of dependency on the occupiers of the main dwelling for the care received was sufficient to tip the balance in favour of the annexe being ancillary to the main dwelling. The situation is akin to a ‘granny annexe’ in a separate building in the curtilage of the main dwellinghouse, which would normally be regarded as part and parcel of the main dwellinghouse use.
14. In these circumstances, the appellants provide that they are a close-knit family unit that supports and relies on one another in a range of ways including emotional care and support, childcare support, domestic support, general care regarding health and wellbeing and also financial support for one another. In the appellant’s view the family unit demonstrates all the features defined in the term “interdependency relationship”.
15. From the evidence before me, it is clear that there would be a family and functional link with the land which would remain in single ownership and control. The proposed use of the mobile home in the manner described would not involve physical or functional separation of the land from the remainder of the property. The character of the use would be unchanged. Thus, the use described would form part of the residential use within the same planning unit. Only if operational development which is not permitted development is carried out or if a new residential planning unit is created, will there be development. From the application, neither scenario is proposed. Accordingly, the proposal would not require express planning permission.
16. An LDC can only certify the use applied for. If the mobile home is not used in association with the dwelling, as described, and the functional link is severed, then it would not benefit from the LDC.
17. In the circumstances of this case, I find that the siting of a mobile home in the garden of 12 Warmington Grove for the provision of additional living accommodation as described in the application would, as a matter of fact and degree, have been lawful at the time of the application. My findings in this regard are consistent with the approach taken to the application of the law in the other Appeal Decisions⁴ brought to my attention by the appellants.

³ [1992] JPL 171

⁴ APP/K3605/X/12/2181651, APP/L5810/X/15/3140569, APP/C1950/X/19/3247983, APP/Y0435/X/15/3129568

Conclusion

18. For the reasons given above I conclude, on the evidence now available, that the Council's refusal to grant a certificate of lawful use or development in respect of the siting of a caravan for ancillary use was not well-founded and that the appeal should succeed. I will exercise the powers transferred to me under section 195(2) of the 1990 Act as amended.

S A Hanson

INSPECTOR

Appendix J – Structural Calculations



STRUCTURAL CALCULATION



Hibbert Smith Consulting Ltd – Structural & Civil Engineers
T: 07949 171 787 W: www.HibbertSmith.com

Project Ref	P22-0006.128				Project Title	Generic Mobile Home Lifting											
Doc Ref	P22-0006-HSC-Ca-S-128				Doc Title	Generic Mobile Home Lifting Assessment											
Version No	01	Date	Aug 23	Calcs By:	RJS	Date	Aug 23	Check By:	RS	Date	Aug 23	Appr'd By:	RJS	Sheet No	1	Sheet Version	01

Project Details

Client Name: IHus Homes Ltd

Address: General

Grid Reference: n/a

Version Record

Report Ref: P22-0006-HSC-Ca-S-128

Ver	Description	Date	Originator	Checked	Approved
1	Initial Issue	Aug 23	RJS	RS	RJS

STRUCTURAL CALCULATION



Hibbert Smith Consulting Ltd – Structural & Civil Engineers
T: 07949 171 787 W: www.HibbertSmith.com

Project Ref		P22-0006.128				Project Title		Generic Mobile Home Lifting									
Doc Ref		P22-0006-HSC-Ca-S-128				Doc Title		Generic Mobile Home Lifting Assessment									
Version No	01	Date	Aug 23	Calcs By:	RJS	Date	Aug 23	Check By:	RS	Date	Aug 23	Appr'd By:	RJS	Sheet No	2	Sheet Version	01

Introduction

The following document will assess the framework requirements necessary to sit around the Ihus range of garden buildings, such that the home could be lifted from its position as a single unit. In each case, the intention is that steel sections will be passed below the base of the building to support the floor joist ends. These steels will in turn be fixed to two steel sections running parallel to the front and rear elevations. The building will then be lifted by these steels via a steel frame and verticals lowered down from above.

For the purpose of the assessment, only permanent loading will be considered.

STRUCTURAL CALCULATION



Hibbert Smith Consulting Ltd – Structural & Civil Engineers
T: 07949 171 787 W: www.HibbertSmith.com

Project Ref	P22-0006.128				Project Title	Generic Mobile Home Lifting											
Doc Ref	P22-0006-HSC-Ca-S-128				Doc Title	Generic Mobile Home Lifting Assessment											
Version No	01	Date	Aug 23	Calcs By:	RJS	Date	Aug 23	Check By:	RS	Date	Aug 23	Apprd By:	RJS	Sheet No	3	Sheet Version	01

Lifting Frame General Arrangement

It is proposed that the lifting frame will be of a similar style for all buildings, being made up of Needle beams & Needle Ties placed below the building, Edge Beams connecting the needle beams, placed parallel to the front and rear elevations and a braced framework above comprising Columns, Primary Beams, Secondary Beams, Strut Beams, Tie Beams, Cross Braces and Diagonal Braces. The below figure identifies the various sections.

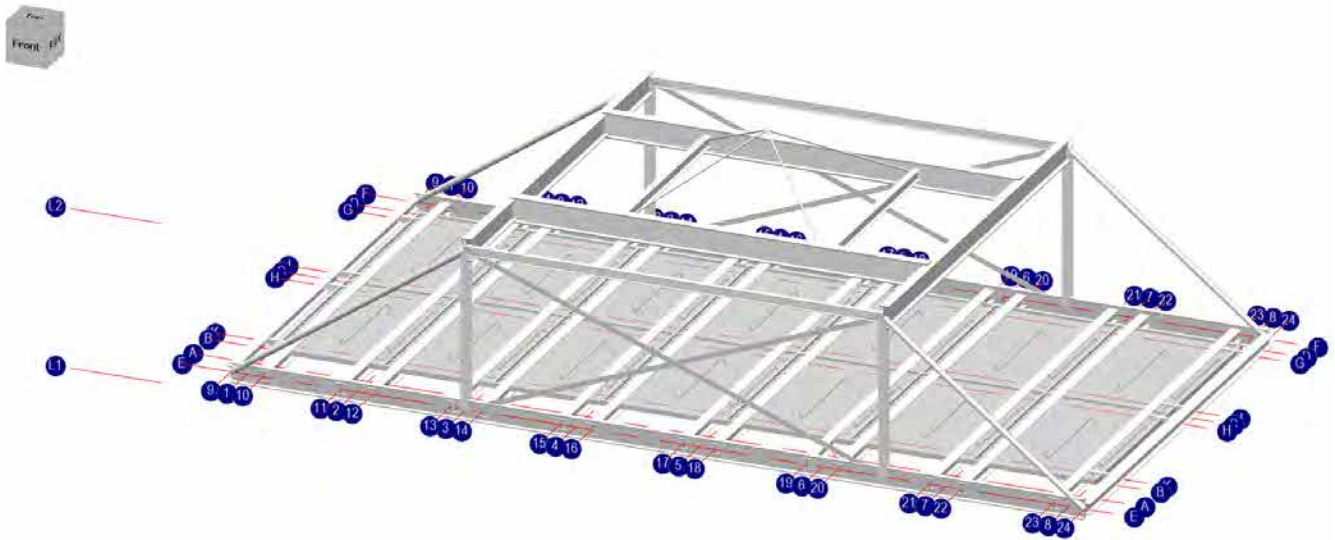
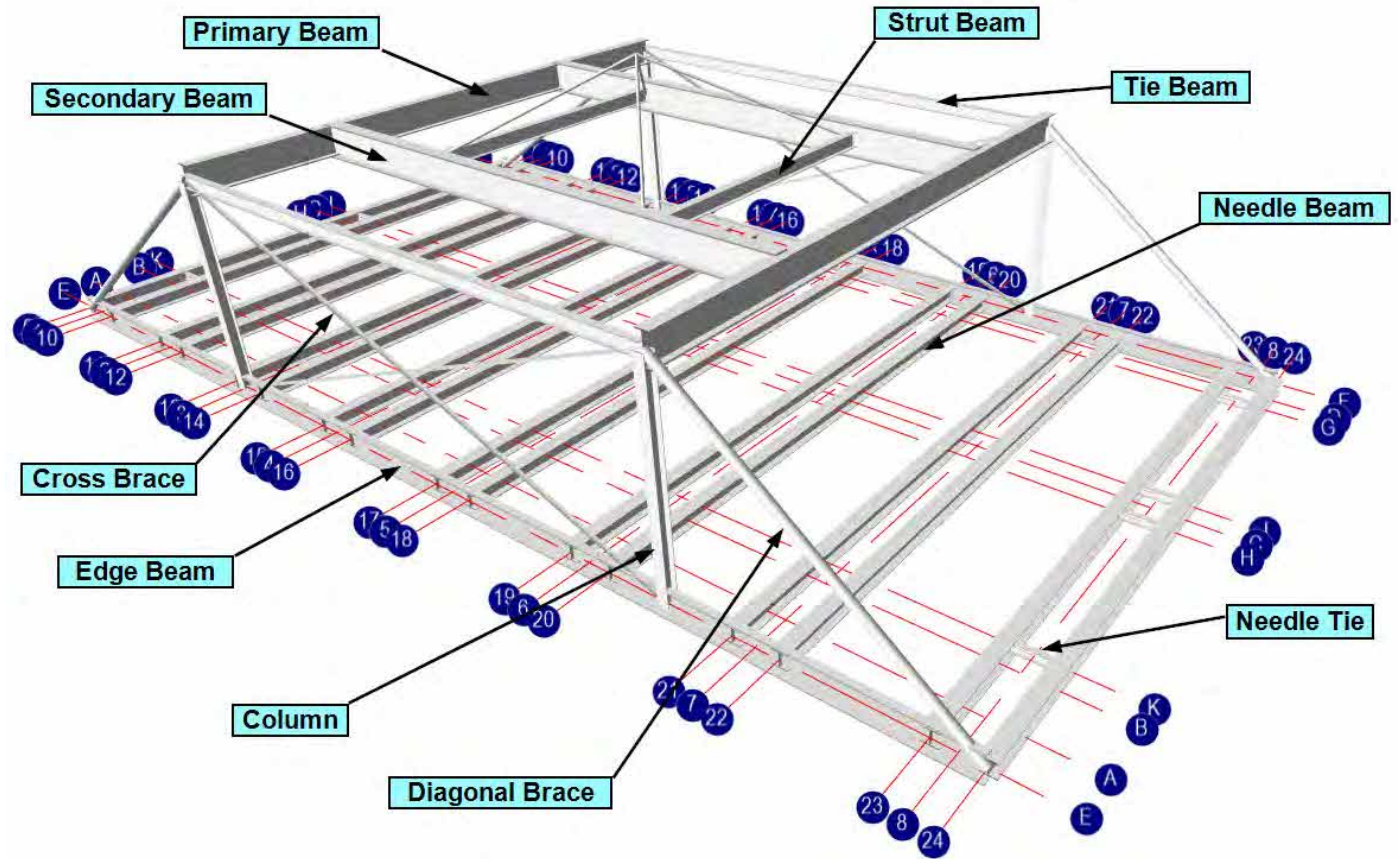

Lifting Frame for Flat Roofed Building

STRUCTURAL CALCULATION



Hibbert Smith Consulting Ltd – Structural & Civil Engineers
T: 07949 171 787 W: www.HibbertSmith.com

Project Ref	P22-0006.128				Project Title	Generic Mobile Home Lifting											
Doc Ref	P22-0006-HSC-Ca-S-128				Doc Title	Generic Mobile Home Lifting Assessment											
Version No	01	Date	Aug 23	Calcs By:	RJS	Date	Aug 23	Check By:	RS	Date	Aug 23	Appr'd By:	RJS	Sheet No	4	Sheet Version	01

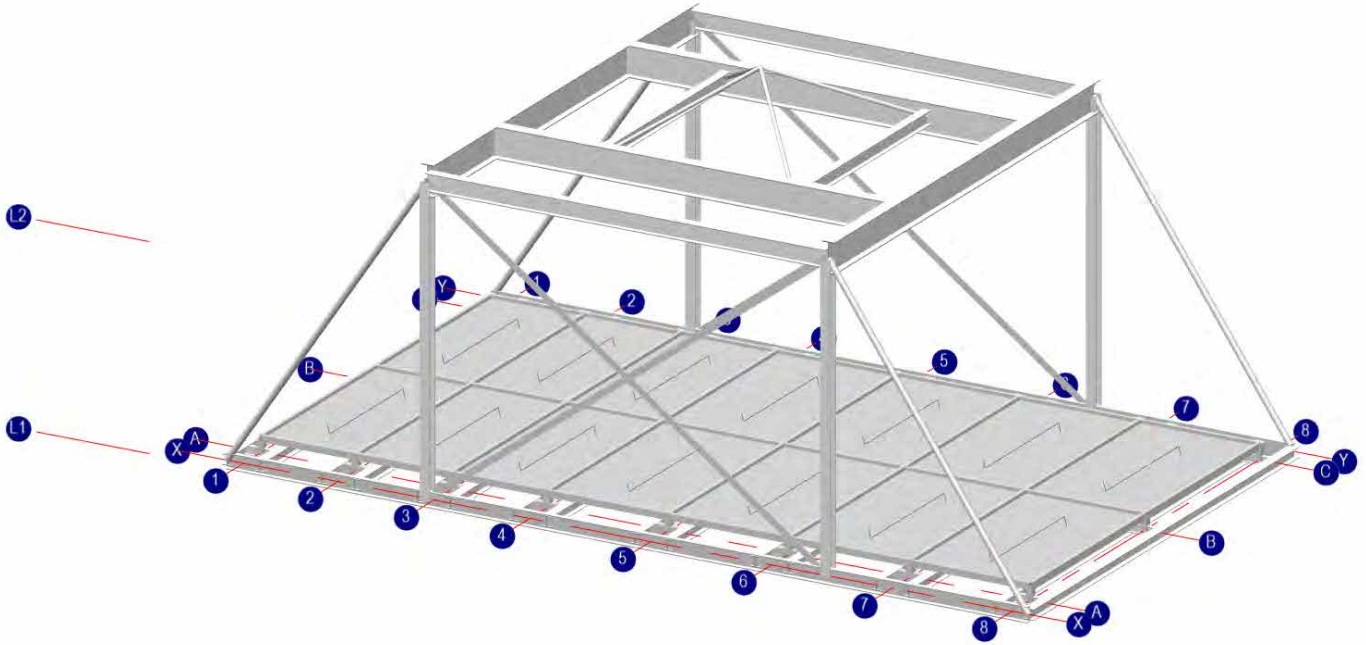

Lifting Frame for Pitched Roof Building

STRUCTURAL CALCULATION



Hibbert Smith Consulting Ltd – Structural & Civil Engineers
T: 07949 171 787 W: www.HibbertSmith.com

Project Ref	P22-0006.128				Project Title	Generic Mobile Home Lifting											
Doc Ref	P22-0006-HSC-Ca-S-128				Doc Title	Generic Mobile Home Lifting Assessment											
Version No	01	Date	Aug 23	Calcs By:	RJS	Date	Aug 23	Check By:	RS	Date	Aug 23	Apprd By:	RJS	Sheet No	5	Sheet Version	01

Building Range



The Bawtry

As one of our most popular one-bedroom annexes, the Bawtry is the perfect choice for elderly care or an independent young adult looking for their first home.



Models featured show standard cladding. Other cladding and finishes are available.
All prices shown are for standard flat roof designs.
<https://ihusanexe.com/annexes/bawtry-granny-annexe/>

The Cantley

The Cantley floorplan is designed to maximise space and fits comfortably into most back gardens.



Models featured show wood cladding. Other cladding and finishes are available.
All prices shown are for standard flat roof designs.
<https://ihusanexe.com/annexes/cantley-granny-annexe/>



STRUCTURAL CALCULATION



Hibbert Smith Consulting Ltd – Structural & Civil Engineers
T: 07949 171 787 W: www.HibbertSmith.com

Project Ref	P22-0006.128				Project Title	Generic Mobile Home Lifting											
Doc Ref	P22-0006-HSC-Ca-S-128				Doc Title	Generic Mobile Home Lifting Assessment											
Version No	01	Date	Aug 23	Calcs By:	RJS	Date	Aug 23	Check By:	RS	Date	Aug 23	Appr'd By:	RJS	Sheet No	6	Sheet Version	01



The Ravenscroft

The Ravenscroft is a spacious one-bedroom annexe, designed for those with a larger garden plot. All three footprints utilise a central shower room to separate the bedroom and the open-plan kitchen/living area to maximise living space.



The Ravenscroft Extra



Models featured show standard cladding. Other cladding and finishes are available.
All prices shown are for standard flat roof designs.
<https://ihusanexe.com/annexes/ravenscroft-granny-annexe/>

The Dunscroft

The L-shaped Dunscroft is an ideal annexe for small corner plots. Each footprint features a double bedroom, shower room and a large open-plan kitchen/living area.



The Dunscroft Extra



Models featured show wood cladding. Other cladding and finishes are available.
All prices shown are for standard flat roof designs.
<https://ihusanexe.com/annexes/dunscroft-granny-annexe/>



STRUCTURAL CALCULATION



Hibbert Smith Consulting Ltd – Structural & Civil Engineers
T: 07949 171 787 W: www.HibbertSmith.com

Project Ref	P22-0006.128				Project Title	Generic Mobile Home Lifting											
Doc Ref	P22-0006-HSC-Ca-S-128				Doc Title	Generic Mobile Home Lifting Assessment											
Version No	01	Date	Aug 23	Calcs By:	RJS	Date	Aug 23	Check By:	RS	Date	Aug 23	Appr'd By:	RJS	Sheet No	7	Sheet Version	01

9.05 m / 29.70 ft



6.05 m / 19.85 ft

The Hickleton

The Hickleton is the largest of our one-bedroom annexes. All three footprints boast a spacious open-plan living area with a galley style kitchen adjacent.



The Hickleton Extra

10.05 m / 32.97 ft



6.55 m / 21.49 ft

12.05 m / 39.53 ft



6.55 m / 21.49 ft



Models featured show standard cladding. Other cladding and finishes are available. All prices shown are for standard flat roof designs. <https://ihusanne.com/annexes/hickleton-granny-annexe/>

The Melton

The Melton is designed with a master bedroom and a smaller second bedroom that can be used as a home study if preferred. The 'Extra Plus' provides a master bedroom larger than in most new build homes today.



The Melton Extra

12.05 m / 39.53 ft



4.55 m / 14.93 ft

13.05 m / 42.81 ft



5.05 m / 16.57 ft

13.55 m / 44.46 ft



5.55 m / 18.20 ft



Models featured show wood cladding. Other cladding and finishes are available. All prices shown are for standard flat roof designs. <https://ihusanne.com/annexes/melton-granny-annexe/>

STRUCTURAL CALCULATION



Hibbert Smith Consulting Ltd – Structural & Civil Engineers
T: 07949 171 787 W: www.HibbertSmith.com

Project Ref	P22-0006.128				Project Title	Generic Mobile Home Lifting											
Doc Ref	P22-0006-HSC-Ca-S-128				Doc Title	Generic Mobile Home Lifting Assessment											
Version No	01	Date	Aug 23	Calcs By:	RJS	Date	Aug 23	Check By:	RS	Date	Aug 23	Apprd By:	RJS	Sheet No	8	Sheet Version	01

9.55 m / 31.33 ft

5.05 m / 16.57 ft

11.05 m / 36.25 ft

5.65 m / 18.54 ft

12.55 m / 41.17 ft

6.05 m / 19.85 ft

The Cadeby

All three footprints offer an alternative layout with a central living space and bedrooms at adjacent sides of the annexe. If you love large open-plan living this annexe is the perfect style for you.



The Cadeby Extra



Models featured show wood cladding. Other cladding and finishes are available.
All prices shown are for standard flat roof designs.
<https://ihusanexe.com/annexes/cadeby-granny-annexe/>

The Loversall

The Loversall provides plenty of living space and two good-sized bedrooms. The 'Extra Plus' is one of the most popular annexes within our Core range.



The Loversall Extra



Models featured show standard cladding. Other cladding and finishes are available.
All prices shown are for standard flat roof designs.
<https://ihusanexe.com/annexes/loversall-granny-annexe/>

8.55 m / 28.05 ft

6.05 m / 19.85 ft

10.05 m / 32.97 ft

6.55 m / 21.49 ft

12.05 m / 39.53 ft

6.55 m / 21.49 ft

STRUCTURAL CALCULATION



Hibbert Smith Consulting Ltd – Structural & Civil Engineers
T: 07949 171 787 W: www.HibbertSmith.com

Project Ref	P22-0006.128				Project Title	Generic Mobile Home Lifting											
Doc Ref	P22-0006-HSC-Ca-S-128				Doc Title	Generic Mobile Home Lifting Assessment											
Version No	01	Date	Aug 23	Calcs By:	RJS	Date	Aug 23	Check By:	RS	Date	Aug 23	Apprd By:	RJS	Sheet No	9	Sheet Version	01

10.05 m / 32.97 ft
4.55 m / 14.93 ft
6.55 m / 21.49 ft
6.00 m / 19.69 ft

11.05 m / 36.25 ft
5.05 m / 16.59 ft
6.55 m / 21.49 ft
5.50 m / 18.04 ft

12.05 m / 39.54 ft
5.48 m / 17.98 ft
6.55 m / 21.49 ft
6.00 m / 19.69 ft

The Hatfield

The Hatfield is a spacious L-shaped annexe with two great-sized bedrooms. All three footprints look stunning and are ideal for large corner plots.



The Hatfield Extra



Models featured show wood cladding. Other cladding and finishes are available.
All prices shown are for standard flat roof designs.
<https://ihusanexe.com/annexes/hatfield-granny-annexe/>

The Wheatley

The Wheatley is our newest, and most popular, two-bedroom annexe. The design provides a large amount of living space, as well as two good-sized bedrooms.



The Wheatley Extra



Models featured show standard cladding. Other cladding and finishes are available.
All prices shown are for standard flat roof designs.
<https://ihusanexe.com/annexes/wheatley-granny-annexe/>

10.05 m / 32.97 ft
6.05 m / 19.85 ft

12.05 m / 39.53 ft
6.55 m / 21.48 ft

13.55 m / 44.46 ft
6.55 m / 21.48 ft

STRUCTURAL CALCULATION



Hibbert Smith Consulting Ltd – Structural & Civil Engineers
T: 07949 171 787 W: www.HibbertSmith.com

Project Ref	P22-0006.128				Project Title	Generic Mobile Home Lifting											
Doc Ref	P22-0006-HSC-Ca-S-128				Doc Title	Generic Mobile Home Lifting Assessment											
Version No	01	Date	Aug 23	Calcs By:	RJS	Date	Aug 23	Check By:	RS	Date	Aug 23	Appr'd By:	RJS	Sheet No	10	Sheet Version	01

Building Dimension Summary

Building Name	Version	Overall Width (m)	Overall Depth (m)
The Bawtry (Ba)	Standard (S)	7.05	5.05
	Extra (E)	8.05	6.05
	Extra Plus (E+)	9.55	6.55
The Cantley (Can)	Standard (S)	8.55	4.55
	Extra (E)	9.55	4.55
	Extra Plus (E+)	10.55	5.05
The Ravenscroft (Ra)	Standard (S)	10.05	4.55
	Extra (E)	12.05	5.05
	Extra Plus (E+)	12.55	5.55
The Dunscroft (Du)	Standard (S)	8.05	5.55
	Extra (E)	9.05	6.05
	Extra Plus (E+)	10.05	6.55
The Hickleton (Hi)	Standard (S)	9.05	6.05
	Extra (E)	10.05	6.55
	Extra Plus (E+)	12.05	6.55
The Melton (Me)	Standard (S)	12.05	4.55
	Extra (E)	13.05	5.05
	Extra Plus (E+)	13.55	5.55
The Cadeby (Cad)	Standard (S)	9.55	5.05
	Extra (E)	11.05	5.65
	Extra Plus (E+)	12.55	6.05
The Loversall (Lo)	Standard (S)	8.55	6.05
	Extra (E)	10.05	6.55
	Extra Plus (E+)	12.05	6.55
The Hatfield (Ha)	Standard (S)	10.05	6.55
	Extra (E)	11.05	6.55
	Extra Plus (E+)	12.05	6.55
The Wheatley (Wh)	Standard (S)	10.05	6.05
	Extra (E)	12.05	6.55
	Extra Plus (E+)	13.55	6.55

STRUCTURAL CALCULATION



Hibbert Smith Consulting Ltd – Structural & Civil Engineers
T: 07949 171 787 W: www.HibbertSmith.com

Project Ref	P22-0006.128				Project Title	Generic Mobile Home Lifting											
Doc Ref	P22-0006-HSC-Ca-S-128				Doc Title	Generic Mobile Home Lifting Assessment											
Version No	01	Date	Aug 23	Calcs By:	RJS	Date	Aug 23	Check By:	RS	Date	Aug 23	Appr'd By:	RJS	Sheet No	11	Sheet Version	01

Summary of Building sizes		Overall Depth (m)				
		4.55	5.05	5.55	6.05	6.55
Overall Width (m)	7.05		BaS			
	8.05			DuS	BaE	
	8.55	CanS			LoS	
	9.05				DuE,HiS	
	9.55	CanE	CadS			BaE+
	10.05	RaS			WhS	DuS+,HiE,LoE,HaS
	10.55		CanE+			
	11.05			CadE		HaE
	12.05	MeS	RaE			HiE+,LoE+,HaE+,WhE
	12.55			RaE+	CadE+	
	13.05		MeE			
	13.55			MeE+		WhE+

Width	No of Cassettes	Cassette Width	Depth Variations		
7.05	4	1.69	5.05	5.55	
8.05	5	1.55	5.55	6.05	
8.55	5	1.65	4.55	6.05	
9.05	5	1.75	6.05		
9.55	5	1.85	4.55	5.05	6.55
10.05	6	1.63	4.55	6.05	6.55
10.55	6	1.71	5.05		
11.05	6	1.79	5.55	6.55	
12.05	7	1.68	4.55	5.05	6.55
12.55	7	1.75	5.55	6.05	
13.05	7	1.82	5.05		
13.55	7	1.89	5.55	6.55	

Cassette Width – 1.9m

STRUCTURAL CALCULATION



Hibbert Smith Consulting Ltd – Structural & Civil Engineers
T: 07949 171 787 W: www.HibbertSmith.com

Project Ref	P22-0006.128				Project Title	Generic Mobile Home Lifting							
Doc Ref	P22-0006-HSC-Ca-S-128				Doc Title	Generic Mobile Home Lifting Assessment							
Version No	01	Date	Aug 23	Calcs By:	RJS	Date	Aug 23	Check By:	RS	Date	Aug 23	Appr'd By:	RJS

Sheet No	12	Sheet Version	01
----------	----	---------------	----

Width	No of Cassettes	Cassette Width	Depth Variations		
7.05	3	2.25	5.05	5.55	
8.05	4	1.94	5.55	6.05	
8.55	4	2.06	4.55	6.05	
9.05	4	2.19	6.05		
9.55	4	2.31	4.55	5.05	6.55
10.05	5	1.95	4.55	6.05	6.55
10.55	5	2.05	5.05		
11.05	5	2.15	5.55	6.55	
12.05	6	1.96	4.55	5.05	6.55
12.55	6	2.04	5.55	6.05	
13.05	6	2.13	5.05		
13.55	6	2.21	5.55	6.55	

Cassette Width – 2.3m

STRUCTURAL CALCULATION



Project Ref	P22-0006.128				Project Title	Generic Mobile Home Lifting											
Doc Ref	P22-0006-HSC-Ca-S-128				Doc Title	Generic Mobile Home Lifting Assessment											
Version No	01	Date	Aug 23	Calcs By:	RJS	Date	Aug 23	Check By:	RS	Date	Aug 23	Appr'd By:	RJS	Sheet No	13	Sheet Version	01

Loading Assessment

Flat Roof

Permanent Loading

Weatherboard (18mm Sheathing Board & MDPE Covering)	0.200
Battens 25x50 @ 300c/c – (Density 6kN/m3) – 0.025 x 6 x (50/300)	0.025
Firrings 60 to 140 x 38 @ 600	0.038
Breather Quilt	0.010
Insulation 200mm (Density 0.55 kN/m3)	0.110
Rafters – 63x245 Eng Joist @ 550 c/c (3.5 kg/m run)	0.065
Plasterboard & Skim – (Density 7kN/m3) – 0.015 x 7	0.105
Services (Allowance)	0.150
Total	0.703 kN/m2

(applied on Slope (5 deg)) equates to 0.703 kN/m2 on Plan – Adopt 0.80kN/m2

Pitched Roof

Permanent Loading

Tiles	0.450
Battens 25x50 @ 300c/c – (Density 6kN/m3) – 0.025 x 6 x (50/300)	0.025
Breather Quilt	0.010
Pitched Total	0.485
(25 Degree Pitch) Plan Total	0.535
Insulation 180mm (Density 0.55 kN/m3)	0.100
Trussed Rafters	0.076
Plasterboard & Skim – (Density 7kN/m3) – 0.015 x 7	0.105
Services (Allowance)	0.100
Total	0.916 kN/m2

Adopt 0.95kN/m2 on Plan

Ground Floor

Permanent Loading

9mm Plywood (Density 7.0 kN/m3) 0.009 x 7	0.063
225x47 Joists : 450c/c (Density 8 kN/m3) 0.225 x 8 x (47/450)	0.188
Insulation 200mm (Density 0.55 kN/m3)	0.110
22mm OSB Deck (Density 6.5 kN/m3) 0.022 x 6.5	0.143
12mm Laminate Floor (Density 7 kN/m3) 0.012 x 7	0.084
Total	0.588kN/m2

Adopt 0.60 kN/m2

STRUCTURAL CALCULATION



Hibbert Smith Consulting Ltd – Structural & Civil Engineers
T: 07949 171 787 W: www.HibbertSmith.com

Project Ref	P22-0006.128				Project Title	Generic Mobile Home Lifting											
Doc Ref	P22-0006-HSC-Ca-S-128				Doc Title	Generic Mobile Home Lifting Assessment											
Version No	01	Date	Aug 23	Calcs By:	RJS	Date	Aug 23	Check By:	RS	Date	Aug 23	Appr'd By:	RJS	Sheet No	14	Sheet Version	01

External Wall

Permanent Load

Marley Cedral Weatherboard – 11.2 x 1.74 x 10/1000	0.195
Battens – 38x25 @ 600c/c (Density 6.0 kN/m ³)	0.015
Breather Membrane	0.011
Sheathing Board – 12mm OSB – (Density 6.5 kN/m ³) – 0.012 x 6.5	0.080
Studs – 38 x 140 @ 450c/c (Density 6.0 kN/m ³) - 0.14 x 6 x (38/450)	0.071
Insulation 100mm (Density 0.55 kN/m ³)	0.055
37mm Insulated Plasterboard (12mm Plasterboard & 25mm PIR) + 0.084 +0.014	0.098
3mm Skim– (Density 7kN/m ³) – 0.003 x 7	0.021
Breather Membrane & Moisture Barrier	0.011
Total	0.557 kN/m²

External wall line load - $0.557 \times 3.0 = 1.671 \text{ kN/m}$ – Adopt 1.75 kN/m

Internal Wall

Permanent Load

Studs – 38 x 100 @ 450c/c (Density 6.0 kN/m ³) - 0.10 x 6 x (38/450)	0.050
2x 15mm Plasterboard & Skim – (Density 7kN/m ³) – 0.015 x 7 x 2	0.210
Total	0.260 kN/m²

Internal Wall Line Load – $0.260 \times 2.4 = 0.624 \text{ kN/m}$ – Adopt 0.65 kN/m

STRUCTURAL CALCULATION



Hibbert Smith Consulting Ltd – Structural & Civil Engineers
T: 07949 171 787 W: www.HibbertSmith.com

Project Ref	P22-0006.128				Project Title	Generic Mobile Home Lifting											
Doc Ref	P22-0006-HSC-Ca-S-128				Doc Title	Generic Mobile Home Lifting Assessment											
Version No	01	Date	Aug 23	Calcs By:	RJS	Date	Aug 23	Check By:	RS	Date	Aug 23	Appr'd By:	RJS	Sheet No	15	Sheet Version	01

Needle Loading Analysis & Beam Design

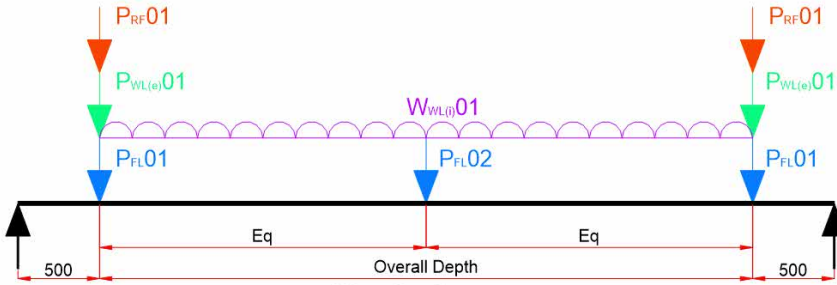

Needle Beam
Loading Arrangement - No Canopy

- $P_{RF01} = W_{RF} \times S_N \times D / 2$ - Point Load due to Roof
- $P_{WL(e)01} = W_{WL(e)} \times S_N$ - Point Load due to External Wall
- $P_{FL01} = W_{FL} \times S_N \times D / 4$ - Point Load due to Ground Floor
- $P_{FL02} = W_{FL} \times S_N \times D / 2$ - Point Load due to Ground Floor
- $W_{WL(i)01} = W_{WL(i)}$ - Distributed load due to Internal Partition Wall

Needle Beam Loading Arrangement – Pitched Roof Buildings and Flat Roof Buildings with No Canopy

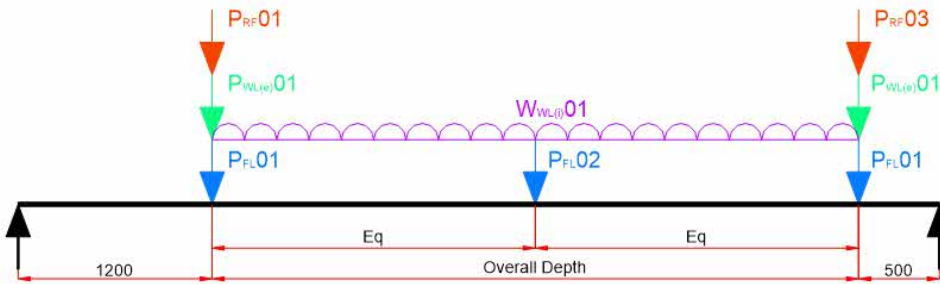

Needle Beam
Loading Arrangement - With Canopy

- $P_{RF01} = W_{RF} \times S_N \times (D / 2 + 0.7)$ - Point Load due to Roof & Canopy
- $P_{RF03} = W_{RF} \times S_N \times D / 2$ - Point Load due to Roof
- $P_{WL(e)01} = W_{WL(e)} \times S_N$ - Point Load due to External Wall
- $P_{FL01} = W_{FL} \times S_N \times D / 4$ - Point Load due to Ground Floor
- $P_{FL02} = W_{FL} \times S_N \times D / 2$ - Point Load due to Ground Floor
- $W_{WL(i)01} = W_{WL(i)}$ - Distributed load due to Internal Partition Wall

Needle Beam Loading Arrangement – Flat Roof Buildings with Canopy

STRUCTURAL CALCULATION



Hibbert Smith Consulting Ltd – Structural & Civil Engineers
T: 07949 171 787 W: www.HibbertSmith.com

Project Ref	P22-0006.128				Project Title	Generic Mobile Home Lifting											
Doc Ref	P22-0006-HSC-Ca-S-128				Doc Title	Generic Mobile Home Lifting Assessment											
Version No	01	Date	Aug 23	Calcs By:	RJS	Date	Aug 23	Check By:	RS	Date	Aug 23	Appr'd By:	RJS	Sheet No	16	Sheet Version	01

Flat Roof - No Canopy	A-01	A-02	A-03	A-04	A-05
Depth (m)	4.60	5.10	5.60	6.10	6.60
Needle Space (m)	1.90	1.90	1.90	1.90	1.90
W(RF-Flat) (kN/m ²)	0.80	0.80	0.80	0.80	0.80
W(FL) (kN/m ²)	0.60	0.60	0.60	0.60	0.60
W(WL-ext) (kN/m)	1.75	1.75	1.75	1.75	1.75
W(WL-int) (kN/m)	0.65	0.65	0.65	0.65	0.65
P _{RF01} (kN)	3.50	3.88	4.26	4.64	5.02
P _{WL(E)01} (kN)	3.33	3.33	3.33	3.33	3.33
P _{FL01} (kN)	1.31	1.45	1.60	1.74	1.88
P _{FL02} (kN)	2.62	2.91	3.19	3.48	3.76
P ₀₁ (kN)	8.13	8.65	9.18	9.70	10.22
P ₀₂ (kN)	2.62	2.91	3.19	3.48	3.76
W ₀₁ (kN/m)	0.65	0.65	0.65	0.65	0.65
Span (m)	5.60	6.10	6.60	7.10	7.60
X1	0.50	0.50	0.50	0.50	0.50
X2	2.80	3.05	3.30	3.55	3.80
X3	5.10	5.60	6.10	6.60	7.10
R-01	10.94	11.77	12.59	13.42	14.25
R-02	10.94	11.77	12.59	13.42	14.25
Section - 2No	152x89x16UB	152x89x16UB	152x89x16UB	152x152x23UC	152x152x23UC

STRUCTURAL CALCULATION



Hibbert Smith Consulting Ltd – Structural & Civil Engineers
T: 07949 171 787 W: www.HibbertSmith.com

Project Ref	P22-0006.128				Project Title	Generic Mobile Home Lifting											
Doc Ref	P22-0006-HSC-Ca-S-128				Doc Title	Generic Mobile Home Lifting Assessment											
Version No	01	Date	Aug 23	Calcs By:	RJS	Date	Aug 23	Check By:	RS	Date	Aug 23	Appr'd By:	RJS	Sheet No	17	Sheet Version	01

Flat Roof - Canopy	B-01	B-02	B-03	B-04	B-05
Depth (m)	4.60	5.10	5.60	6.10	6.60
Needle Space (m)	1.90	1.90	1.90	1.90	1.90
W(RF-Flat) (kN/m ²)	0.80	0.80	0.80	0.80	0.80
W(FL) (kN/m ²)	0.60	0.60	0.60	0.60	0.60
W(WL-ext) (kN/m)	1.75	1.75	1.75	1.75	1.75
W(WL-int) (kN/m)	0.65	0.65	0.65	0.65	0.65
PRF01 (kN)	4.56	4.94	5.32	5.70	6.08
PRF03 (kN)	3.50	3.88	4.26	4.64	5.02
PWL(E)01 (kN)	3.33	3.33	3.33	3.33	3.33
PFL01 (kN)	1.31	1.45	1.60	1.74	1.88
PFL02 (kN)	2.62	2.91	3.19	3.48	3.76
P01 (kN)	9.20	9.72	10.24	10.76	11.29
P02 (kN)	2.62	2.91	3.19	3.48	3.76
P03 (kN)	8.13	8.65	9.18	9.70	10.22
W01 (kN/m)	0.65	0.65	0.65	0.65	0.65
Span (m)	6.30	6.80	7.30	7.80	8.30
X1	1.20	1.20	1.20	1.20	1.20
X2	3.50	3.75	4.00	4.25	4.50
X3	5.80	6.30	6.80	7.30	7.80
R-01	11.00	11.85	12.70	13.54	14.38
R-02	13.00	13.81	14.62	15.43	16.24
Section - 2No	152x152x23UC	152x152x23UC	152x152x23UC	152x152x30UC	152x152x30UC

STRUCTURAL CALCULATION



Hibbert Smith Consulting Ltd – Structural & Civil Engineers
T: 07949 171 787 W: www.HibbertSmith.com

Project Ref	P22-0006.128				Project Title	Generic Mobile Home Lifting											
Doc Ref	P22-0006-HSC-Ca-S-128				Doc Title	Generic Mobile Home Lifting Assessment											
Version No	01	Date	Aug 23	Calcs By:	RJS	Date	Aug 23	Check By:	RS	Date	Aug 23	Appr'd By:	RJS	Sheet No	18	Sheet Version	01

Pitched Roof	C-01	C-02	C-03	C-04	C-05
Depth (m)	4.60	5.10	5.60	6.10	6.60
Needle Space (m)	1.90	1.90	1.90	1.90	1.90
W(RF-Flat) (kN/m ²)	0.95	0.95	0.95	0.95	0.95
W(FL) (kN/m ²)	0.60	0.60	0.60	0.60	0.60
W(WL-ext) (kN/m)	1.75	1.75	1.75	1.75	1.75
W(WL-int) (kN/m)	0.65	0.65	0.65	0.65	0.65
PRF01 (kN)	4.15	4.60	5.05	5.51	5.96
PWL(E)01 (kN)	3.33	3.33	3.33	3.33	3.33
PFL01 (kN)	1.31	1.45	1.60	1.74	1.88
PFL02 (kN)	2.62	2.91	3.19	3.48	3.76
P01 (kN)	8.79	9.38	9.98	10.57	11.16
P02 (kN)	2.62	2.91	3.19	3.48	3.76
W01 (kN/m)	0.65	0.65	0.65	0.65	0.65
Span (m)	5.60	6.10	6.60	7.10	7.60
X1	0.50	0.50	0.50	0.50	0.50
X2	2.80	3.05	3.30	3.55	3.80
X3	5.10	5.60	6.10	6.60	7.10
R-01	11.59	12.49	13.39	14.29	15.19
R-02	11.59	12.49	13.39	14.29	15.19
Section - 2No	152x89x16UB	152x89x16UB	152x89x16UB	152x152x23UC	152x152x23UC

STRUCTURAL CALCULATION



Hibbert Smith Consulting Ltd – Structural & Civil Engineers
T: 07949 171 787 W: www.HibbertSmith.com

Project Ref	P22-0006.128				Project Title	Generic Mobile Home Lifting											
Doc Ref	P22-0006-HSC-Ca-S-128				Doc Title	Generic Mobile Home Lifting Assessment											
Version No	01	Date	Aug 23	Calcs By:	RJS	Date	Aug 23	Check By:	RS	Date	Aug 23	Appr'd By:	RJS	Sheet No	19	Sheet Version	01

Flat Roof - No Canopy	A-06	A-07	A-08	A-09	A-10
Depth (m)	4.60	5.10	5.60	6.10	6.60
Needle Space (m)	2.30	2.30	2.30	2.30	2.30
W(RF-Flat) (kN/m ²)	0.80	0.80	0.80	0.80	0.80
W(FL) (kN/m ²)	0.60	0.60	0.60	0.60	0.60
W(WL-ext) (kN/m)	1.75	1.75	1.75	1.75	1.75
W(WL-int) (kN/m)	0.65	0.65	0.65	0.65	0.65
PRF01 (kN)	4.23	4.69	5.15	5.61	6.07
PWL(E)01 (kN)	4.03	4.03	4.03	4.03	4.03
PFL01 (kN)	1.59	1.76	1.93	2.10	2.28
PFL02 (kN)	3.17	3.52	3.86	4.21	4.55
P01 (kN)	9.84	10.48	11.11	11.74	12.37
P02 (kN)	3.17	3.52	3.86	4.21	4.55
W01 (kN/m)	0.65	0.65	0.65	0.65	0.65
Span (m)	5.60	6.10	6.60	7.10	7.60
X1	0.50	0.50	0.50	0.50	0.50
X2	2.80	3.05	3.30	3.55	3.80
X3	5.10	5.60	6.10	6.60	7.10
R-01	12.93	13.89	14.86	15.83	16.80
R-02	12.93	13.89	14.86	15.83	16.80
Section - 2No	152x89x16UB	152x89x16UB	152x152x23UC	152x152x23UC	152x152x30UC

STRUCTURAL CALCULATION



Hibbert Smith Consulting Ltd – Structural & Civil Engineers
T: 07949 171 787 W: www.HibbertSmith.com

Project Ref	P22-0006.128				Project Title	Generic Mobile Home Lifting											
Doc Ref	P22-0006-HSC-Ca-S-128				Doc Title	Generic Mobile Home Lifting Assessment											
Version No	01	Date	Aug 23	Calcs By:	RJS	Date	Aug 23	Check By:	RS	Date	Aug 23	Appr'd By:	RJS	Sheet No	20	Sheet Version	01

Flat Roof - Canopy	B-06	B-07	B-08	B-09	B-10
Depth (m)	4.60	5.10	5.60	6.10	6.60
Needle Space (m)	2.30	2.30	2.30	2.30	2.30
W(RF-Flat) (kN/m ²)	0.80	0.80	0.80	0.80	0.80
W(FL) (kN/m ²)	0.60	0.60	0.60	0.60	0.60
W(WL-ext) (kN/m)	1.75	1.75	1.75	1.75	1.75
W(WL-int) (kN/m)	0.65	0.65	0.65	0.65	0.65
PRF01 (kN)	5.52	5.98	6.44	6.90	7.36
PRF03 (kN)	4.23	4.69	5.15	5.61	6.07
PWL(E)01 (kN)	4.03	4.03	4.03	4.03	4.03
PFL01 (kN)	1.59	1.76	1.93	2.10	2.28
PFL02 (kN)	3.17	3.52	3.86	4.21	4.55
P01 (kN)	11.13	11.76	12.40	13.03	13.66
P02 (kN)	3.17	3.52	3.86	4.21	4.55
P03 (kN)	9.84	10.48	11.11	11.74	12.37
W01 (kN/m)	0.65	0.65	0.65	0.65	0.65
Span (m)	6.30	6.80	7.30	7.80	8.30
X1	1.20	1.20	1.20	1.20	1.20
X2	3.50	3.75	4.00	4.25	4.50
X3	5.80	6.30	6.80	7.30	7.80
R-01	12.97	13.96	14.95	15.94	16.92
R-02	15.46	16.40	17.35	18.30	19.25
Section - 2No	152x152x23UC	152x152x23UC	152x152x30UC	152x152x30UC	152x152x37UC

STRUCTURAL CALCULATION



Hibbert Smith Consulting Ltd – Structural & Civil Engineers
T: 07949 171 787 W: www.HibbertSmith.com

Project Ref	P22-0006.128				Project Title	Generic Mobile Home Lifting											
Doc Ref	P22-0006-HSC-Ca-S-128				Doc Title	Generic Mobile Home Lifting Assessment											
Version No	01	Date	Aug 23	Calcs By:	RJS	Date	Aug 23	Check By:	RS	Date	Aug 23	Appr'd By:	RJS	Sheet No	21	Sheet Version	01

Pitched Roof	C-06	C-07	C-08	C-09	C-10
Depth (m)	4.60	5.10	5.60	6.10	6.60
Needle Space (m)	2.30	2.30	2.30	2.30	2.30
W(RF-Flat) (kN/m ²)	0.95	0.95	0.95	0.95	0.95
W(FL) (kN/m ²)	0.60	0.60	0.60	0.60	0.60
W(WL-ext) (kN/m)	1.75	1.75	1.75	1.75	1.75
W(WL-int) (kN/m)	0.65	0.65	0.65	0.65	0.65
PRF01 (kN)	5.03	5.57	6.12	6.66	7.21
PWL(E)01 (kN)	4.03	4.03	4.03	4.03	4.03
PFL01 (kN)	1.59	1.76	1.93	2.10	2.28
PFL02 (kN)	3.17	3.52	3.86	4.21	4.55
P01 (kN)	10.64	11.36	12.08	12.79	13.51
P02 (kN)	3.17	3.52	3.86	4.21	4.55
W01 (kN/m)	0.65	0.65	0.65	0.65	0.65
Span (m)	5.60	6.10	6.60	7.10	7.60
X1	0.50	0.50	0.50	0.50	0.50
X2	2.80	3.05	3.30	3.55	3.80
X3	5.10	5.60	6.10	6.60	7.10
R-01	13.72	14.77	15.83	16.88	17.93
R-02	13.72	14.77	15.83	16.88	17.93
Section - 2No	152x89x16UB	152x89x16UB	152x152x23UC	152x152x23UC	152x152x30UC

STRUCTURAL CALCULATION



Hibbert Smith Consulting Ltd – Structural & Civil Engineers
T: 07949 171 787 W: www.HibbertSmith.com

Project Ref	P22-0006.128				Project Title	Generic Mobile Home Lifting											
Doc Ref	P22-0006-HSC-Ca-S-128				Doc Title	Generic Mobile Home Lifting Assessment											
Version No	01	Date	Aug 23	Calcs By:	RJS	Date	Aug 23	Check By:	RS	Date	Aug 23	Appr'd By:	RJS	Sheet No	22	Sheet Version	01

Edge Beam Loading Analysis & Beam Design

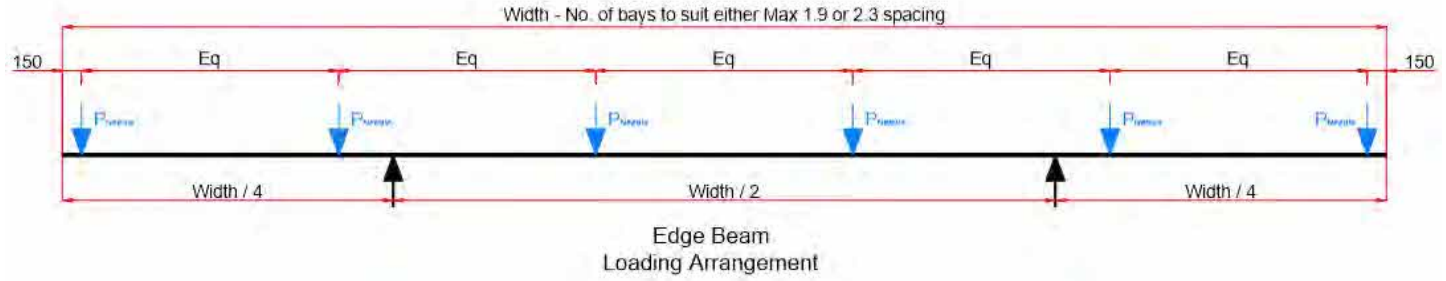

P_{needle} to be taken as R-02 from the relevant Needle loading case. To reduce the number of cases assessed, the load from the Maximum width will be taken ie Load Cases A-05, B-05, C-05, A-10, B-10 & C10. Edge beams will be assessed for cases with Max Cassette widths of 1.9m & 2.3m

As with the needle assessment, Case A refers to Flat roof with No Canopy, Case B refers to Flat roof with Canopy & Case C refers to a pitched roof.

STRUCTURAL CALCULATION



Hibbert Smith Consulting Ltd – Structural & Civil Engineers
T: 07949 171 787 W: www.HibbertSmith.com

Project Ref	P22-0006.128				Project Title	Generic Mobile Home Lifting											
Doc Ref	P22-0006-HSC-Ca-S-128				Doc Title	Generic Mobile Home Lifting Assessment											
Version No	01	Date	Aug 23	Calcs By:	RJS	Date	Aug 23	Check By:	RS	Date	Aug 23	Appr'd By:	RJS	Sheet No	23	Sheet Version	01

Max 1.9m Cassette Width						Case A		Case B		Case C	
Case Ref	Edge Beam Span (m)	No Cassettes	Cassette Width (m)	Span A (m)	Span B (m)	Needle Load (kN) (A-05)	Section	Needle Load (kN) (B-05)	Section	Needle Load (kN) (C-05)	Section
100	7.05	4	1.69	1.76	3.53	14.25	150x75 PFC	16.24	150x75 PFC	15.19	150x75 PFC
101	8.05	5	1.55	2.01	4.03	14.25	150x75 PFC	16.24	150x75 PFC	15.19	150x75 PFC
102	8.55	5	1.65	2.14	4.28	14.25	150x75 PFC	16.24	150x75 PFC	15.19	150x75 PFC
103	9.05	5	1.75	2.26	4.53	14.25	150x75 PFC	16.24	150x75 PFC	15.19	150x75 PFC
104	9.55	5	1.85	2.39	4.78	14.25	150x75 PFC	16.24	150x75 PFC	15.19	150x75 PFC
105	10.05	6	1.63	2.51	5.03	14.25	180x75 PFC	16.24	200x75 PFC	15.19	200x75 PFC
106	10.55	6	1.71	2.64	5.28	14.25	200x75 PFC	16.24	200x75 PFC	15.19	200x75 PFC
107	11.05	6	1.79	2.76	5.53	14.25	200x75 PFC	16.24	200x75 PFC	15.19	200x75 PFC
108	12.05	7	1.68	3.01	6.03	14.25	200x75 PFC	16.24	230x75 PFC	15.19	230x75 PFC
109	12.55	7	1.75	3.14	6.28	14.25	230x75 PFC	16.24	260x75 PFC	15.19	230x75 PFC
110	13.05	7	1.82	3.26	6.53	14.25	230x75 PFC	16.24	230x90 PFC	15.19	260x75 PFC
111	13.55	7	1.89	3.39	6.78	14.25	200x90 PFC	16.24	230x90 PFC	15.19	200x90 PFC

Max 2.3m Cassette Width						Case A		Case B		Case C	
Case Ref	Edge Beam Span (m)	No Cassettes	Cassette Width (m)	Span A (m)	Span B (m)	Needle Load (kN) (A-10)	Section	Needle Load (kN) (B-10)	Section	Needle Load (kN) (C-10)	Section
200	7.05	3	2.25	1.76	3.53	16.80	150x75 PFC	19.25	150x75 PFC	17.93	150x75 PFC
201	8.05	4	1.94	2.01	4.03	16.80	150x75 PFC	19.25	150x75 PFC	17.93	150x75 PFC
202	8.55	4	2.06	2.14	4.28	16.80	150x75 PFC	19.25	150x75 PFC	17.93	150x75 PFC
203	9.05	4	2.19	2.26	4.53	16.80	150x75 PFC	19.25	150x75 PFC	17.93	150x75 PFC
204	9.55	4	2.31	2.39	4.78	16.90	150x75 PFC	19.25	150x75 PFC	17.93	150x75 PFC
205	10.05	5	1.95	2.51	5.03	16.80	180x75 PFC	19.25	180x75 PFC	17.93	180x75 PFC
206	10.55	5	2.05	2.64	5.28	16.80	200x75 PFC	19.25	200x75 PFC	17.93	200x75 PFC
207	11.05	5	2.15	2.76	5.53	16.80	200x75 PFC	19.25	200x75 PFC	17.93	200x75 PFC
208	12.05	6	1.96	3.01	6.03	16.80	260x75 PFC	19.25	200x90 PFC	17.93	200x90 PFC
209	12.55	6	2.04	3.14	6.28	16.80	200x90 PFC	19.25	230x90 PFC	17.93	200x90 PFC
210	13.05	6	2.13	3.26	6.53	16.80	200x90 PFC	19.25	230x90 PFC	17.93	200x90 PFC
211	13.55	6	2.21	3.39	6.78	16.80	200x90 PFC	19.25	230x90 PFC	17.93	200x90 PFC

STRUCTURAL CALCULATION



Hibbert Smith Consulting Ltd – Structural & Civil Engineers
T: 07949 171 787 W: www.HibbertSmith.com

Project Ref	P22-0006.128				Project Title	Generic Mobile Home Lifting											
Doc Ref	P22-0006-HSC-Ca-S-128				Doc Title	Generic Mobile Home Lifting Assessment											
Version No	01	Date	Aug 23	Calcs By:	RJS	Date	Aug 23	Check By:	RS	Date	Aug 23	Appr'd By:	RJS	Sheet No	24	Sheet Version	01

Secondary Beam Design

The Secondary Beam applied loading will be based on the total building weight. To limit the number of loading cases considered the weight will be based on the Maximum overall depth for Cases A, B & C. Secondary Beam Spans for all available building widths will be considered.

For simplicity, weight due to internal partition walls will be taken as 0.25 kN/m²

Allow 30% of Self weight for Lifting Frame

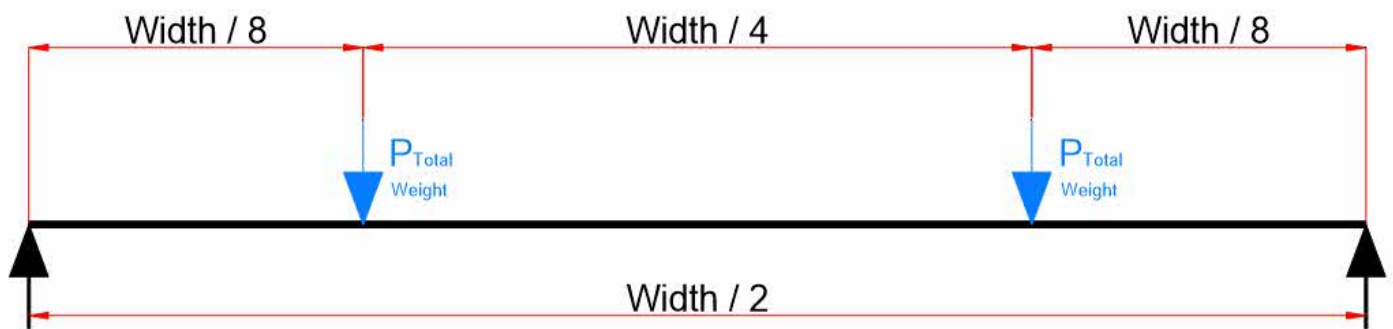

Secondary Beam Loading Arrangement

Case A

Case Ref	Width(m)	Depth(m)	Roof (kN)	Floor (kN)	Ext Wall (kN)	Int Wall (kN)	Frame SWT (kN)	Total (kN)	Sec Beam Span (m)	Point Load (kN)	Load Position 1 (m)	Load Position 2 (m)	Steel Section
A-300	7.05	6.55	36.94	27.71	47.60	11.54	37.14	160.93	3.525	40.23	0.881	2.644	203x133x30UB
A-301	8.05	6.55	42.18	31.64	51.10	13.18	41.43	179.53	4.025	44.88	1.006	3.019	254x146x31UB
A-302	8.55	6.55	44.80	33.60	52.85	14.00	43.58	188.83	4.275	47.21	1.069	3.206	254x146x37UB
A-303	9.05	6.55	47.42	35.57	54.60	14.82	45.72	198.13	4.525	49.53	1.131	3.394	254x146x37UB
A-304	9.55	6.55	50.04	37.53	56.35	15.64	47.87	207.43	4.775	51.86	1.194	3.581	254x146x43UB
A-305	10.05	6.55	52.66	39.50	58.10	16.46	50.01	216.73	5.025	54.18	1.256	3.769	305x165x40UB
A-306	10.55	6.55	55.28	41.46	59.85	17.28	52.16	226.03	5.275	56.51	1.319	3.956	305x165x46UB
A-307	11.05	6.55	57.90	43.43	61.60	18.09	54.31	235.33	5.525	58.83	1.381	4.144	305x165x46UB
A-308	12.05	6.55	63.14	47.36	65.10	19.73	58.60	253.93	6.025	63.48	1.506	4.519	356x171x57UB
A-309	12.55	6.55	65.76	49.32	66.85	20.55	60.75	263.23	6.275	65.81	1.569	4.706	406x178x60UB
A-310	13.05	6.55	68.38	51.29	68.60	21.37	62.89	272.53	6.525	68.13	1.631	4.894	406x178x67UB
A-311	13.55	6.55	71.00	53.25	70.35	22.19	65.04	281.83	6.775	70.46	1.694	5.081	457x191x67UB

STRUCTURAL CALCULATION



Hibbert Smith Consulting Ltd – Structural & Civil Engineers
T: 07949 171 787 W: www.HibbertSmith.com

Project Ref	P22-0006.128				Project Title	Generic Mobile Home Lifting											
Doc Ref	P22-0006-HSC-Ca-S-128				Doc Title	Generic Mobile Home Lifting Assessment											
Version No	01	Date	Aug 23	Calcs By:	RJS	Date	Aug 23	Check By:	RS	Date	Aug 23	Appr'd By:	RJS	Sheet No	25	Sheet Version	01

Case B

Case Ref	Width(m)	Depth(m)	Roof (kN)	Floor (kN)	Ext Wall (kN)	Int Wall (kN)	Frame SWT (kN)	Total (kN)	Sec Beam Span (m)	Point Load (kN)	Load Position 1 (m)	Load Position 2 (m)	Steel Section
B-300	7.05	6.55	40.9	27.7	47.6	11.5	38.32	166.06	3.525	41.52	0.881	2.644	203x133x30UB
B-301	8.05	6.55	46.7	31.6	51.1	13.2	42.78	185.39	4.025	46.35	1.006	3.019	254x146x31UB
B-302	8.55	6.55	49.6	33.6	52.9	14.0	45.01	195.05	4.275	48.76	1.069	3.206	254x146x37UB
B-303	9.05	6.55	52.5	35.6	54.6	14.8	47.24	204.72	4.525	51.18	1.131	3.394	254x146x37UB
B-304	9.55	6.55	55.4	37.5	56.4	15.6	49.47	214.38	4.775	53.60	1.194	3.581	254x146x43UB
B-305	10.05	6.55	58.3	39.5	58.1	16.5	51.70	224.05	5.025	56.01	1.256	3.769	305x165x40UB
B-306	10.55	6.55	61.2	41.5	59.9	17.3	53.93	233.71	5.275	58.43	1.319	3.956	305x165x46UB
B-307	11.05	6.55	64.1	43.4	61.6	18.1	56.16	243.37	5.525	60.84	1.381	4.144	356x171x51UB
B-308	12.05	6.55	69.9	47.4	65.1	19.7	60.62	262.70	6.025	65.68	1.506	4.519	406x178x60UB
B-309	12.55	6.55	72.8	49.3	66.9	20.6	62.85	272.37	6.275	68.09	1.569	4.706	406x178x67UB
B-310	13.05	6.55	75.7	51.3	68.6	21.4	65.08	282.03	6.525	70.51	1.631	4.894	406x178x67UB
B-311	13.55	6.55	78.6	53.3	70.4	22.2	67.31	291.69	6.775	72.92	1.694	5.081	406x178x74UB

Case C

Case Ref	Width(m)	Depth(m)	Roof (kN)	Floor (kN)	Ext Wall (kN)	Int Wall (kN)	Frame SWT (kN)	Total (kN)	Sec Beam Span (m)	Point Load (kN)	Load Position 1 (m)	Load Position 2 (m)	Steel Section
C-300	7.05	6.55	43.87	27.71	47.60	11.54	39.22	169.94	3.525	42.48	0.881	2.644	203x133x30UB
C-301	8.05	6.55	50.09	31.64	51.10	13.18	43.80	189.81	4.025	47.45	1.006	3.019	254x146x31UB
C-302	8.55	6.55	53.20	33.60	52.85	14.00	46.10	199.75	4.275	49.94	1.069	3.206	254x146x37UB
C-303	9.05	6.55	56.31	35.57	54.60	14.82	48.39	209.69	4.525	52.42	1.131	3.394	254x146x37UB
C-304	9.55	6.55	59.42	37.53	56.35	15.64	50.68	219.63	4.775	54.91	1.194	3.581	254x146x43UB
C-305	10.05	6.55	62.54	39.50	58.10	16.46	52.98	229.57	5.025	57.39	1.256	3.769	305x165x40UB
C-306	10.55	6.55	65.65	41.46	59.85	17.28	55.27	239.50	5.275	59.88	1.319	3.956	305x165x46UB
C-307	11.05	6.55	68.76	43.43	61.60	18.09	57.56	249.44	5.525	62.36	1.381	4.144	356x171x51UB
C-308	12.05	6.55	74.98	47.36	65.10	19.73	62.15	269.32	6.025	67.33	1.506	4.519	406x178x60UB
C-309	12.55	6.55	78.09	49.32	66.85	20.55	64.44	279.26	6.275	69.81	1.569	4.706	406x178x67UB
C-310	13.05	6.55	81.20	51.29	68.60	21.37	66.74	289.20	6.525	72.30	1.631	4.894	406x178x67UB
C-311	13.55	6.55	84.31	53.25	70.35	22.19	69.03	299.14	6.775	74.78	1.694	5.081	406x178x74UB

STRUCTURAL CALCULATION



Hibbert Smith Consulting Ltd – Structural & Civil Engineers
T: 07949 171 787 W: www.HibbertSmith.com

Project Ref	P22-0006.128				Project Title	Generic Mobile Home Lifting											
Doc Ref	P22-0006-HSC-Ca-S-128				Doc Title	Generic Mobile Home Lifting Assessment											
Version No	01	Date	Aug 23	Calcs By:	RJS	Date	Aug 23	Check By:	RS	Date	Aug 23	Appr'd By:	RJS	Sheet No	26	Sheet Version	01

Primary Beam Design

Primary Beam Design will be based on the maximum spans of 7.6m for Cases A & C and 8.3m for Case B. Loading will be based on the total building weight as calculated for the Secondary Beams. As with the secondary beams all building widths will be considered.

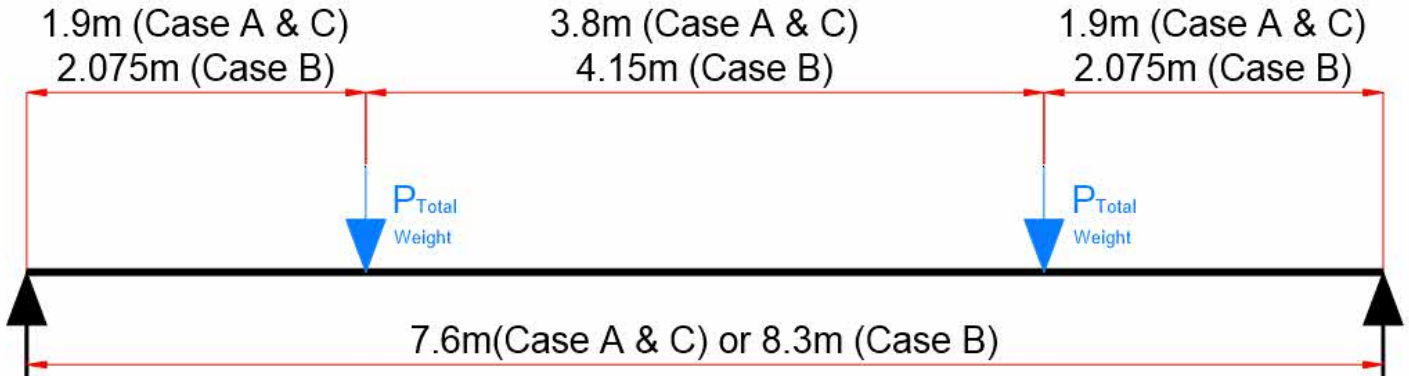

Primary Beam Loading Arrangement

Case A

Case Ref	Width (m)	Depth (m)	Roof (kN)	Floor (kN)	Ext Wall (kN)	Int Wall (kN)	Frame SWT (kN)	Total (kN)	Prim Beam Span (m)	Point Load (kN)	Load Position 1 (m)	Load Position 2 (m)	Steel Section
A-400	7.05	6.55	36.94	27.71	47.60	11.54	37.14	160.93	7.6	40.23	1.900	5.700	406x178x60UB
A-401	8.05	6.55	42.18	31.64	51.10	13.18	41.43	179.53	7.6	44.88	1.900	5.700	406x178x60UB
A-402	8.55	6.55	44.80	33.60	52.85	14.00	43.58	188.83	7.6	47.21	1.900	5.700	406x178x67UB
A-403	9.05	6.55	47.42	35.57	54.60	14.82	45.72	198.13	7.6	49.53	1.900	5.700	406x178x67UB
A-404	9.55	6.55	50.04	37.53	56.35	15.64	47.87	207.43	7.6	51.86	1.900	5.700	406x178x67UB
A-405	10.05	6.55	52.66	39.50	58.10	16.46	50.01	216.73	7.6	54.18	1.900	5.700	457x191x67UB
A-406	10.55	6.55	55.28	41.46	59.85	17.28	52.16	226.03	7.6	56.51	1.900	5.700	406x178x74UB
A-407	11.05	6.55	57.90	43.43	61.60	18.09	54.31	235.33	7.6	58.83	1.900	5.700	406x178x74UB
A-408	12.05	6.55	63.14	47.36	65.10	19.73	58.60	253.93	7.6	63.48	1.900	5.700	406x178x74UB
A-409	12.55	6.55	65.76	49.32	66.85	20.55	60.75	263.23	7.6	65.81	1.900	5.700	457x191x74UB
A-410	13.05	6.55	68.38	51.29	68.60	21.37	62.89	272.53	7.6	68.13	1.900	5.700	457x191x82UB
A-411	13.55	6.55	71.00	53.25	70.35	22.19	65.04	281.83	7.6	70.46	1.900	5.700	457x191x82UB

STRUCTURAL CALCULATION



Hibbert Smith Consulting Ltd – Structural & Civil Engineers
T: 07949 171 787 W: www.HibbertSmith.com

Project Ref	P22-0006.128				Project Title	Generic Mobile Home Lifting											
Doc Ref	P22-0006-HSC-Ca-S-128				Doc Title	Generic Mobile Home Lifting Assessment											
Version No	01	Date	Aug 23	Calcs By:	RJS	Date	Aug 23	Check By:	RS	Date	Aug 23	Apprd By:	RJS	Sheet No	27	Sheet Version	01

Case B

Case Ref	Width(m)	Depth(m)	Roof (kN)	Floor (kN)	Ext Wall (kN)	Int Wall (kN)	Frame SWT (kN)	Total (kN)	Prim Beam Span (m)	Point Load (kN)	Load Position 1 (m)	Load Position 2 (m)	Steel Section
B-400	7.05	6.55	40.9	27.7	47.6	11.5	38.32	166.06	8.3	41.52	2.075	6.225	406x178x67UB
B-401	8.05	6.55	46.7	31.6	51.1	13.2	42.78	185.39	8.3	46.35	2.075	6.225	406x178x74UB
B-402	8.55	6.55	49.6	33.6	52.9	14.0	45.01	195.05	8.3	48.76	2.075	6.225	406x178x74UB
B-403	9.05	6.55	52.5	35.6	54.6	14.8	47.24	204.72	8.3	51.18	2.075	6.225	406x178x74UB
B-404	9.55	6.55	55.4	37.5	56.4	15.6	49.47	214.38	8.3	53.60	2.075	6.225	457x191x74UB
B-405	10.05	6.55	58.3	39.5	58.1	16.5	51.70	224.05	8.3	56.01	2.075	6.225	457x191x82UB
B-406	10.55	6.55	61.2	41.5	59.9	17.3	53.93	233.71	8.3	58.43	2.075	6.225	457x191x82UB
B-407	11.05	6.55	64.1	43.4	61.6	18.1	56.16	243.37	8.3	60.84	2.075	6.225	457x191x82UB
B-408	12.05	6.55	69.9	47.4	65.1	19.7	60.62	262.70	8.3	65.68	2.075	6.225	533x210x82UB
B-409	12.55	6.55	72.8	49.3	66.9	20.6	62.85	272.37	8.3	68.09	2.075	6.225	457x191x89UB
B-410	13.05	6.55	75.7	51.3	68.6	21.4	65.08	282.03	8.3	70.51	2.075	6.225	457x191x89UB
B-411	13.55	6.55	78.6	53.3	70.4	22.2	67.31	291.69	8.3	72.92	2.075	6.225	457x191x89UB

Case C

Case Ref	Width(m)	Depth(m)	Roof (kN)	Floor (kN)	Ext Wall (kN)	Int Wall (kN)	Frame SWT (kN)	Total (kN)	Prim Beam Span (m)	Point Load (kN)	Load Position 1 (m)	Load Position 2 (m)	Steel Section
C-400	7.05	6.55	43.87	27.71	47.60	11.54	39.22	169.94	7.6	42.48	1.900	5.700	406x178x60UB
C-401	8.05	6.55	50.09	31.64	51.10	13.18	43.80	189.81	7.6	47.45	1.900	5.700	406x178x67UB
C-402	8.55	6.55	53.20	33.60	52.85	14.00	46.10	199.75	7.6	49.94	1.900	5.700	406x178x67UB
C-403	9.05	6.55	56.31	35.57	54.60	14.82	48.39	209.69	7.6	52.42	1.900	5.700	406x178x67UB
C-404	9.55	6.55	59.42	37.53	56.35	15.64	50.68	219.63	7.6	54.91	1.900	5.700	457x191x67UB
C-405	10.05	6.55	62.54	39.50	58.10	16.46	52.98	229.57	7.6	57.39	1.900	5.700	406x178x74UB
C-406	10.55	6.55	65.65	41.46	59.85	17.28	55.27	239.50	7.6	59.88	1.900	5.700	406x178x74UB
C-407	11.05	6.55	68.76	43.43	61.60	18.09	57.56	249.44	7.6	62.36	1.900	5.700	406x178x74UB
C-408	12.05	6.55	74.98	47.36	65.10	19.73	62.15	269.32	7.6	67.33	1.900	5.700	457x191x82UB
C-409	12.55	6.55	78.09	49.32	66.85	20.55	64.44	279.26	7.6	69.81	1.900	5.700	457x191x82UB
C-410	13.05	6.55	81.20	51.29	68.60	21.37	66.74	289.20	7.6	72.30	1.900	5.700	457x191x82UB
C-411	13.55	6.55	84.31	53.25	70.35	22.19	69.03	299.14	7.6	74.78	1.900	5.700	457x191x82UB

STRUCTURAL CALCULATION



Hibbert Smith Consulting Ltd – Structural & Civil Engineers
T: 07949 171 787 W: www.HibbertSmith.com

Project Ref		P22-0006.128			Project Title		Generic Mobile Home Lifting								
Doc Ref		P22-0006-HSC-Ca-S-128			Doc Title		Generic Mobile Home Lifting Assessment								
Version No	Date	Calcs By:	RJS	Date	Aug 23	Check By:	RS	Date	Aug 23	Appr'd By:	RJS	Sheet No	28	Sheet Version	01

Columns & Bracing

Column & Bracing Design will be based on the worst case for Cases B & C

Case A & B

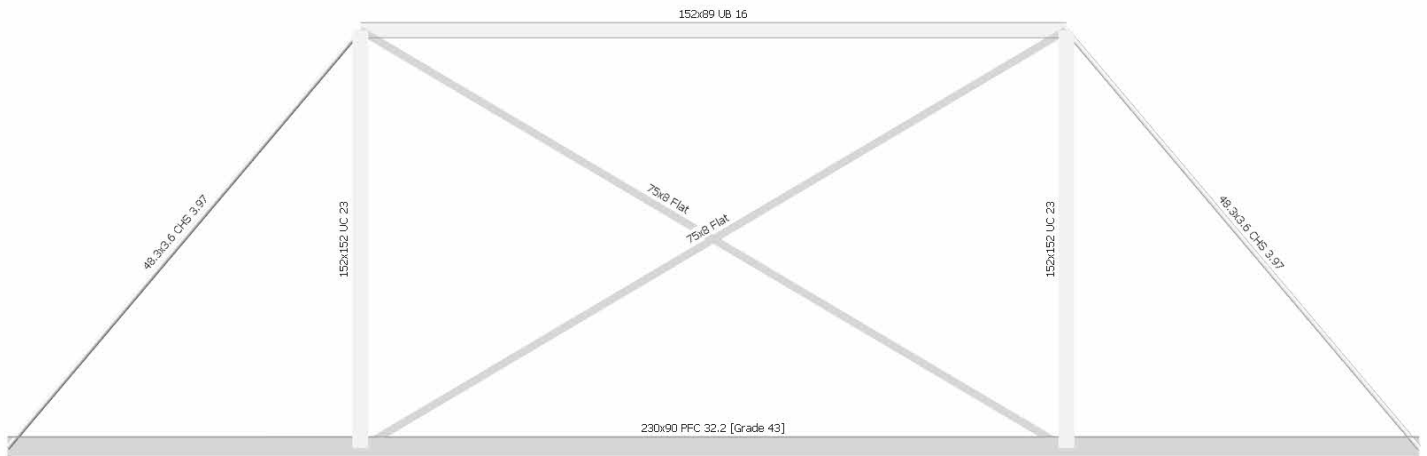
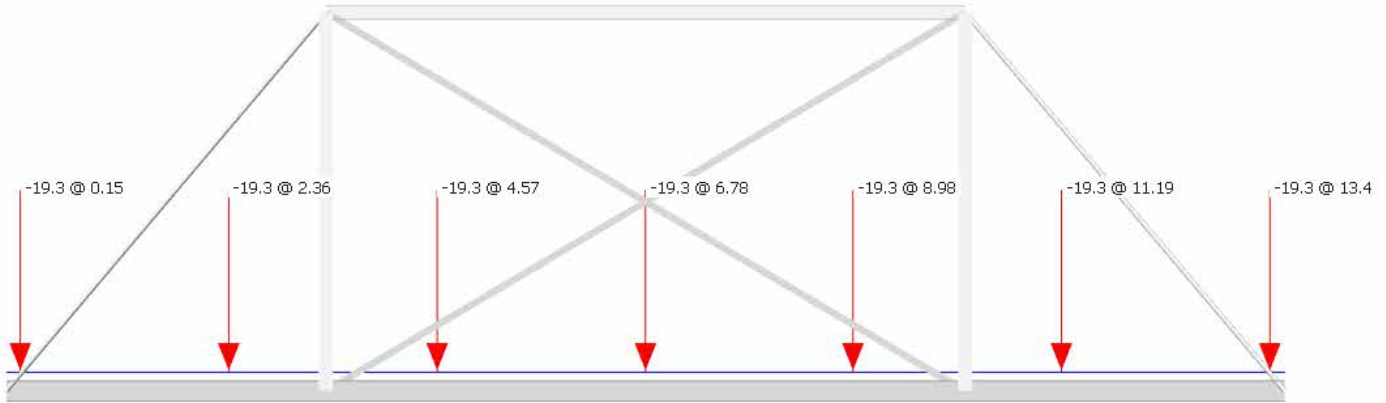

STRUCTURAL CALCULATION



Hibbert Smith Consulting Ltd – Structural & Civil Engineers
T: 07949 171 787 W: www.HibbertSmith.com

Project Ref		P22-0006.128			Project Title		Generic Mobile Home Lifting				
Doc Ref		P22-0006-HSC-Ca-S-128			Doc Title		Generic Mobile Home Lifting Assessment				
Version No	Date	Calcs By:	Date	Check By:	Date	Appr'd By:	Sheet No	Sheet Version			
01	Aug 23	RJS	Aug 23	RS	Aug 23	RJS	29	01			

Case C

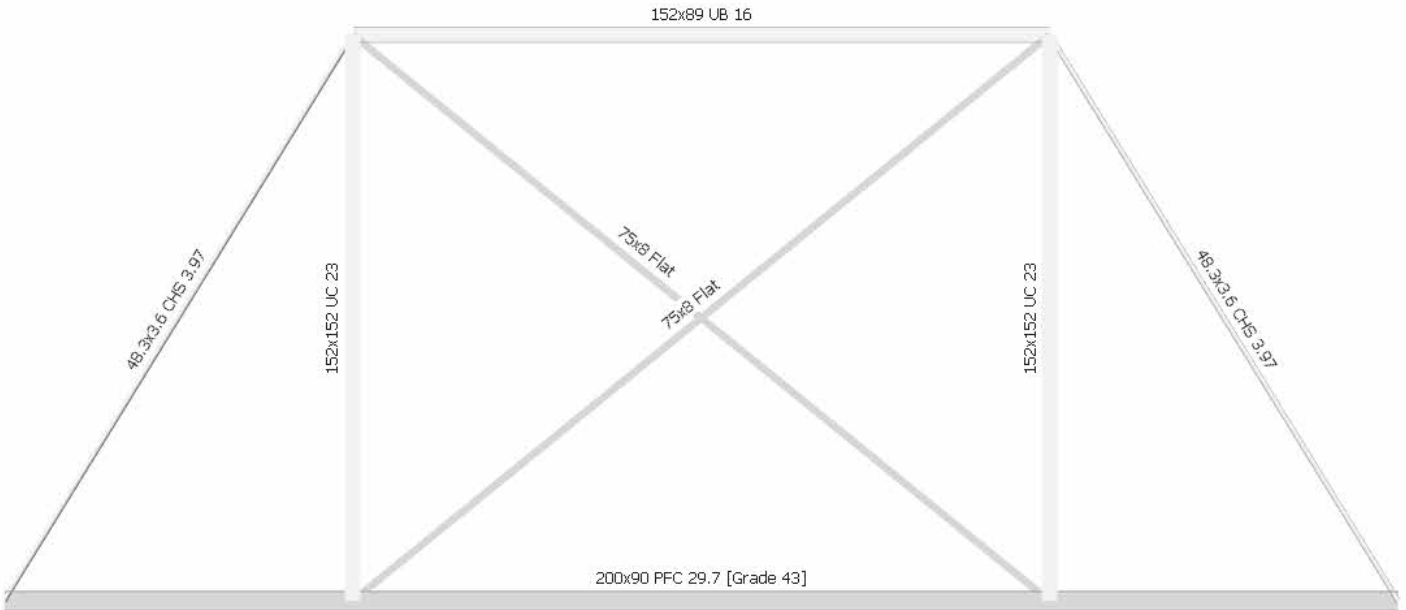
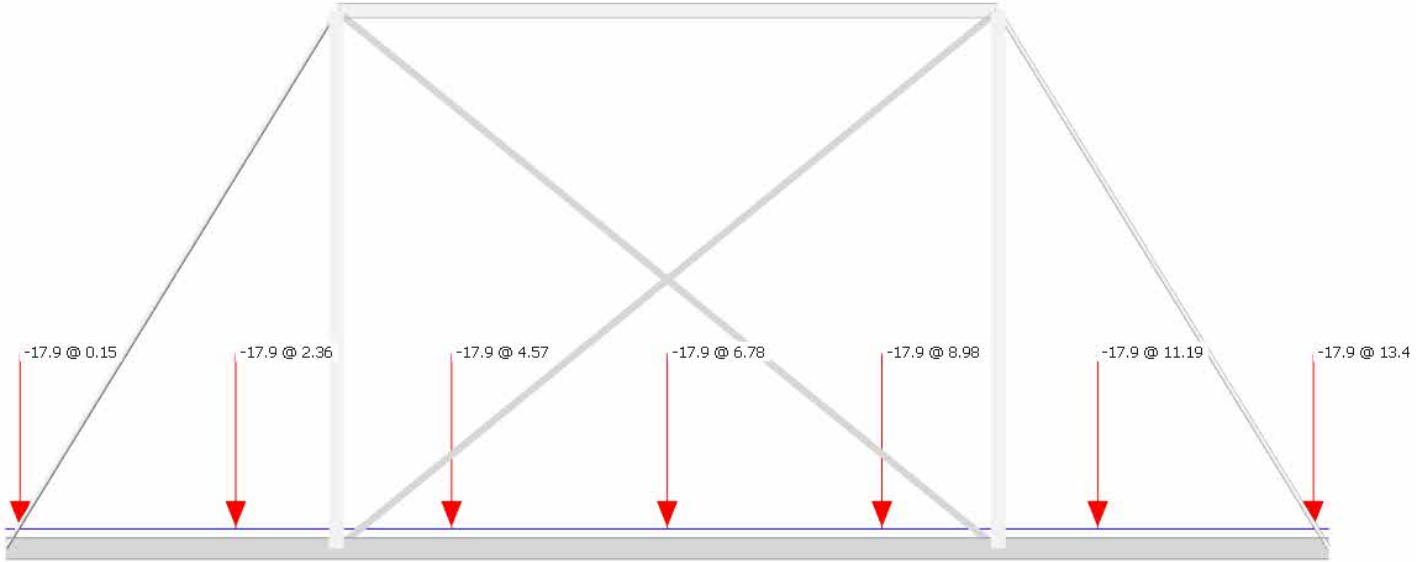

STRUCTURAL CALCULATION



Hibbert Smith Consulting Ltd – Structural & Civil Engineers
T: 07949 171 787 W: www.HibbertSmith.com

Project Ref		P22-0006.128				Project Title		Generic Mobile Home Lifting								
Doc Ref		P22-0006-HSC-Ca-S-128				Doc Title		Generic Mobile Home Lifting Assessment								
Version No	Date	Aug 23	Calcs By:	RJS	Date	Aug 23	Check By:	RS	Date	Aug 23	Apprd By:	RJS	Sheet No	30	Sheet Version	01

Lifting Frame Section Size Summary Tables

Constant Sections:

Column: 152x152x23 UC

Diagonal Brace: 48.3x3.6 CHS

Cross Brace: 75x8 Flat

Tie Beam: 152x89x16UB

Strut Beam: 203x133x25

Needle Tie: 152x89x16UB

Variable Sections by Building Type, Roof Type & Cassette Width

Case A - Flat Roof (No Canopy)- 1.9m Cassette Width

Building Name	Version	Overall Width (m)	Overall Depth (m)	Needle Beam (2No)	Edge Beam	Sec Beam	Prim Beam
The Bawtry (Ba)	Standard (S)	7.05	5.05	152x89x16UB	150x75PFC	203x133x30UB	406x178x60UB
	Extra (E)	8.05	6.05	152x152x23UC	150x75PFC	254x146x31UB	406x178x60UB
	Extra Plus (E+)	9.55	6.55	152x152x23UC	150x75PFC	254x146x43UB	406x178x67UB
The Cantley (Can)	Standard (S)	8.55	4.55	152x89x16UB	150x75PFC	254x146x37UB	406x178x67UB
	Extra (E)	9.55	4.55	152x89x16UB	150x75PFC	254x146x43UB	406x178x67UB
	Extra Plus (E+)	10.55	5.05	152x89x16UB	200x75PFC	305x165x46UB	406x178x74UB
The Ravenscroft (Ra)	Standard (S)	10.05	4.55	152x89x16UB	180x75PFC	305x165x40UB	457x191x67UB
	Extra (E)	12.05	5.05	152x89x16UB	200x75PFC	356x171x57UB	406x178x74UB
	Extra Plus (E+)	12.55	5.55	152x89x16UB	230x75PFC	406x178x60UB	457x191x74UB
The Dinscroft (Du)	Standard (S)	8.05	5.55	152x89x16UB	150x75PFC	254x146x31UB	406x178x60UB
	Extra (E)	9.05	6.05	152x152x23UC	150x75PFC	254x146x37UB	406x178x67UB
	Extra Plus (E+)	10.05	6.55	152x152x23UC	180x75PFC	305x165x40UB	457x191x67UB
The Hickleton (Hi)	Standard (S)	9.05	6.05	152x152x23UC	150x75PFC	254x146x37UB	406x178x67UB
	Extra (E)	10.05	6.55	152x152x23UC	180x75PFC	305x165x40UB	457x191x67UB
	Extra Plus (E+)	12.05	6.55	152x152x23UC	200x75PFC	356x171x57UB	406x178x74UB
The Melton (Me)	Standard (S)	12.05	4.55	152x89x16UB	200x75PFC	356x171x57UB	406x178x74UB
	Extra (E)	13.05	5.05	152x89x16UB	230x75PFC	406x178x67UB	457x191x82UB
	Extra Plus (E+)	13.55	5.55	152x89x16UB	200x90PFC	457x191x67UB	457x191x82UB
The Cadeby (Cad)	Standard (S)	9.55	5.05	152x89x16UB	150x75PFC	254x146x43UB	406x178x67UB
	Extra (E)	11.05	5.55	152x89x16UB	200x75PFC	305x165x46UB	406x178x74UB
	Extra Plus (E+)	12.55	6.05	152x152x23UC	230x75PFC	406x178x60UB	457x191x74UB
The Loversall (Lo)	Standard (S)	8.55	6.05	152x152x23UC	150x75PFC	254x146x37UB	406x178x67UB
	Extra (E)	10.05	6.55	152x152x23UC	180x75PFC	305x165x40UB	457x191x67UB
	Extra Plus (E+)	12.05	6.55	152x152x23UC	200x75PFC	356x171x57UB	406x178x74UB
The Hatfield (Ha)	Standard (S)	10.05	6.55	152x152x23UC	180x75PFC	305x165x40UB	457x191x67UB
	Extra (E)	11.05	6.55	152x152x23UC	200x75PFC	305x165x46UB	406x178x74UB
	Extra Plus (E+)	12.05	6.55	152x152x23UC	200x75PFC	356x171x57UB	406x178x74UB
The Wheatley (Wh)	Standard (S)	10.05	6.05	152x152x23UC	180x75PFC	305x165x40UB	457x191x67UB
	Extra (E)	12.05	6.55	152x152x23UC	200x75PFC	356x171x57UB	406x178x74UB
	Extra Plus (E+)	13.55	6.55	152x152x23UC	200x90PFC	457x191x67UB	457x191x82UB

STRUCTURAL CALCULATION



Project Ref	P22-0006.128				Project Title	Generic Mobile Home Lifting											
Doc Ref	P22-0006-HSC-Ca-S-128				Doc Title	Generic Mobile Home Lifting Assessment											
Version No	01	Date	Aug 23	Calcs By:	RJS	Date	Aug 23	Check By:	RS	Date	Aug 23	Apprd By:	RJS	Sheet No	31	Sheet Version	01

Case A - Flat Roof (No Canopy) - 2.3m Cassette Width

Building Name	Version	Overall Width (m)	Overall Depth (m)	Needle Beam (2No)	Edge Beam	Sec Beam	Prim Beam
The Bawtry (Ba)	Standard (S)	7.05	5.05	152x89x16UB	150x75PFC	203x133x30UB	406x178x60UB
	Extra (E)	8.05	6.05	152x152x23UC	150x75PFC	254x146x31UB	406x178x60UB
	Extra Plus (E+)	9.55	6.55	152x152x30UC	150x75PFC	254x146x43UB	406x178x67UB
The Cantley (Can)	Standard (S)	8.55	4.55	152x89x16UB	150x75PFC	254x146x37UB	406x178x67UB
	Extra (E)	9.55	4.55	152x89x16UB	150x75PFC	254x146x43UB	406x178x67UB
	Extra Plus (E+)	10.55	5.05	152x89x16UB	200x75PFC	305x165x46UB	406x178x74UB
The Ravenscroft (Ra)	Standard (S)	10.05	4.55	152x89x16UB	180x75PFC	305x165x40UB	457x191x67UB
	Extra (E)	12.05	5.05	152x89x16UB	260x75PFC	356x171x57UB	406x178x74UB
	Extra Plus (E+)	12.55	5.55	152x152x23UC	200x90PFC	406x178x60UB	457x191x74UB
The Dinscroft (Du)	Standard (S)	8.05	5.55	152x152x23UC	150x75PFC	254x146x31UB	406x178x60UB
	Extra (E)	9.05	6.05	152x152x23UC	150x75PFC	254x146x37UB	406x178x67UB
	Extra Plus (E+)	10.05	6.55	152x152x30UC	180x75PFC	305x165x40UB	457x191x67UB
The Hickleton (Hi)	Standard (S)	9.05	6.05	152x152x23UC	150x75PFC	254x146x37UB	406x178x67UB
	Extra (E)	10.05	6.55	152x152x30UC	180x75PFC	305x165x40UB	457x191x67UB
	Extra Plus (E+)	12.05	6.55	152x152x30UC	260x75PFC	356x171x57UB	406x178x74UB
The Melton (Me)	Standard (S)	12.05	4.55	152x89x16UB	260x75PFC	356x171x57UB	406x178x74UB
	Extra (E)	13.05	5.05	152x89x16UB	200x90PFC	406x178x67UB	457x191x82UB
	Extra Plus (E+)	13.55	5.55	152x152x23UC	200x90PFC	457x191x67UB	457x191x82UB
The Cadeby (Cad)	Standard (S)	9.55	5.05	152x89x16UB	150x75PFC	254x146x43UB	406x178x67UB
	Extra (E)	11.05	5.55	152x152x23UC	200x75PFC	305x165x46UB	406x178x74UB
	Extra Plus (E+)	12.55	6.05	152x152x23UC	200x90PFC	406x178x60UB	457x191x74UB
The Loversall (Lo)	Standard (S)	8.55	6.05	152x152x23UC	150x75PFC	254x146x37UB	406x178x67UB
	Extra (E)	10.05	6.55	152x152x30UC	180x75PFC	305x165x40UB	457x191x67UB
	Extra Plus (E+)	12.05	6.55	152x152x30UC	260x75PFC	356x171x57UB	406x178x74UB
The Hatfield (Ha)	Standard (S)	10.05	6.55	152x152x30UC	180x75PFC	305x165x40UB	457x191x67UB
	Extra (E)	11.05	6.55	152x152x30UC	200x75PFC	305x165x46UB	406x178x74UB
	Extra Plus (E+)	12.05	6.55	152x152x30UC	260x75PFC	356x171x57UB	406x178x74UB
The Wheatley (Wh)	Standard (S)	10.05	6.05	152x152x23UC	180x75PFC	305x165x40UB	457x191x67UB
	Extra (E)	12.05	6.55	152x152x30UC	260x75PFC	356x171x57UB	406x178x74UB
	Extra Plus (E+)	13.55	6.55	152x152x30UC	200x90PFC	457x191x67UB	457x191x82UB

STRUCTURAL CALCULATION



Hibbert Smith Consulting Ltd – Structural & Civil Engineers
T: 07949 171 787 W: www.HibbertSmith.com

Project Ref	P22-0006.128				Project Title	Generic Mobile Home Lifting											
Doc Ref	P22-0006-HSC-Ca-S-128				Doc Title	Generic Mobile Home Lifting Assessment											
Version No	01	Date	Aug 23	Calcs By:	RJS	Date	Aug 23	Check By:	RS	Date	Aug 23	Apprd By:	RJS	Sheet No	32	Sheet Version	01

Case B - Flat Roof (With Canopy) - 1.9m Cassette Width

Building Name	Version	Overall Width (m)	Overall Depth (m)	Needle Beam (2No)	Edge Beam	Sec Beam	Prim Beam
The Bawtry (Ba)	Standard (S)	7.05	5.05	152x152x23UC	150x75PFC	203x133x30UB	406x178x67UB
	Extra (E)	8.05	6.05	152x152x30UC	150x75PFC	254x146x31UB	406x178x74UB
	Extra Plus (E+)	9.55	6.55	152x152x30UC	150x75PFC	254x146x43UB	457x191x74UB
The Cantley (Can)	Standard (S)	8.55	4.55	152x152x23UC	150x75PFC	254x146x37UB	406x178x74UB
	Extra (E)	9.55	4.55	152x152x23UC	150x75PFC	254x146x43UB	457x191x74UB
	Extra Plus (E+)	10.55	5.05	152x152x23UC	200x75PFC	305x165x46UB	457x191x82UB
The Ravenscroft (Ra)	Standard (S)	10.05	4.55	152x152x23UC	200x75PFC	305x165x40UB	457x191x82UB
	Extra (E)	12.05	5.05	152x152x23UC	230x75PFC	406x178x60UB	533x210x82UB
	Extra Plus (E+)	12.55	5.55	152x152x23UC	260x75PFC	406x178x67UB	457x191x89UB
The Dinscroft (Du)	Standard (S)	8.05	5.55	152x152x23UC	150x75PFC	254x146x31UB	406x178x74UB
	Extra (E)	9.05	6.05	152x152x30UC	150x75PFC	254x146x37UB	406x178x74UB
	Extra Plus (E+)	10.05	6.55	152x152x30UC	200x75PFC	305x165x40UB	457x191x82UB
The Hickleton (Hi)	Standard (S)	9.05	6.05	152x152x30UC	150x75PFC	254x146x37UB	406x178x74UB
	Extra (E)	10.05	6.55	152x152x30UC	200x75PFC	305x165x40UB	457x191x82UB
	Extra Plus (E+)	12.05	6.55	152x152x30UC	230x75PFC	406x178x60UB	533x210x82UB
The Melton (Me)	Standard (S)	12.05	4.55	152x152x23UC	230x75PFC	406x178x60UB	533x210x82UB
	Extra (E)	13.05	5.05	152x152x23UC	230x90PFC	406x178x67UB	457x191x89UB
	Extra Plus (E+)	13.55	5.55	152x152x23UC	230x90PFC	406x178x74UB	457x191x89UB
The Cadeby (Cad)	Standard (S)	9.55	5.05	152x152x23UC	150x75PFC	254x146x43UB	457x191x74UB
	Extra (E)	11.05	5.55	152x152x23UC	200x75PFC	356x171x51UB	457x191x82UB
	Extra Plus (E+)	12.55	6.05	152x152x30UC	260x75PFC	406x178x67UB	457x191x89UB
The Loversall (Lo)	Standard (S)	8.55	6.05	152x152x30UC	150x75PFC	254x146x37UB	406x178x74UB
	Extra (E)	10.05	6.55	152x152x30UC	200x75PFC	305x165x40UB	457x191x82UB
	Extra Plus (E+)	12.05	6.55	152x152x30UC	230x75PFC	406x178x60UB	533x210x82UB
The Hatfield (Ha)	Standard (S)	10.05	6.55	152x152x30UC	200x75PFC	305x165x40UB	457x191x82UB
	Extra (E)	11.05	6.55	152x152x30UC	200x75PFC	356x171x51UB	457x191x82UB
	Extra Plus (E+)	12.05	6.55	152x152x30UC	230x75PFC	406x178x60UB	533x210x82UB
The Wheatley (Wh)	Standard (S)	10.05	6.05	152x152x30UC	200x75PFC	305x165x40UB	457x191x82UB
	Extra (E)	12.05	6.55	152x152x30UC	230x75PFC	406x178x60UB	533x210x82UB
	Extra Plus (E+)	13.55	6.55	152x152x30UC	230x90PFC	406x178x74UB	457x191x89UB

STRUCTURAL CALCULATION



Project Ref	P22-0006.128				Project Title	Generic Mobile Home Lifting											
Doc Ref	P22-0006-HSC-Ca-S-128				Doc Title	Generic Mobile Home Lifting Assessment											
Version No	01	Date	Aug 23	Calcs By:	RJS	Date	Aug 23	Check By:	RS	Date	Aug 23	Appr'd By:	RJS	Sheet No	33	Sheet Version	01

Case B - Flat Roof (With Canopy) - 2.3m Cassette Width

Building Name	Version	Overall Width (m)	Overall Depth (m)	Needle Beam (2No)	Edge Beam	Sec Beam	Prim Beam
The Bawtry (Ba)	Standard (S)	7.05	5.05	152x152x23UC	150x75PFC	203x133x30UB	406x178x67UB
	Extra (E)	8.05	6.05	152x152x30UC	150x75PFC	254x146x31UB	406x178x74UB
	Extra Plus (E+)	9.55	6.55	152x152x37UC	150x75PFC	254x146x43UB	457x191x74UB
The Cantley (Can)	Standard (S)	8.55	4.55	152x152x23UC	150x75PFC	254x146x37UB	406x178x74UB
	Extra (E)	9.55	4.55	152x152x23UC	150x75PFC	254x146x43UB	457x191x74UB
	Extra Plus (E+)	10.55	5.05	152x152x23UC	200x75PFC	305x165x46UB	457x191x82UB
The Ravenscroft (Ra)	Standard (S)	10.05	4.55	152x152x23UC	180x75PFC	305x165x40UB	457x191x82UB
	Extra (E)	12.05	5.05	152x152x23UC	200x90PFC	406x178x60UB	533x210x82UB
	Extra Plus (E+)	12.55	5.55	152x152x30UC	230x90PFC	406x178x67UB	457x191x89UB
The Dinscroft (Du)	Standard (S)	8.05	5.55	152x152x30UC	150x75PFC	254x146x31UB	406x178x74UB
	Extra (E)	9.05	6.05	152x152x30UC	150x75PFC	254x146x37UB	406x178x74UB
	Extra Plus (E+)	10.05	6.55	152x152x37UC	180x75PFC	305x165x40UB	457x191x82UB
The Hickleton (Hi)	Standard (S)	9.05	6.05	152x152x30UC	150x75PFC	254x146x37UB	406x178x74UB
	Extra (E)	10.05	6.55	152x152x37UC	180x75PFC	305x165x40UB	457x191x82UB
	Extra Plus (E+)	12.05	6.55	152x152x37UC	200x90PFC	406x178x60UB	533x210x82UB
The Melton (Me)	Standard (S)	12.05	4.55	152x152x23UC	200x90PFC	406x178x60UB	533x210x82UB
	Extra (E)	13.05	5.05	152x152x23UC	230x90PFC	406x178x67UB	457x191x89UB
	Extra Plus (E+)	13.55	5.55	152x152x30UC	230x90PFC	406x178x74UB	457x191x89UB
The Cadeby (Cad)	Standard (S)	9.55	5.05	152x152x23UC	150x75PFC	254x146x43UB	457x191x74UB
	Extra (E)	11.05	5.55	152x152x30UC	200x75PFC	356x171x51UB	457x191x82UB
	Extra Plus (E+)	12.55	6.05	152x152x30UC	230x90PFC	406x178x67UB	457x191x89UB
The Loversall (Lo)	Standard (S)	8.55	6.05	152x152x30UC	150x75PFC	254x146x37UB	406x178x74UB
	Extra (E)	10.05	6.55	152x152x37UC	180x75PFC	305x165x40UB	457x191x82UB
	Extra Plus (E+)	12.05	6.55	152x152x37UC	200x90PFC	406x178x60UB	533x210x82UB
The Hatfield (Ha)	Standard (S)	10.05	6.55	152x152x37UC	180x75PFC	305x165x40UB	457x191x82UB
	Extra (E)	11.05	6.55	152x152x37UC	200x75PFC	356x171x51UB	457x191x82UB
	Extra Plus (E+)	12.05	6.55	152x152x37UC	200x90PFC	406x178x60UB	533x210x82UB
The Wheatley (Wh)	Standard (S)	10.05	6.05	152x152x30UC	180x75PFC	305x165x40UB	457x191x82UB
	Extra (E)	12.05	6.55	152x152x37UC	200x90PFC	406x178x60UB	533x210x82UB
	Extra Plus (E+)	13.55	6.55	152x152x37UC	230x90PFC	406x178x74UB	457x191x89UB

STRUCTURAL CALCULATION



Hibbert Smith Consulting Ltd – Structural & Civil Engineers
T: 07949 171 787 W: www.HibbertSmith.com

Project Ref	P22-0006.128				Project Title	Generic Mobile Home Lifting											
Doc Ref	P22-0006-HSC-Ca-S-128				Doc Title	Generic Mobile Home Lifting Assessment											
Version No	01	Date	Aug 23	Calcs By:	RJS	Date	Aug 23	Check By:	RS	Date	Aug 23	Appr'd By:	RJS	Sheet No	34	Sheet Version	01

Case C - Pitched Roof - 1.9m Cassette Width

Building Name	Version	Overall Width (m)	Overall Depth (m)	Needle Beam (2No.)	Edge Beam	Sec Beam	Prim Beam
The Bawtry (Ba)	Standard (S)	7.05	5.05	152x89x16UB	150x75PFC	203x133x30UB	406x178x60UB
	Extra (E)	8.05	6.05	152x152x23UC	150x75PFC	254x146x31UB	406x178x67UB
	Extra Plus (E+)	9.55	6.55	152x152x23UC	150x75PFC	254x146x43UB	457x191x67UB
The Cantley (Can)	Standard (S)	8.55	4.55	152x89x16UB	150x75PFC	254x146x37UB	406x178x67UB
	Extra (E)	9.55	4.55	152x89x16UB	150x75PFC	254x146x43UB	457x191x67UB
	Extra Plus (E+)	10.55	5.05	152x89x16UB	200x75PFC	305x165x46UB	406x178x74UB
The Ravenscroft (Ra)	Standard (S)	10.05	4.55	152x89x16UB	200x75PFC	305x165x40UB	406x178x74UB
	Extra (E)	12.05	5.05	152x89x16UB	230x75PFC	406x178x60UB	457x191x82UB
	Extra Plus (E+)	12.55	5.55	152x89x16UB	230x75PFC	406x178x67UB	457x191x82UB
The Dinscroft (Du)	Standard (S)	8.05	5.55	152x89x16UB	150x75PFC	254x146x31UB	406x178x67UB
	Extra (E)	9.05	6.05	152x152x23UC	150x75PFC	254x146x37UB	406x178x67UB
	Extra Plus (E+)	10.05	6.55	152x152x23UC	200x75PFC	305x165x40UB	406x178x74UB
The Hickleton (Hi)	Standard (S)	9.05	6.05	152x152x23UC	150x75PFC	254x146x37UB	406x178x67UB
	Extra (E)	10.05	6.55	152x152x23UC	200x75PFC	305x165x40UB	406x178x74UB
	Extra Plus (E+)	12.05	6.55	152x152x23UC	230x75PFC	406x178x60UB	457x191x82UB
The Melton (Me)	Standard (S)	12.05	4.55	152x89x16UB	230x75PFC	406x178x60UB	457x191x82UB
	Extra (E)	13.05	5.05	152x89x16UB	260x75PFC	406x178x67UB	457x191x82UB
	Extra Plus (E+)	13.55	5.55	152x89x16UB	260x75PFC	406x178x74UB	457x191x82UB
The Cadeby (Cad)	Standard (S)	9.55	5.05	152x89x16UB	150x75PFC	254x146x43UB	457x191x67UB
	Extra (E)	11.05	5.55	152x89x16UB	200x75PFC	356x171x51UB	406x178x74UB
	Extra Plus (E+)	12.55	6.05	152x152x23UC	230x75PFC	406x178x67UB	457x191x82UB
The Loversall (Lo)	Standard (S)	8.55	6.05	152x152x23UC	150x75PFC	254x146x37UB	406x178x67UB
	Extra (E)	10.05	6.55	152x152x23UC	200x75PFC	305x165x40UB	406x178x74UB
	Extra Plus (E+)	12.05	6.55	152x152x23UC	230x75PFC	406x178x60UB	457x191x82UB
The Hatfield (Ha)	Standard (S)	10.05	6.55	152x152x23UC	200x75PFC	305x165x40UB	406x178x74UB
	Extra (E)	11.05	6.55	152x152x23UC	200x75PFC	356x171x51UB	406x178x74UB
	Extra Plus (E+)	12.05	6.55	152x152x23UC	230x75PFC	406x178x60UB	457x191x82UB
The Wheatley (Wh)	Standard (S)	10.05	6.05	152x152x23UC	200x75PFC	305x165x40UB	406x178x74UB
	Extra (E)	12.05	6.55	152x152x23UC	230x75PFC	406x178x60UB	457x191x82UB
	Extra Plus (E+)	13.55	6.55	152x152x23UC	260x75PFC	406x178x74UB	457x191x82UB

STRUCTURAL CALCULATION



Hibbert Smith Consulting Ltd – Structural & Civil Engineers
T: 07949 171 787 W: www.HibbertSmith.com

Project Ref	P22-0006.128				Project Title	Generic Mobile Home Lifting											
Doc Ref	P22-0006-HSC-Ca-S-128				Doc Title	Generic Mobile Home Lifting Assessment											
Version No	01	Date	Aug 23	Calcs By:	RJS	Date	Aug 23	Check By:	RS	Date	Aug 23	Apprd By:	RJS	Sheet No	35	Sheet Version	01

Case C - Pitched Roof - 2.3m Cassette Width

Building Name	Version	Overall Width (m)	Overall Depth (m)	Needle Beam (2No.)	Edge Beam	Sec Beam	Prim Beam
The Bawtry (Ba)	Standard (S)	7.05	5.05	152x89x16UB	150x75PFC	203x133x30UB	406x178x60UB
	Extra (E)	8.05	6.05	152x152x23UC	150x75PFC	254x146x31UB	406x178x67UB
	Extra Plus (E+)	9.55	6.55	152x152x30UC	150x75PFC	254x146x43UB	457x191x67UB
The Cantley (Can)	Standard (S)	8.55	4.55	152x89x16UB	150x75PFC	254x146x37UB	406x178x67UB
	Extra (E)	9.55	4.55	152x89x16UB	150x75PFC	254x146x43UB	457x191x67UB
	Extra Plus (E+)	10.55	5.05	152x89x16UB	200x75PFC	305x165x46UB	406x178x74UB
The Ravenscroft (Ra)	Standard (S)	10.05	4.55	152x89x16UB	180x75PFC	305x165x40UB	406x178x74UB
	Extra (E)	12.05	5.05	152x89x16UB	200x90PFC	406x178x60UB	457x191x82UB
	Extra Plus (E+)	12.55	5.55	152x152x23UC	200x90PFC	406x178x67UB	457x191x82UB
The Dinscroft (Du)	Standard (S)	8.05	5.55	152x152x23UC	150x75PFC	254x146x31UB	406x178x67UB
	Extra (E)	9.05	6.05	152x152x23UC	150x75PFC	254x146x37UB	406x178x67UB
	Extra Plus (E+)	10.05	6.55	152x152x30UC	180x75PFC	305x165x40UB	406x178x74UB
The Hickleton (Hi)	Standard (S)	9.05	6.05	152x152x23UC	150x75PFC	254x146x37UB	406x178x67UB
	Extra (E)	10.05	6.55	152x152x30UC	180x75PFC	305x165x40UB	406x178x74UB
	Extra Plus (E+)	12.05	6.55	152x152x30UC	200x90PFC	406x178x60UB	457x191x82UB
The Melton (Me)	Standard (S)	12.05	4.55	152x89x16UB	200x90PFC	406x178x60UB	457x191x82UB
	Extra (E)	13.05	5.05	152x89x16UB	200x90PFC	406x178x67UB	457x191x82UB
	Extra Plus (E+)	13.55	5.55	152x152x23UC	200x90PFC	406x178x74UB	457x191x82UB
The Cadeby (Cad)	Standard (S)	9.55	5.05	152x89x16UB	150x75PFC	254x146x43UB	457x191x67UB
	Extra (E)	11.05	5.55	152x152x23UC	200x75PFC	356x171x51UB	406x178x74UB
	Extra Plus (E+)	12.55	6.05	152x152x23UC	200x90PFC	406x178x67UB	457x191x82UB
The Loversall (Lo)	Standard (S)	8.55	6.05	152x152x23UC	150x75PFC	254x146x37UB	406x178x67UB
	Extra (E)	10.05	6.55	152x152x30UC	180x75PFC	305x165x40UB	406x178x74UB
	Extra Plus (E+)	12.05	6.55	152x152x30UC	200x90PFC	406x178x60UB	457x191x82UB
The Hatfield (Ha)	Standard (S)	10.05	6.55	152x152x30UC	180x75PFC	305x165x40UB	406x178x74UB
	Extra (E)	11.05	6.55	152x152x30UC	200x75PFC	356x171x51UB	406x178x74UB
	Extra Plus (E+)	12.05	6.55	152x152x30UC	200x90PFC	406x178x60UB	457x191x82UB
The Wheatley (Wh)	Standard (S)	10.05	6.05	152x152x23UC	180x75PFC	305x165x40UB	406x178x74UB
	Extra (E)	12.05	6.55	152x152x30UC	200x90PFC	406x178x60UB	457x191x82UB
	Extra Plus (E+)	13.55	6.55	152x152x30UC	200x90PFC	406x178x74UB	457x191x82UB

STRUCTURAL CALCULATION



Project Ref		P22-0006.128				Project Title		Generic Mobile Home Lifting								
Doc Ref		P22-0006-HSC-Ca-S-128				Doc Title		Generic Mobile Home Lifting Assessment								
Version No	Date	Aug 23	Calcs By:	RJS	Date	Aug 23	Check By:	RS	Date	Aug 23	Appr'd By:	RJS	Sheet No	36	Sheet Version	01

Structural Calculations

NeedeBeams (Selected Cases)

BEAM & BEAM-PORION (MEMBER)

A-01: Span 1

Span 1 Between 0.500 and 2.800 m, in Load Case 1

Member Loading and Member Forces

Loading Combination : 1 UT + 1.35 D1 + 1.5 L1

D1 UDLW -000.317 (kN/m)
 L1 PY -008.130 0.500 (kN,m)
 L1 PY -002.620 2.800 (kN,m)
 L1 PY -008.130 5.100 (kN,m)
 L1 PDLY -002.990 0.500 5.100 (kN,m,m)

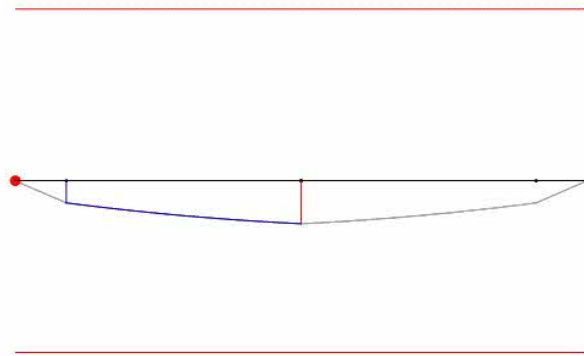

Member Forces in Load Case 1 and Maximum Deflection from Load Case 2

Span No.	Axial Force (kN)	Shear Force (kN)		Bending Moment (kNm)		Maximum Moment (kNm)	Maximum Deflection (mm @ m)
		End 1	End 2	Node 1	Node 2		
1	0.00C	17.60	-17.60	0.00	0.00	16.98 @ 2.800	9.51 @ 2.800

Classification and Effective Area (EN 1993: 2006)

Section (15.95 kg/m) 2 No. 152x89 UB 16 [Grade 43]
 Class = $F_n(b/T, d/t, f_y, N, M_y, M_z)$ 5.76, 27.07, 275, 0, 16.97, 0 (Axial: Non-Slender) Class 1

Auto Design Load Cases 1

Shear Capacity Check

$V_{y,Ed}/V_{pl,y,Rd}$ 17.386 / 259.658 = 0.067 OK

Moment Capacity Check M.c.y.Rd

$V_{y,Ed}/V_{pl,y,Rd}$ 1.964 / 259.658 = 0.008 Low Shear
 $M_{c,y,Rd} = f_y \cdot W_{pl,y} / \gamma_{M0}$ 275 x 246.6/1 67.815 kN.m
 $M_{y,Ed}/M_{c,y,Rd}$ 16.974 / 67.815 = 0.250 OK

Equivalent Uniform Moment Factor C1

$C_1 = f_n(M_1, M_2, -y)$ 8.7, 17.0, 0.516 1.288 Not Loaded

Lateral Buckling Check M.b.Rd

$L_e = 1.0 L$ 1 x 2.3 = 2.3 m
 $M_{cr} = F_n(C_1, L_e, I_z, I_t, I_w, E)$ 1.288, 2.300, 181.2, 7.121, 0.009376, 210000 105.393 kN.m
 $\lambda_{LT} = \sqrt{W \cdot f_y / M_{cr}}$ $\sqrt{246.6 \times 275 / 105.393}$ 0.802
 $CLT = F_n(\lambda_{LT}, \Phi_{LT}, \beta, \lambda_{LT0})$ 0.802, 0.810, 0.750, 0.400 0.816 Curve b
 $CLT.mod = F_n(CL_T, \lambda_{LT}, k_c, f)$ 0.816, 0.802, 0.881, 0.940 0.868 6.3.2.3
 $M_{b,Rd} = C \cdot W_{pl,y} \cdot f_y \leq M_{c,y,Rd}$ 0.868 x 246.6 x 275 \leq 67.815 = 58.836 kN.m
 $M_{y,Ed}/M_{b,Rd}$ 16.974 / 58.836 0.288 OK

Deflection Check - Load Case 2

In-span $\delta \leq \text{Span}/360$ 9.51 \leq 5600 / 360 9.51 mm OK

STRUCTURAL CALCULATION



Project Ref	P22-0006.128				Project Title	Generic Mobile Home Lifting											
Doc Ref	P22-0006-HSC-Ca-S-128				Doc Title	Generic Mobile Home Lifting Assessment											
Version No	01	Date	Aug 23	Calcs By:	RJS	Date	Aug 23	Check By:	RS	Date	Aug 23	Appr'd By:	RJS	Sheet No	37	Sheet Version	01

BEAM & BEAM-PORTION (MEMBER)

A-02: Span 1

Span 1 Between 0.500 and 3.050 m, in Load Case 1

Member Loading and Member Forces

Loading Combination : 1 UT + 1.35 D1 + 1.5 L1

D1 UDLW -000.317 (kN/m)
 L1 PY -008.650 0.500 (kN,m)
 L1 PY -002.910 3.050 (kN,m)
 L1 PY -008.650 5.600 (kN,m)
 L1 PDLY -003.315 0.500 5.600 (kN,m,m)

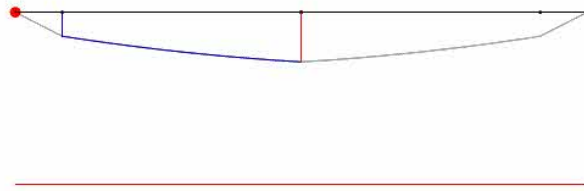

Member Forces in Load Case 1 and Maximum Deflection from Load Case 2

Span No.	Axial Force (kN)	Shear Force (kN)		Bending Moment (kNm)		Maximum Moment (kNm)	Maximum Deflection (mm @ m)
		End 1	End 2	Node 1	Node 2		
1	0.00C	18.95	-18.95	0.00	0.00	19.55 @ 3.050	12.84 @ 3.050

Classification and Effective Area (EN 1993: 2006)

Section (15.95 kg/m) 2 No. 152x89 UB 16 [Grade 43]
 Class = $F_n(b/T, d/t, f_y, N, M_y, M_z)$ 5.76, 27.07, 275, 0, 19.55, 0 (Axial: Non-Slender) Class 1

Auto Design Load Cases 1

Shear Capacity Check

$V_{y,Ed}/V_{pl,y,Rd}$ 18.734 / 259.658 = 0.072 OK

Moment Capacity Check M.c.y.Rd

$V_{y,Ed}/V_{pl,y,Rd}$ 2.183 / 259.658 = 0.008 Low Shear

$M_{c,y,Rd} = f_y \cdot W_{pl,y} / \gamma_{M0}$ 275 x 246.6/1 67.815 kN.m

$M_{y,Ed}/M_{c,y,Rd}$ 19.546 / 67.815 = 0.288 OK

Equivalent Uniform Moment Factor C1

$C_1 = f_n(M_1, M_2, -y)$ 9.4, 19.5, 0.482 1.313 Not Loaded

Lateral Buckling Check M.b.Rd

$L_e = 1.0 L$ 1 x 2.55 = 2.55 m

$M_{cr} = F_n(C_1, L_e, I_z, I_t, I_w, E)$ 1.313, 2.550, 181.2, 7.121, 0.009376, 210000 93.318 kN.m

$\lambda_{LT} = \sqrt{W \cdot f_y / M_{cr}}$ $\sqrt{246.6 \times 275 / 93.318}$ 0.852

$C_{LT} = F_n(\lambda_{LT}, \Phi_{LT}, \beta, \lambda_{LT0})$ 0.852, 0.849, 0.750, 0.400 0.788 Curve b

$C_{LT,mod} = F_n(C_{LT}, \lambda_{LT}, k_c, f)$ 0.788, 0.852, 0.873, 0.937 0.841 6.3.2.3

$M_{b,Rd} = C \cdot W_{pl,y} \cdot f_y \leq M_{c,y,Rd}$ 0.841 x 246.6 x 275 \leq 67.815 = 57.030 kN.m

$M_{y,Ed}/M_{b,Rd}$ 19.546 / 57.03 0.343 OK

Deflection Check - Load Case 2

In-span $\delta \leq \text{Span}/360$ 12.84 \leq 6100 / 360 12.84 mm OK

STRUCTURAL CALCULATION



Project Ref	P22-0006.128				Project Title	Generic Mobile Home Lifting											
Doc Ref	P22-0006-HSC-Ca-S-128				Doc Title	Generic Mobile Home Lifting Assessment											
Version No	01	Date	Aug 23	Calcs By:	RJS	Date	Aug 23	Check By:	RS	Date	Aug 23	Appr'd By:	RJS	Sheet No	38	Sheet Version	01

BEAM & BEAM-PORTION (MEMBER)

A-03: Span 1

Span 1 Between 0.500 and 3.300 m, in Load Case 1

Member Loading and Member Forces

Loading Combination : 1 UT + 1.35 D1 + 1.5 L1

D1 UDLW -000.317 (kN/m)
 L1 PY -009.180 0.500 (kN,m)
 L1 PY -003.190 3.300 (kN,m)
 L1 PY -009.180 6.100 (kN,m)
 L1 PDLY -003.640 0.500 6.100 (kN,m,m)

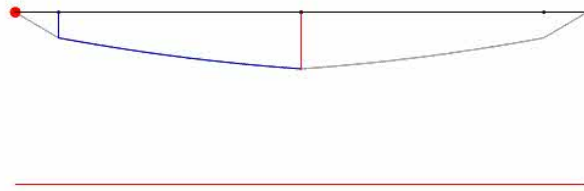

Member Forces in Load Case 1 and Maximum Deflection from Load Case 2

Span No.	Axial Force (kN)	Shear Force (kN)		Bending Moment (kNm)		Maximum Moment (kNm)	Maximum Deflection (mm @ m)
		End 1	End 2	Node 1	Node 2		
1	0.00C	20.30	-20.30	0.00	0.00	22.30 @ 3.300	16.97 @ 3.300

Classification and Effective Area (EN 1993: 2006)

Section (15.95 kg/m) 2 No. 152x89 UB 16 [Grade 43]
 Class = $F_n(b/T, d/t, f_y, N, M_y, M_z)$ 5.76, 27.07, 275, 0, 22.29, 0 (Axial: Non-Slender) Class 1
 Auto Design Load Cases 1

Shear Capacity Check

$V_{y,Ed}/V_{pl,y,Rd}$ 20.09 / 259.658 = 0.077 OK

Moment Capacity Check M.c.y.Rd

$V_{y,Ed}/V_{pl,y,Rd}$ 2.393 / 259.658 = 0.009 Low Shear
 $M_{c,y,Rd} = f_y \cdot W_{pl,y} / \gamma_{M0}$ 275 x 246.6/1 = 67.815 kN.m
 $M_{y,Ed}/M_{c,y,Rd}$ 22.292 / 67.815 = 0.329 OK

Equivalent Uniform Moment Factor C1

$C_1 = f_n(M_1, M_2, -y)$ 10.1, 22.3, 0.453 1.336 Not Loaded

Lateral Buckling Check M.b.Rd

$L_e = 1.0 L$ 1 x 2.8 = 2.8 m
 $M_{cr} = F_n(C_1, L_e, I_z, I_t, I_w, E)$ 1.336, 2.800, 181.2, 7.121, 0.009376, 210000 = 83.867 kN.m
 $\lambda_{LT} = \sqrt{W \cdot f_y / M_{cr}}$ $\sqrt{246.6 \times 275 / 83.867}$ = 0.899
 $CLT = F_n(\lambda_{LT}, \Phi_{LT}, \beta, \lambda_{LT0})$ 0.899, 0.888, 0.750, 0.400 = 0.760 Curve b
 $CLT.mod = F_n(CL_T, \lambda_{LT}, k_c, f)$ 0.760, 0.899, 0.865, 0.934 = 0.814 6.3.2.3
 $M_{b,Rd} = C \cdot W_{pl,y} \cdot f_y \leq M_{c,y,Rd}$ 0.814 x 246.6 x 275 \leq 67.815 = 55.217 kN.m
 $M_{y,Ed}/M_{b,Rd}$ 22.292 / 55.217 = 0.404 OK

Deflection Check - Load Case 2

In-span $\delta \leq \text{Span}/360$ 16.97 \leq 6600 / 360 16.97 mm OK

STRUCTURAL CALCULATION



Project Ref	P22-0006.128				Project Title	Generic Mobile Home Lifting											
Doc Ref	P22-0006-HSC-Ca-S-128				Doc Title	Generic Mobile Home Lifting Assessment											
Version No	01	Date	Aug 23	Calcs By:	RJS	Date	Aug 23	Check By:	RS	Date	Aug 23	Appr'd By:	RJS	Sheet No	39	Sheet Version	01

BEAM & BEAM-PORION (MEMBER)

A-04: Span 1

Span 1 Between 0.500 and 3.550 m, in Load Case 1

Member Loading and Member Forces

Loading Combination : 1 UT + 1.35 D1 + 1.5 L1

D1 UDLW -000.456 (kN/m)
 L1 PY -009.700 0.500 (kN,m)
 L1 PY -003.480 3.550 (kN,m)
 L1 PY -009.700 6.600 (kN,m)
 L1 PDLY -003.965 0.500 6.600 (kN,m,m)

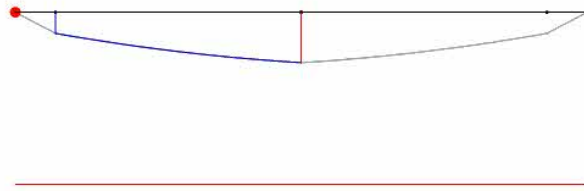

Member Forces in Load Case 1 and Maximum Deflection from Load Case 2

Span No.	Axial Force (kN)	Shear Force (kN)		Bending Moment (kNm)		Maximum Moment (kNm)	Maximum Deflection (mm @ m)
		End 1	End 2	Node 1	Node 2		
1	0.00C	22.32	-22.32	0.00	0.00	26.44 @ 3.550	14.71 @ 3.550

Classification and Effective Area (EN 1993: 2006)

Section (22.95 kg/m) 2 No. 152x152 UC 23 [Grade 43]
 Class = $F_n(b/t, d/t, f_y, N, M_y, M_z)$ 11.19, 21.31, 275, 0, 26.44, 0 (Axial: Non-Slender) Class 3

Effective Properties Area=58.48(29.24) cm², $W_{pl,y}=358.78(182)$ cm³, $W_{pl,z}=152.35(80.2)$ cm³
 Auto Design Load Cases 1

Shear Capacity Check

$V_{y,Ed}/V_{pl,y,Rd}$ 22.011 / 316.552 = 0.070 OK

Moment Capacity Check M.c.y.Rd

$V_{y,Ed}/V_{pl,y,Rd}$ 2.612 / 316.552 = 0.008 Low Shear
 $M_{c,y,Rd} = f_y \cdot W_{el,y} / \gamma_{M0}$ 275 x 328.26/1 = 90.272 kN.m
 $M_{y,Ed}/M_{c,y,Rd}$ 26.44 / 90.272 = 0.293 OK

Equivalent Uniform Moment Factor C1

$C_1 = f_n(M_1, M_2, -y)$ 11.1, 26.4, 0.419 1.362 Not Loaded

Lateral Buckling Check M.b.Rd

$L_e = 1.0 L$ 1 x 3.05 = 3.05 m
 $M_{cr} = F_n(C_1, L_e, I_z, I_t, I_w, E)$ 1.362, 3.050, 801.6, 9.27, 0.04235, 210000 236.864 kN.m
 $\lambda_{LT} = \sqrt{W_{pl,y}/M_{cr}}$ $\sqrt{358.8 \times 275 / 236.864}$ 0.617
 $C_{LT} = F_n(\lambda_{LT}, \Phi_{LT}, \beta, \lambda_{LT0})$ 0.617, 0.680, 0.750, 0.400 0.909 Curve b
 $C_{LT,mod} = F_n(C_{LT}, \lambda_{LT}, k_c, f)$ 0.909, 0.617, 0.857, 0.933 0.974 6.3.2.3
 $M_{b,Rd} = C W_{pl,y} \cdot f_y \leq M_{c,y,Rd}$ 0.974 x 358.8 x 275 \leq 90.272 = 87.957 kN.m
 $M_{y,Ed}/M_{b,Rd}$ 26.44 / 87.957 0.301 OK

Deflection Check - Load Case 2

In-span $\delta \leq$ Span/360 14.71 \leq 7100 / 360 14.71 mm OK

STRUCTURAL CALCULATION



Hibbert Smith Consulting Ltd – Structural & Civil Engineers
T: 07949 171 787 W: www.HibbertSmith.com

Project Ref	P22-0006.128				Project Title	Generic Mobile Home Lifting											
Doc Ref	P22-0006-HSC-Ca-S-128				Doc Title	Generic Mobile Home Lifting Assessment											
Version No	01	Date	Aug 23	Calcs By:	RJS	Date	Aug 23	Check By:	RS	Date	Aug 23	Apprd By:	RJS	Sheet No	40	Sheet Version	01

BEAM & BEAM-PORION (MEMBER)

A-05: Span 1

Span 1 Between 0.500 and 3.800 m, in Load Case 1

Member Loading and Member Forces

Loading Combination : 1 UT + 1.35 D1 + 1.5 L1

D1 UDLW -000.456 (kN/m)
L1 PY -010.220 0.500 (kN,m)
L1 PY -003.760 3.800 (kN,m)
L1 PY -010.220 7.100 (kN,m)
L1 PDLY -004.290 0.500 7.100 (kN,m,m)

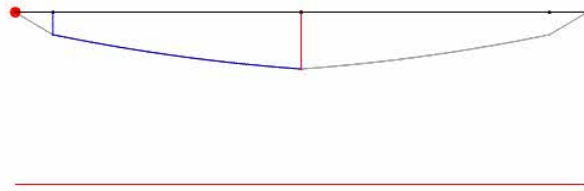

Member Forces in Load Case 1 and Maximum Deflection from Load Case 2

Span No.	Axial Force (kN)	Shear Force (kN)		Bending Moment (kNm)		Maximum Moment (kNm)	Maximum Deflection (mm @ m)
		End 1	End 2	Node 1	Node 2		
1	0.00C	23.71	-23.71	0.00	0.00	29.74 @ 3.800	18.79 @ 3.800

Classification and Effective Area (EN 1993: 2006)

Section (22.95 kg/m) 2 No. 152x152 UC 23 [Grade 43]
Class = $F_n(b/T, d/t, f_y, N, M_y, M_z)$ 11.19, 21.31, 275, 0, 29.74, 0 (Axial: Non-Slender) Class 3

Effective Properties Area=58.48(29.24) cm², $W_{pl,y}=358.78(182)$ cm³, $W_{pl,z}=152.35(80.2)$ cm³
Auto Design Load Cases 1

Shear Capacity Check

$V_{y,Ed}/V_{pl,y,Rd}$ 23.398 / 316.552 = 0.074 OK

Moment Capacity Check M.c.y.Rd

$V_{y,Ed}/V_{pl,y,Rd}$ 2.82 / 316.552 = 0.009 Low Shear
 $M_{c,y,Rd} = f_y \cdot W_{el,y} / \gamma_{M0}$ 275 x 328.26/1 = 90.272 kN.m
 $M_{y,Ed}/M_{c,y,Rd}$ 29.738 / 90.272 = 0.329 OK

Equivalent Uniform Moment Factor C1

$C_1 = f_n(M_1, M_2, -y)$ 11.8, 29.7, 0.396 1.381 Not Loaded

Lateral Buckling Check M.b.Rd

$L_e = 1.0 L$ 1 x 3.3 = 3.3 m
 $M_{cr} = F_n(C_1, L_e, I_z, I_t, I_w, E)$ 1.381, 3.300, 801.6, 9.27, 0.04235, 210000 212.710 kN.m
 $\lambda_{LT} = \sqrt{W_{pl,y}/M_{cr}}$ $\sqrt{358.8 \times 275 / 212.71}$ 0.651
 $C_{LT} = F_n(\lambda_{LT}, \Phi_{LT}, \beta, \lambda_{LT0})$ 0.651, 0.702, 0.750, 0.400 0.893 Curve b
 $C_{LT,mod} = F_n(C_{LT}, \lambda_{LT}, k_c, f)$ 0.893, 0.651, 0.851, 0.929 0.962 6.3.2.3
 $M_{b,Rd} = C W_{pl,y} \cdot f_y \leq M_{c,y,Rd}$ 0.962 x 358.8 x 275 \leq 90.272 = 86.825 kN.m
 $M_{y,Ed}/M_{b,Rd}$ 29.738 / 86.825 0.343 OK

Deflection Check - Load Case 2

In-span $\delta \leq \text{Span}/360$ 18.79 \leq 7600 / 360 18.79 mm OK

STRUCTURAL CALCULATION



Project Ref		P22-0006.128				Project Title		Generic Mobile Home Lifting								
Doc Ref		P22-0006-HSC-Ca-S-128				Doc Title		Generic Mobile Home Lifting Assessment								
Version No	Date	Aug 23	Calcs By:	RJS	Date	Aug 23	Check By:	RS	Date	Aug 23	Appr'd By:	RJS	Sheet No	41	Sheet Version	01

BEAM & BEAM-PORTION (MEMBER)

B-01: Span 1

Span 1 Between 1.200 and 3.500 m, in Load Case 1

Member Loading and Member Forces

Loading Combination : 1 UT + 1.35 D1 + 1.5 L1

D1 UDLW -000.456 (kN/m)
 L1 PY -009.200 1.200 (kN,m)
 L1 PY -002.620 3.500 (kN,m)
 L1 PY -008.130 5.800 (kN,m)
 L1 PDLY -002.990 1.200 5.800 (kN,m,m)



Member Forces in Load Case 1 and Maximum Deflection from Load Case 2

Span No.	Axial Force (kN)	Shear Force (kN)		Bending Moment (kNm)		Maximum Moment (kNm)	Maximum Deflection (mm @ m)
		End 1	End 2	Node 1	Node 2		
1	0.00C	17.82	-20.47	0.00	0.00	24.32 @ 3.290	11.71 @ 3.080

Classification and Effective Area (EN 1993: 2006)

Section (22.95 kg/m) 2 No. 152x152 UC 23 [Grade 43]
 Class = $F_n(b/T, d/t, f_y, N, M_y, M_z)$ 11.19, 21.31, 275, 0, 24.32, 0 (Axial: Non-Slender) Class 3

Effective Properties Area=58.48(29.24) cm², $W_{pl,y}$ =358.78(182) cm³, $W_{pl,z}$ =152.35(80.2) cm³
 Auto Design Load Cases 1

Shear Capacity Check

$V_{y,Ed}/V_{pl,y,Rd}$ 17.08 / 316.552 = 0.054 OK

Moment Capacity Check M.c.y.Rd

$V_{y,Ed}/V_{pl,y,Rd}$ 0.044 / 316.552 = 0 Low Shear
 $M_{c,y,Rd} = f_y \cdot W_{el,y} / \gamma_{M0}$ 275 x 328.26/1 = 90.272 kN.m
 $M_{y,Ed}/M_{c,y,Rd}$ 24.317 / 90.272 = 0.269 OK

Equivalent Uniform Moment Factor C1

$C_1 = f_n(M_1, M_2, -y)$ 20.9, 24.3, 0.863 1.068 Not Loaded

Lateral Buckling Check M.b.Rd

$L_e = 1.0 L$ 1 x 2.3 = 2.3 m
 $M_{cr} = F_n(C_1, L_e, I_z, I_t, I_w, E)$ 1.068, 2.300, 801.6, 9.27, 0.04235, 210000 293.576 kN.m
 $\lambda_{LT} = \sqrt{W_{pl,y}/M_{cr}}$ $\sqrt{358.8 \times 275 / 293.576}$ 0.555
 $C_{LT} = F_n(\lambda_{LT}, \Phi_{LT}, \beta, \lambda_{LT0})$ 0.555, 0.642, 0.750, 0.400 0.937 Curve b
 $C_{LT,mod} = F_n(C_{LT}, \lambda_{LT}, k_c, f)$ 0.937, 0.555, 0.968, 0.986 0.951 6.3.2.3
 $M_{b,Rd} = C W_{pl,y} \cdot f_y \leq M_{c,y,Rd}$ 0.951 x 358.8 x 275 \leq 90.272 = 85.814 kN.m
 $M_{y,Ed}/M_{b,Rd}$ 24.317 / 85.814 0.283 OK

Deflection Check - Load Case 2

In-span $\delta \leq$ Span/360 11.71 \leq 6300 / 360 11.71 mm OK

STRUCTURAL CALCULATION



Hibbert Smith Consulting Ltd – Structural & Civil Engineers
T: 07949 171 787 W: www.HibbertSmith.com

Project Ref	P22-0006.128				Project Title	Generic Mobile Home Lifting											
Doc Ref	P22-0006-HSC-Ca-S-128				Doc Title	Generic Mobile Home Lifting Assessment											
Version No	01	Date	Aug 23	Calcs By:	RJS	Date	Aug 23	Check By:	RS	Date	Aug 23	Appr'd By:	RJS	Sheet No	42	Sheet Version	01

BEAM & BEAM-PORTION (MEMBER)

B-02: Span 1

Span 1 Between 1.200 and 3.750 m, in Load Case 1

Member Loading and Member Forces

Loading Combination : 1 UT + 1.35 D1 + 1.5 L1

D1 UDLW -000.456 (kN/m)
L1 PY -009.720 1.200 (kN,m)
L1 PY -002.910 3.750 (kN,m)
L1 PY -008.650 6.300 (kN,m)
L1 PDLY -003.315 1.200 6.300 (kN,m,m)



Member Forces in Load Case 1 and Maximum Deflection from Load Case 2

Span No.	Axial Force (kN)	Shear Force (kN)		Bending Moment (kNm)		Maximum Moment (kNm)	Maximum Deflection (mm @ m)
		End 1	End 2	Node 1	Node 2		
1	0.00C	19.24	-21.84	0.00	0.00	27.49 @ 3.627	15.24 @ 3.324

Classification and Effective Area (EN 1993: 2006)

Section (22.95 kg/m)

2 No. 152x152 UC 23 [Grade 43]

Class = Fn(b/T,d/t,f_y,N,M_y,M_z)

11.19, 21.31, 275, 0, 27.49, 0

(Axial: Non-Slender)

Class 3

Effective Properties

Area=58.48(29.24) cm², W_{pl,y}=358.78(182) cm³, W_{pl,z}=152.35(80.2) cm³

Auto Design Load Cases

1

Shear Capacity Check

V_{y,Ed}/V_{pl,y,Rd}

18.503 / 316.552 =

0.058

OK

Moment Capacity Check M_{c,y}.Rd - Fully Restrained Beam

V_{y,Ed}/V_{pl,y,Rd}

0.025 / 316.552 =

0

Low Shear

M_{c,y,Rd} = f_y.W_{el,y}/γ_{M0}

275 x 328.26/1 =

90.272 kN.m

M_{y,Ed}/M_{c,y,Rd}

27.485 / 90.272 =

0.304

OK

Deflection Check - Load Case 2

In-span δ ≤ Span/360

15.24 ≤ 6800 / 360

15.24 mm

OK

STRUCTURAL CALCULATION



Project Ref	P22-0006.128				Project Title	Generic Mobile Home Lifting											
Doc Ref	P22-0006-HSC-Ca-S-128				Doc Title	Generic Mobile Home Lifting Assessment											
Version No	01	Date	Aug 23	Calcs By:	RJS	Date	Aug 23	Check By:	RS	Date	Aug 23	Apprd By:	RJS	Sheet No	43	Sheet Version	01

BEAM & BEAM-PORTION (MEMBER)

B-03: Span 1

Span 1 Between 1.200 and 4.000 m, in Load Case 1

Member Loading and Member Forces

Loading Combination : 1 UT + 1.35 D1 + 1.5 L1

D1 UDLW -000.456 (kN/m)
 L1 PY -010.240 1.200 (kN,m)
 L1 PY -003.190 4.000 (kN,m)
 L1 PY -009.180 6.800 (kN,m)
 L1 PDLY -003.640 1.200 6.800 (kN,m,m)

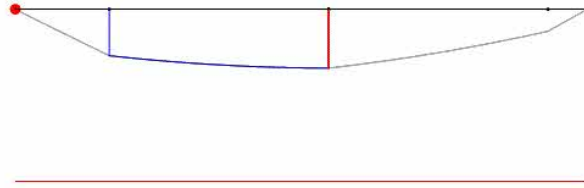

Member Forces in Load Case 1 and Maximum Deflection from Load Case 2

Span No.	Axial Force (kN)	Shear Force (kN)		Bending Moment (kNm)		Maximum Moment (kNm)	Maximum Deflection (mm @ m)
		End 1	End 2	Node 1	Node 2		
1	0.00C	20.66	-23.21	0.00	0.00	30.87 @ 4.000	19.50 @ 3.569

Classification and Effective Area (EN 1993: 2006)

Section (22.95 kg/m) 2 No. 152x152 UC 23 [Grade 43]
 Class = $F_n(b/T, d/t, f_y, N, M_y, M_z)$ 11.19, 21.31, 275, 0, 30.88, 0 (Axial: Non-Slender) Class 3

Effective Properties Area=58.48(29.24) cm², $W_{pl,y}$ =358.78(182) cm³, $W_{pl,z}$ =152.35(80.2) cm³
 Auto Design Load Cases 1

Shear Capacity Check

$V_{y,Ed}/V_{pl,y,Rd}$ 19.918 / 316.552 = 0.063 OK

Moment Capacity Check M.c.y.Rd

$V_{y,Ed}/V_{pl,y,Rd}$ 4.678 / 316.552 = 0.015 Low Shear
 $M_{c,y,Rd} = f_y \cdot W_{el,y} / \gamma_{M0}$ 275 x 328.26/1 = 90.272 kN.m
 $M_{y,Ed}/M_{c,y,Rd}$ 30.87 / 90.272 = 0.342 OK

Equivalent Uniform Moment Factor C1

$C_1 = f_n(M_1, M_2, -y)$ 24.3, 30.9, 0.789 1.109 Not Loaded

Lateral Buckling Check M.b.Rd

$l_e = 1.0 L$ 1 x 2.8 = 2.8 m
 $M_{cr} = F_n(C_1, L_e, I_z, I_t, I_w, E)$ 1.109, 2.800, 801.6, 9.27, 0.04235, 210000 220.589 kN.m
 $\lambda_{LT} = \sqrt{W_{pl,y}/M_{cr}}$ $\sqrt{358.8 \times 275 / 220.589}$ 0.640
 $C_{LT} = F_n(\lambda_{LT}, \Phi_{LT}, \beta, \lambda_{LT0})$ 0.640, 0.694, 0.750, 0.400 0.899 Curve b
 $C_{LT,mod} = F_n(C_{LT}, \lambda_{LT}, k_c, f)$ 0.899, 0.640, 0.950, 0.976 0.921 6.3.2.3
 $M_{b,Rd} = C W_{pl,y} \cdot f_y \leq M_{c,y,Rd}$ 0.921 x 358.8 x 275 \leq 90.272 = 83.120 kN.m
 $M_{y,Ed}/M_{b,Rd}$ 30.877 / 83.12 0.371 OK

Deflection Check - Load Case 2

In-span $\delta \leq \text{Span}/360$ 19.5 \leq 7300 / 360 19.5 mm OK

STRUCTURAL CALCULATION



Project Ref	P22-0006.128				Project Title	Generic Mobile Home Lifting											
Doc Ref	P22-0006-HSC-Ca-S-128				Doc Title	Generic Mobile Home Lifting Assessment											
Version No	01	Date	Aug 23	Calcs By:	RJS	Date	Aug 23	Check By:	RS	Date	Aug 23	Appr'd By:	RJS	Sheet No	44	Sheet Version	01

BEAM & BEAM-PORTION (MEMBER)

B-04: Span 1

Span 1 Between 1.200 and 4.250 m, in Load Case 1

Member Loading and Member Forces

Loading Combination : 1 UT + 1.35 D1 + 1.5 L1

D1 UDLW -000.597 (kN/m)
 L1 PY -010.760 1.200 (kN,m)
 L1 PY -003.480 4.250 (kN,m)
 L1 PY -009.700 7.300 (kN,m)
 L1 PDLY -003.965 1.200 7.300 (kN,m,m)



Member Forces in Load Case 1 and Maximum Deflection from Load Case 2

Span No.	Axial Force (kN)	Shear Force (kN)		Bending Moment (kNm)		Maximum Moment (kNm)	Maximum Deflection (mm @ m)
		End 1	End 2	Node 1	Node 2		
1	0.00C	22.82	-25.33	0.00	0.00	35.92 @ 4.250	17.59 @ 3.813

Classification and Effective Area (EN 1993: 2006)

Section (30.03 kg/m) 2 No. 152x152 UC 30 [Grade 43]
 Class = $F_n(b/t, d/t, f_y, N, M_y, M_z)$ 8.13, 19.02, 275, 0, 35.93, 0

(Axial: Non-Slender) Class 1

Auto Design Load Cases 1

Shear Capacity Check

$V_{y,Ed}/V_{pl,y,Rd}$ 21.848 / 366.908 = 0.060 OK

Moment Capacity Check M.c.y.Rd

$V_{y,Ed}/V_{pl,y,Rd}$ 4.939 / 366.908 = 0.013 Low Shear
 $M_{c,y,Rd} = f_y \cdot W_{pl,y} / \gamma_{M0}$ 275 x 495.4/1 136.235 kN.m
 $M_{y,Ed}/M_{c,y,Rd}$ 35.92 / 136.235 = 0.264 OK

Equivalent Uniform Moment Factor C1

$C_1 = f_n(M_1, M_2, -y)$ 26.8, 35.9, 0.746 1.134 Not Loaded

Lateral Buckling Check M.b.Rd

$L_e = 1.0 L$ 1 x 3.05 = 3.05 m
 $M_{cr} = F_n(C_1, L_e, I_z, I_t, I_w, E)$ 1.134, 3.050, 1123, 21.04, 0.06150, 210000 314.157 kN.m
 $\lambda_{LT} = \sqrt{W \cdot f_y / M_{cr}}$ $\sqrt{495.4 \times 275 / 314.157}$ 0.659
 $C_{LT} = F_n(\lambda_{LT}, \Phi_{LT}, \beta, \lambda_{LT0})$ 0.659, 0.707, 0.750, 0.400 0.890 Curve b
 $C_{LT,mod} = F_n(C_{LT}, \lambda_{LT}, k_c, f)$ 0.890, 0.659, 0.939, 0.971 0.917 6.3.2.3
 $M_{b,Rd} = C \cdot W_{pl,y} \cdot f_y \leq M_{c,y,Rd}$ 0.917 x 495.4 x 275 \leq 136.235 = 124.884 kN.m
 $M_{y,Ed}/M_{b,Rd}$ 35.934 / 124.884 0.288 OK

Deflection Check - Load Case 2

In-span $\delta \leq \text{Span}/360$ 17.59 \leq 7800 / 360 17.59 mm OK

STRUCTURAL CALCULATION



Project Ref	P22-0006.128				Project Title	Generic Mobile Home Lifting											
Doc Ref	P22-0006-HSC-Ca-S-128				Doc Title	Generic Mobile Home Lifting Assessment											
Version No	01	Date	Aug 23	Calcs By:	RJS	Date	Aug 23	Check By:	RS	Date	Aug 23	Appr'd By:	RJS	Sheet No	45	Sheet Version	01

BEAM & BEAM-PORTION (MEMBER)

B-05: Span 1

Span 1 Between 1.200 and 4.500 m, in Load Case 1

Member Loading and Member Forces

Loading Combination : 1 UT + 1.35 D1 + 1.5 L1

D1 UDLW -000.597 (kN/m)
 L1 PY -011.290 1.200 (kN,m)
 L1 PY -003.760 4.500 (kN,m)
 L1 PY -010.220 7.800 (kN,m)
 L1 PDLY -004.290 1.200 7.800 (kN,m,m)

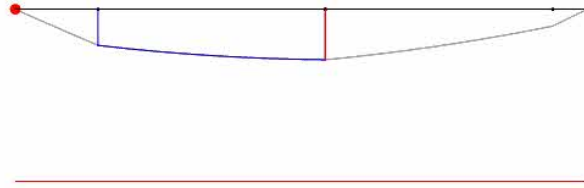

Member Forces in Load Case 1 and Maximum Deflection from Load Case 2

Span No.	Axial Force (kN)	Shear Force (kN)		Bending Moment (kNm)		Maximum Moment (kNm)	Maximum Deflection (mm @ m)
		End 1	End 2	Node 1	Node 2		
1	0.00C	24.28	-26.75	0.00	0.00	39.92 @ 4.500	21.89 @ 4.058

Classification and Effective Area (EN 1993: 2006)

Section (30.03 kg/m) 2 No. 152x152 UC 30 [Grade 43]
 Class = $F_n(b/T, d/t, f_y, N, M_y, M_z)$ 8.13, 19.02, 275, 0, 39.92, 0 (Axial: Non-Slender) Class 1

Auto Design Load Cases 1

Shear Capacity Check

$V_{y,Ed}/V_{pl,y,Rd}$ 23.316 / 366.908 = 0.064 OK

Moment Capacity Check M.c.y.Rd

$V_{y,Ed}/V_{pl,y,Rd}$ 5.132 / 366.908 = 0.014 Low Shear

$M_{c,y,Rd} = f_y \cdot W_{pl,y} / \gamma_{M0}$ 275 x 495.4/1 136.235 kN.m

$M_{y,Ed}/M_{c,y,Rd}$ 39.916 / 136.235 = 0.293 OK

Equivalent Uniform Moment Factor C1

$C_1 = f_n(M_1, M_2, -y)$ 28.6, 39.9, 0.716 1.152 Not Loaded

Lateral Buckling Check M.b.Rd

$L_e = 1.0 L$ 1 x 3.3 = 3.3 m

$M_{cr} = F_n(C_1, L_e, I_z, I_t, I_w, E)$ 1.152, 3.300, 1123, 21.04, 0.06150, 210000 285.338 kN.m

$\lambda_{LT} = \sqrt{W_{pl,y}/M_{cr}}$ $\sqrt{495.4 \times 275 / 285.338}$ 0.691

$CLT = F_n(\lambda_{LT}, \Phi_{LT}, \beta, \lambda_{LT0})$ 0.691, 0.729, 0.750, 0.400 0.874 Curve b

$CLT.mod = F_n(CL_T, \lambda_{LT}, k_c, f)$ 0.874, 0.691, 0.932, 0.967 0.904 6.3.2.3

$M_{b,Rd} = C W_{pl,y} \cdot f_y \leq M_{c,y,Rd}$ 0.904 x 495.4 x 275 \leq 136.235 = 123.200 kN.m

$M_{y,Ed}/M_{b,Rd}$ 39.916 / 123.2 0.324 OK

Deflection Check - Load Case 2

In-span $\delta \leq \text{Span}/360$ 21.89 \leq 8300 / 360 21.89 mm OK

STRUCTURAL CALCULATION



Project Ref	P22-0006.128				Project Title	Generic Mobile Home Lifting											
Doc Ref	P22-0006-HSC-Ca-S-128				Doc Title	Generic Mobile Home Lifting Assessment											
Version No	01	Date	Aug 23	Calcs By:	RJS	Date	Aug 23	Check By:	RS	Date	Aug 23	Appr'd By:	RJS	Sheet No	46	Sheet Version	01

BEAM & BEAM-PORTION (MEMBER)

C-01: Span 1

Span 1 Between 0.500 and 2.800 m, in Load Case 1

Member Loading and Member Forces

Loading Combination : 1 UT + 1.35 D1 + 1.5 L1

D1 UDLW -000.317 (kN/m)
 L1 PY -008.790 0.500 (kN,m)
 L1 PY -002.620 2.800 (kN,m)
 L1 PY -008.790 5.100 (kN,m)
 L1 PDLY -002.990 0.500 5.100 (kN,m,m)

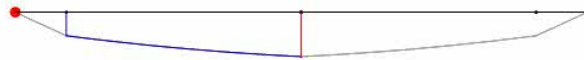

Member Forces in Load Case 1 and Maximum Deflection from Load Case 2

Span No.	Axial Force (kN)	Shear Force (kN)		Bending Moment (kNm)		Maximum Moment (kNm)	Maximum Deflection (mm @ m)
		End 1	End 2	Node 1	Node 2		
1	0.00C	18.59	-18.59	0.00	0.00	17.47 @ 2.800	9.87 @ 2.800

Classification and Effective Area (EN 1993: 2006)

Section (15.95 kg/m) 2 No. 152x89 UB 16 [Grade 43]
 Class = $F_n(b/T, d/t, f_y, N, M_y, M_z)$ 5.76, 27.07, 275, 0, 17.47, 0

(Axial: Non-Slender) Class 1

Auto Design Load Cases 1

Shear Capacity Check

$V_{y,Ed}/V_{pl,y,Rd}$ 18.376 / 259.658 =

0.071 OK

Moment Capacity Check M.c.y.Rd

$V_{y,Ed}/V_{pl,y,Rd}$ 1.964 / 259.658 =

0.008 Low Shear

$M_{c,y,Rd} = f_y \cdot W_{pl,y} / \gamma_{M0}$ 275 x 246.6/1

67.815 kN.m

$M_{y,Ed}/M_{c,y,Rd}$ 17.468 / 67.815 =

0.258 OK

Equivalent Uniform Moment Factor C1

$C_1 = f_n(M_1, M_2, -y)$ 9.2, 17.5, 0.529

1.278 Not Loaded

Lateral Buckling Check M.b.Rd

$L_e = 1.0 L$ 1 x 2.3 =

2.3 m

$M_{cr} = F_n(C_1, L_e, I_z, I_t, I_w, E)$ 1.278, 2.300, 181.2, 7.121, 0.009376, 210000

104.566 kN.m

$\lambda_{LT} = \sqrt{W \cdot f_y / M_{cr}}$ $\sqrt{246.6 \times 275 / 104.566}$

0.805

$CLT = F_n(\lambda_{LT}, \Phi_{LT}, \beta, \lambda_{LT0})$ 0.805, 0.812, 0.750, 0.400

0.814

$CLT.mod = F_n(CL_T, \lambda_{LT}, k_c, f)$ 0.814, 0.805, 0.884, 0.942

0.864

$M_{b,Rd} = C \cdot W_{pl,y} \cdot f_y \leq M_{c,y,Rd}$ 0.864 x 246.6 x 275 \leq 67.815 =

58.601 kN.m

$M_{y,Ed}/M_{b,Rd}$ 17.468 / 58.601

0.298 OK

Deflection Check - Load Case 2

In-span $\delta \leq \text{Span}/360$ 9.87 \leq 5600 / 360

9.87 mm OK

STRUCTURAL CALCULATION



Project Ref	P22-0006.128				Project Title	Generic Mobile Home Lifting											
Doc Ref	P22-0006-HSC-Ca-S-128				Doc Title	Generic Mobile Home Lifting Assessment											
Version No	01	Date	Aug 23	Calcs By:	RJS	Date	Aug 23	Check By:	RS	Date	Aug 23	Appr'd By:	RJS	Sheet No	47	Sheet Version	01

BEAM & BEAM-PORTION (MEMBER)

C-02: Span 1

Span 1 Between 0.500 and 3.050 m, in Load Case 1

Member Loading and Member Forces

Loading Combination : 1 UT + 1.35 D1 + 1.5 L1

D1 UDLW -000.317 (kN/m)
 L1 PY -009.380 0.500 (kN,m)
 L1 PY -002.910 3.050 (kN,m)
 L1 PY -009.380 5.600 (kN,m)
 L1 PDLY -003.315 0.500 5.600 (kN,m,m)

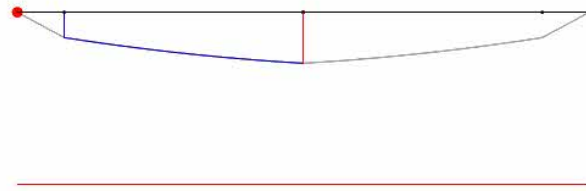

Member Forces in Load Case 1 and Maximum Deflection from Load Case 2

Span No.	Axial Force (kN)	Shear Force (kN)		Bending Moment (kNm)		Maximum Moment (kNm)	Maximum Deflection (mm @ m)
		End 1	End 2	Node 1	Node 2		
1	0.00C	20.04	-20.04	0.00	0.00	20.10 @ 3.050	13.32 @ 3.050

Classification and Effective Area (EN 1993: 2006)

Section (15.95 kg/m) 2 No. 152x89 UB 16 [Grade 43]
 Class = $F_n(b/T, d/t, f_y, N, M_y, M_z)$ 5.76, 27.07, 275, 0, 20.09, 0

(Axial: Non-Slender) Class 1

Auto Design Load Cases 1

Shear Capacity Check

$V_{y,Ed}/V_{pl,y,Rd}$ 19.829 / 259.658 = 0.076 OK

Moment Capacity Check M.c.y.Rd

$V_{y,Ed}/V_{pl,y,Rd}$ 2.183 / 259.658 = 0.008 Low Shear
 $M_{c,y,Rd} = f_y \cdot W_{pl,y} / \gamma_{M0}$ 275 x 246.6/1 = 67.815 kN.m
 $M_{y,Ed}/M_{c,y,Rd}$ 20.092 / 67.815 = 0.296 OK

Equivalent Uniform Moment Factor C1

$C_1 = f_n(M_1, M_2, -y)$ 10.0, 20.1, 0.496 1.303 Not Loaded

Lateral Buckling Check M.b.Rd

$L_e = 1.0 L$ 1 x 2.55 = 2.55 m
 $M_{cr} = F_n(C_1, L_e, I_z, I_t, I_w, E)$ 1.303, 2.550, 181.2, 7.121, 0.009376, 210000 92.561 kN.m
 $\lambda_{LT} = \sqrt{W \cdot f_y / M_{cr}}$ $\sqrt{246.6 \times 275 / 92.561}$ 0.856
 $C_{LT} = F_n(\lambda_{LT}, \Phi_{LT}, \beta, \lambda_{LT0})$ 0.856, 0.852, 0.750, 0.400 0.786 Curve b
 $C_{LT,mod} = F_n(C_{LT}, \lambda_{LT}, k_c, f)$ 0.786, 0.856, 0.876, 0.938 0.837 6.3.2.3
 $M_{b,Rd} = C \cdot W_{pl,y} \cdot f_y \leq M_{c,y,Rd}$ 0.837 x 246.6 x 275 \leq 67.815 = 56.775 kN.m
 $M_{y,Ed}/M_{b,Rd}$ 20.092 / 56.775 0.354 OK

Deflection Check - Load Case 2

In-span $\delta \leq \text{Span}/360$ 13.32 \leq 6100 / 360 13.32 mm OK

STRUCTURAL CALCULATION



Hibbert Smith Consulting Ltd – Structural & Civil Engineers
T: 07949 171 787 W: www.HibbertSmith.com

Project Ref	P22-0006.128				Project Title	Generic Mobile Home Lifting											
Doc Ref	P22-0006-HSC-Ca-S-128				Doc Title	Generic Mobile Home Lifting Assessment											
Version No	01	Date	Aug 23	Calcs By:	RJS	Date	Aug 23	Check By:	RS	Date	Aug 23	Appr'd By:	RJS	Sheet No	48	Sheet Version	01

BEAM & BEAM-PORTION (MEMBER)

C-03: Span 1

Span 1 Between 0.500 and 3.300 m, in Load Case 1

Member Loading and Member Forces

Loading Combination : 1 UT + 1.35 D1 + 1.5 L1

D1 UDLW -000.317 (kN/m)
L1 PY -009.980 0.500 (kN,m)
L1 PY -003.190 3.300 (kN,m)
L1 PY -009.980 6.100 (kN,m)
L1 PDLY -003.640 0.500 6.100 (kN,m,m)

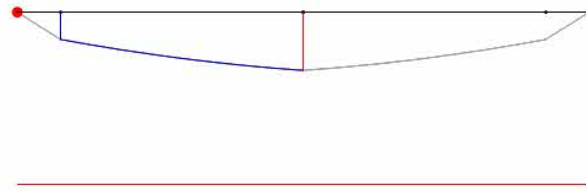

Member Forces in Load Case 1 and Maximum Deflection from Load Case 2

Span No.	Axial Force (kN)	Shear Force (kN)		Bending Moment (kNm)		Maximum Moment (kNm)	Maximum Deflection (mm @ m)
		End 1	End 2	Node 1	Node 2		
1	0.00C	21.50	-21.50	0.00	0.00	22.90 @ 3.300	17.58 @ 3.300

Classification and Effective Area (EN 1993: 2006)

Section (15.95 kg/m) 2 No. 152x89 UB 16 [Grade 43]
Class = $F_n(b/T, d/t, f_y, N, M_y, M_z)$ 5.76, 27.07, 275, 0, 22.89, 0

(Axial: Non-Slender) Class 1

Auto Design Load Cases 1

Shear Capacity Check

$V_{y,Ed}/V_{pl,y,Rd}$ 21.29 / 259.658 = 0.082 OK

Moment Capacity Check M.c.y.Rd

$V_{y,Ed}/V_{pl,y,Rd}$ 2.392 / 259.658 = 0.009 Low Shear

$M_{c,y,Rd} = f_y \cdot W_{pl,y} / \gamma_{M0}$ 275 x 246.6/1 = 67.815 kN.m

$M_{y,Ed}/M_{c,y,Rd}$ 22.892 / 67.815 = 0.338 OK

Equivalent Uniform Moment Factor C1

$C_1 = f_n(M_1, M_2, -y)$ 10.7, 22.9, 0.468 1.325 Not Loaded

Lateral Buckling Check M.b.Rd

$L_e = 1.0 L$ 1 x 2.8 = 2.8 m

$M_{cr} = F_n(C_1, L_e, I_z, I_t, I_w, E)$ 1.325, 2.800, 181.2, 7.121, 0.009376, 210000 = 83.171 kN.m

$\lambda_{LT} = \sqrt{W_{pl,y}/M_{cr}}$ $\sqrt{246.6 \times 275 / 83.171}$ = 0.903

$C_{LT} = F_n(\lambda_{LT}, \Phi_{LT}, \beta, \lambda_{LT0})$ 0.903, 0.891, 0.750, 0.400 = 0.758 Curve b

$C_{LT,mod} = F_n(C_{LT}, \lambda_{LT}, k_c, f)$ 0.758, 0.903, 0.869, 0.936 = 0.810 6.3.2.3

$M_{b,Rd} = C \cdot W_{pl,y} \cdot f_y \leq M_{c,y,Rd}$ 0.810 x 246.6 x 275 \leq 67.815 = 54.945 kN.m

$M_{y,Ed}/M_{b,Rd}$ 22.892 / 54.945 = 0.417 OK

Deflection Check - Load Case 2

In-span $\delta \leq \text{Span}/360$ 17.58 \leq 6600 / 360 17.58 mm OK

STRUCTURAL CALCULATION



Project Ref	P22-0006.128				Project Title	Generic Mobile Home Lifting											
Doc Ref	P22-0006-HSC-Ca-S-128				Doc Title	Generic Mobile Home Lifting Assessment											
Version No	01	Date	Aug 23	Calcs By:	RJS	Date	Aug 23	Check By:	RS	Date	Aug 23	Apprd By:	RJS	Sheet No	49	Sheet Version	01

BEAM & BEAM-PORION (MEMBER)

C-04: Span 1

Span 1 Between 0.500 and 3.550 m, in Load Case 1

Member Loading and Member Forces

Loading Combination : 1 UT + 1.35 D1 + 1.5 L1

D1 UDLW -000.456 (kN/m)
 L1 PY -010.570 0.500 (kN,m)
 L1 PY -003.480 3.550 (kN,m)
 L1 PY -010.570 6.600 (kN,m)
 L1 PDLY -003.965 0.500 6.600 (kN,m,m)

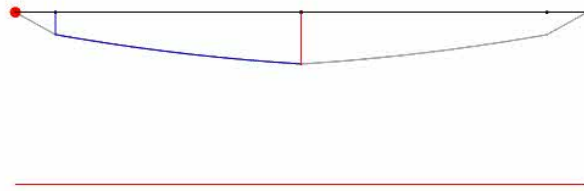

Member Forces in Load Case 1 and Maximum Deflection from Load Case 2

Span No.	Axial Force (kN)	Shear Force (kN)		Bending Moment (kNm)		Maximum Moment (kNm)	Maximum Deflection (mm @ m)
		End 1	End 2	Node 1	Node 2		
1	0.00C	23.62	-23.62	0.00	0.00	27.09 @ 3.550	15.23 @ 3.550

Classification and Effective Area (EN 1993: 2006)

Section (22.95 kg/m) 2 No. 152x152 UC 23 [Grade 43]
 Class = $F_n(b/T, d/t, f_y, N, M_y, M_z)$ 11.19, 21.31, 275, 0, 27.09, 0 (Axial: Non-Slender) Class 3

Effective Properties Area=58.48(29.24) cm², $W_{pl,y}$ =358.78(182) cm³, $W_{pl,z}$ =152.35(80.2) cm³
 Auto Design Load Cases 1

Shear Capacity Check

$V_{y,Ed}/V_{pl,y,Rd}$ 23.316 / 316.552 = 0.074 OK

Moment Capacity Check M.c.y.Rd

$V_{y,Ed}/V_{pl,y,Rd}$ 2.612 / 316.552 = 0.008 Low Shear
 $M_{c,y,Rd} = f_y \cdot W_{el,y} / \gamma_{M0}$ 275 x 328.26/1 = 90.272 kN.m
 $M_{y,Ed}/M_{c,y,Rd}$ 27.093 / 90.272 = 0.300 OK

Equivalent Uniform Moment Factor C1

$C_1 = f_n(M_1, M_2, -y)$ 11.7, 27.1, 0.433 1.351 Not Loaded

Lateral Buckling Check M.b.Rd

$L_e = 1.0 L$ 1 x 3.05 = 3.05 m
 $M_{cr} = F_n(C_1, L_e, I_z, I_t, I_w, E)$ 1.351, 3.050, 801.6, 9.27, 0.04235, 210000 234.930 kN.m
 $\lambda_{LT} = \sqrt{W_{pl,y}/M_{cr}}$ $\sqrt{358.8 \times 275 / 234.93}$ 0.620
 $C_{LT} = F_n(\lambda_{LT}, \Phi_{LT}, \beta, \lambda_{LT0})$ 0.620, 0.681, 0.750, 0.400 0.908 Curve b
 $C_{LT,mod} = F_n(C_{LT}, \lambda_{LT}, k_c, f)$ 0.908, 0.620, 0.860, 0.935 0.972 6.3.2.3
 $M_{b,Rd} = C W_{pl,y} \cdot f_y \leq M_{c,y,Rd}$ 0.972 x 358.8 x 275 \leq 90.272 = 87.702 kN.m
 $M_{y,Ed}/M_{b,Rd}$ 27.093 / 87.702 0.309 OK

Deflection Check - Load Case 2

In-span $\delta \leq \text{Span}/360$ 15.23 \leq 7100 / 360 15.23 mm OK

STRUCTURAL CALCULATION



Hibbert Smith Consulting Ltd – Structural & Civil Engineers
T: 07949 171 787 W: www.HibbertSmith.com

Project Ref	P22-0006.128				Project Title	Generic Mobile Home Lifting											
Doc Ref	P22-0006-HSC-Ca-S-128				Doc Title	Generic Mobile Home Lifting Assessment											
Version No	01	Date	Aug 23	Calcs By:	RJS	Date	Aug 23	Check By:	RS	Date	Aug 23	Appr'd By:	RJS	Sheet No	50	Sheet Version	01

BEAM & BEAM-PORTION (MEMBER)

C-05: Span 1

Span 1 Between 0.500 and 3.800 m, in Load Case 1

Member Loading and Member Forces

Loading Combination : 1 UT + 1.35 D1 + 1.5 L1

D1 UDLW -000.456 (kN/m)
L1 PY -011.160 0.500 (kN,m)
L1 PY -003.760 3.800 (kN,m)
L1 PY -011.160 7.100 (kN,m)
L1 PDLY -004.290 0.500 7.100 (kN,m,m)

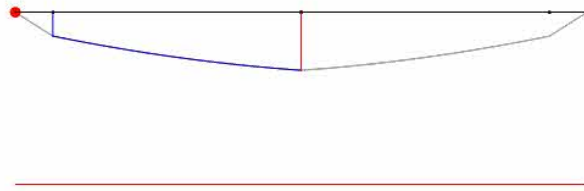

Member Forces in Load Case 1 and Maximum Deflection from Load Case 2

Span No.	Axial Force (kN)	Shear Force (kN)		Bending Moment (kNm)		Maximum Moment (kNm)	Maximum Deflection (mm @ m)
		End 1	End 2	Node 1	Node 2		
1	0.00C	25.12	-25.12	0.00	0.00	30.45 @ 3.800	19.43 @ 3.800

Classification and Effective Area (EN 1993: 2006)

Section (22.95 kg/m) 2 No. 152x152 UC 23 [Grade 43]
Class = $F_n(b/T, d/t, f_y, N, M_y, M_z)$ 11.19, 21.31, 275, 0, 30.44, 0 (Axial: Non-Slender) Class 3

Effective Properties Area=58.48(29.24) cm², $W_{pl,y}=358.78(182)$ cm³, $W_{pl,z}=152.35(80.2)$ cm³
Auto Design Load Cases 1

Shear Capacity Check

$V_{y,Ed}/V_{pl,y,Rd}$ 24.808 / 316.552 = 0.078 OK

Moment Capacity Check M.c.y.Rd

$V_{y,Ed}/V_{pl,y,Rd}$ 2.82 / 316.552 = 0.009 Low Shear
 $M_{c,y,Rd} = f_y \cdot W_{el,y} / \gamma_{M0}$ 275 x 328.26/1 = 90.272 kN.m
 $M_{y,Ed}/M_{c,y,Rd}$ 30.444 / 90.272 = 0.337 OK

Equivalent Uniform Moment Factor C1

$C_1 = f_n(M_1, M_2, -y)$ 12.5, 30.4, 0.410 1.370 Not Loaded

Lateral Buckling Check M.b.Rd

$l_e = 1.0 L$ 1 x 3.3 = 3.3 m
 $M_{cr} = F_n(C_1, l_e, I_z, I_t, I_w, E)$ 1.370, 3.300, 801.6, 9.27, 0.04235, 210000 210.964 kN.m
 $\lambda_{LT} = \sqrt{W_{pl,y}/M_{cr}}$ $\sqrt{358.8 \times 275 / 210.964}$ 0.654
 $C_{LT} = F_n(\lambda_{LT}, \Phi_{LT}, \beta, \lambda_{LT0})$ 0.654, 0.704, 0.750, 0.400 0.892 Curve b
 $C_{LT,mod} = F_n(C_{LT}, \lambda_{LT}, k_c, f)$ 0.892, 0.654, 0.854, 0.930 0.959 6.3.2.3
 $M_{b,Rd} = C W_{pl,y} \cdot f_y \leq M_{c,y,Rd}$ 0.959 x 358.8 x 275 \leq 90.272 = 86.555 kN.m
 $M_{y,Ed}/M_{b,Rd}$ 30.444 / 86.555 0.352 OK

Deflection Check - Load Case 2

In-span $\delta \leq$ Span/360 19.43 \leq 7600 / 360 19.43 mm OK

STRUCTURAL CALCULATION



Project Ref		P22-0006.128				Project Title		Generic Mobile Home Lifting								
Doc Ref		P22-0006-HSC-Ca-S-128				Doc Title		Generic Mobile Home Lifting Assessment								
Version No	Date	Aug 23	Calcs By:	RJS	Date	Aug 23	Check By:	RS	Date	Aug 23	Appr'd By:	RJS	Sheet No	51	Sheet Version	01

Edge Beams (Selected Cases)

BEAM & BEAM-PORION (MEMBER) A-104: Span 2 Span 2 in Load Case 1

Member Loading and Member Forces
Loading Combination : 1 UT + 1.35 D1 + 1.5 L1

D1 UDLW -000.178 (kN/m)
L1 PY -014.250 1.460 (kN,m)
L1 PY -014.250 3.310 (kN,m)

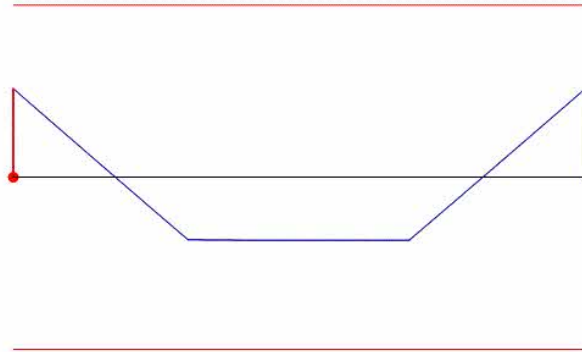

Member Forces in Load Case 1 and Maximum Deflection from Load Case 2

Span No.	Axial Force (kN)	Shear Force (kN)		Bending Moment (kNm)		Maximum Moment (kNm)	Maximum Deflection (mm @ m)
		End 1	End 2	Node 1	Node 2		
2	0.00C	22.00	-21.90	-18.69	-18.65	13.33 @ 2.589	9.59 @ 2.390

Classification and Effective Area (EN 1993: 2006)

Section (17.9 kg/m) 150x75 PFC 17.9 [Grade 43]
Class = $F_n(b/T, d/t, f_y, N, M_y, M_z)$ 7.5, 19.27, 275, 0, 18.69, 0 (Axial: Non-Slender) Class 1

Auto Design Load Cases 1

Moment Capacity Check M.c.y.Rd

$V_{y,Ed}/V_{pl,y,Rd}$ 22.002 / 151.627 = 0.145 Low Shear
 $M_{c,y,Rd} = f_y \cdot W_{pl,y} / \gamma_{M0}$ 275 x 132 / 1 36.3 kN.m
 $M_{y,Ed}/M_{c,y,Rd}$ -18.691 / 36.3 = 0.515 OK

Equivalent Uniform Moment Factor C1

$C_1 = f_n(M_1, M_2, M_0, \sim y, \sim m)$ -18.7, -18.6, 32.0, 0.998, -1.713 1.769 Uniform

Lateral Buckling Check M.b.Rd

$l_e = 1.0 L$ 1 x 4.78 = 4.78 m
 $M_{cr} = F_n(C_1, l_e, I_z, I_t, I_w, E)$ 1.769, 4.780, 131.0, 6.1, 0.004670, 210000 44.601 kN.m
 $\lambda_{LT} = \sqrt{W_{pl,y}/M_{cr}}$ $\sqrt{132 \times 275 / 44.601}$ 0.902
 $C_{LT} = F_n(\lambda_{LT}, \Phi_{LT}, \beta, \lambda_{LT0})$ 0.902, 0.996, 0.750, 0.400 0.620 Curve d
 $C_{LT,mod} = F_n(C_{LT}, \lambda_{LT}, k_c, f)$ 0.620, 0.902, 0.752, 0.879 0.705 6.3.2.3
 $M_{b,Rd} = C W_{pl,y} \cdot f_y \leq M_{c,y,Rd}$ 0.705 x 132.0 x 275 \leq 36.300 = 25.603 kN.m
 $M_{y,Ed}/M_{b,Rd}$ 18.691 / 25.603 0.730 OK

Deflection Check - Load Case 2

In-span $\delta \leq \text{Span}/360$ 9.59 \leq 4780 / 360 9.59 mm OK

STRUCTURAL CALCULATION



Hibbert Smith Consulting Ltd – Structural & Civil Engineers
T: 07949 171 787 W: www.HibbertSmith.com

Project Ref		P22-0006.128			Project Title		Generic Mobile Home Lifting									
Doc Ref		P22-0006-HSC-Ca-S-128			Doc Title		Generic Mobile Home Lifting Assessment									
Version No	Date	Aug 23	Calcs By:	RJS	Date	Aug 23	Check By:	RS	Date	Aug 23	Appr'd By:	RJS	Sheet No	52	Sheet Version	01

BEAM & BEAM-PORTION (MEMBER)

A-105: Span 2

Span 2 in Load Case 1

Member Loading and Member Forces

Loading Combination : 1 UT + 1.35 D1 + 1.5 L1

D1 UDLW -000.202 (kN/m)
L1 PY -014.250 0.890 (kN,m)
L1 PY -014.250 2.520 (kN,m)
L1 PY -014.250 4.140 (kN,m)

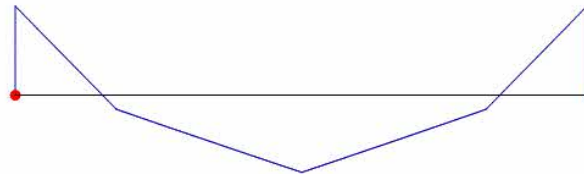

Member Forces in Load Case 1 and Maximum Deflection from Load Case 2

Span No.	Axial Force (kN)	Shear Force (kN)		Bending Moment (kNm)		Maximum Moment (kNm)	Maximum Deflection (mm @ m)
		End 1	End 2	Node 1	Node 2		
2	0.00C	32.72	-32.78	-25.06	-25.11	21.68 @ 2.520	8.46 @ 2.515

Classification and Effective Area (EN 1993: 2006)

Section (20.3 kg/m) 180x75 PFC 20.3 [Grade 43]
Class = $F_n(b/T, d/t, f_y, N, M_y, M_z)$ 7.14, 22.5, 275, 0, 25.11, 0 (Axial: Non-Slender) Class 1

Auto Design Load Cases 1

Moment Capacity Check M.c.y.Rd

$V_{y,Ed}/V_{pl,y,Rd}$ 32.78 / 191.161 = 0.171 Low Shear
 $M_{c,y,Rd} = f_y \cdot W_{pl,y} / \gamma_{M0}$ 275 x 176 / 1 48.4 kN.m
 $M_{y,Ed}/M_{c,y,Rd}$ -25.112 / 48.4 = 0.519 OK

Equivalent Uniform Moment Factor C1

$C_1 = f_n(M_1, M_2, M_0, -y, -m)$ -25.0, -25.1, 46.7, 0.998, -1.861 1.465 Uniform

Lateral Buckling Check M.b.Rd

$L_e = 1.0 L$ 1 x 5.03 = 5.03 m
 $M_{cr} = F_n(C_1, L_e, I_z, I_t, I_w, E)$ 1.465, 5.030, 146.0, 7.34, 0.007540, 210000 40.995 kN.m
 $\lambda_{LT} = \sqrt{W_{pl,y} / M_{cr}}$ $\sqrt{176 \times 275 / 40.995}$ 1.087
 $CLT = F_n(\lambda_{LT}, \Phi_{LT}, \beta, \lambda_{LT0})$ 1.087, 1.204, 0.750, 0.400 0.512 Curve d
 $CLT.mod = F_n(CL_T, \lambda_{LT}, k_c, f)$ 0.512, 1.087, 0.826, 0.927 0.552 6.3.2.3
 $M_{b,Rd} = C \cdot W_{pl,y} \cdot f_y \leq M_{c,y,Rd}$ 0.552 x 176.0 x 275 \leq 48.400 = 26.708 kN.m
 $M_{y,Ed}/M_{b,Rd}$ 25.112 / 26.708 0.940 OK

Deflection Check - Load Case 2

In-span $\delta \leq \text{Span}/360$ 8.46 \leq 5030 / 360 8.46 mm OK

STRUCTURAL CALCULATION



Hibbert Smith Consulting Ltd – Structural & Civil Engineers
T: 07949 171 787 W: www.HibbertSmith.com

Project Ref		P22-0006.128				Project Title		Generic Mobile Home Lifting								
Doc Ref		P22-0006-HSC-Ca-S-128				Doc Title		Generic Mobile Home Lifting Assessment								
Version No	Date	Aug 23	Calcs By:	RJS	Date	Aug 23	Check By:	RS	Date	Aug 23	Appr'd By:	RJS	Sheet No	53	Sheet Version	01

BEAM & BEAM-PORION (MEMBER)

A-108: Span 2

Span 2 in Load Case 1

Member Loading and Member Forces

Loading Combination : 1 UT + 1.35 D1 + 1.5 L1

D1 UDLW -000.233	(kN/m)
L1 PY -014.250 0.500	(kN,m)
L1 PY -014.250 2.180	(kN,m)
L1 PY -014.250 3.850	(kN,m)
L1 PY -014.250 5.530	(kN,m)

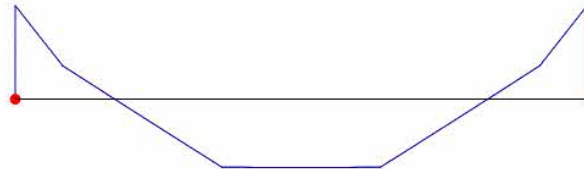

Member Forces in Load Case 1 and Maximum Deflection from Load Case 2

Span No.	Axial Force (kN)	Shear Force (kN)		Bending Moment (kNm)		Maximum Moment (kNm)	Maximum Deflection (mm @ m)
		End 1	End 2	Node 1	Node 2		
2	0.00C	43.70	-43.70	-33.96	-33.96	24.76 @ 3.015	11.69 @ 3.015

Classification and Effective Area (EN 1993: 2006)

Section (23.4 kg/m) 200x75 PFC 23.4 [Grade 43]
Class = $F_n(b/T, d/t, f_y, N, M_y, M_z)$ 6, 25.17, 275, 0, 33.96, 0 (Axial: Non-Slender) Class 1

Auto Design Load Cases 1

Moment Capacity Check M.c.y.Rd

$V_{y,Ed}/V_{pl,y,Rd}$ 43.698 / 212.754 = 0.205 Low Shear
 $M_{c,y,Rd} = f_y \cdot W_{pl,y} / \gamma_{M0}$ 275 x 227/1 = 62.425 kN.m
 $M_{y,Ed}/M_{c,y,Rd}$ -33.958 / 62.425 = 0.544 OK

Equivalent Uniform Moment Factor C1

$C_1 = f_n(M_1, M_2, M_0, -y, -m)$ -33.9, -33.9, 58.7, 1.000, -1.730 1.732 Uniform

Lateral Buckling Check M.b.Rd

$L_e = 1.0 L$ 1 x 6.03 = 6.03 m
 $M_{cr} = F_n(C_1, L_e, I_z, I_t, I_w, E)$ 1.732, 6.030, 170.0, 11.1, 0.01070, 210000 52.773 kN.m
 $\lambda_{LT} = \sqrt{W \cdot f_y / M_{cr}}$ $\sqrt{227 \times 275 / 52.773}$ 1.088
 $CLT = F_n(\lambda_{LT}, \Phi_{LT}, \beta, \lambda_{LT0})$ 1.088, 1.205, 0.750, 0.400 0.511 Curve d
 $CLT.mod = F_n(CL_T, \lambda_{LT}, k_c, f)$ 0.511, 1.088, 0.760, 0.900 0.568 6.3.2.3
 $M_{b,Rd} = C \cdot W_{pl,y} \cdot f_y \leq M_{c,y,Rd}$ 0.568 x 227.0 x 275 \leq 62.425 = 35.466 kN.m
 $M_{y,Ed}/M_{b,Rd}$ 33.958 / 35.466 0.957 OK

Deflection Check - Load Case 2

In-span $\delta \leq \text{Span}/360$ 11.69 \leq 6030 / 360 11.69 mm OK

STRUCTURAL CALCULATION



Hibbert Smith Consulting Ltd – Structural & Civil Engineers
T: 07949 171 787 W: www.HibbertSmith.com

Project Ref		P22-0006.128			Project Title		Generic Mobile Home Lifting									
Doc Ref		P22-0006-HSC-Ca-S-128			Doc Title		Generic Mobile Home Lifting Assessment									
Version No	Date	Aug 23	Calcs By:	RJS	Date	Aug 23	Check By:	RS	Date	Aug 23	Appr'd By:	RJS	Sheet No	54	Sheet Version	01

BEAM & BEAM-PORTION (MEMBER)

A-110: Span 2

Span 2 in Load Case 1

Member Loading and Member Forces

Loading Combination : 1 UT + 1.35 D1 + 1.5 L1

D1 UDLW	-000.255	(kN/m)
L1 PY	-014.250 0.530	(kN,m)
L1 PY	-014.250 2.350	(kN,m)
L1 PY	-014.250 4.180	(kN,m)
L1 PY	-014.250 6.000	(kN,m)

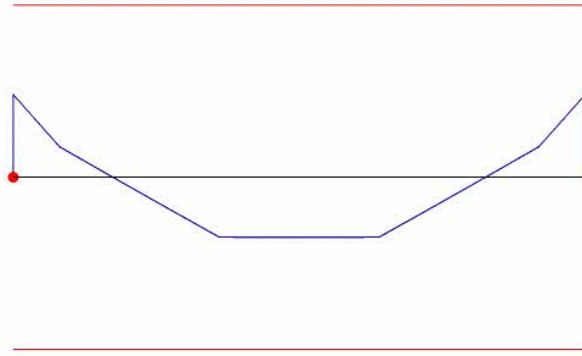

Member Forces in Load Case 1 and Maximum Deflection from Load Case 2

Span No.	Axial Force (kN)	Shear Force (kN)		Bending Moment (kNm)		Maximum Moment (kNm)	Maximum Deflection (mm @ m)
		End 1	End 2	Node 1	Node 2		
2	0.00C	43.87	-43.87	-36.70	-36.70	26.69 @ 3.265	10.54 @ 3.265

Classification and Effective Area (EN 1993: 2006)

Section (25.7 kg/m) 230x75 PFC 25.7 [Grade 43]

Class = $F_n(b/T, d/t, f_y, N, M_y, M_z)$ 6, 27.85, 275, 0, 36.7, 0

(Axial: Non-Slender)

Class 1

Auto Design Load Cases 1

Moment Capacity Check M.c.y.Rd

$V_{y,Ed}/V_{pl,y,Rd}$ 43.874 / 258.202 = 0.17

$M_{c,y,Rd} = f_y \cdot W_{pl,y} / \gamma_{M0}$ 275 x 278 / 1 = 76.45 kN.m

$M_{y,Ed}/M_{c,y,Rd}$ -36.704 / 76.45 = 0.480

Low Shear

OK

Equivalent Uniform Moment Factor C1

$C_1 = f_n(M_1, M_2, M_0, -y, -m)$ -36.7, -36.7, 63.3, 1.000, -1.728

1.737

Uniform

Lateral Buckling Check M.b.Rd

$L_e = 1.0 L$ 1 x 6.53 = 6.53 m

$M_{cr} = F_n(C_1, L_e, I_z, I_t, I_w, E)$ 1.737, 6.530, 181.0, 11.8, 0.01530, 210000 = 52.212 kN.m

$\lambda_{LT} = \sqrt{W \cdot f_y / M_{cr}}$ $\sqrt{278 \times 275 / 52.212}$ = 1.210

$CLT = F_n(\lambda_{LT}, \Phi_{LT}, \beta, \lambda_{LT0})$ 1.210, 1.357, 0.750, 0.400 = 0.451

$CLT.mod = F_n(CL_T, \lambda_{LT}, k_c, f)$ 0.451, 1.210, 0.759, 0.920 = 0.490

$M_{b,Rd} = C \cdot W_{pl,y} \cdot f_y \leq M_{c,y,Rd}$ 0.490 x 278.0 x 275 \leq 76.450 = 37.452 kN.m

$M_{y,Ed}/M_{b,Rd}$ 36.704 / 37.452 = 0.980

Curve d

6.3.2.3

OK

Deflection Check - Load Case 2

In-span $\delta \leq \text{Span}/360$ 10.54 \leq 6530 / 360

10.54 mm

OK

STRUCTURAL CALCULATION



Project Ref	P22-0006.128				Project Title	Generic Mobile Home Lifting											
Doc Ref	P22-0006-HSC-Ca-S-128				Doc Title	Generic Mobile Home Lifting Assessment											
Version No	01	Date	Aug 23	Calcs By:	RJS	Date	Aug 23	Check By:	RS	Date	Aug 23	Apprd By:	RJS	Sheet No	55	Sheet Version	01

BEAM & BEAM-PORTION (MEMBER) A-111: Span 2 Span 2 in Load Case 1

Member Loading and Member Forces
Loading Combination : 1 UT + 1.35 D1 + 1.5 L1

D1 UDLW	-000.296	(kN/m)
L1 PY	-014.250 0.550	(kN,m)
L1 PY	-014.250 2.440	(kN,m)
L1 PY	-014.250 4.330	(kN,m)
L1 PY	-014.250 6.220	(kN,m)

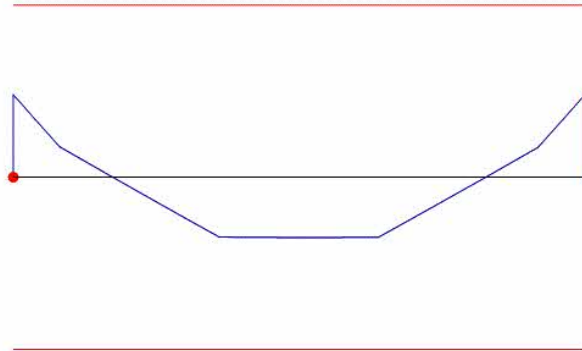

Member Forces in Load Case 1 and Maximum Deflection from Load Case 2

Span No.	Axial Force (kN)	Shear Force (kN)		Bending Moment (kNm)		Maximum Moment (kNm)	Maximum Deflection (mm @ m)
		End 1	End 2	Node 1	Node 2		
2	0.00C	44.16	-44.05	-38.38	-38.44	28.01 @ 3.537	12.89 @ 3.390

Classification and Effective Area (EN 1993: 2006)

Section (29.7 kg/m)	200x90 PFC 29.7 [Grade 43]		
Class = $F_n(b/T, d/t, f_y, N, M_y, M_z)$	6.43, 21.14, 275, 0, 38.44, 0	(Axial: Non-Slender)	Class 1
Auto Design Load Cases	1		

Shear Capacity Check

$V_{y.Ed}/V_{pl.y.Rd}$	44.158 / 243.873 =	0.181	OK
------------------------	--------------------	-------	----

Moment Capacity Check M.c.y.Rd

$V_{y.Ed}/V_{pl.y.Rd}$	44.051 / 243.873 =	0.181	Low Shear
$M_{c.y.Rd} = f_y \cdot W_{pl.y} / \gamma_{M0}$	275 x 291/1	80.025 kN.m	
$M_{y.Ed}/M_{c.y.Rd}$	-38.444 / 80.025 =	0.480	OK

Equivalent Uniform Moment Factor C1

$C_1 = f_n(M_1, M_2, M_0, \sim y, \sim m)$	-38.3, -38.4, 66.4, 0.998, -1.728	1.733	Uniform
--	-----------------------------------	-------	---------

Lateral Buckling Check M.b.Rd

$L_e = 1.0 L$	1 x 6.78 =	6.78 m	
$M_{cr} = F_n(C_1, L_e, I_z, I_t, I_w, E)$	1.733, 6.780, 314.0, 18.3, 0.01970, 210000	81.636 kN.m	
$\lambda_{LT} = \sqrt{W \cdot f_y / M_{cr}}$	$\sqrt{291 \times 275 / 81.636}$	0.990	
$C_{LT} = F_n(\lambda_{LT}, \Phi_{LT}, \beta, \lambda_{LT0})$	0.990, 1.092, 0.750, 0.400	0.566	Curve d
$C_{LT.mod} = F_n(C_{LT}, \lambda_{LT}, k_c, f)$	0.566, 0.990, 0.760, 0.888	0.637	6.3.2.3
$M_{b.Rd} = C \cdot W_{pl.y} \cdot f_y \leq M_{c.y.Rd}$	0.637 x 291.0 x 275 \leq 80.025 =	50.951 kN.m	
$M_{y.Ed}/M_{b.Rd}$	38.444 / 50.951	0.755	OK

Deflection Check - Load Case 2

In-span $\delta \leq \text{Span}/360$	12.89 \leq 6780 / 360	12.89 mm	OK
---------------------------------------	-------------------------	----------	----

STRUCTURAL CALCULATION



Hibbert Smith Consulting Ltd – Structural & Civil Engineers
T: 07949 171 787 W: www.HibbertSmith.com

Project Ref	P22-0006.128				Project Title	Generic Mobile Home Lifting											
Doc Ref	P22-0006-HSC-Ca-S-128				Doc Title	Generic Mobile Home Lifting Assessment											
Version No	01	Date	Aug 23	Calcs By:	RJS	Date	Aug 23	Check By:	RS	Date	Aug 23	Apprd By:	RJS	Sheet No	56	Sheet Version	01

BEAM & BEAM-PORTION (MEMBER)

B-104: Span 2

Span 2 in Load Case 1

Member Loading and Member Forces

Loading Combination : 1 UT + 1.35 D1 + 1.5 L1

D1 UDLW -000.178 (kN/m)
L1 PY -016.250 1.460 (kN,m)
L1 PY -016.250 3.310 (kN,m)

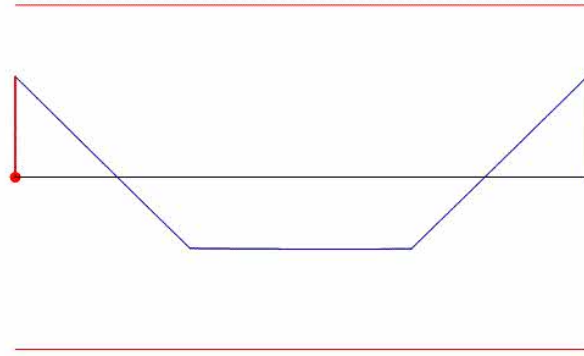

Member Forces in Load Case 1 and Maximum Deflection from Load Case 2

Span No.	Axial Force (kN)	Shear Force (kN)		Bending Moment (kNm)		Maximum Moment (kNm)	Maximum Deflection (mm @ m)
		End 1	End 2	Node 1	Node 2		
2	0.00C	25.01	-24.89	-21.26	-21.22	15.16 @ 2.589	10.93 @ 2.390

Classification and Effective Area (EN 1993: 2006)

Section (17.9 kg/m) 150x75 PFC 17.9 [Grade 43]
Class = $F_n(b/T, d/t, f_y, N, M_y, M_z)$ 7.5, 19.27, 275, 0, 21.26, 0 (Axial: Non-Slender) Class 1

Auto Design Load Cases 1

Moment Capacity Check M.c.y.Rd

$V_{y,Ed}/V_{pl,y,Rd}$ 25.009 / 151.627 = 0.165 Low Shear
 $M_{c,y,Rd} = f_y \cdot W_{pl,y} / \gamma_{M0}$ 275 x 132 / 1 36.3 kN.m
 $M_{y,Ed}/M_{c,y,Rd}$ -21.26 / 36.3 = 0.586 OK

Equivalent Uniform Moment Factor C1

$C_1 = f_n(M_1, M_2, M_0, -y, -m)$ -21.2, -21.2, 36.4, 0.998, -1.713 1.769 Uniform

Lateral Buckling Check M.b.Rd

$L_e = 1.0 L$ 1 x 4.78 = 4.78 m
 $M_{cr} = F_n(C_1, L_e, I_z, I_t, I_w, E)$ 1.769, 4.780, 131.0, 6.1, 0.004670, 210000 44.611 kN.m
 $\lambda_{LT} = \sqrt{W_{pl,y}/M_{cr}}$ $\sqrt{132 \times 275 / 44.611}$ 0.902
 $CLT = F_n(\lambda_{LT}, \Phi_{LT}, \beta, \lambda_{LT0})$ 0.902, 0.996, 0.750, 0.400 0.620 Curve d
 $CLT.mod = F_n(CL_T, \lambda_{LT}, k_c, f)$ 0.620, 0.902, 0.752, 0.878 0.705 6.3.2.3
 $M_{b,Rd} = C \cdot W_{pl,y} \cdot f_y \leq M_{c,y,Rd}$ 0.705 x 132.0 x 275 \leq 36.300 = 25.607 kN.m
 $M_{y,Ed}/M_{b,Rd}$ 21.26 / 25.607 0.830 OK

Deflection Check - Load Case 2

In-span $\delta \leq \text{Span}/360$ 10.93 \leq 4780 / 360 10.93 mm OK

STRUCTURAL CALCULATION



Hibbert Smith Consulting Ltd – Structural & Civil Engineers
T: 07949 171 787 W: www.HibbertSmith.com

Project Ref		P22-0006.128				Project Title		Generic Mobile Home Lifting								
Doc Ref		P22-0006-HSC-Ca-S-128				Doc Title		Generic Mobile Home Lifting Assessment								
Version No	Date	Aug 23	Calcs By:	RJS	Date	Aug 23	Check By:	RS	Date	Aug 23	Appr'd By:	RJS	Sheet No	57	Sheet Version	01

BEAM & BEAM-PORTION (MEMBER)

B-107: Span 2

Span 2 in Load Case 1

Member Loading and Member Forces

Loading Combination : 1 UT + 1.35 D1 + 1.5 L1

D1 UDLW -000.233 (kN/m)
L1 PY -016.250 0.970 (kN,m)
L1 PY -016.250 2.770 (kN,m)
L1 PY -016.250 4.560 (kN,m)

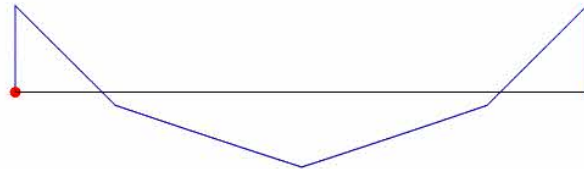

Member Forces in Load Case 1 and Maximum Deflection from Load Case 2

Span No.	Axial Force (kN)	Shear Force (kN)		Bending Moment (kNm)		Maximum Moment (kNm)	Maximum Deflection (mm @ m)
		End 1	End 2	Node 1	Node 2		
2	0.00C	37.40	-37.46	-31.37	-31.40	27.15 @ 2.770	8.92 @ 2.765

Classification and Effective Area (EN 1993: 2006)

Section (23.4 kg/m) 200x75 PFC 23.4 [Grade 43]
Class = $F_n(b/T, d/t, f_y, N, M_y, M_z)$ 6, 25.17, 275, 0, 31.41, 0 (Axial: Non-Slender) Class 1

Auto Design Load Cases 1

Moment Capacity Check M.c.y.Rd

$V_{y,Ed}/V_{pl,y,Rd}$ 37.46 / 212.754 = 0.176 Low Shear
 $M_{c,y,Rd} = f_y \cdot W_{pl,y} / \gamma_{M0}$ 275 x 227/1 = 62.425 kN.m
 $M_{y,Ed}/M_{c,y,Rd}$ -31.405 / 62.425 = 0.503 OK

Equivalent Uniform Moment Factor C1

$C_1 = f_n(M_1, M_2, M_0, -y, -m)$ -31.3, -31.4, 58.4, 0.999, -1.863 1.463 Uniform

Lateral Buckling Check M.b.Rd

$L_e = 1.0 L$ 1 x 5.53 = 5.53 m
 $M_{cr} = F_n(C_1, L_e, I_z, I_t, I_w, E)$ 1.463, 5.530, 170.0, 11.1, 0.01070, 210000 48.872 kN.m
 $\lambda_{LT} = \sqrt{W_{pl,y}/M_{cr}}$ $\sqrt{227 \times 275 / 48.872}$ 1.130
 $CLT = F_n(\lambda_{LT}, \Phi_{LT}, \beta, \lambda_{LT0})$ 1.130, 1.256, 0.750, 0.400 0.489 Curve d
 $CLT.mod = F_n(CL_T, \lambda_{LT}, k_c, f)$ 0.489, 1.130, 0.827, 0.932 0.525 6.3.2.3
 $M_{b,Rd} = C \cdot W_{pl,y} \cdot f_y \leq M_{c,y,Rd}$ 0.525 x 227.0 x 275 \leq 62.425 = 32.753 kN.m
 $M_{y,Ed}/M_{b,Rd}$ 31.405 / 32.753 0.959 OK

Deflection Check - Load Case 2

In-span $\delta \leq \text{Span}/360$ 8.92 \leq 5530 / 360 8.92 mm OK

STRUCTURAL CALCULATION



Hibbert Smith Consulting Ltd – Structural & Civil Engineers
T: 07949 171 787 W: www.HibbertSmith.com

Project Ref		P22-0006.128			Project Title		Generic Mobile Home Lifting									
Doc Ref		P22-0006-HSC-Ca-S-128			Doc Title		Generic Mobile Home Lifting Assessment									
Version No	Date	Aug 23	Calcs By:	RJS	Date	Aug 23	Check By:	RS	Date	Aug 23	Appr'd By:	RJS	Sheet No	58	Sheet Version	01

BEAM & BEAM-PORTION (MEMBER)

B-108: Span 2

Span 2 in Load Case 1

Member Loading and Member Forces

Loading Combination : 1 UT + 1.35 D1 + 1.5 L1

D1 UDLW	-000.255	(kN/m)
L1 PY	-016.250 0.500	(kN,m)
L1 PY	-016.250 2.180	(kN,m)
L1 PY	-016.250 3.850	(kN,m)
L1 PY	-016.250 5.530	(kN,m)

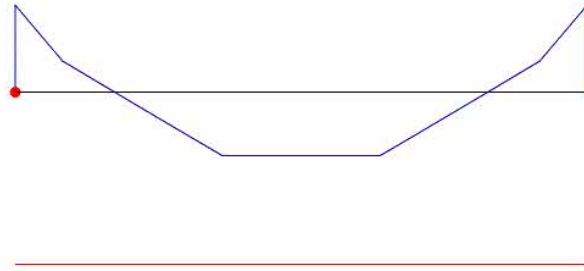

Member Forces in Load Case 1 and Maximum Deflection from Load Case 2

Span No.	Axial Force (kN)	Shear Force (kN)		Bending Moment (kNm)		Maximum Moment (kNm)	Maximum Deflection (mm @ m)
		End 1	End 2	Node 1	Node 2		
2	0.00C	49.79	-49.79	-38.69	-38.69	28.20 @ 3.015	9.53 @ 3.015

Classification and Effective Area (EN 1993: 2006)

Section (25.7 kg/m) 230x75 PFC 25.7 [Grade 43]
 Class = $F_n(b/T, d/t, f_y, N, M_y, M_z)$ 6, 27.85, 275, 0, 38.69, 0 (Axial: Non-Slender) Class 1

Auto Design Load Cases 1

Moment Capacity Check M.c.y.Rd

$V_{y.Ed}/V_{pl.y.Rd}$ 49.788 / 258.202 = 0.193 Low Shear
 $M_{c.y.Rd} = f_y \cdot W_{pl.y} / \gamma_{M0}$ 275 x 278 / 1 76.45 kN.m
 $M_{y.Ed}/M_{c.y.Rd}$ -38.688 / 76.45 = 0.506 OK

Equivalent Uniform Moment Factor C1

$C_1 = f_n(M_1, M_2, M_0, -y, -m)$ -38.6, -38.6, 66.8, 1.000, -1.730 1.733 Uniform

Lateral Buckling Check M.b.Rd

$L_e = 1.0 L$ 1 x 6.03 = 6.03 m
 $M_{cr} = F_n(C_1, L_e, I_z, I_t, I_w, E)$ 1.733, 6.030, 181.0, 11.8, 0.01530, 210000 56.760 kN.m
 $\lambda_{LT} = \sqrt{W \cdot f_y / M_{cr}}$ $\sqrt{278 \times 275 / 56.76}$ 1.161
 $CLT = F_n(\lambda_{LT}, \Phi_{LT}, \beta, \lambda_{LT0})$ 1.161, 1.294, 0.750, 0.400 0.474 Curve d
 $CLT.mod = F_n(CL_T, \lambda_{LT}, k_c, f)$ 0.474, 1.161, 0.760, 0.911 0.520 6.3.2.3
 $M_{b.Rd} = C \cdot W_{pl.y} \cdot f_y \leq M_{c.y.Rd}$ 0.520 x 278.0 x 275 \leq 76.450 = 39.781 kN.m
 $M_{y.Ed}/M_{b.Rd}$ 38.688 / 39.781 0.973 OK

Deflection Check - Load Case 2

In-span $\delta \leq \text{Span}/360$ 9.53 \leq 6030 / 360 9.53 mm OK

STRUCTURAL CALCULATION



Hibbert Smith Consulting Ltd – Structural & Civil Engineers
T: 07949 171 787 W: www.HibbertSmith.com

Project Ref	P22-0006.128				Project Title	Generic Mobile Home Lifting											
Doc Ref	P22-0006-HSC-Ca-S-128				Doc Title	Generic Mobile Home Lifting Assessment											
Version No	01	Date	Aug 23	Calcs By:	RJS	Date	Aug 23	Check By:	RS	Date	Aug 23	Appr'd By:	RJS	Sheet No	59	Sheet Version	01

BEAM & BEAM-PORTION (MEMBER)

B-109: Span 2

Span 2 in Load Case 1

Member Loading and Member Forces

Loading Combination : 1 UT + 1.35 D1 + 1.5 L1

D1 UDLW	-000.274	(kN/m)
L1 PY	-016.250 0.510	(kN,m)
L1 PY	-016.250 2.260	(kN,m)
L1 PY	-016.250 4.010	(kN,m)
L1 PY	-016.250 5.760	(kN,m)

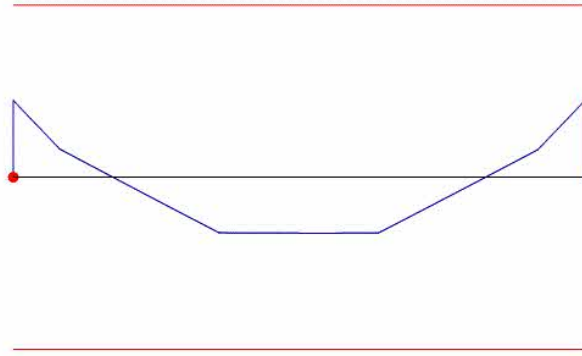

Member Forces in Load Case 1 and Maximum Deflection from Load Case 2

Span No.	Axial Force (kN)	Shear Force (kN)		Bending Moment (kNm)		Maximum Moment (kNm)	Maximum Deflection (mm @ m)
		End 1	End 2	Node 1	Node 2		
2	0.00C	49.98	-49.85	-40.24	-40.32	29.31 @ 3.277	8.14 @ 3.140

Classification and Effective Area (EN 1993: 2006)

Section (27.6 kg/m)	260x75 PFC 27.6 [Grade 43]		
Class = $F_n(b/T, d/t, f_y, N, M_y, M_z)$	6.25, 30.29, 275, 0, 40.32, 0	(Axial: Non-Slender)	Class 1

Auto Design Load Cases 1

Shear Capacity Check

$$V_{y,Ed}/V_{pl,y,Rd} = 49.977 / 307.699 = 0.162 \quad \text{OK}$$

Moment Capacity Check M.c.y.Rd

$$V_{y,Ed}/V_{pl,y,Rd} = 49.846 / 307.699 = 0.162 \quad \text{Low Shear}$$

$$M_{c,y,Rd} = f_y \cdot W_{pl,y} / \gamma_{M0} = 275 \times 328 / 1 = 90.2 \text{ kN.m}$$

$$M_{y,Ed}/M_{c,y,Rd} = -40.316 / 90.2 = 0.447 \quad \text{OK}$$

Equivalent Uniform Moment Factor C1

$$C_1 = f_n(M_1, M_2, M_0, \sim y, \sim m) = -40.2, -40.3, 69.5, 0.998, -1.727 \quad 1.737 \quad \text{Uniform}$$

Lateral Buckling Check M.b.Rd

$$L_e = 1.0 L = 1 \times 6.28 = 6.28 \text{ m}$$

$$M_{cr} = F_n(C_1, L_e, I_z, I_t, I_w, E) = 1.737, 6.280, 185.0, 11.7, 0.02030, 210000 = 55.550 \text{ kN.m}$$

$$\lambda_{LT} = \sqrt{W_{pl,y} / M_{cr}} = \sqrt{328 \times 275 / 55.55} = 1.274$$

$$C_{LT} = F_n(\lambda_{LT}, \Phi_{LT}, \beta, \lambda_{LT0}) = 1.274, 1.441, 0.750, 0.400 = 0.422 \quad \text{Curve d}$$

$$C_{LT,mod} = F_n(C_{LT}, \lambda_{LT}, k_c, f) = 0.422, 1.274, 0.759, 0.934 = 0.452 \quad 6.3.2.3$$

$$M_{b,Rd} = C \cdot W_{pl,y} \cdot f_y \leq M_{c,y,Rd} = 0.452 \times 328.0 \times 275 \leq 90.200 = 40.799 \text{ kN.m}$$

$$M_{y,Ed}/M_{b,Rd} = 40.316 / 40.799 = 0.988 \quad \text{OK}$$

Deflection Check - Load Case 2

$$l_{n-span} \delta \leq \text{Span}/360 \quad 8.14 \leq 6280 / 360 \quad 8.14 \text{ mm} \quad \text{OK}$$

STRUCTURAL CALCULATION



Hibbert Smith Consulting Ltd – Structural & Civil Engineers
T: 07949 171 787 W: www.HibbertSmith.com

Project Ref		P22-0006.128				Project Title		Generic Mobile Home Lifting								
Doc Ref		P22-0006-HSC-Ca-S-128				Doc Title		Generic Mobile Home Lifting Assessment								
Version No	Date	Aug 23	Calcs By:	RJS	Date	Aug 23	Check By:	RS	Date	Aug 23	Appr'd By:	RJS	Sheet No	60	Sheet Version	01

BEAM & BEAM-PORTION (MEMBER)

B-110: Span 2

Span 2 in Load Case 1

Member Loading and Member Forces

Loading Combination : 1 UT + 1.35 D1 + 1.5 L1

D1 UDLW	-000.320	(kN/m)
L1 PY	-016.250	0.530 (kN,m)
L1 PY	-016.250	2.350 (kN,m)
L1 PY	-016.250	4.180 (kN,m)
L1 PY	-016.250	6.000 (kN,m)

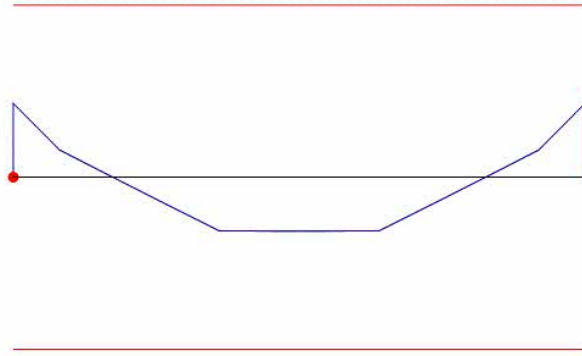

Member Forces in Load Case 1 and Maximum Deflection from Load Case 2

Span No.	Axial Force (kN)	Shear Force (kN)		Bending Moment (kNm)		Maximum Moment (kNm)	Maximum Deflection (mm @ m)
		End 1	End 2	Node 1	Node 2		
2	0.00C	50.16	-50.16	-41.97	-41.97	30.53 @ 3.265	9.38 @ 3.265

Classification and Effective Area (EN 1993: 2006)

Section (32.2 kg/m)	230x90 PFC 32.2 [Grade 43]		
Class = $F_n(b/T, d/t, f_y, N, M_y, M_z)$	6.43, 23.73, 275, 0, 41.97, 0	(Axial: Non-Slender)	Class 1

Auto Design Load Cases 1

Moment Capacity Check M.c.y.Rd

$V_{y,Ed}/V_{pl,y,Rd}$	50.16 / 294.203 =	0.17	Low Shear
$M_{c,y,Rd} = f_y \cdot W_{pl,y} / \gamma_{M0}$	275 x 355 / 1	97.625 kN.m	
$M_{y,Ed}/M_{c,y,Rd}$	-41.974 / 97.625 =	0.430	OK

Equivalent Uniform Moment Factor C1

$C_1 = f_n(M_1, M_2, M_0, \sim y, \sim m)$	-41.9, -41.9, 72.4, 1.000, -1.728	1.737	Uniform
--	-----------------------------------	-------	---------

Lateral Buckling Check M.b.Rd

$L_e = 1.0 L$	1 x 6.53 =	6.53 m	
$M_{cr} = F_n(C_1, L_e, I_z, I_t, I_w, E)$	1.737, 6.530, 334.0, 19.3, 0.02790, 210000	91.081 kN.m	
$\lambda_{LT} = \sqrt{W \cdot f_y / M_{cr}}$	$\sqrt{355 \times 275 / 91.081}$	1.035	
$CLT = F_n(\lambda_{LT}, \Phi_{LT}, \beta, \lambda_{LT0})$	1.035, 1.143, 0.750, 0.400	0.540	Curve d
$CLT.mod = F_n(CL_T, \lambda_{LT}, k_c, f)$	0.540, 1.035, 0.759, 0.893	0.605	6.3.2.3
$M_{b,Rd} = C \cdot W_{pl,y} \cdot f_y \leq M_{c,y,Rd}$	0.605 x 355.0 x 275 \leq 97.625 =	59.017 kN.m	
$M_{y,Ed}/M_{b,Rd}$	41.974 / 59.017	0.711	OK

Deflection Check - Load Case 2

In-span $\delta \leq \text{Span}/360$	9.38 \leq 6530 / 360	9.38 mm	OK
---------------------------------------	------------------------	---------	----

STRUCTURAL CALCULATION



Project Ref	P22-0006.128				Project Title	Generic Mobile Home Lifting											
Doc Ref	P22-0006-HSC-Ca-S-128				Doc Title	Generic Mobile Home Lifting Assessment											
Version No	01	Date	Aug 23	Calcs By:	RJS	Date	Aug 23	Check By:	RS	Date	Aug 23	Appr'd By:	RJS	Sheet No	61	Sheet Version	01

BEAM & BEAM-PORTION (MEMBER) B-111: Span 2 Span 2 in Load Case 1

Member Loading and Member Forces
Loading Combination : 1 UT + 1.35 D1 + 1.5 L1

D1 UDLW	-000.320	(kN/m)
L1 PY	-016.250 0.550	(kN,m)
L1 PY	-016.250 2.440	(kN,m)
L1 PY	-016.250 4.330	(kN,m)
L1 PY	-016.250 6.220	(kN,m)

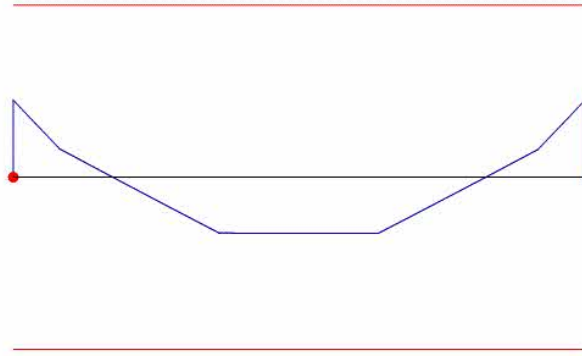

Member Forces in Load Case 1 and Maximum Deflection from Load Case 2

Span No.	Axial Force (kN)	Shear Force (kN)		Bending Moment (kNm)		Maximum Moment (kNm)	Maximum Deflection (mm @ m)
		End 1	End 2	Node 1	Node 2		
2	0.00C	50.28	-50.15	-43.69	-43.76	31.89 @ 3.537	10.54 @ 3.390

Classification and Effective Area (EN 1993: 2006)

Section (32.2 kg/m)	230x90 PFC 32.2 [Grade 43]		
Class = $F_n(b/T, d/t, f_y, N, M_y, M_z)$	6.43, 23.73, 275, 0, 43.76, 0	(Axial: Non-Slender)	Class 1
Auto Design Load Cases	1		

Shear Capacity Check

$V_{y,Ed}/V_{pl,y,Rd}$	50.275 / 294.203 =	0.171	OK
------------------------	--------------------	-------	----

Moment Capacity Check M.c.y.Rd

$V_{y,Ed}/V_{pl,y,Rd}$	50.154 / 294.203 =	0.17	Low Shear
$M_{c,y,Rd} = f_y \cdot W_{pl,y} / \gamma_{M0}$	275 x 355 / 1	97.625 kN.m	
$M_{y,Ed}/M_{c,y,Rd}$	-43.763 / 97.625 =	0.448	OK

Equivalent Uniform Moment Factor C1

$C_1 = f_n(M_1, M_2, M_0, \sim y, \sim m)$	-43.6, -43.7, 75.5, 0.998, -1.728	1.734	Uniform
--	-----------------------------------	-------	---------

Lateral Buckling Check M.b.Rd

$L_e = 1.0 L$	1 x 6.78 =	6.78 m	
$M_{cr} = F_n(C_1, L_e, I_z, I_t, I_w, E)$	1.734, 6.780, 334.0, 19.3, 0.02790, 210000	87.315 kN.m	
$\lambda_{LT} = \sqrt{W \cdot f_y / M_{cr}}$	$\sqrt{355 \times 275 / 87.315}$	1.057	
$C_{LT} = F_n(\lambda_{LT}, \Phi_{LT}, \beta, \lambda_{LT0})$	1.057, 1.169, 0.750, 0.400	0.527	Curve d
$C_{LT,mod} = F_n(C_{LT}, \lambda_{LT}, k_c, f)$	0.527, 1.057, 0.760, 0.896	0.589	6.3.2.3
$M_{b,Rd} = C \cdot W_{pl,y} \cdot f_y \leq M_{c,y,Rd}$	0.589 x 355.0 x 275 \leq 97.625 =	57.490 kN.m	
$M_{y,Ed}/M_{b,Rd}$	43.763 / 57.49	0.761	OK

Deflection Check - Load Case 2

In-span $\delta \leq \text{Span}/360$	10.54 \leq 6780 / 360	10.54 mm	OK
---------------------------------------	-------------------------	----------	----

STRUCTURAL CALCULATION



Hibbert Smith Consulting Ltd – Structural & Civil Engineers
T: 07949 171 787 W: www.HibbertSmith.com

Project Ref		P22-0006.128				Project Title		Generic Mobile Home Lifting								
Doc Ref		P22-0006-HSC-Ca-S-128				Doc Title		Generic Mobile Home Lifting Assessment								
Version No	Date	Aug 23	Calcs By:	RJS	Date	Aug 23	Check By:	RS	Date	Aug 23	Apprd By:	RJS	Sheet No	62	Sheet Version	01

BEAM & BEAM-PORTION (MEMBER)

C-104: Span 2

Span 2 in Load Case 1

Member Loading and Member Forces

Loading Combination : 1 UT + 1.35 D1 + 1.5 L1

D1 UDLW -000.178 (kN/m)
L1 PY -015.200 1.460 (kN,m)
L1 PY -015.200 3.310 (kN,m)



Member Forces in Load Case 1 and Maximum Deflection from Load Case 2

Span No.	Axial Force (kN)	Shear Force (kN)		Bending Moment (kNm)		Maximum Moment (kNm)	Maximum Deflection (mm @ m)
		End 1	End 2	Node 1	Node 2		
2	0.00C	23.43	-23.32	-19.91	-19.87	14.20 @ 2.589	10.23 @ 2.390

Classification and Effective Area (EN 1993: 2006)

Section (17.9 kg/m) 150x75 PFC 17.9 [Grade 43]
Class = $F_n(b/T, d/t, f_y, N, M_y, M_z)$ 7.5, 19.27, 275, 0, 19.91, 0 (Axial: Non-Slender) Class 1

Auto Design Load Cases 1

Moment Capacity Check M.c.y.Rd

$V_{y,Ed}/V_{pl,y,Rd}$ 23.43 / 151.627 = 0.155 Low Shear
 $M_{c,y,Rd} = f_y \cdot W_{pl,y} / \gamma_{M0}$ 275 x 132 / 1 36.3 kN.m
 $M_{y,Ed}/M_{c,y,Rd}$ -19.911 / 36.3 = 0.549 OK

Equivalent Uniform Moment Factor C1

$C_1 = f_n(M_1, M_2, M_0, -y, -m)$ -19.9, -19.9, 34.1, 0.998, -1.713 1.769 Uniform

Lateral Buckling Check M.b.Rd

$L_e = 1.0 L$ 1 x 4.78 = 4.78 m
 $M_{cr} = F_n(C_1, L_e, I_z, I_t, I_w, E)$ 1.769, 4.780, 131.0, 6.1, 0.004670, 210000 44.610 kN.m
 $\lambda_{LT} = \sqrt{W_{pl,y}/M_{cr}}$ $\sqrt{132 \times 275 / 44.61}$ 0.902
 $C_{LT} = F_n(\lambda_{LT}, \Phi_{LT}, \beta, \lambda_{LT0})$ 0.902, 0.996, 0.750, 0.400 0.620 Curve d
 $C_{LT,mod} = F_n(C_{LT}, \lambda_{LT}, k_c, f)$ 0.620, 0.902, 0.752, 0.878 0.705 6.3.2.3
 $M_{b,Rd} = C W_{pl,y} \cdot f_y \leq M_{c,y,Rd}$ 0.705 x 132.0 x 275 \leq 36.300 = 25.607 kN.m
 $M_{y,Ed}/M_{b,Rd}$ 19.911 / 25.607 0.778 OK

Deflection Check - Load Case 2

In-span $\delta \leq \text{Span}/360$ 10.23 \leq 4780 / 360 10.23 mm OK

STRUCTURAL CALCULATION



Hibbert Smith Consulting Ltd – Structural & Civil Engineers
T: 07949 171 787 W: www.HibbertSmith.com

Project Ref	P22-0006.128				Project Title	Generic Mobile Home Lifting											
Doc Ref	P22-0006-HSC-Ca-S-128				Doc Title	Generic Mobile Home Lifting Assessment											
Version No	01	Date	Aug 23	Calcs By:	RJS	Date	Aug 23	Check By:	RS	Date	Aug 23	Appr'd By:	RJS	Sheet No	63	Sheet Version	01

BEAM & BEAM-PORTION (MEMBER)

C-107: Span 2

Span 2 in Load Case 1

Member Loading and Member Forces

Loading Combination : 1 UT + 1.35 D1 + 1.5 L1

D1 UDLW -000.233 (kN/m)
L1 PY -015.200 0.970 (kN,m)
L1 PY -015.200 2.770 (kN,m)
L1 PY -015.200 4.560 (kN,m)

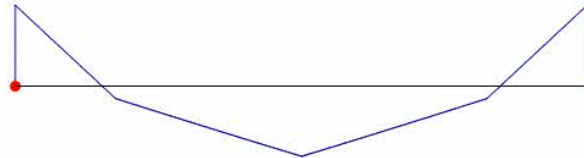

Member Forces in Load Case 1 and Maximum Deflection from Load Case 2

Span No.	Axial Force (kN)	Shear Force (kN)		Bending Moment (kNm)		Maximum Moment (kNm)	Maximum Deflection (mm @ m)
		End 1	End 2	Node 1	Node 2		
2	0.00C	35.04	-35.10	-29.39	-29.42	25.43 @ 2.770	8.34 @ 2.765

Classification and Effective Area (EN 1993: 2006)

Section (23.4 kg/m) 200x75 PFC 23.4 [Grade 43]
Class = $F_n(b/T, d/t, f_y, N, M_y, M_z)$ 6, 25.17, 275, 0, 29.42, 0 (Axial: Non-Slender) Class 1

Auto Design Load Cases 1

Moment Capacity Check M.c.y.Rd

$V_{y,Ed}/V_{pl,y,Rd}$ 35.096 / 212.754 = 0.165 Low Shear
 $M_{c,y,Rd} = f_y \cdot W_{pl,y} / \gamma_{M0}$ 275 x 227 / 1 62.425 kN.m
 $M_{y,Ed}/M_{c,y,Rd}$ -29.419 / 62.425 = 0.471 OK

Equivalent Uniform Moment Factor C1

$C_1 = f_n(M_1, M_2, M_0, -y, -m)$ -29.4, -29.4, 54.7, 0.999, -1.863 1.463 Uniform

Lateral Buckling Check M.b.Rd

$L_e = 1.0 L$ 1 x 5.53 = 5.53 m
 $M_{cr} = F_n(C_1, L_e, I_z, I_t, I_w, E)$ 1.463, 5.530, 170.0, 11.1, 0.01070, 210000 48.881 kN.m
 $\lambda_{LT} = \sqrt{W_{pl,y}/M_{cr}}$ $\sqrt{227 \times 275 / 48.881}$ 1.130
 $CLT = F_n(\lambda_{LT}, \Phi_{LT}, \beta, \lambda_{LT0})$ 1.130, 1.256, 0.750, 0.400 0.489 Curve d
 $CLT.mod = F_n(CL_T, \lambda_{LT}, k_c, f)$ 0.489, 1.130, 0.827, 0.932 0.525 6.3.2.3
 $M_{b,Rd} = C \cdot W_{pl,y} \cdot f_y \leq M_{c,y,Rd}$ 0.525 x 227.0 x 275 \leq 62.425 = 32.758 kN.m
 $M_{y,Ed}/M_{b,Rd}$ 29.419 / 32.758 0.898 OK

Deflection Check - Load Case 2

In-span $\delta \leq \text{Span}/360$ 8.34 \leq 5530 / 360 8.34 mm OK

STRUCTURAL CALCULATION



Project Ref		P22-0006.128			Project Title		Generic Mobile Home Lifting									
Doc Ref		P22-0006-HSC-Ca-S-128			Doc Title		Generic Mobile Home Lifting Assessment									
Version No	Date	Aug 23	Calcs By:	RJS	Date	Aug 23	Check By:	RS	Date	Aug 23	Appr'd By:	RJS	Sheet No	64	Sheet Version	01

BEAM & BEAM-PORTION (MEMBER) C-108: Span 2 Span 2 in Load Case 1

Member Loading and Member Forces
Loading Combination : 1 UT + 1.35 D1 + 1.5 L1

D1 UDLW	-000.255	(kN/m)
L1 PY	-015.200 0.500	(kN,m)
L1 PY	-015.200 2.180	(kN,m)
L1 PY	-015.200 3.850	(kN,m)
L1 PY	-015.200 5.530	(kN,m)

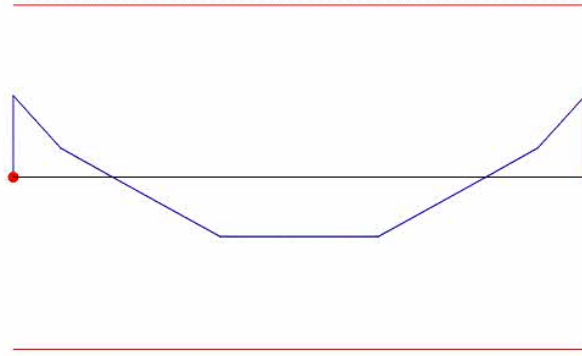

Member Forces in Load Case 1 and Maximum Deflection from Load Case 2

Span No.	Axial Force (kN)	Shear Force (kN)		Bending Moment (kNm)		Maximum Moment (kNm)	Maximum Deflection (mm @ m)
		End 1	End 2	Node 1	Node 2		
2	0.00C	46.64	-46.64	-36.24	-36.24	26.42 @ 3.015	8.91 @ 3.015

Classification and Effective Area (EN 1993: 2006)

Section (25.7 kg/m)	230x75 PFC 25.7 [Grade 43]		
Class = $F_n(b/T, d/t, f_y, N, M_y, M_z)$	6, 27.85, 275, 0, 36.25, 0	(Axial: Non-Slender)	Class 1

Auto Design Load Cases 1

Moment Capacity Check M.c.y.Rd

$V_{y,Ed}/V_{pl,y,Rd}$	46.638 / 258.202 =	0.181	Low Shear
$M_{c,y,Rd} = f_y \cdot W_{pl,y} / \gamma_{M0}$	275 x 278 / 1	76.45 kN.m	
$M_{y,Ed}/M_{c,y,Rd}$	-36.245 / 76.45 =	0.474	OK

Equivalent Uniform Moment Factor C1

$C_1 = f_n(M_1, M_2, M_0, -y, -m)$	-36.2, -36.2, 62.6, 1.000, -1.730	1.732	Uniform
------------------------------------	-----------------------------------	-------	---------

Lateral Buckling Check M.b.Rd

$L_e = 1.0 L$	1 x 6.03 =	6.03 m	
$M_{cr} = F_n(C_1, L_e, I_z, I_t, I_w, E)$	1.732, 6.030, 181.0, 11.8, 0.01530, 210000	56.755 kN.m	
$\lambda_{LT} = \sqrt{W_{pl,y}/M_{cr}}$	$\sqrt{278 \times 275 / 56.755}$	1.161	
$CLT = F_n(\lambda_{LT}, \Phi_{LT}, \beta, \lambda_{LT0})$	1.161, 1.294, 0.750, 0.400	0.474	Curve d
$CLT.mod = F_n(CLT, \lambda_{LT}, k_c, f)$	0.474, 1.161, 0.760, 0.911	0.520	6.3.2.3
$M_{b,Rd} = C \cdot W_{pl,y} \cdot f_y \leq M_{c,y,Rd}$	0.520 x 278.0 x 275 \leq 76.450 =	39.778 kN.m	
$M_{y,Ed}/M_{b,Rd}$	36.245 / 39.778	0.911	OK

Deflection Check - Load Case 2

In-span $\delta \leq \text{Span}/360$	8.91 \leq 6030 / 360	8.91 mm	OK
---------------------------------------	------------------------	---------	----

STRUCTURAL CALCULATION



Hibbert Smith Consulting Ltd – Structural & Civil Engineers
T: 07949 171 787 W: www.HibbertSmith.com

Project Ref	P22-0006.128				Project Title	Generic Mobile Home Lifting											
Doc Ref	P22-0006-HSC-Ca-S-128				Doc Title	Generic Mobile Home Lifting Assessment											
Version No	01	Date	Aug 23	Calcs By:	RJS	Date	Aug 23	Check By:	RS	Date	Aug 23	Appr'd By:	RJS	Sheet No	65	Sheet Version	01

BEAM & BEAM-PORION (MEMBER)

C-109: Span 1

Span 1 in Load Case 1

Member Loading and Member Forces

Loading Combination : 1 UT + 1.35 D1 + 1.5 L1

D1 UDLW -000.255 (kN/m)
L1 PY -015.200 0.150 (kN,m)
L1 PY -015.200 1.900 (kN,m)

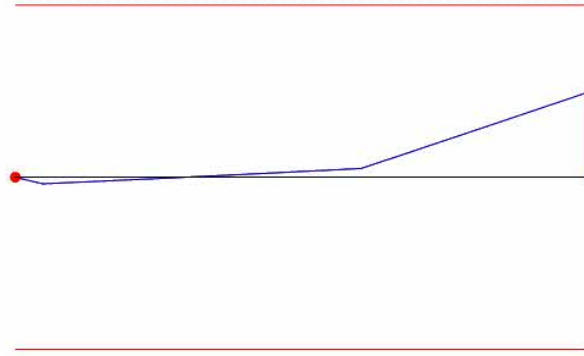

Member Forces in Load Case 1 and Maximum Deflection from Load Case 2

Span No.	Axial Force (kN)	Shear Force (kN)		Bending Moment (kNm)		Maximum Moment (kNm)	Maximum Deflection (mm @ m)
		End 1	End 2	Node 1	Node 2		
1	0.00C	19.27	-27.41	0.00	-37.64	2.89 @ 0.150	0.97 @ 2.257

Classification and Effective Area (EN 1993: 2006)

Section (25.7 kg/m) 230x75 PFC 25.7 [Grade 43]
Class = $F_n(b/T, d/t, f_y, N, M_y, M_z)$ 6, 27.85, 275, 0, 37.64, 0 (Axial: Non-Slender) Class 1

Auto Design Load Cases 1

Moment Capacity Check M.c.y.Rd

$V_{y,Ed}/V_{pl,y,Rd}$ 27.412 / 258.202 = 0.106 Low Shear
 $M_{c,y,Rd} = f_y \cdot W_{pl,y} / \gamma_{M0}$ 275 x 278 / 1 76.45 kNm
 $M_{y,Ed}/M_{c,y,Rd}$ -37.638 / 76.45 = 0.492 OK

Equivalent Uniform Moment Factor C1

$C_1 = f_n(M_1, M_2, M_0, \sim y, \sim m)$ 0.0, -37.6, 16.2, 0.000, -0.432 3.302 Uniform

Lateral Buckling Check M.b.Rd

$L_e = 1.0 L$ 1 x 3.14 = 3.14 m
 $M_{cr} = F_n(C_1, L_e, I_z, I_t, I_w, E)$ 3.302, 3.140, 181.0, 11.8, 0.01530, 210000 229.975 kNm
 $\lambda_{LT} = \sqrt{W_{pl,y}/M_{cr}}$ $\sqrt{278 \times 275 / 229.975}$ 0.577
 $C_{LT} = F_n(\lambda_{LT}, \Phi_{LT}, \beta, \lambda_{LT0})$ 0.577, 0.692, 0.750, 0.400 0.854 Curve d
 $C_{LT,mod} = F_n(C_{LT}, \lambda_{LT}, k_c, f)$ 0.854, 0.577, 0.550, 0.798 1.000
 $M_{b,Rd} = C W_{pl,y} \cdot f_y \leq M_{c,y,Rd}$ 1.000 x 278.0 x 275 \leq 76.450 = 76.450 kNm
 $M_{y,Ed}/M_{b,Rd}$ 37.638 / 76.45 0.492 OK

Deflection Check - Load Case 2

In-span $\delta \leq \text{Span}/360$ 0.97 \leq 3140 / 360 0.97 mm OK

STRUCTURAL CALCULATION



Hibbert Smith Consulting Ltd – Structural & Civil Engineers
T: 07949 171 787 W: www.HibbertSmith.com

Project Ref		P22-0006.128				Project Title		Generic Mobile Home Lifting								
Doc Ref		P22-0006-HSC-Ca-S-128				Doc Title		Generic Mobile Home Lifting Assessment								
Version No	Date	Aug 23	Calcs By:	RJS	Date	Aug 23	Check By:	RS	Date	Aug 23	Appr'd By:	RJS	Sheet No	66	Sheet Version	01

BEAM & BEAM-PORTION (MEMBER)

C-110: Span 2

Span 2 in Load Case 1

Member Loading and Member Forces

Loading Combination : 1 UT + 1.35 D1 + 1.5 L1

D1 UDLW -000.274	(kN/m)
L1 PY -015.200 0.530	(kN,m)
L1 PY -015.200 2.350	(kN,m)
L1 PY -015.200 4.180	(kN,m)
L1 PY -015.200 6.000	(kN,m)

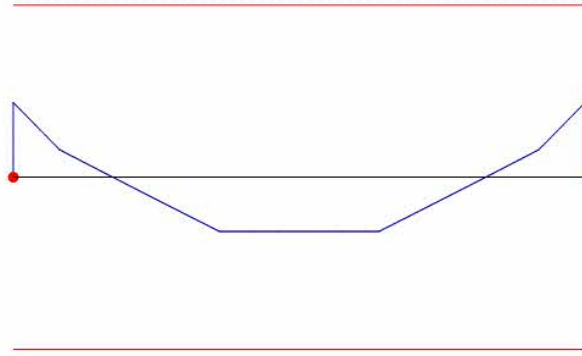

Member Forces in Load Case 1 and Maximum Deflection from Load Case 2

Span No.	Axial Force (kN)	Shear Force (kN)		Bending Moment (kNm)		Maximum Moment (kNm)	Maximum Deflection (mm @ m)
		End 1	End 2	Node 1	Node 2		
2	0.00C	46.81	-46.81	-39.16	-39.16	28.48 @ 3.265	8.53 @ 3.265

Classification and Effective Area (EN 1993: 2006)

Section (27.6 kg/m)	260x75 PFC 27.6 [Grade 43]		
Class = $F_n(b/T, d/t, f_y, N, M_y, M_z)$	6.25, 30.29, 275, 0, 39.16, 0	(Axial: Non-Slender)	Class 1

Auto Design Load Cases 1

Moment Capacity Check M.c.y.Rd

$V_{y.Ed}/V_{pl.y.Rd}$	46.808 / 307.699 =	0.152	Low Shear
$M_{c.y.Rd} = f_y \cdot W_{pl.y} / \gamma_{M0}$	275 x 328 / 1	90.2 kN.m	
$M_{y.Ed}/M_{c.y.Rd}$	-39.159 / 90.2 =	0.434	OK

Equivalent Uniform Moment Factor C1

$C_1 = f_n(M_1, M_2, M_0, -y, -m)$	-39.1, -39.1, 67.6, 1.000, -1.728	1.737	Uniform
------------------------------------	-----------------------------------	-------	---------

Lateral Buckling Check M.b.Rd

$L_e = 1.0 L$	1 x 6.53 =	6.53 m	
$M_{cr} = F_n(C_1, L_e, I_z, I_t, I_w, E)$	1.737, 6.530, 185.0, 11.7, 0.02030, 210000	53.210 kN.m	
$\lambda_{LT} = \sqrt{W_{pl.y}/M_{cr}}$	$\sqrt{328 \times 275 / 53.21}$	1.302	
$CLT = F_n(\lambda_{LT}, \Phi_{LT}, \beta, \lambda_{LT0})$	1.302, 1.478, 0.750, 0.400	0.411	Curve d
$CLT.mod = F_n(CL_T, \lambda_{LT}, k_c, f)$	0.411, 1.302, 0.759, 0.940	0.437	6.3.2.3
$M_{b.Rd} = C \cdot W_{pl.y} \cdot f_y \leq M_{c.y.Rd}$	0.437 x 328.0 x 275 \leq 90.200 =	39.405 kN.m	
$M_{y.Ed}/M_{b.Rd}$	39.159 / 39.405	0.994	OK

Deflection Check - Load Case 2

In-span $\delta \leq \text{Span}/360$	8.53 \leq 6530 / 360	8.53 mm	OK
---------------------------------------	------------------------	---------	----

STRUCTURAL CALCULATION



Project Ref	P22-0006.128				Project Title	Generic Mobile Home Lifting											
Doc Ref	P22-0006-HSC-Ca-S-128				Doc Title	Generic Mobile Home Lifting Assessment											
Version No	01	Date	Aug 23	Calcs By:	RJS	Date	Aug 23	Check By:	RS	Date	Aug 23	Apprd By:	RJS	Sheet No	67	Sheet Version	01

BEAM & BEAM-PORTION (MEMBER) C-111: Span 2 Span 2 in Load Case 1

Member Loading and Member Forces
Loading Combination : 1 UT + 1.35 D1 + 1.5 L1

D1 UDLW	-000.296	(kN/m)
L1 PY	-015.200 0.550	(kN,m)
L1 PY	-015.200 2.440	(kN,m)
L1 PY	-015.200 4.330	(kN,m)
L1 PY	-015.200 6.220	(kN,m)

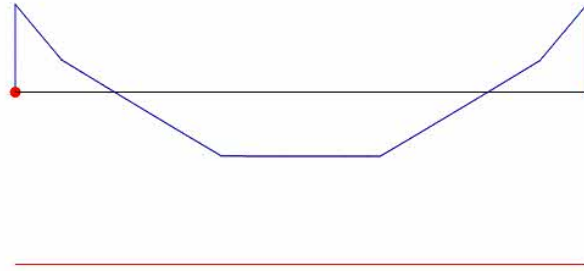

Member Forces in Load Case 1 and Maximum Deflection from Load Case 2

Span No.	Axial Force (kN)	Shear Force (kN)		Bending Moment (kNm)		Maximum Moment (kNm)	Maximum Deflection (mm @ m)
		End 1	End 2	Node 1	Node 2		
2	0.00C	47.01	-46.90	-40.85	-40.92	29.81 @ 3.537	13.75 @ 3.390

Classification and Effective Area (EN 1993: 2006)

Section (29.7 kg/m)	200x90 PFC 29.7 [Grade 43]		
Class = $f_n(b/t, d/t, f_y, N, M_y, M_z)$	6.43, 21.14, 275, 0, 40.92, 0	(Axial: Non-Slender)	Class 1
Auto Design Load Cases	1		

Shear Capacity Check

$V_{y.Ed}/V_{pl.y.Rd}$	47.012 / 243.873 =	0.193	OK
------------------------	--------------------	-------	----

Moment Capacity Check M.c.y.Rd

$V_{y.Ed}/V_{pl.y.Rd}$	46.898 / 243.873 =	0.192	Low Shear
$M_{c.y.Rd} = f_y \cdot W_{pl.y} / \gamma_{M0}$	275 x 291/1	80.025 kN.m	
$M_{y.Ed}/M_{c.y.Rd}$	-40.92 / 80.025 =	0.511	OK

Equivalent Uniform Moment Factor C1

$C_1 = f_n(M_1, M_2, M_0, \sim y, \sim m)$	-40.8, -40.9, 70.6, 0.998, -1.728	1.734	Uniform
--	-----------------------------------	-------	---------

Lateral Buckling Check M.b.Rd

$L_e = 1.0 L$	1 x 6.78 =	6.78 m	
$M_{cr} = F_n(C_1, L_e, I_z, I_t, I_w, E)$	1.734, 6.780, 314.0, 18.3, 0.01970, 210000	81.649 kN.m	
$\lambda_{LT} = \sqrt{W_{pl.y}/M_{cr}}$	$\sqrt{291 \times 275 / 81.649}$	0.990	
$CLT = F_n(\lambda_{LT}, \Phi_{LT}, \beta, \lambda_{LT0})$	0.990, 1.092, 0.750, 0.400	0.566	Curve d
$CLT.mod = F_n(CL_T, \lambda_{LT}, k_c, f)$	0.566, 0.990, 0.760, 0.888	0.637	6.3.2.3
$M_{b.Rd} = C W_{pl.y} \cdot f_y \leq M_{c.y.Rd}$	0.637 x 291.0 x 275 \leq 80.025 =	50.958 kN.m	
$M_{y.Ed}/M_{b.Rd}$	40.92 / 50.958	0.803	OK

Deflection Check - Load Case 2

In-span $\delta \leq \text{Span}/360$	13.75 \leq 6780 / 360	13.75 mm	OK
---------------------------------------	-------------------------	----------	----

STRUCTURAL CALCULATION



Project Ref	P22-0006.128				Project Title	Generic Mobile Home Lifting											
Doc Ref	P22-0006-HSC-Ca-S-128				Doc Title	Generic Mobile Home Lifting Assessment											
Version No	01	Date	Aug 23	Calcs By:	RJS	Date	Aug 23	Check By:	RS	Date	Aug 23	Appr'd By:	RJS	Sheet No	68	Sheet Version	01

Secondary Beams (Selected Cases)

BEAM & BEAM-PORION (MEMBER) A-305: Span 1 Span 1 in Load Case 1

Member Loading and Member Forces
Loading Combination : 1 UT + 1.35 D1 + 1.5 L1

D1 UDLW -000.400 (kN/m)
L1 PY -054.180 1.256 (kN,m)
L1 PY -054.180 3.769 (kN,m)

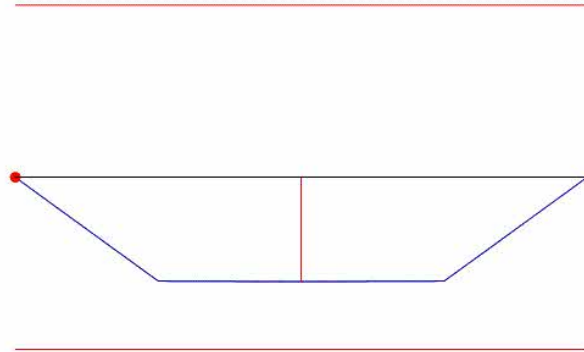

Member Forces in Load Case 1 and Maximum Deflection from Load Case 3

Span No.	Axial Force (kN)	Shear Force (kN)		Bending Moment (kNm)		Maximum Moment (kNm)	Maximum Deflection (mm @ m)
		End 1	End 2	Node 1	Node 2		
1	0.00C	82.63	-82.63	0.00	0.00	103.78 @ 2.513	11.21 @ 2.513

Classification and Effective Area (EN 1993: 2006)

Section (40.28 kg/m) 305x165 UB 40 [S 275]
Class = $F_n(b/T, d/t, f_y, N, M_y, M_z)$ 8.09, 44.2, 275, 0, 103.78, 0 (Axial: Non-Slender) Class 1

Auto Design Load Cases 1

Shear Capacity Check

$V_{y,Ed}/V_{pl,y,Rd}$ 82.632 / 318.775 = 0.259 OK

Moment Capacity Check M.c.y.Rd

$V_{y,Ed}/V_{pl,y,Rd}$ 0.001 / 318.775 = 0 Low Shear
 $M_{c,y,Rd} = f_y \cdot W_{pl,y} / \gamma_{M0}$ 275 x 623.1 / 1 171.353 kN.m
 $M_{y,Ed}/M_{c,y,Rd}$ 103.776 / 171.353 = 0.606 OK

Equivalent Uniform Moment Factor C1

$C_1 = f_n(M_1, M_2, M_0, \sim y, \sim m)$ 0.1, 0.1, 103.7, 0.964, 300.000 1.127 Uniform

Lateral Buckling Check M.b.Rd

$L_e = 1.0 L$ 1 x 5.025 = 5.025 m
 $M_{cr} = F_n(C_1, L_e, I_z, I_t, I_w, E)$ 1.127, 5.025, 766.0, 14.73, 0.1641, 210000 142.345 kN.m
 $\lambda_{LT} = \sqrt{W_{pl,y}/M_{cr}}$ $\sqrt{623.1 \times 275 / 142.345}$ 1.097
 $C_{LT} = F_n(\lambda_{LT}, \Phi_{LT}, \beta, \lambda_{LT0})$ 1.097, 1.070, 0.750, 0.400 0.640 Curve b
 $C_{LT,mod} = F_n(C_{LT}, \lambda_{LT}, k_c, f)$ 0.640, 1.097, 0.942, 0.976 0.656 6.3.2.3
 $M_{b,Rd} = C W_{pl,y} \cdot f_y \leq M_{c,y,Rd}$ 0.656 x 623.1 x 275 \leq 171.353 = 112.400 kN.m
 $M_{y,Ed}/M_{b,Rd}$ 103.777 / 112.4 0.923 OK

Deflection Check - Load Case 3

In-span $\delta \leq \text{Span}/360$ 11.21 \leq 5025 / 360 11.21 mm OK

STRUCTURAL CALCULATION



Hibbert Smith Consulting Ltd – Structural & Civil Engineers
T: 07949 171 787 W: www.HibbertSmith.com

Project Ref	P22-0006.128				Project Title	Generic Mobile Home Lifting											
Doc Ref	P22-0006-HSC-Ca-S-128				Doc Title	Generic Mobile Home Lifting Assessment											
Version No	01	Date	Aug 23	Calcs By:	RJS	Date	Aug 23	Check By:	RS	Date	Aug 23	Appr'd By:	RJS	Sheet No	69	Sheet Version	01

BEAM & BEAM-PORTION (MEMBER)

A-311: Span 1

Span 1 in Load Case 1

Member Loading and Member Forces

Loading Combination : 1 UT + 1.35 D1 + 1.5 L1

D1 UDLW -000.667 (kN/m)
L1 PY -070.460 1.694 (kN,m)
L1 PY -070.460 5.081 (kN,m)



Member Forces in Load Case 1 and Maximum Deflection from Load Case 3

Span No.	Axial Force (kN)	Shear Force (kN)		Bending Moment (kNm)		Maximum Moment (kNm)	Maximum Deflection (mm @ m)
		End 1	End 2	Node 1	Node 2		
1	0.00C	108.74	-108.74	0.00	0.00	184.21 @ 3.388	10.47 @ 3.388

Classification and Effective Area (EN 1993: 2006)

Section (67.12 kg/m) 457x191 UB 67 [S 275]
Class = $F_n(b/T, d/t, f_y, N, M_y, M_z)$ 7.48, 47.95, 275, 0, 184.21, 0 (Axial: Non-Slender) Class 1

Auto Design Load Cases 1

Shear Capacity Check

$V_{y,Ed}/V_{pl,y,Rd}$ 108.743 / 649.942 = 0.167 OK

Moment Capacity Check M.c.y.Rd

$V_{y,Ed}/V_{pl,y,Rd}$ 0 / 649.942 = 0 Low Shear

$M_{c,y,Rd} = f_y \cdot W_{pl,y} / \gamma_{M0}$ 275 x 1471/1 404.525 kN.m

$M_{y,Ed}/M_{c,y,Rd}$ 184.202 / 404.525 = 0.455 OK

Equivalent Uniform Moment Factor C1

$C_1 = f_n(M_1, M_2, M_0, \sim y, \sim m)$ 0.1, 0.1, 184.1, 0.939, 300.000 1.127 Uniform

Lateral Buckling Check M.b.Rd

$L_e = 1.0 L$ 1 x 6.775 = 6.775 m

$M_{cr} = F_n(C_1, L_e, I_z, I_t, I_w, E)$ 1.127, 6.775, 1455, 37.14, 0.7038, 210000 227.043 kN.m

$\lambda_{LT} = \sqrt{W \cdot f_y / M_{cr}}$ $\sqrt{1471 \times 275 / 227.043}$ 1.335

$C_{LT} = F_n(\lambda_{LT}, \Phi_{LT}, \beta, \lambda_{LT0})$ 1.335, 1.397, 0.750, 0.400 0.458 Curve c

$C_{LT,mod} = F_n(C_{LT}, \lambda_{LT}, k_c, f)$ 0.458, 1.335, 0.942, 0.988 0.464 6.3.2.3

$M_{b,Rd} = C \cdot W_{pl,y} \cdot f_y \leq M_{c,y,Rd}$ 0.464 x 1471 x 275 \leq 404.525 = 187.732 kN.m

$M_{y,Ed}/M_{b,Rd}$ 184.206 / 187.732 0.981 OK

Deflection Check - Load Case 3

In-span $\delta \leq \text{Span}/360$ 10.47 \leq 6775 / 360 10.47 mm OK

STRUCTURAL CALCULATION



Hibbert Smith Consulting Ltd – Structural & Civil Engineers
T: 07949 171 787 W: www.HibbertSmith.com

Project Ref	P22-0006.128				Project Title	Generic Mobile Home Lifting											
Doc Ref	P22-0006-HSC-Ca-S-128				Doc Title	Generic Mobile Home Lifting Assessment											
Version No	01	Date	Aug 23	Calcs By:	RJS	Date	Aug 23	Check By:	RS	Date	Aug 23	Appr'd By:	RJS	Sheet No	70	Sheet Version	01

BEAM & BEAM-PORION (MEMBER)

B-305: Span 1

Span 1 in Load Case 1

Member Loading and Member Forces

Loading Combination : 1 UT + 1.35 D1 + 1.5 L1

D1 UDLW -000.400 (kN/m)
L1 PY -056.010 1.256 (kN,m)
L1 PY -056.010 3.769 (kN,m)

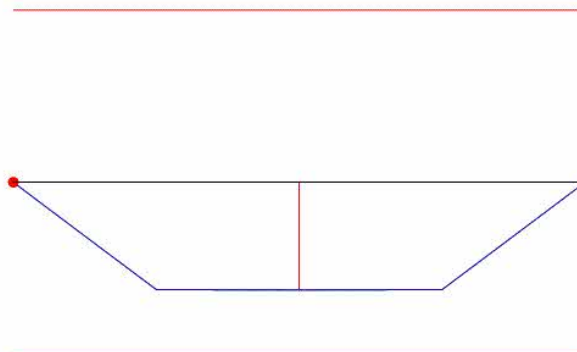

Member Forces in Load Case 1 and Maximum Deflection from Load Case 3

Span No.	Axial Force (kN)	Shear Force (kN)		Bending Moment (kNm)		Maximum Moment (kNm)	Maximum Deflection (mm @ m)
		End 1	End 2	Node 1	Node 2		
1	0.00C	85.37	-85.37	0.00	0.00	107.23 @ 2.513	11.58 @ 2.513

Classification and Effective Area (EN 1993: 2006)

Section (40.28 kg/m) 305x165 UB 40 [S 275]
Class = $F_n(b/T, d/t, f_y, N, M_y, M_z)$ 8.09, 44.2, 275, 0, 107.22, 0 (Axial: Non-Slender) Class 1
Auto Design Load Cases 1

Shear Capacity Check

$V_{y,Ed}/V_{pl,y,Rd}$ 85.377 / 318.775 = 0.268 OK

Moment Capacity Check M.c.y.Rd

$V_{y,Ed}/V_{pl,y,Rd}$ 0.001 / 318.775 = 0 Low Shear
 $M_{c,y,Rd} = f_y \cdot W_{pl,y} / \gamma_{M0}$ 275 x 623.1/1 171.353 kN.m
 $M_{y,Ed}/M_{c,y,Rd}$ 107.224 / 171.353 = 0.626 OK

Equivalent Uniform Moment Factor C1

$C_1 = f_n(M_1, M_2, M_0, \sim y, \sim m)$ 0.1, 0.1, 107.1, 0.988, 300.000 1.127 Uniform

Lateral Buckling Check M.b.Rd

$L_e = 1.0 L$ 1 x 5.025 = 5.025 m
 $M_{cr} = F_n(C_1, L_e, I_z, I_t, I_w, E)$ 1.127, 5.025, 766.0, 14.73, 0.1641, 210000 142.345 kN.m
 $\lambda_{LT} = \sqrt{W \cdot f_y / M_{cr}}$ $\sqrt{623.1 \times 275 / 142.345}$ 1.097
 $C_{LT} = F_n(\lambda_{LT}, \Phi_{LT}, \beta, \lambda_{LT0})$ 1.097, 1.070, 0.750, 0.400 0.640 Curve b
 $C_{LT,mod} = F_n(C_{LT}, \lambda_{LT}, k_c, f)$ 0.640, 1.097, 0.942, 0.976 0.656 6.3.2.3
 $M_{b,Rd} = C \cdot W_{pl,y} \cdot f_y \leq M_{c,y,Rd}$ 0.656 x 623.1 x 275 \leq 171.353 = 112.400 kN.m
 $M_{y,Ed}/M_{b,Rd}$ 107.224 / 112.4 0.954 OK

Deflection Check - Load Case 3

In-span $\delta \leq \text{Span}/360$ 11.58 \leq 5025 / 360 11.58 mm OK

STRUCTURAL CALCULATION



Hibbert Smith Consulting Ltd – Structural & Civil Engineers
T: 07949 171 787 W: www.HibbertSmith.com

Project Ref	P22-0006.128				Project Title	Generic Mobile Home Lifting											
Doc Ref	P22-0006-HSC-Ca-S-128				Doc Title	Generic Mobile Home Lifting Assessment											
Version No	01	Date	Aug 23	Calcs By:	RJS	Date	Aug 23	Check By:	RS	Date	Aug 23	Appr'd By:	RJS	Sheet No	71	Sheet Version	01

BEAM & BEAM-PORION (MEMBER)

B-311: Span 1

Span 1 in Load Case 1

Member Loading and Member Forces

Loading Combination : 1 UT + 1.35 D1 + 1.5 L1

D1 UDLW -000.737 (kN/m)
L1 PY -072.920 1.694 (kN,m)
L1 PY -072.920 5.081 (kN,m)



Member Forces in Load Case 1 and Maximum Deflection from Load Case 3

Span No.	Axial Force (kN)	Shear Force (kN)		Bending Moment (kNm)		Maximum Moment (kNm)	Maximum Deflection (mm @ m)
		End 1	End 2	Node 1	Node 2		
1	0.00C	112.75	-112.75	0.00	0.00	191.00 @ 3.388	11.68 @ 3.388

Classification and Effective Area (EN 1993: 2006)

Section (74.18 kg/m) 406x178 UB 74 [S 275]
Class = $F_n(b/T, d/t, f_y, N, M_y, M_z)$ 5.61, 37.94, 275, 0, 191, 0 (Axial: Non-Slender) Class 1
Auto Design Load Cases 1

Shear Capacity Check

$V_{y,Ed}/V_{pl,y,Rd}$ 112.756 / 664.363 = 0.170 OK

Moment Capacity Check M.c.y.Rd

$V_{y,Ed}/V_{pl,y,Rd}$ 0.001 / 664.363 = 0 Low Shear
 $M_{c,y,Rd} = f_y \cdot W_{pl,y} / \gamma_{M0}$ 275 x 1500.8/1 412.72 kN.m
 $M_{y,Ed}/M_{c,y,Rd}$ 190.991 / 412.72 = 0.463 OK

Equivalent Uniform Moment Factor C1

$C_1 = f_n(M_1, M_2, M_0, \sim y, \sim m)$ 0.1, 0.1, 190.9, 0.854, 300.000 1.127 Uniform

Lateral Buckling Check M.b.Rd

$L_e = 1.0 L$ 1 x 6.775 = 6.775 m
 $M_{cr} = F_n(C_1, L_e, I_z, I_t, I_w, E)$ 1.127, 6.775, 1548, 62.77, 0.6071, 210000 263.368 kN.m
 $\lambda_{LT} = \sqrt{W \cdot f_y / M_{cr}}$ $\sqrt{1500.8 \times 275 / 263.368}$ 1.252
 $C_{LT} = F_n(\lambda_{LT}, \Phi_{LT}, \beta, \lambda_{LT0})$ 1.252, 1.296, 0.750, 0.400 0.498 Curve c
 $C_{LT.mod} = F_n(C_{LT}, \lambda_{LT}, k_c, f)$ 0.498, 1.252, 0.942, 0.983 0.507 6.3.2.3
 $M_{b,Rd} = C \cdot W_{pl,y} \cdot f_y \leq M_{c,y,Rd}$ 0.507 x 1501 x 275 \leq 412.720 = 209.217 kN.m
 $M_{y,Ed}/M_{b,Rd}$ 191.002 / 209.217 0.913 OK

Deflection Check - Load Case 3

In-span $\delta \leq \text{Span}/360$ 11.68 \leq 6775 / 360 11.68 mm OK

STRUCTURAL CALCULATION



Project Ref	P22-0006.128				Project Title	Generic Mobile Home Lifting											
Doc Ref	P22-0006-HSC-Ca-S-128				Doc Title	Generic Mobile Home Lifting Assessment											
Version No	01	Date	Aug 23	Calcs By:	RJS	Date	Aug 23	Check By:	RS	Date	Aug 23	Appr'd By:	RJS	Sheet No	72	Sheet Version	01

BEAM & BEAM-PORTION (MEMBER) C-305: Span 1 Span 1 in Load Case 1

Member Loading and Member Forces
Loading Combination : 1 UT + 1.35 D1 + 1.5 L1

D1 UDLW -000.400 (kN/m)
L1 PY -057.390 1.256 (kN,m)
L1 PY -057.390 3.769 (kN,m)

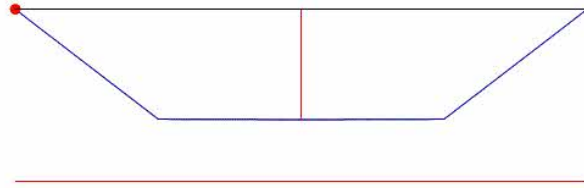

Member Forces in Load Case 1 and Maximum Deflection from Load Case 3

Span No.	Axial Force (kN)	Shear Force (kN)		Bending Moment (kNm)		Maximum Moment (kNm)	Maximum Deflection (mm @ m)
		End 1	End 2	Node 1	Node 2		
1	0.00C	87.44	-87.44	0.00	0.00	109.83 @ 2.513	11.86 @ 2.513

Classification and Effective Area (EN 1993: 2006)

Section (40.28 kg/m) 305x165 UB 40 [S 275]
Class = $F_n(b/T, d/t, f_y, N, M_y, M_z)$ 8.09, 44.2, 275, 0, 109.82, 0 (Axial: Non-Slender) Class 1
Auto Design Load Cases 1

Shear Capacity Check

$V_{y,Ed}/V_{pl,y,Rd}$ 87.447 / 318.775 = 0.274 OK

Moment Capacity Check M.c.y.Rd

$V_{y,Ed}/V_{pl,y,Rd}$ 0.001 / 318.775 = 0 Low Shear
 $M_{c,y,Rd} = f_y \cdot W_{pl,y} / \gamma_{M0}$ 275 x 623.1/1 171.353 kN.m
 $M_{y,Ed}/M_{c,y,Rd}$ 109.824 / 171.353 = 0.641 OK

Equivalent Uniform Moment Factor C1

$C_1 = f_n(M_1, M_2, M_0, \sim y, \sim m)$ 0.1, 0.1, 109.7, 0.989, 300.000 1.127 Uniform

Lateral Buckling Check M.b.Rd

$L_e = 1.0 L$ 1 x 5.025 = 5.025 m
 $M_{cr} = F_n(C_1, L_e, I_z, I_t, I_w, E)$ 1.127, 5.025, 766.0, 14.73, 0.1641, 210000 142.345 kN.m
 $\lambda_{LT} = \sqrt{W \cdot f_y / M_{cr}}$ $\sqrt{623.1 \times 275 / 142.345}$ 1.097
 $C_{LT} = F_n(\lambda_{LT}, \Phi_{LT}, \beta, \lambda_{LT0})$ 1.097, 1.070, 0.750, 0.400 0.640 Curve b
 $C_{LT,mod} = F_n(C_{LT}, \lambda_{LT}, k_c, f)$ 0.640, 1.097, 0.942, 0.976 0.656 6.3.2.3
 $M_{b,Rd} = C \cdot W_{pl,y} \cdot f_y \leq M_{c,y,Rd}$ 0.656 x 623.1 x 275 \leq 171.353 = 112.400 kN.m
 $M_{y,Ed}/M_{b,Rd}$ 109.824 / 112.4 0.977 OK

Deflection Check - Load Case 3

In-span $\delta \leq \text{Span}/360$ 11.86 \leq 5025 / 360 11.86 mm OK

STRUCTURAL CALCULATION



Project Ref	P22-0006.128				Project Title	Generic Mobile Home Lifting											
Doc Ref	P22-0006-HSC-Ca-S-128				Doc Title	Generic Mobile Home Lifting Assessment											
Version No	01	Date	Aug 23	Calcs By:	RJS	Date	Aug 23	Check By:	RS	Date	Aug 23	Appr'd By:	RJS	Sheet No	73	Sheet Version	01

BEAM & BEAM-PORTION (MEMBER) C-311: Span 1 Span 1 in Load Case 1

Member Loading and Member Forces
Loading Combination : 1 UT + 1.35 D1 + 1.5 L1

D1 UDLW -000.737 (kN/m)
L1 PY -074.780 1.694 (kN,m)
L1 PY -074.780 5.081 (kN,m)

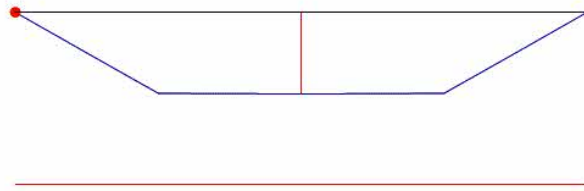

Member Forces in Load Case 1 and Maximum Deflection from Load Case 3

Span No.	Axial Force (kN)	Shear Force (kN)		Bending Moment (kNm)		Maximum Moment (kNm)	Maximum Deflection (mm @ m)
		End 1	End 2	Node 1	Node 2		
1	0.00C	115.54	-115.54	0.00	0.00	195.72 @ 3.388	11.97 @ 3.388

Classification and Effective Area (EN 1993: 2006)

Section (74.18 kg/m) 406x178 UB 74 [S 275]
Class = $F_n(b/T, d/t, f_y, N, M_y, M_z)$ 5.61, 37.94, 275, 0, 195.73, 0 (Axial: Non-Slender) Class 1
Auto Design Load Cases 1

Shear Capacity Check

$V_{y,Ed}/V_{pl,y,Rd}$ 115.546 / 664.363 = 0.174 OK

Moment Capacity Check M.c.y.Rd

$V_{y,Ed}/V_{pl,y,Rd}$ 0.001 / 664.363 = 0 Low Shear
 $M_{c,y,Rd} = f_y \cdot W_{pl,y} / \gamma_{M0}$ 275 x 1500.8/1 412.72 kN.m
 $M_{y,Ed}/M_{c,y,Rd}$ 195.718 / 412.72 = 0.474 OK

Equivalent Uniform Moment Factor C1

$C_1 = f_n(M_1, M_2, M_0, \sim y, \sim m)$ 0.1, 0.1, 195.6, 0.857, 300.000 1.127 Uniform

Lateral Buckling Check M.b.Rd

$L_e = 1.0 L$ 1 x 6.775 = 6.775 m
 $M_{cr} = F_n(C_1, L_e, I_z, I_t, I_w, E)$ 1.127, 6.775, 1548, 62.77, 0.6071, 210000 263.368 kN.m
 $\lambda_{LT} = \sqrt{W \cdot f_y / M_{cr}}$ $\sqrt{1500.8 \times 275 / 263.368}$ 1.252
 $C_{LT} = F_n(\lambda_{LT}, \Phi_{LT}, \beta, \lambda_{LT0})$ 1.252, 1.296, 0.750, 0.400 0.498 Curve c
 $C_{LT,mod} = F_n(C_{LT}, \lambda_{LT}, k_c, f)$ 0.498, 1.252, 0.942, 0.983 0.507 6.3.2.3
 $M_{b,Rd} = C \cdot W_{pl,y} \cdot f_y \leq M_{c,y,Rd}$ 0.507 x 1501 x 275 \leq 412.720 = 209.217 kN.m
 $M_{y,Ed}/M_{b,Rd}$ 195.728 / 209.217 0.936 OK

Deflection Check - Load Case 3

In-span $\delta \leq \text{Span}/360$ 11.97 \leq 6775 / 360 11.97 mm OK

STRUCTURAL CALCULATION



Hibbert Smith Consulting Ltd – Structural & Civil Engineers
T: 07949 171 787 W: www.HibbertSmith.com

Project Ref		P22-0006.128				Project Title		Generic Mobile Home Lifting								
Doc Ref		P22-0006-HSC-Ca-S-128				Doc Title		Generic Mobile Home Lifting Assessment								
Version No	Date	Aug 23	Calcs By:	RJS	Date	Aug 23	Check By:	RS	Date	Aug 23	Appr'd By:	RJS	Sheet No	74	Sheet Version	01

Primary Beams (Selected Cases)

BEAM & BEAM-PORION (MEMBER)

A-405: Span 1

Span 1 in Load Case 1

Member Loading and Member Forces

Loading Combination : 1 UT + 1.35 D1 + 1.5 L1

D1 UDLW -000.667 (kN/m)
L1 PY -054.180 1.900 (kN,m)
L1 PY -054.180 5.700 (kN,m)

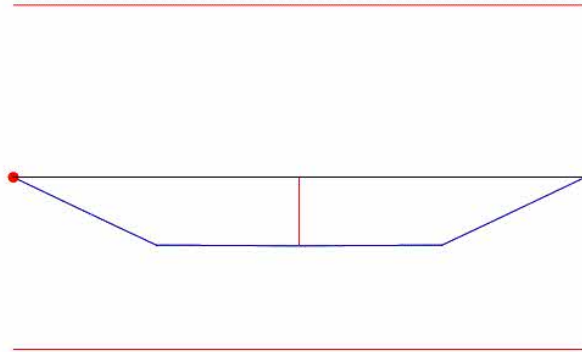

Member Forces in Load Case 1 and Maximum Deflection from Load Case 3

Span No.	Axial Force (kN)	Shear Force (kN)		Bending Moment (kNm)		Maximum Moment (kNm)	Maximum Deflection (mm @ m)
		End 1	End 2	Node 1	Node 2		
1	0.00C	84.69	-84.69	0.00	0.00	160.91 @ 3.800	11.51 @ 3.800

Classification and Effective Area (EN 1993: 2006)

Section (67.12 kg/m) 457x191 UB 67 [S 275]
Class = $F_n(b/T, d/t, f_y, N, M_y, M_z)$ 7.48, 47.95, 275, 0, 160.91, 0 (Axial: Non-Slender) Class 1

Auto Design Load Cases 1

Shear Capacity Check

$V_{y,Ed}/V_{pl,y,Rd}$ 84.695 / 649.942 = 0.130 OK

Moment Capacity Check M.c.y.Rd

$V_{y,Ed}/V_{pl,y,Rd}$ 0.001 / 649.942 = 0 Low Shear
 $M_{c,y,Rd} = f_y \cdot W_{pl,y} / \gamma_{M0}$ 275 x 1471/1 404.525 kN.m
 $M_{y,Ed}/M_{c,y,Rd}$ 160.91 / 404.525 = 0.398 OK

Equivalent Uniform Moment Factor C1

$C_1 = f_n(M_1, M_2, M_0, \sim y, \sim m)$ 0.1, 0.1, 160.8, 1.000, 300.000 1.127 Uniform

Lateral Buckling Check M.b.Rd

$L_e = 1.0 L$ 1 x 7.6 = 7.6 m
 $M_{cr} = F_n(C_1, L_e, I_z, I_t, I_w, E)$ 1.127, 7.600, 1455, 37.14, 0.7038, 210000 191.410 kN.m
 $\lambda_{LT} = \sqrt{W_{pl,y}/M_{cr}}$ $\sqrt{1471 \times 275 / 191.41}$ 1.454
 $C_{LT} = F_n(\lambda_{LT}, \Phi_{LT}, \beta, \lambda_{LT0})$ 1.454, 1.551, 0.750, 0.400 0.407 Curve c
 $C_{LT,mod} = F_n(C_{LT}, \lambda_{LT}, k_c, f)$ 0.407, 1.454, 0.942, 0.996 0.409 6.3.2.3
 $M_{b,Rd} = C \cdot W_{pl,y} \cdot f_y \leq M_{c,y,Rd}$ 0.409 x 1471 x 275 \leq 404.525 = 165.405 kN.m
 $M_{y,Ed}/M_{b,Rd}$ 160.91 / 165.405 0.973 OK

Deflection Check - Load Case 3

In-span $\delta \leq \text{Span}/360$ 11.51 \leq 7600 / 360 11.51 mm OK

STRUCTURAL CALCULATION



Hibbert Smith Consulting Ltd – Structural & Civil Engineers
T: 07949 171 787 W: www.HibbertSmith.com

Project Ref	P22-0006.128				Project Title	Generic Mobile Home Lifting											
Doc Ref	P22-0006-HSC-Ca-S-128				Doc Title	Generic Mobile Home Lifting Assessment											
Version No	01	Date	Aug 23	Calcs By:	RJS	Date	Aug 23	Check By:	RS	Date	Aug 23	Appr'd By:	RJS	Sheet No	75	Sheet Version	01

BEAM & BEAM-PORTION (MEMBER)

A-411: Span 1

Span 1 in Load Case 1

Member Loading and Member Forces

Loading Combination : 1 UT + 1.35 D1 + 1.5 L1

D1 UDLW -000.815 (kN/m)
L1 PY -070.460 1.900 (kN,m)
L1 PY -070.460 5.700 (kN,m)



Member Forces in Load Case 1 and Maximum Deflection from Load Case 3

Span No.	Axial Force (kN)	Shear Force (kN)		Bending Moment (kNm)		Maximum Moment (kNm)	Maximum Deflection (mm @ m)
		End 1	End 2	Node 1	Node 2		
1	0.00C	109.87	-109.87	0.00	0.00	208.75 @ 3.800	11.84 @ 3.800

Classification and Effective Area (EN 1993: 2006)

Section (82.02 kg/m) 457x191 UB 82 [S 275]
Class = $F_n(b/T, d/t, f_y, N, M_y, M_z)$ 5.98, 41.17, 275, 0, 208.75, 0 (Axial: Non-Slender) Class 1
Auto Design Load Cases 1

Shear Capacity Check

$V_{y,Ed}/V_{pl,y,Rd}$ 109.872 / 763.881 = 0.144 OK

Moment Capacity Check M.c.y.Rd

$V_{y,Ed}/V_{pl,y,Rd}$ 0 / 763.881 = 0 Low Shear
 $M_{c,y,Rd} = f_y \cdot W_{pl,y} / \gamma_{M0}$ 275 x 1831.3 / 1 503.608 kN.m
 $M_{y,Ed}/M_{c,y,Rd}$ 208.752 / 503.608 = 0.415 OK

Equivalent Uniform Moment Factor C1

$C_1 = f_n(M_1, M_2, M_0, \sim y, \sim m)$ 0.1, 0.1, 208.6, 0.991, 300.000 1.127 Uniform

Lateral Buckling Check M.b.Rd

$L_e = 1.0 L$ 1 x 7.6 = 7.6 m
 $M_{cr} = F_n(C_1, L_e, I_z, I_t, I_w, E)$ 1.127, 7.600, 1874, 69.21, 0.9201, 210000 275.559 kN.m
 $\lambda_{LT} = \sqrt{W \cdot f_y / M_{cr}}$ $\sqrt{1831.3 \times 275 / 275.559}$ 1.352
 $C_{LT} = F_n(\lambda_{LT}, \Phi_{LT}, \beta, \lambda_{LT0})$ 1.352, 1.419, 0.750, 0.400 0.451 Curve c
 $C_{LT,mod} = F_n(C_{LT}, \lambda_{LT}, k_c, f)$ 0.451, 1.352, 0.942, 0.989 0.456 6.3.2.3
 $M_{b,Rd} = C \cdot W_{pl,y} \cdot f_y \leq M_{c,y,Rd}$ 0.456 x 1831 x 275 \leq 503.608 = 229.498 kN.m
 $M_{y,Ed}/M_{b,Rd}$ 208.754 / 229.498 0.910 OK

Deflection Check - Load Case 3

In-span $\delta \leq \text{Span}/360$ 11.84 \leq 7600 / 360 11.84 mm OK

STRUCTURAL CALCULATION



Hibbert Smith Consulting Ltd – Structural & Civil Engineers
T: 07949 171 787 W: www.HibbertSmith.com

Project Ref	P22-0006.128				Project Title	Generic Mobile Home Lifting											
Doc Ref	P22-0006-HSC-Ca-S-128				Doc Title	Generic Mobile Home Lifting Assessment											
Version No	01	Date	Aug 23	Calcs By:	RJS	Date	Aug 23	Check By:	RS	Date	Aug 23	Appr'd By:	RJS	Sheet No	76	Sheet Version	01

BEAM & BEAM-PORTION (MEMBER)

B-405: Span 1

Span 1 in Load Case 1

Member Loading and Member Forces

Loading Combination : 1 UT + 1.35 D1 + 1.5 L1

D1 UDLW -000.815 (kN/m)
L1 PY -056.010 2.075 (kN,m)
L1 PY -056.010 6.225 (kN,m)



Member Forces in Load Case 1 and Maximum Deflection from Load Case 3

Span No.	Axial Force (kN)	Shear Force (kN)		Bending Moment (kNm)		Maximum Moment (kNm)	Maximum Deflection (mm @ m)
		End 1	End 2	Node 1	Node 2		
1	0.00C	88.58	-88.58	0.00	0.00	183.81 @ 4.150	12.44 @ 4.150

Classification and Effective Area (EN 1993: 2006)

Section (82.02 kg/m) 457x191 UB 82 [S 275]
Class = $F_n(b/T, d/t, f_y, N, M_y, M_z)$ 5.98, 41.17, 275, 0, 183.8, 0 (Axial: Non-Slender) Class 1
Auto Design Load Cases 1

Shear Capacity Check

$V_{y,Ed}/V_{pl,y,Rd}$ 88.583 / 763.881 = 0.116 OK

Moment Capacity Check M.c.y.Rd

$V_{y,Ed}/V_{pl,y,Rd}$ 0.001 / 763.881 = 0 Low Shear
 $M_{c,y,Rd} = f_y \cdot W_{pl,y} / \gamma_{M0}$ 275 x 1831.3 / 1 503.608 kN.m
 $M_{y,Ed}/M_{c,y,Rd}$ 183.803 / 503.608 = 0.365 OK

Equivalent Uniform Moment Factor C1

$C_1 = f_n(M_1, M_2, M_0, \sim y, \sim m)$ 0.1, 0.1, 183.7, 0.989, 300.000 1.127 Uniform

Lateral Buckling Check M.b.Rd

$L_e = 1.0 L$ 1 x 8.3 = 8.3 m
 $M_{cr} = F_n(C_1, L_e, I_z, I_t, I_w, E)$ 1.127, 8.300, 1874, 69.21, 0.9201, 210000 244.634 kN.m
 $\lambda_{LT} = \sqrt{W \cdot f_y / M_{cr}}$ $\sqrt{1831.3 \times 275 / 244.634}$ 1.435
 $CLT = F_n(\lambda_{LT}, \Phi_{LT}, \beta, \lambda_{LT0})$ 1.435, 1.526, 0.750, 0.400 0.415 Curve c
 $CLT.mod = F_n(CL_T, \lambda_{LT}, k_c, f)$ 0.415, 1.435, 0.942, 0.994 0.417 6.3.2.3
 $M_{b,Rd} = C \cdot W_{pl,y} \cdot f_y \leq M_{c,y,Rd}$ 0.417 x 1831 x 275 \leq 503.608 = 210.107 kN.m
 $M_{y,Ed}/M_{b,Rd}$ 183.803 / 210.107 0.875 OK

Deflection Check - Load Case 3

In-span $\delta \leq \text{Span}/360$ 12.44 \leq 8300 / 360 12.44 mm OK

STRUCTURAL CALCULATION



Project Ref	P22-0006.128				Project Title	Generic Mobile Home Lifting											
Doc Ref	P22-0006-HSC-Ca-S-128				Doc Title	Generic Mobile Home Lifting Assessment											
Version No	01	Date	Aug 23	Calcs By:	RJS	Date	Aug 23	Check By:	RS	Date	Aug 23	Appr'd By:	RJS	Sheet No	77	Sheet Version	01

BEAM & BEAM-PORTION (MEMBER)

B-411: Span 1

Span 1 in Load Case 1

Member Loading and Member Forces

Loading Combination : 1 UT + 1.35 D1 + 1.5 L1

D1 UDLW -000.887 (kN/m)
L1 PY -072.920 2.075 (kN,m)
L1 PY -072.920 6.225 (kN,m)



Member Forces in Load Case 1 and Maximum Deflection from Load Case 3

Span No.	Axial Force (kN)	Shear Force (kN)		Bending Moment (kNm)		Maximum Moment (kNm)	Maximum Deflection (mm @ m)
		End 1	End 2	Node 1	Node 2		
1	0.00C	114.35	-114.35	0.00	0.00	237.28 @ 4.150	14.50 @ 4.150

Classification and Effective Area (EN 1993: 2006)

Section (89.3 kg/m) 457x191 UB 89 [S 275]
Class = $F_n(b/T, d/t, f_y, N, M_y, M_z)$ 5.42, 38.82, 265, 0, 237.27, 0 (Axial: Non-Slender) Class 1
Auto Design Load Cases 1

Shear Capacity Check

$V_{y,Ed}/V_{pl,y,Rd}$ 114.352 / 784.828 = 0.146 OK

Moment Capacity Check M.c.y.Rd

$V_{y,Ed}/V_{pl,y,Rd}$ 0.001 / 784.828 = 0 Low Shear
 $M_{c,y,Rd} = f_y \cdot W_{pl,y} / \gamma_{M0}$ 265 x 2013.6/1 533.604 kN.m
 $M_{y,Ed}/M_{c,y,Rd}$ 237.271 / 533.604 = 0.445 OK

Equivalent Uniform Moment Factor C1

$C_1 = f_n(M_1, M_2, M_0, \sim y, \sim m)$ 0.1, 0.1, 237.2, 0.991, 300.000 1.127 Uniform

Lateral Buckling Check M.b.Rd

$L_e = 1.0 L$ 1 x 8.3 = 8.3 m
 $M_{cr} = F_n(C_1, L_e, I_z, I_t, I_w, E)$ 1.127, 8.300, 2092, 90.71, 1.035, 210000 288.929 kN.m
 $\lambda_{LT} = \sqrt{W \cdot f_y / M_{cr}}$ $\sqrt{2013.6 \times 265 / 288.929}$ 1.359
 $C_{LT} = F_n(\lambda_{LT}, \Phi_{LT}, \beta, \lambda_{LT0})$ 1.359, 1.428, 0.750, 0.400 0.447 Curve c
 $C_{LT,mod} = F_n(C_{LT}, \lambda_{LT}, k_c, f)$ 0.447, 1.359, 0.942, 0.989 0.452 6.3.2.3
 $M_{b,Rd} = C \cdot W_{pl,y} \cdot f_y \leq M_{c,y,Rd}$ 0.452 x 2014 x 265 \leq 533.604 = 241.333 kN.m
 $M_{y,Ed}/M_{b,Rd}$ 237.271 / 241.333 0.983 OK

Deflection Check - Load Case 3

In-span $\delta \leq \text{Span}/360$ 14.5 \leq 8300 / 360 14.5 mm OK

STRUCTURAL CALCULATION



Hibbert Smith Consulting Ltd – Structural & Civil Engineers
T: 07949 171 787 W: www.HibbertSmith.com

Project Ref	P22-0006.128				Project Title	Generic Mobile Home Lifting											
Doc Ref	P22-0006-HSC-Ca-S-128				Doc Title	Generic Mobile Home Lifting Assessment											
Version No	01	Date	Aug 23	Calcs By:	RJS	Date	Aug 23	Check By:	RS	Date	Aug 23	Appr'd By:	RJS	Sheet No	78	Sheet Version	01

BEAM & BEAM-PORITION (MEMBER)

C-405: Span 1

Span 1 in Load Case 1

Member Loading and Member Forces

Loading Combination : 1 UT + 1.35 D1 + 1.5 L1

D1 UDLW -000.737 (kN/m)
L1 PY -057.390 1.900 (kN,m)
L1 PY -057.390 5.700 (kN,m)

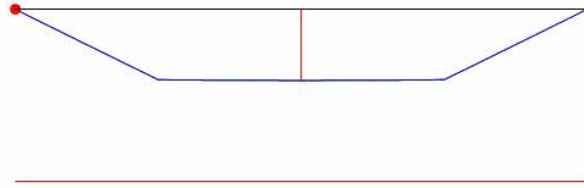

Member Forces in Load Case 1 and Maximum Deflection from Load Case 3

Span No.	Axial Force (kN)	Shear Force (kN)		Bending Moment (kNm)		Maximum Moment (kNm)	Maximum Deflection (mm @ m)
		End 1	End 2	Node 1	Node 2		
1	0.00C	89.87	-89.87	0.00	0.00	170.75 @ 3.800	13.14 @ 3.800

Classification and Effective Area (EN 1993: 2006)

Section (74.18 kg/m) 406x178 UB 74 [S 275]
Class = $F_n(b/T, d/t, f_y, N, M_y, M_z)$ 5.61, 37.94, 275, 0, 170.74, 0 (Axial: Non-Slender) Class 1
Auto Design Load Cases 1

Shear Capacity Check

$V_{y,Ed}/V_{pl,y,Rd}$ 89.873 / 664.363 = 0.135 OK

Moment Capacity Check M.c.y.Rd

$V_{y,Ed}/V_{pl,y,Rd}$ 0.001 / 664.363 = 0 Low Shear
 $M_{c,y,Rd} = f_y \cdot W_{pl,y} / \gamma_{M0}$ 275 x 1500.8/1 412.72 kN.m
 $M_{y,Ed}/M_{c,y,Rd}$ 170.737 / 412.72 = 0.414 OK

Equivalent Uniform Moment Factor C1

$C_1 = f_n(M_1, M_2, M_0, \sim y, \sim m)$ 0.1, 0.1, 170.6, 0.989, 300.000 1.127 Uniform

Lateral Buckling Check M.b.Rd

$L_e = 1.0 L$ 1 x 7.6 = 7.6 m
 $M_{cr} = F_n(C_1, L_e, I_z, I_t, I_w, E)$ 1.127, 7.600, 1548, 62.77, 0.6071, 210000 226.161 kN.m
 $\lambda_{LT} = \sqrt{W \cdot f_y / M_{cr}}$ $\sqrt{1500.8 \times 275 / 226.161}$ 1.351
 $CLT = F_n(\lambda_{LT}, \Phi_{LT}, \beta, \lambda_{LT0})$ 1.351, 1.417, 0.750, 0.400 0.451 Curve c
 $CLT.mod = F_n(CL_T, \lambda_{LT}, k_c, f)$ 0.451, 1.351, 0.942, 0.989 0.456 6.3.2.3
 $M_{b,Rd} = C \cdot W_{pl,y} \cdot f_y \leq M_{c,y,Rd}$ 0.456 x 1501 x 275 \leq 412.720 = 188.279 kN.m
 $M_{y,Ed}/M_{b,Rd}$ 170.738 / 188.279 0.907 OK

Deflection Check - Load Case 3

In-span $\delta \leq \text{Span}/360$ 13.14 \leq 7600 / 360 13.14 mm OK

STRUCTURAL CALCULATION



Hibbert Smith Consulting Ltd – Structural & Civil Engineers
T: 07949 171 787 W: www.HibbertSmith.com

Project Ref	P22-0006.128				Project Title	Generic Mobile Home Lifting											
Doc Ref	P22-0006-HSC-Ca-S-128				Doc Title	Generic Mobile Home Lifting Assessment											
Version No	01	Date	Aug 23	Calcs By:	RJS	Date	Aug 23	Check By:	RS	Date	Aug 23	Appr'd By:	RJS	Sheet No	79	Sheet Version	01

BEAM & BEAM-PORTION (MEMBER)

C-411: Span 1

Span 1 in Load Case 1

Member Loading and Member Forces

Loading Combination : 1 UT + 1.35 D1 + 1.5 L1

D1 UDLW -000.815 (kN/m)
L1 PY -074.780 1.900 (kN,m)
L1 PY -074.780 5.700 (kN,m)

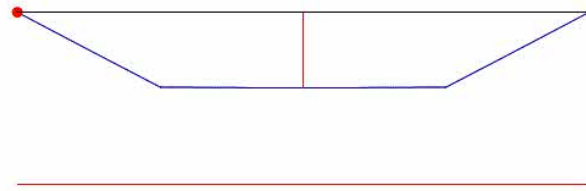

Member Forces in Load Case 1 and Maximum Deflection from Load Case 3

Span No.	Axial Force (kN)	Shear Force (kN)		Bending Moment (kNm)		Maximum Moment (kNm)	Maximum Deflection (mm @ m)
		End 1	End 2	Node 1	Node 2		
1	0.00C	116.35	-116.35	0.00	0.00	221.07 @ 3.800	12.54 @ 3.800

Classification and Effective Area (EN 1993: 2006)

Section (82.02 kg/m) 457x191 UB 82 [S 275]
Class = $F_n(b/T, d/t, f_y, N, M_y, M_z)$ 5.98, 41.17, 275, 0, 221.07, 0 (Axial: Non-Slender) Class 1
Auto Design Load Cases 1

Shear Capacity Check

$V_{y,Ed}/V_{pl,y,Rd}$ 116.352 / 763.881 = 0.152 OK

Moment Capacity Check M.c.y.Rd

$V_{y,Ed}/V_{pl,y,Rd}$ 0 / 763.881 = 0 Low Shear
 $M_{c,y,Rd} = f_y \cdot W_{pl,y} / \gamma_{M0}$ 275 x 1831.3 / 1 503.608 kN.m
 $M_{y,Ed}/M_{c,y,Rd}$ 221.064 / 503.608 = 0.439 OK

Equivalent Uniform Moment Factor C1

$C_1 = f_n(M_1, M_2, M_0, \sim y, \sim m)$ 0.1, 0.1, 221.0, 0.991, 300.000 1.127 Uniform

Lateral Buckling Check M.b.Rd

$L_e = 1.0 L$ 1 x 7.6 = 7.6 m
 $M_{cr} = F_n(C_1, L_e, I_z, I_t, I_w, E)$ 1.127, 7.600, 1874, 69.21, 0.9201, 210000 275.559 kN.m
 $\lambda_{LT} = \sqrt{W \cdot f_y / M_{cr}}$ $\sqrt{1831.3 \times 275 / 275.559}$ 1.352
 $C_{LT} = F_n(\lambda_{LT}, \Phi_{LT}, \beta, \lambda_{LT0})$ 1.352, 1.419, 0.750, 0.400 0.451 Curve c
 $C_{LT,mod} = F_n(C_{LT}, \lambda_{LT}, k_c, f)$ 0.451, 1.352, 0.942, 0.989 0.456 6.3.2.3
 $M_{b,Rd} = C \cdot W_{pl,y} \cdot f_y \leq M_{c,y,Rd}$ 0.456 x 1831 x 275 \leq 503.608 = 229.498 kN.m
 $M_{y,Ed}/M_{b,Rd}$ 221.066 / 229.498 0.963 OK

Deflection Check - Load Case 3

In-span $\delta \leq \text{Span}/360$ 12.54 \leq 7600 / 360 12.54 mm OK

STRUCTURAL CALCULATION



Hibbert Smith Consulting Ltd – Structural & Civil Engineers
T: 07949 171 787 W: www.HibbertSmith.com

Project Ref	P22-0006.128				Project Title	Generic Mobile Home Lifting											
Doc Ref	P22-0006-HSC-Ca-S-128				Doc Title	Generic Mobile Home Lifting Assessment											
Version No	01	Date	Aug 23	Calcs By:	RJS	Date	Aug 23	Check By:	RS	Date	Aug 23	Appr'd By:	RJS	Sheet No	80	Sheet Version	01

Constant Members

COLUMN - AXIAL WITH MOMENTS (MEMBER) Member SCL21d 3 @ Level 2 in Load Case 1

Member Loading and Member Forces

Loading Combination : 1 UT + 1.25 D1 + 1.5 L1

D1 D 077.010 (kN/m³)

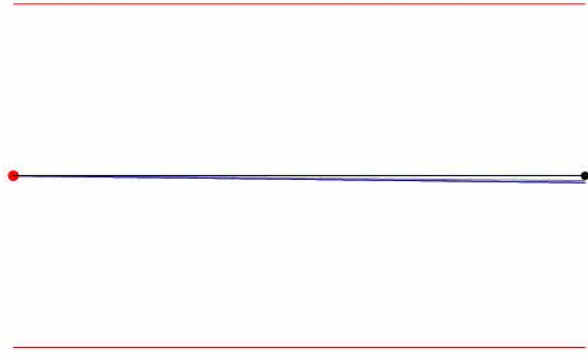

Member Forces in Load Case 1

Member No.	Node End 1 End 2	Axial Force (kN)	Shear Force (kN)	Bending Moment (kNm)	Maximum Moment (kNm)	Maximum Deflection (mm @ m)
1	3	71.484T	0.000	0.000	0.000	0.000
	6	73.032T	0.000	0.000	@ 0.000	@ 6.780

Additional Nominal Moments

M_{zUp} 1.791 kN.m

Classification and Effective Area (EN 1993: 2006)

Section (22.95 kg/m)

152x152 UC 23 [S 275]

Class = $F_n(b/T, d/t, f_y, N, M_y, M_z)$

11.19, 21.31, 275, 0, 0, 1.79

(Axial: Non-Slender)

Class 3

Effective Properties

Area=29.24 cm², $W_{pl,y}$ =179.39(182) cm³, $W_{pl,z}$ =76.18(80.2) cm³

Auto Design Load Cases

1-2

Local Capacity Check

$V_{z,Ed}/V_{pl,z,Rd}$

0 / 328.644 =

0

Low Shear

$M_{c,z,Rd} = f_y \cdot W_{el,z} / \gamma_{M0}$

275 x 52.67/1 =

14.484 kN.m

$N_{pl,Rd} = A_g \cdot f_y / \gamma_{M0}$

29.24x275/1 (No bearing / block tearing design)

804.1 kN

$N_{Ed}/N_{pl,Rd} + M_{y,Ed}/M_{c,y,Rd} + M_{z,Ed}/M_{c,z,Rd}$

-73.032 / 804.1 + 0 + 1.791 / 14.484 =

0.214

OK

Buckling Resistance

$U_{N,y} = N_{Ed}/(C_y \cdot N_{Rk}/\gamma_{M1})$

0 / 496.121

0.000

OK

$U_{N,z} = N_{Ed}/(C_z \cdot N_{Rk}/\gamma_{M1})$

0 / 204.811

0.000

OK

$U_{M,y} = M_{y,Ed}/(C_{LT} \cdot M_{y,Rk}/\gamma_{M1})$

0 / 29.009

0.000

OK

$U_{M,z} = M_{z,Ed}/(M_{z,Rk}/\gamma_{M1})$

1.791 / 14.484

0.124

OK

$k_y y = C_{my} \{1 + 0.6 \lambda_y U_{N,y}\}$

1.000

1.000

$k_z z = C_{mz} \{1 + 0.6 U_{N,z}\}$

0.600

0.600

$k_y z = k_z z$

0.600

0.600

$k_z y = 1 - \{0.05 \lambda_z / (C_{mLT} - 0.25)\} U_{N,z}$

0.000 + 1.000x0.000 + 0.600x0.124

0.074

OK

$U_{Nz} + k_z y \cdot U_{M,y} + k_y z \cdot U_{M,z}$

0.000 + 1.000x0.000 + 0.600x0.124

0.074

OK

Deflection Check In-Span - Load Case 0

$\delta \leq \text{Span}/360$

0 \leq 5500 / 360

0 mm

OK

Deflection Check Lateral Sway - Load Case 3

$\delta \leq \text{Span}/200$

0.09 \leq 5500 / 200

0.09 mm

OK

STRUCTURAL CALCULATION



Project Ref	P22-0006.128				Project Title	Generic Mobile Home Lifting											
Doc Ref	P22-0006-HSC-Ca-S-128				Doc Title	Generic Mobile Home Lifting Assessment											
Version No	01	Date	Aug 23	Calcs By:	RJS	Date	Aug 23	Check By:	RS	Date	Aug 23	Appr'd By:	RJS	Sheet No	81	Sheet Version	01

EDGE TIE - AXIAL WITH MOMENTS (MEMBER) Member SBL2Id 4 @ Level 2 in Load Case 2

Member Loading and Member Forces

Loading Combination : 1 UT + 1.35 D1 + 1.05 L1

D1 D 077.010 (kN/m³)



Member Forces in Load Case 2

Member No.	Node End 1 End 2	Axial Force (kN)	Shear Force (kN)	Bending Moment (kNm)	Maximum Moment (kNm)	Maximum Deflection (mm @ m)
2	5	6.302T	0.716	0.000	1.213	0.000
	6	6.302T	-0.716	0.000	@ 3.322	@ 6.780

Classification and Effective Area (EN 1993: 2006)

Section (15.95 kg/m) 152x89 UB 16 [S 275]
 Class = $F_n(b/T, d/t, f_y, N, M_y, M_z)$ 5.76, 27.07, 275, 0, 1.21, 0 (Axial: Non-Slender) Class 1

Auto Design Load Cases 1-2

Shear Capacity Check

$V_{y,Ed}/V_{pl,y,Rd}$ 0.718 / 129.829 = 0.006 OK

Local Capacity Check

$V_{y,Ed}/V_{pl,y,Rd}$ 0.001 / 129.829 = 0 Low Shear
 $M_{c,y,Rd} = f_y \cdot W_{pl,y} / \gamma_{M0}$ 275 x 123.3/1 33.908 kN.m
 $N_{pl,Rd} = A_g \cdot f_y / \gamma_{M0}$ 20.32x275/1 (No bearing / block tearing design) 558.8 kN
 $n = N_{Ed}/N_{pl,Rd}$ -6.302 / 558.8 = 0.011 OK
 $W_{pl,N,y} = F_n(W_{pl,y}, A_{vy},)$ 123.3, 8.177, 0.011 123.3 cm³
 $M_{N,y,Rd} = W_{pl,N,y} \cdot f_y / \gamma_{M0}$ 123.3 x 275/1 33.908 kN.m
 $(M_{y,Ed}/M_{N,y,Rd} + (M_{z,Ed}/M_{N,z,Rd}))^2 + (0)^1 = 0.001$ OK

Equivalent Uniform Moment Factors C1, C.mLT, C.mz, and C.my

$C_1 = f_n(M_1, M_2, M_0, \sim y, \sim m)$ 0.0, 0.0, 1.2, 0.000, 300.000 1.127 Uniform
 $C_{mLT} = 0.95 + 0.05a_h$ $M_h = 0, M_s = 1.21, \sim y = 1.000, a_s = 0.000$ 0.95 Table B.3
 $C_{mz} = \text{Max}(0.6 + 0.4 \sim y, 0.4)$ $M = 0, \sim y = 1.000$ 1 Table B.3
 $C_{my} = 0.95 + 0.05a_h$ $M_h = 0, M_s = 1.21, \sim y = 1.000, a_s = 0.000$ 0.95 Table B.3

Lateral Buckling Check M.b.Rd

$L_e = 1.00 L$ 1 x 6.78 = 6.78 m
 $M_{cr} = F_n(C_1, L_e, I_z, I_t, I_w, E)$ 1.127, 6.780, 90.6, 3.561, 0.004688, 210000 12.656 kN.m
 $\lambda_{LT} = \sqrt{W_{pl,y}/M_{cr}}$ $\sqrt{123.3 \times 275 / 12.656}$ 1.637
 $C_{LT} = F_n(\lambda_{LT}, \Phi_{LT}, \beta, \lambda_{LT0})$ 1.637, 1.715, 0.750, 0.400 0.373 Curve b
 $C_{LT,mod} = F_n(C_{LT}, \lambda_{LT}, k_c, f)$ 0.373, 1.637, 0.942, 1.000 0.373 6.3.2.3
 $M_{b,Rd} = C W_{pl,y} \cdot f_y \leq M_{c,y,Rd}$ 0.373 x 123.3 x 275 \leq 33.908 = 12.651 kN.m

Buckling Resistance

$U_{N,y} = N_{Ed}/(C_y \cdot N_{Rk}/\gamma_{M1})$ 0 / 289.746 0.000 OK
 $U_{N,z} = N_{Ed}/(C_z \cdot N_{Rk}/\gamma_{M1})$ 0 / 37.315 0.000 OK
 $U_{M,y} = M_{y,Ed}/(C_{LT} \cdot M_{y,Rk}/\gamma_{M1})$ 1.212 / 12.651 0.096 OK
 $U_{M,z} = M_{z,Ed}/(M_{z,Rk}/\gamma_{M1})$ 0 / 8.58 0.000 OK
 $k_y y = C_{my} \{1 + 0.8 U_{N,y}\}$ 0.950
 $k_z z = C_{mz} \{1 + 1.4 U_{N,z}\}$ 1.000
 $k_y z = 0.6 k_z z$ 0.600
 $k_z y = 1 - \{0.1 \lambda_z / (C_{mLT} - 0.25)\} U_{N,z}$ 1.000
 $U_{Ny} + k_y y \cdot U_{M,y} + k_y z \cdot U_{M,z}$ 0.000 + 0.950 x 0.096 + 0.600 x 0.000 0.091 OK
 $U_{Nz} + k_z y \cdot U_{M,y} + k_z z \cdot U_{M,z}$ 0.000 + 1.000 x 0.096 + 1.000 x 0.000 0.096 OK

STRUCTURAL CALCULATION



Hibbert Smith Consulting Ltd – Structural & Civil Engineers
T: 07949 171 787 W: www.HibbertSmith.com

Project Ref	P22-0006.128				Project Title	Generic Mobile Home Lifting											
Doc Ref	P22-0006-HSC-Ca-S-128				Doc Title	Generic Mobile Home Lifting Assessment											
Version No	01	Date	Aug 23	Calcs By:	RJS	Date	Aug 23	Check By:	RS	Date	Aug 23	Appr'd By:	RJS	Sheet No	82	Sheet Version	01

CROSS BRACE - STRUT AND TIE (MEMBER)

Member SBRL2Id 7 @ Level 2

Classification and Effective Area (EN 1993: 2006)

Section (4.71 kg/m)	75x8 Flat 4.71 [S 275]		
Class = $F_n(b/t, f_y)$	9.38, 275	(Axial: Non-Slender)	Class 1

Auto Design Load Cases 1-2

Axially Loaded Member in Tension : 6.2.3 (Case 1)

$T_c = A_g \cdot f_y / \gamma_{M0}$	6x275/1 (No bearing / block tearing design)	165 kN	
F (Tie)/ T_c	5.914 / 165	0.036	OK

BEAM & BEAM-PORION (MEMBER)

DIAGONAL BRACE - STRUT AND TIE (MEMBER)

Member SBL2Id 5 @ Level 2

Classification and Effective Area (EN 1993: 2006)

Section (3.97 kg/m)	48.3x3.6 CHS 3.97 [S 275]		
Class = $F_n(D/t, f_y)$	13.42, 275	(Axial: Non-Slender)	Class 1

Auto Design Load Cases 1-2

Axially Loaded Member in Tension : 6.2.3 (Case 1)

$T_c = A_g \cdot f_y / \gamma_{M0}$	5.06x275/1 (No bearing / block tearing design)	139.15 kN	
F (Tie)/ T_c	25.927 / 139.15	0.186	OK

STRUCTURAL CALCULATION



Project Ref	P22-0006.128				Project Title	Generic Mobile Home Lifting											
Doc Ref	P22-0006-HSC-Ca-S-128				Doc Title	Generic Mobile Home Lifting Assessment											
Version No	01	Date	Aug 23	Calcs By:	RJS	Date	Aug 23	Check By:	RS	Date	Aug 23	Appr'd By:	RJS	Sheet No	83	Sheet Version	01

STRUT BEAM- AXIAL WITH MOMENTS (MEMBER)

Member SB 4-15\K-GL2Id 70 @ Level Roof in Load Case 1 :
Design group 11

Member Loading and Member Forces
Loading Combination : 1 UT + 1.5 D1

D1 D 077.010 (kN/m³)



Member Forces in Load Case 1 and Maximum Deflection from Load Case 2

Member No.	Node End 1 End 2	Axial Force (kN)	Torque Moment (kNm)	Shear Force (kN)		Bending Moment (kNm)		Maximum Moment (kNm @ m)		Max Def (mm @ m)
				y-y	z-z	y-y	z-z	y-y	z-z	
2	130	233.42C	0.00	0.77	0.00	0.00	0.00	0.79	0.00	0.24
	136	233.42C	0.00	-0.77	0.00	0.00	0.00	@ 2.034	@ 0.000	@ 2.075

Classification and Effective Area (EN 1993: 2006)

Section (25.09 kg/m) 203x133 UB 25 [S 275]
Class = $F_n(b/T, d/t, f_y, N, M_y, M_z)$ 8.54, 30.25, 275, 233.42, 0.79, 0 (Axial: Non-Slender) Class 1

Auto Design Load Cases 1

Shear Capacity Check

$V_{y.Ed}/V_{pl.y.Rd}$ 0.767 / 203.402 = 0.004 OK

Local Capacity Check

$V_{y.Ed}/V_{pl.y.Rd}$ 0 / 203.402 = 0 Low Shear
 $M_{c.y.Rd} = f_y \cdot W_{pl.y} / \gamma_{M0}$ 275 x 257.7/1 70.868 kN.m
 $N_{pl.Rd} = A_g \cdot f_y / \gamma_{M0}$ 31.96 x 275/1 = 878.9 kN
 $n = N_{Ed}/N_{pl.Rd}$ 233.422 / 878.9 = 0.266 OK
 $W_{pl.N.y} = F_n(W_{pl.y}, A_{vy})$ 257.7, 12.811, 0.266 229.38 cm³
 $M_{N.y.Rd} = W_{pl.N.y} \cdot f_y / \gamma_{M0}$ 229.38 x 275/1 63.08 kN.m
 $(M_{y.Ed}/M_{N.y.Rd} + (M_{z.Ed}/M_{N.z.Rd}))^2 + (0)^{1.328} = 0$ OK

Compression Resistance N.b.Rd

$L_{ey} = K_y \cdot L_y$ 1x4.15 = 4.15
 $\lambda_y = \sqrt{A \cdot f_y / N_{cr}}$ $\sqrt{31.96 \times 275 / 2817.36}$ 0.558
 $N_{b.y.Rd} = Area \cdot c \cdot f_y / \gamma_{M1}$ 31.96x0.905x275/10/1 = 795.474 kN Curve a
 $L_{ez} = K_z \cdot L_z$ 1x4.15 = 4.15
 $\lambda_z = \sqrt{A \cdot f_y / N_{crz}}$ $\sqrt{31.96 \times 275 / 371.26}$ 1.537
 $N_{b.z.Rd} = Area \cdot c \cdot f_y / \gamma_{M1}$ 31.96x0.329x275/10/1 = 289.108 kN Curve b
 $L_{et} = K_t \cdot L_x$ 1x4.15 = 4.15
 $\lambda_T = \sqrt{A \cdot f_y / N_{crT}}$ $\sqrt{31.96 \times 275 / 1006.25}$ 0.935
 $N_{b.T.Rd} = Area \cdot c \cdot f_y / \gamma_{M1}$ 31.96x0.639x275/10/1 = 561.547 kN Curve b

Equivalent Uniform Moment Factors C1, C.mLT, C.mz, and C.my

$C_1 = f_n(M_1, M_2, M_o, \sim y, \sim m)$ 0.0, 0.0, 0.8, 0.000, 300.000 1.127 Uniform
 $C_{mLT} = 0.95 + 0.05a_h$ $M_h = 0, M_s = 0.79, \sim y = 0.000, a_s = 0.001$ 0.95 Table B.3
 $C_{mz} = \text{Max}(0.6 + 0.4 \sim y, 0.4)$ $M = 0, \sim y = 1.000$ 1 Table B.3
 $C_{my} = 0.95 + 0.05a_h$ $M_h = 0, M_s = 0.79, \sim y = 1.000, a_s = 0.000$ 0.95 Table B.3

Lateral Buckling Check M.b.Rd

$L_e = 1.00 L$ 1 x 4.15 = 4.15 m
 $M_{cr} = F_n(C_1, L_e, I_z, I_t, I_w, E)$ 1.127, 4.150, 308.5, 5.964, 0.02933, 210000 62.735 kN.m
 $\lambda_{LT} = \sqrt{W \cdot f_y / M_{cr}}$ $\sqrt{257.7 \times 275 / 62.735}$ 1.063
 $C_{LT} = F_n(\lambda_{LT}, \Phi_{LT}, \beta, \lambda_{LT0})$ 1.063, 1.036, 0.750, 0.400 0.661 Curve b
 $C_{LT.mod} = F_n(C_{LT}, \lambda_{LT}, K_c, f)$ 0.661, 1.063, 0.942, 0.975 0.678 6.3.2.3
 $M_{b.Rd} = C \cdot W_{pl.y} \cdot f_y \leq M_{c.y.Rd}$ 0.678 x 257.7 x 275 \leq 70.868 = 48.059 kN.m

STRUCTURAL CALCULATION



Hibbert Smith Consulting Ltd – Structural & Civil Engineers
T: 07949 171 787 W: www.HibbertSmith.com

Project Ref		P22-0006.128				Project Title		Generic Mobile Home Lifting							
Doc Ref		P22-0006-HSC-Ca-S-128				Doc Title		Generic Mobile Home Lifting Assessment							
Version No	Date	Calcs By:			Date	Check By:			Date	Appr'd By:	Sheet No	Sheet Version			
01	Aug 23	RJS			Aug 23	RS			Aug 23	RJS	84			01	

Buckling Resistance

$U_{N,y} = N_{Ed} / (C_y \cdot N_{Rk} / \gamma_{M1})$	233.422 / 795.474	0.293	OK
$U_{N,z} = N_{Ed} / (C_z \cdot N_{Rk} / \gamma_{M1})$	233.422 / 289.108	0.807	OK
$U_{M,y} = M_{y,Ed} / (C_{LT} \cdot M_{y,Rk} / \gamma_{M1})$	0.794 / 48.059	0.017	OK
$U_{M,z} = M_{z,Ed} / (M_{z,Rk} / \gamma_{M1})$	0 / 19.498	0.000	OK
$k_y y = C_{my} \{1 + (\lambda_y - 0.2) U_{N,y}\}$		1.050	
$k_z z = C_{mz} \{1 + 1.4 U_{N,z}\}$		2.130	
$k_y z = 0.6 k_z z$		1.278	
$k_z y = 1 - \{0.1 \lambda_z / (C_{mLT} - 0.25)\} U_{N,z}$		0.823	
$U_{Ny} + k_y y \cdot U_{My} + k_y z \cdot U_{Mz}$	0.293 + 1.050 x 0.017 + 1.278 x 0.000	0.311	OK
$U_{Nz} + k_z y \cdot U_{My} + k_z z \cdot U_{Mz}$	0.807 + 0.823 x 0.017 + 2.130 x 0.000	0.821	OK

Deflection Check - Load Case 2

In-span $\delta \leq \text{Span}/360$	$0.24 \leq 4150 / 360$	0.24 mm	OK
---------------------------------------	------------------------	---------	----

STRUCTURAL CALCULATION



Project Ref	P22-0006.128				Project Title	Generic Mobile Home Lifting											
Doc Ref	P22-0006-HSC-Ca-S-128				Doc Title	Generic Mobile Home Lifting Assessment											
Version No	01	Date	Aug 23	Calcs By:	RJS	Date	Aug 23	Check By:	RS	Date	Aug 23	Appr'd By:	RJS	Sheet No	85	Sheet Version	01

NEEDLE TIE - AXIAL WITH MOMENTS (MEMBER) Member SB G\9-10L1Id 59 @ Level Grd in Load Case 1 :

Member Loading and Member Forces
Loading Combination : 1 UT + 1.5 D1

D1 D 077.010 (kN/m³)
D1 PTRY -001.141 0.300 0.599 -001.141

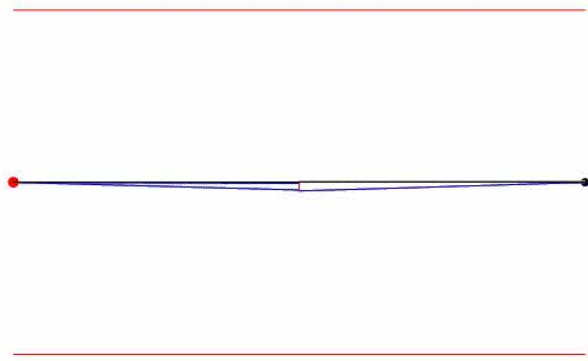

Member No.	Node End 1 End 2	Axial Force (kN)	Torque Moment (kNm)	Shear Force (kN)		Bending Moment (kNm)		Maximum Moment (kNm @ m)		Max Def (mm @ m)
				y-y	z-z	y-y	z-z	y-y	z-z	
1	G9	7.93C	0.20	3.50	0.54	0.00	0.00	1.16	0.16	0.03
	G10	7.50C	0.18	-4.15	0.09	0.00	0.00	@ 0.300	@ 0.297	@ 0.279

Classification and Effective Area (EN 1993: 2006)

Section (12.96 kg/m) 127x76 UB 13 [S 275]
Class = Fn(b/T,d/t,f_y,N,M_y,M_z) 5, 24.15, 275, 7.93, 1.16, 0.16 (Axial: Non-Slender) Class 1

Auto Design Load Cases 1

Shear Capacity Check

V_{y,Ed}/V_{pl,y,Rd} 4.153 / 101.887 = 0.041 OK
V_{z,Ed}/V_{pl,z,Rd} 0.538 / 183.413 = 0.003 OK

Local Capacity Check

V_{y,Ed}/V_{pl,y,Rd} 3.583 / 101.887 = 0.035 Low Shear
M_{c,y,Rd} = f_y · W_{pl,y} / γ_{M0} 275 x 84.2/1 23.155 kN.m
V_{z,Ed}/V_{pl,z,Rd} 0.538 / 183.413 = 0.003 Low Shear
M_{c,z,Rd} = f_y · W_{pl,z} / γ_{M0} 275 x 22.6/1 6.215 kN.m
N_{pl,Rd} = A_g · f_y / γ_{M0} 16.51 x 275/1 = 454.025 kN
n = N_{Ed}/N_{pl,Rd} 7.935 / 454.025 = 0.017 OK
W_{pl,N,y} = Fn(W_{pl,y}, A_{vy},) 84.2, 6.417, 0.017 84.2 cm³
M_{N,y,Rd} = W_{pl,N,y} · f_y / γ_{M0} 84.2 x 275/1 23.155 kN.m
W_{pl,N,z} = Fn(W_{pl,z}, A_{vz},) 22.6, 11.552, 0.017 22.6 cm³
M_{N,z,Rd} = W_{pl,N,z} · f_y / γ_{M0} 22.6 x 275/1 6.215 kN.m
(M_{y,Ed}/M_{N,y,Rd} + (M_{z,Ed}/M_{N,z,Rd}))² + (0.161/6.215)² = 0.028 OK

Compression Resistance N.b.Rd

L_{ey} = K_y · L_y 1x0.6 = 0.6
λ_y = √(A · f_y / N_{cr}) √(16.51x275/27306.73) 0.129
N_{b,y,Rd} = Area · c · f_y / γ_{M1} 16.51x1x275/10/1 = 454.025 kN Curve a
L_{ez} = K_z · L_z 1x0.6 = 0.6
λ_z = √(A · f_y / N_{crz}) √(16.51x275/3258.62) 0.374
N_{b,z,Rd} = Area · c · f_y / γ_{M1} 16.51x0.936x275/10/1 = 425.161 kN Curve b
L_{et} = K_t · L_x 1x0.6 = 0.6
λ_T = √(A · f_y / N_{crT}) √(16.51x275/4264.87) 0.326
N_{b,T,Rd} = Area · c · f_y / γ_{M1} 16.51x0.954x275/10/1 = 433.317 kN Curve b

Equivalent Uniform Moment Factors C1, C.mLT, C.mz, and C.my

C₁ = fn(M₁, M₂, M₀, ~y, ~m) 0.0, 0.0, 1.0, 1.000, 300.000 1.348 Point
C_{mLT} = 0.90 + 0.10a_h M_h = 0, M_s = 1.04, ~y = 1.000, a_s = 0.002 0.9 Table B.3
C_{mz} = 0.90 + 0.10a_h M_h = 0, M_s = 0.16, ~y = 1.000, a_s = 0.001 0.9 Table B.3
C_{my} = 0.90 + 0.10a_h M_h = 0, M_s = 1.04, ~y = 1.000, a_s = 0.000 0.9 Table B.3

Lateral Buckling Check M.b.Rd

L_e = 1.00 L 1 x 0.6 = 0.6 m
M_{cr} = Fn(C₁, L_e, I_z, I_t, I_w, E) 1.348, 0.600, 56.6, 2.851, 0.001982, 210000 284.946 kN.m

STRUCTURAL CALCULATION



Hibbert Smith Consulting Ltd – Structural & Civil Engineers
T: 07949 171 787 W: www.HibbertSmith.com

Project Ref				P22-0006.128				Project Title				Generic Mobile Home Lifting			
Doc Ref				P22-0006-HSC-Ca-S-128				Doc Title				Generic Mobile Home Lifting Assessment			
Version No	Date	Calcs By:	RJS	Date	Aug 23	Check By:	RS	Date	Aug 23	Appr'd By:	RJS	Sheet No	86	Sheet Version	01

$\lambda_{LT} = \sqrt{W \cdot f_y / M_{cr}}$	$\sqrt{84.2 \times 275 / 284.946}$	0.285	
$C_{LT} = F_n(\lambda_{LT}, \Phi_{LT}, \beta, \lambda_{LT}0)$	0.285, 5.801, 0.750, 0.400	1.000	Curve d
$C_{LT.mod} = F_n(C_{LT}, \lambda_{LT}, k_c, f)$	1.000, 0.285, 1.000, 1.000	1.000	6.3.2.3
$M_{b.Rd} = C \cdot W_{pl.y} \cdot f_y \leq M_{c.y.Rd}$	$1.000 \times 84.2 \times 275 \leq 23.155 =$	23.155 kN.m	

Buckling Resistance

$U_{N.y} = N_{Ed} / (C_y \cdot N_{Rk} / \gamma_{M1})$	7.935 / 454.025	0.017	OK
$U_{N.z} = N_{Ed} / (C_z \cdot N_{Rk} / \gamma_{M1})$	7.935 / 425.161	0.019	OK
$U_{M.y} = M_{y.Ed} / (C_{LT} \cdot M_{y.Rk} / \gamma_{M1})$	1.041 / 23.155	0.045	OK
$U_{M.z} = M_{z.Ed} / (M_{z.Rk} / \gamma_{M1})$	0.161 / 6.215	0.026	OK
$k_y y = C_{my} \{1 + (\lambda_y - 0.2) U_{N.y}\}$		0.899	
$k_z z = C_{mz} \{1 + (2\lambda_z - 0.6) U_{N.z}\}$		0.903	
$k_y z = 0.6 k_z z$		0.542	
$k_z y = 0.6 k_y y$		0.539	
$U_{Ny} + k_y y \cdot U_{M.y} + k_y z \cdot U_{M.z}$	$0.017 + 0.899 \times 0.045 + 0.542 \times 0.026$	0.072	OK
$U_{Nz} + k_z y \cdot U_{M.y} + k_z z \cdot U_{M.z}$	$0.019 + 0.539 \times 0.045 + 0.903 \times 0.026$	0.066	OK

Deflection Check - Load Case 2

In-span $\delta \leq \text{Span}/360$	$0.03 \leq 600 / 360$	0.03 mm	OK
---------------------------------------	-----------------------	---------	----

Appendix K – Construction Methodology



In order to Comply with The Caravan Act.
The Annex Caravan Structure MUST be Constructed in Two Halves along the Joint Line as
Shown within the Working Drawing Document
with a Standard 50mm Definitive Gap between the Two Halves.

All Electric/Water Connections, between the Joint Line Must
Utilise the Use of Commando Sockets, and Appropriate Trims to be used on All External
Cladding and Roofing Products including Soffits & Facias.

The Final Act of the Build will be the Union of Both Halves

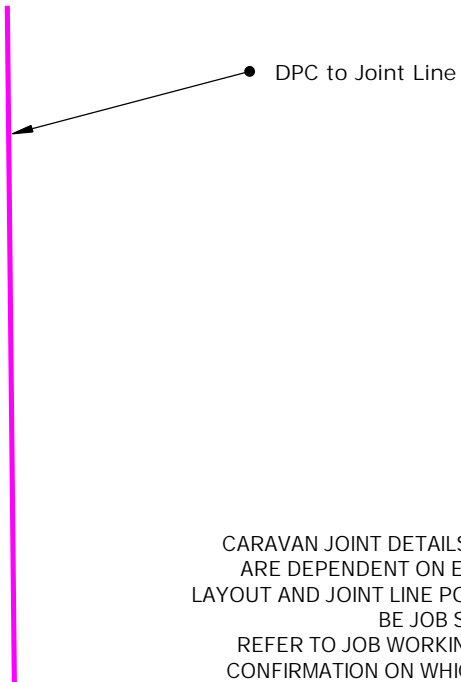
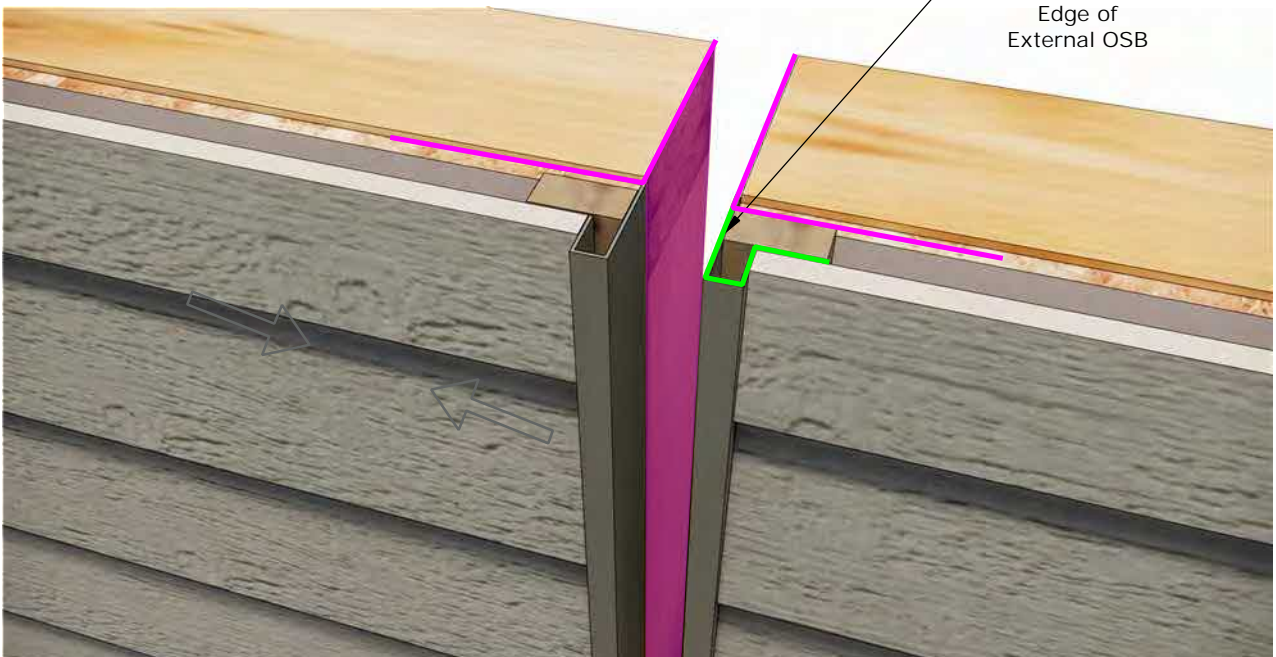
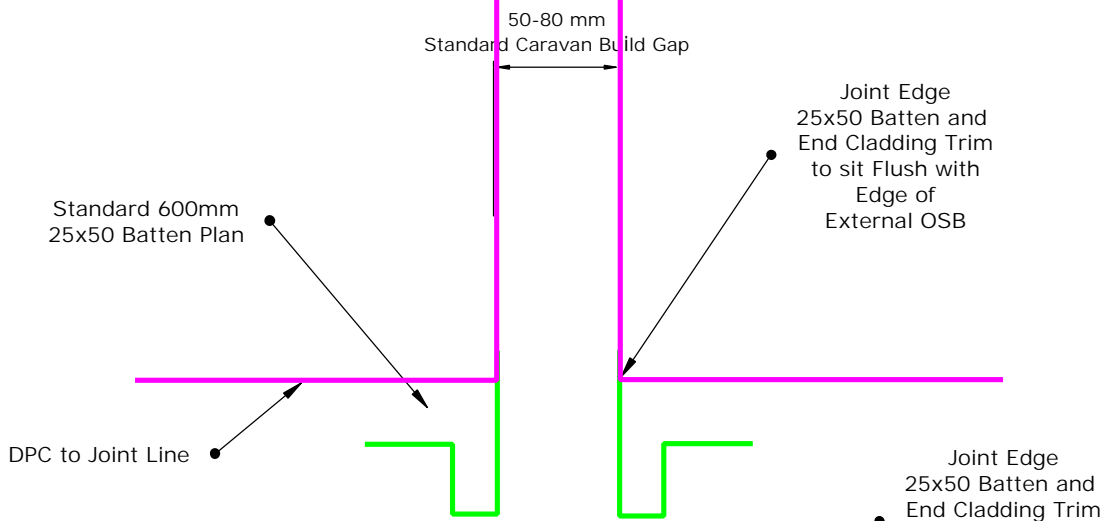

CARAVAN JOINT DETAILS, BOTH TYPE 1 & TYPE 2 ARE DEPENDENT ON ELEVATIONAL WINDOW LAYOUT AND JOINT LINE POSITION, AND AS SUCH WILL BE JOB SPECIFIC.
REFER TO JOB WORKING DRAWING PACK FOR CONFIRMATION ON WHICH TYPE IS TO BE USED.

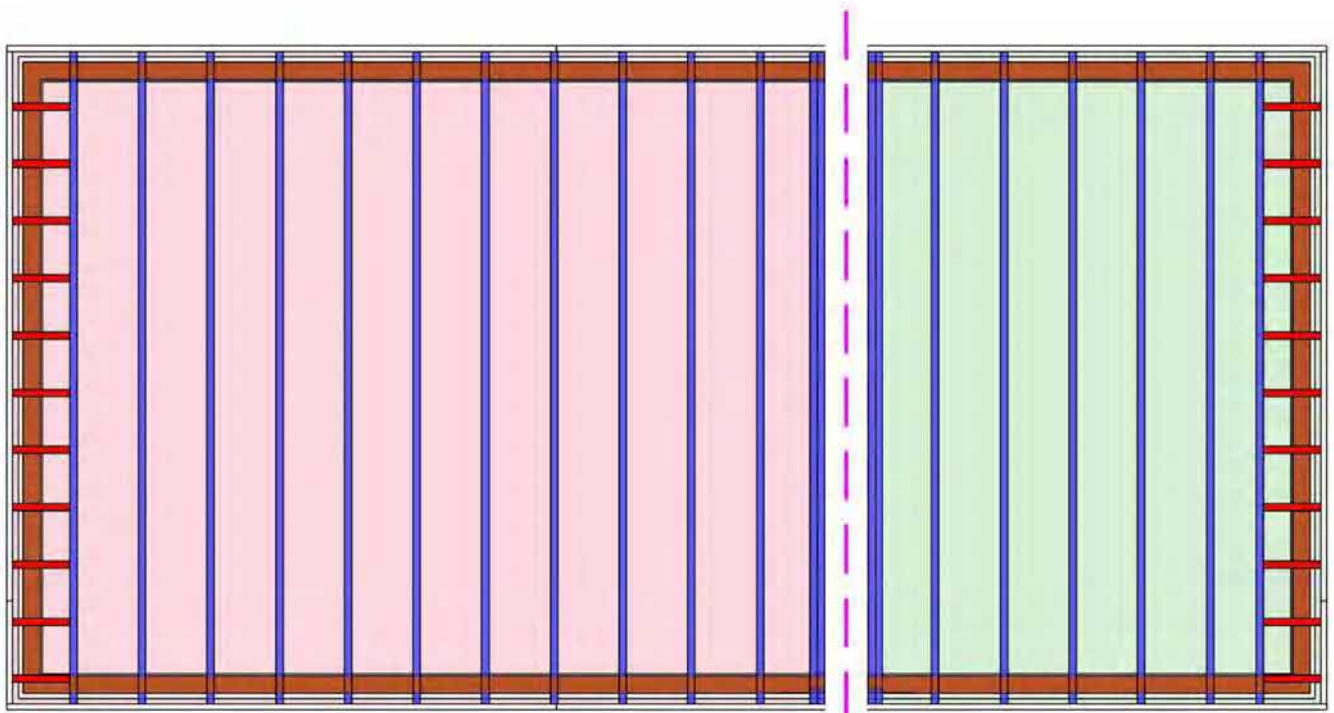

50-80mm Joint Separation
Until the Final Act

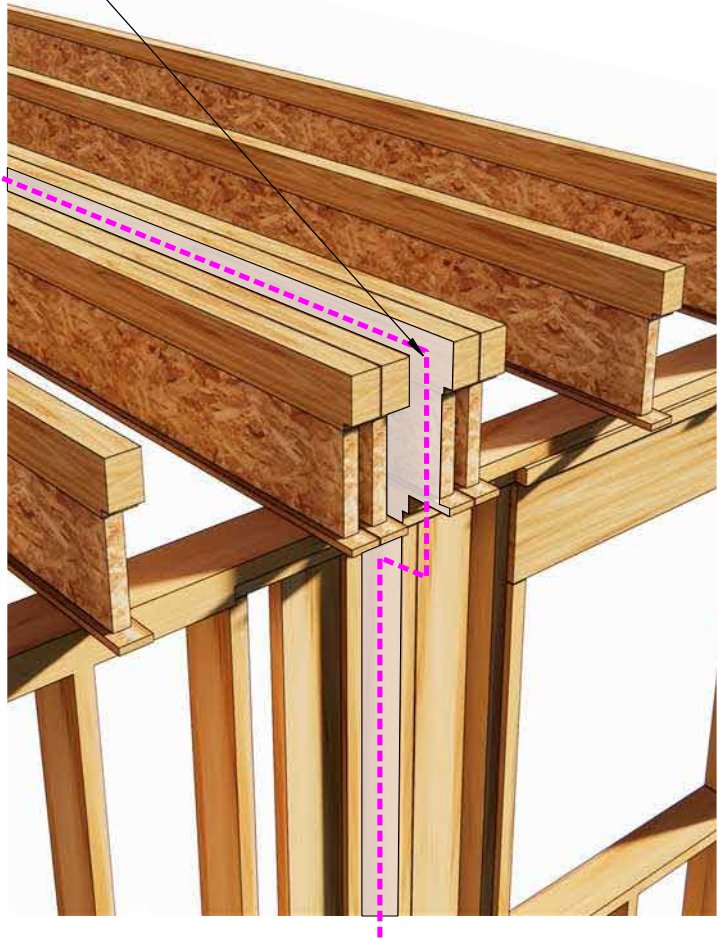
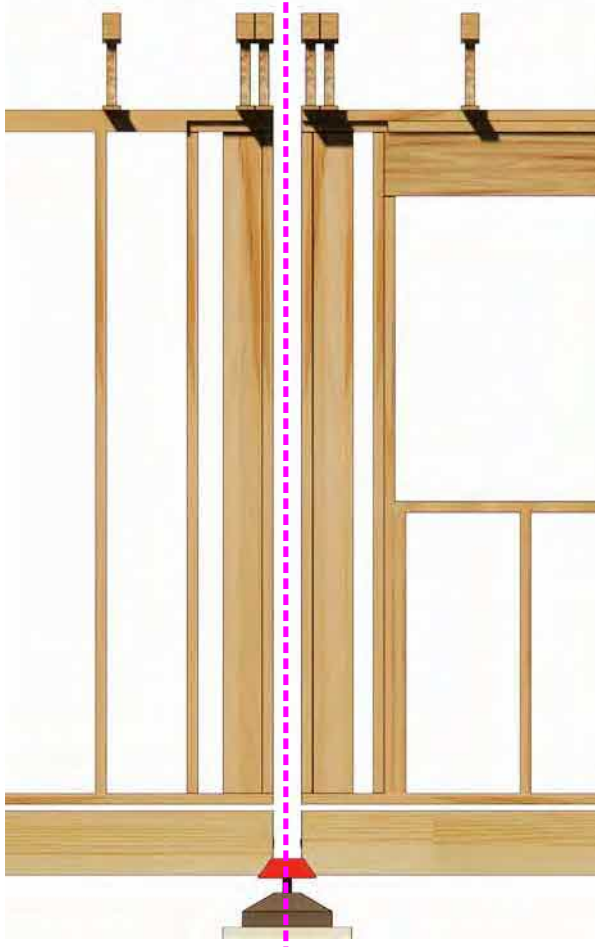

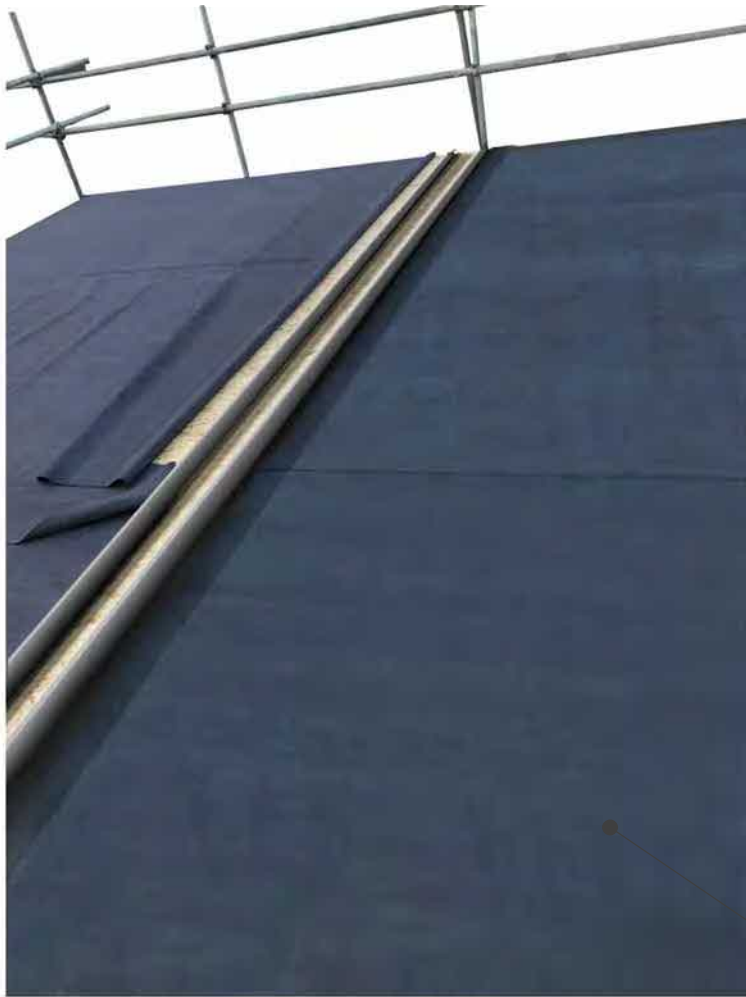

Flat Roof Finish Trim to Joint Line



JOINT TRIM APPLIED TO PITCHED ROOF SITUATION

TYPICAL ELECTRIC PLAN

- | | | | |
|--|---------------------|--|-------------------|
| | SINGLE SOCKET | | TV CABLE POINT |
| | DOUBLE SOCKET | | PHONE POINT |
| | DOUBLE SOCKET W/USB | | EXTRACTOR FAN |
| | 10 AMP FLEX OUTLET | | C. UNIT/ F. BOARD |
| | FUSED SPUR | | COOKER SWITCH |
| | S LIGHT SWITCH | | SMOKE ALARM |
| | D LIGHT SWITCH | | HEAT DETECTOR |
| | OD LIGHT | | RADIATOR |
| | PIR OS LIGHT | | EXTERNAL SOCKET |
| | DOWNLIGHT | | |
| | IP DOWNLIGHT | | |
| | UNDER UNIT LIGHT | | |

Wherever a Kitchen Extractor is located on an External Wall, the through wall vent kit must be used not the charcoal filter, this is a building control requirement.

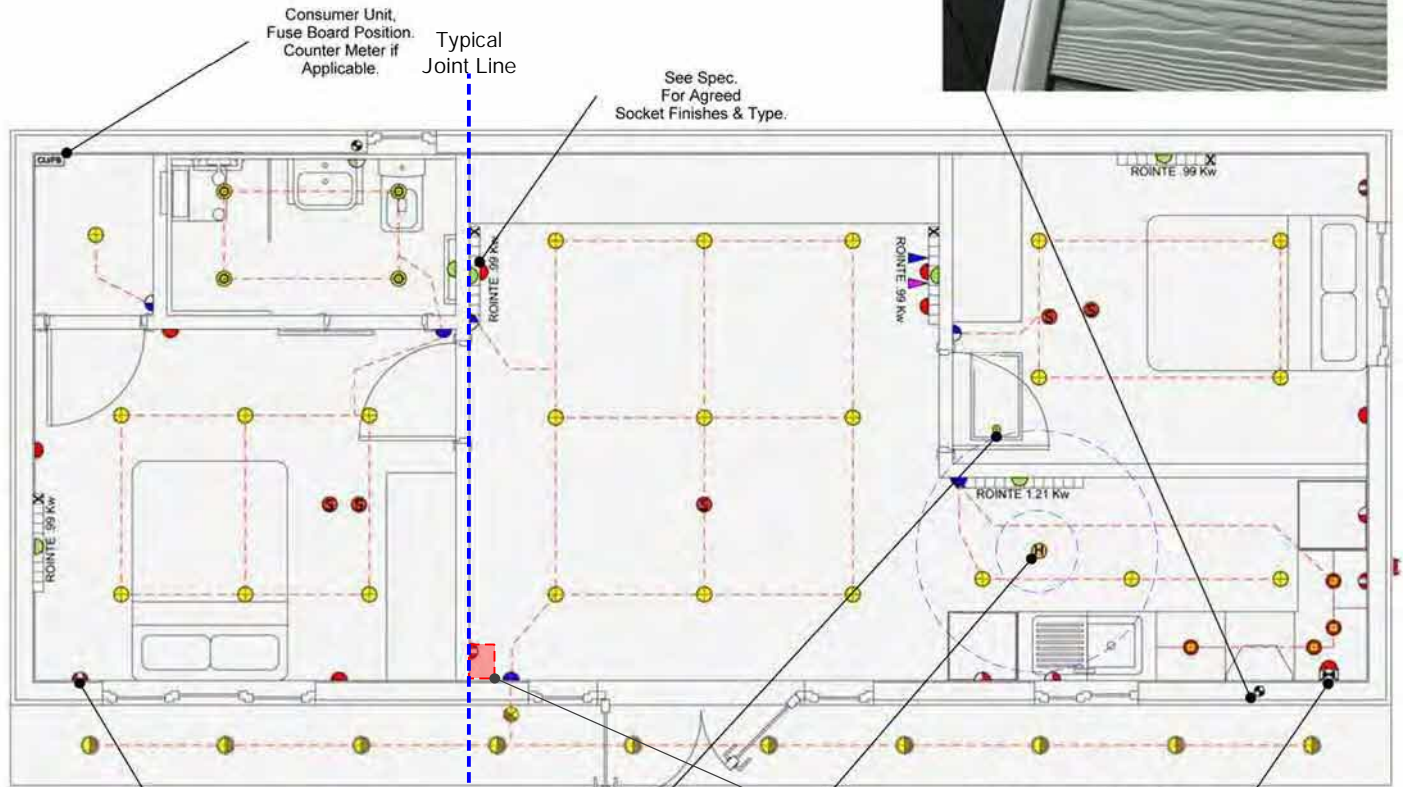

All Internal Power Sockets & Light Switches to be Located Between 450mm Min. to 1200mm Maximum to comply with Part M Building Regulations, Unless the Annex is specifically designed for a person with Limited Reach.

All above Counter Power Points to be set at a Minimum of 300mm Distance from All Primary Heat & Water Sources

Light on Pull Cord to All Loft Hatches
Heat / Smoke Detectors to be Positioned 1500mm Min. from Primary Kitchen Heat Sources & 300 mm Min. from Light Fixtures

All Electric & Water Connections to Utilise Commando Sockets & Fittings Via Inspection Hatches along the Joint Line, Preferably set in the Ceiling Void when Possible.



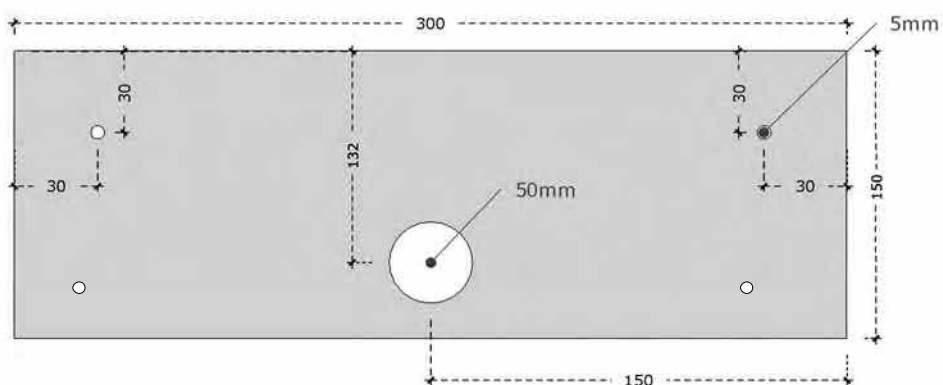
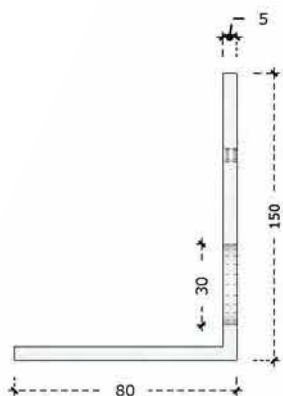
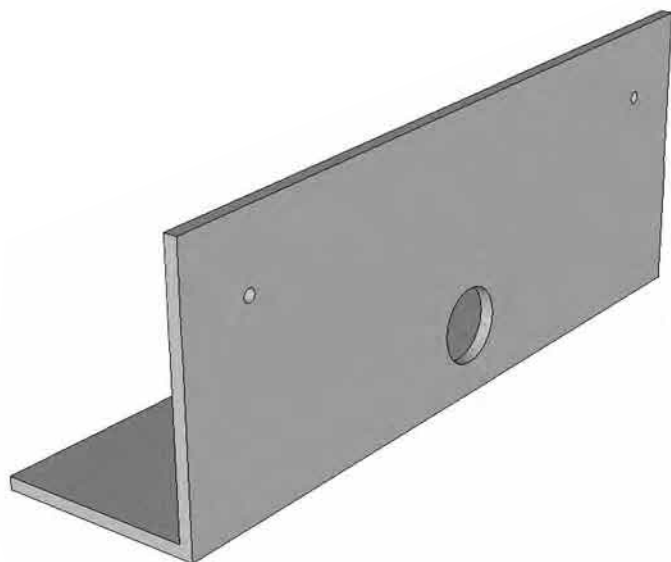
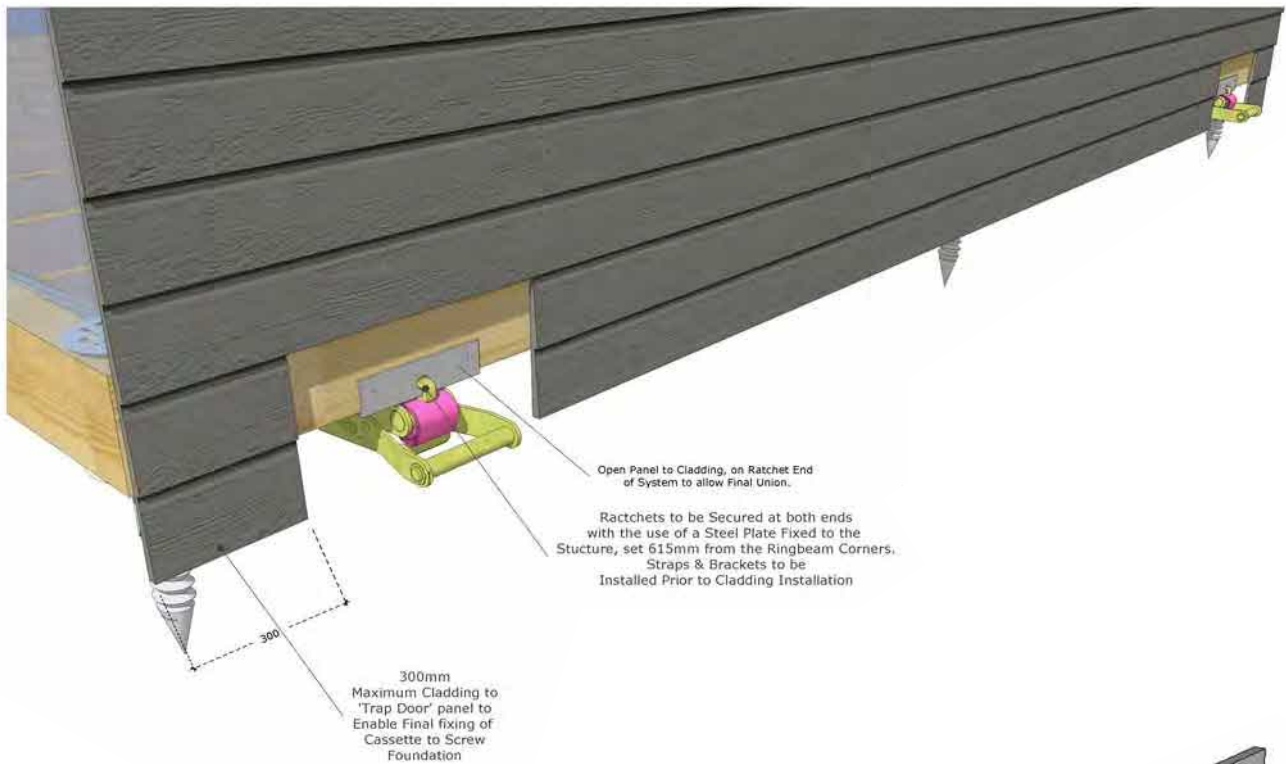

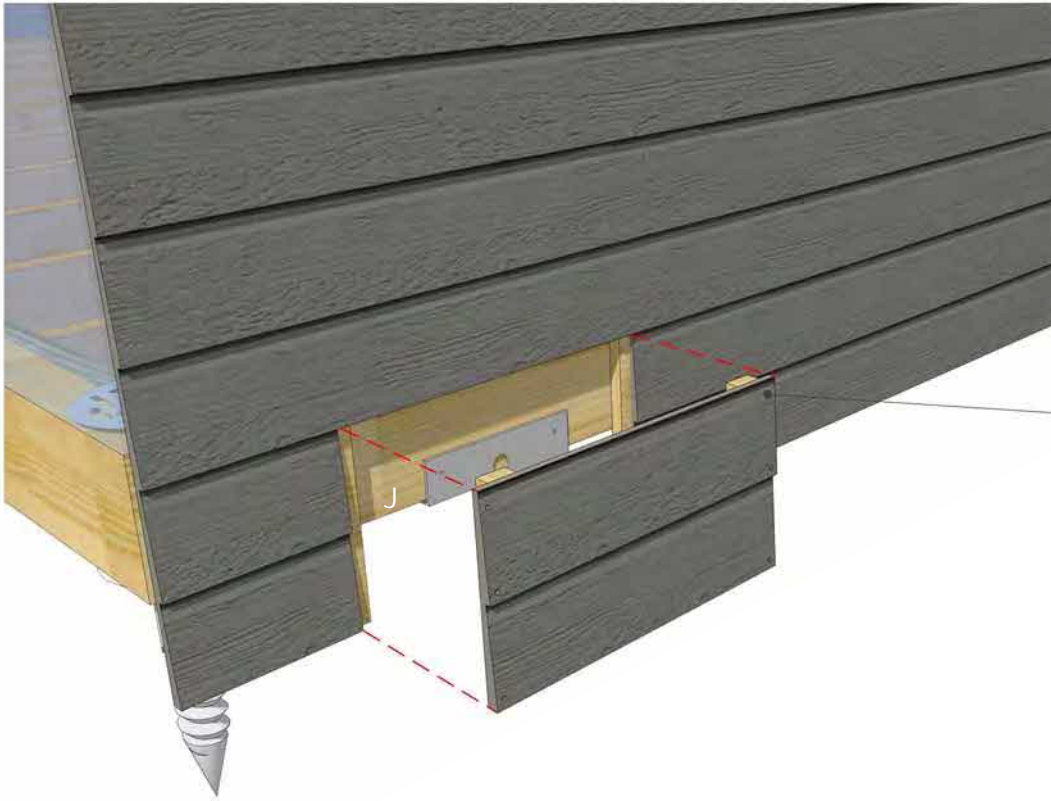

Bracket 'Trap Doors'
to Be fixed with Stainless Steel
Screws finished with Caps
to match Cladding Choice

Bracket 'Trap Doors'
to Be fixed with Stainless Steel
Screws finished with Caps
to match Cladding Choice



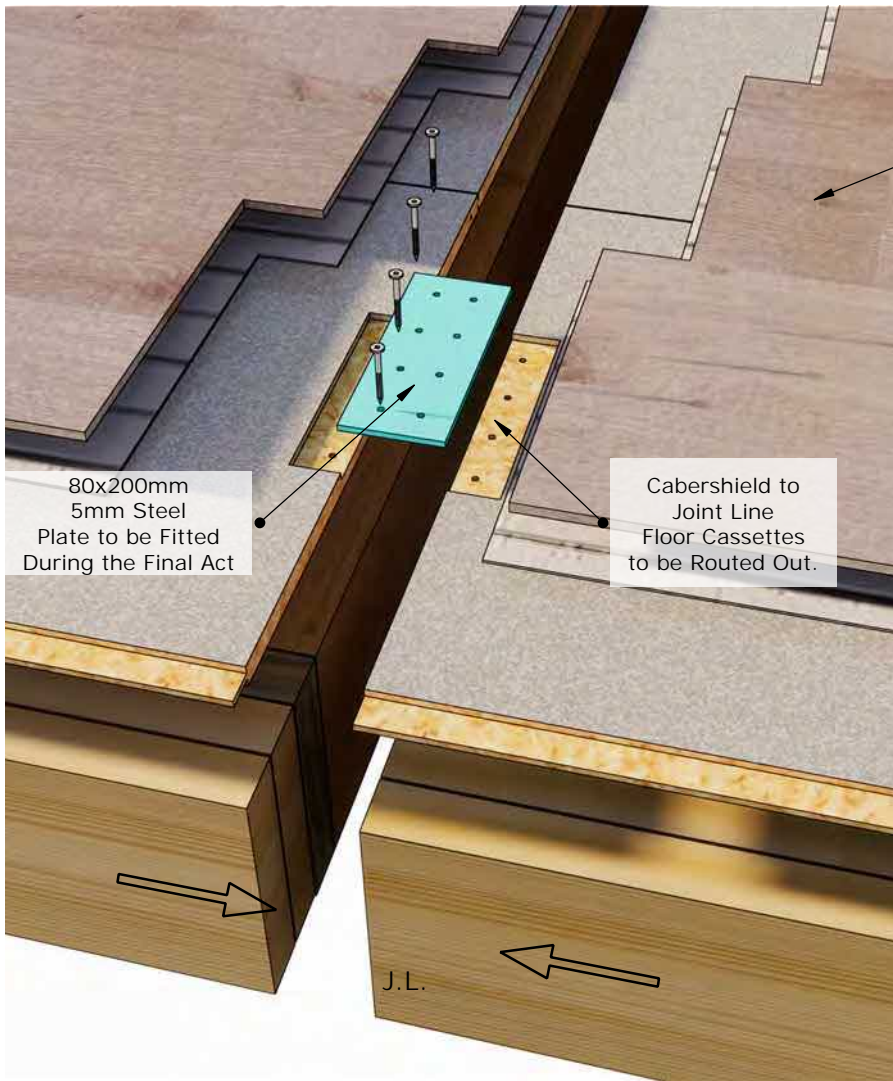

Flooring to be fitted once Final Act has been completed, to All Rooms affected by the Joint Line

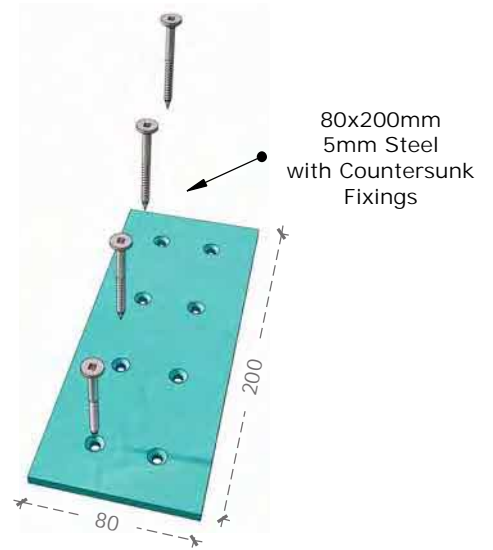

Floor Connection Plates to be set 400mm from Cassette Edge to Plate Centre

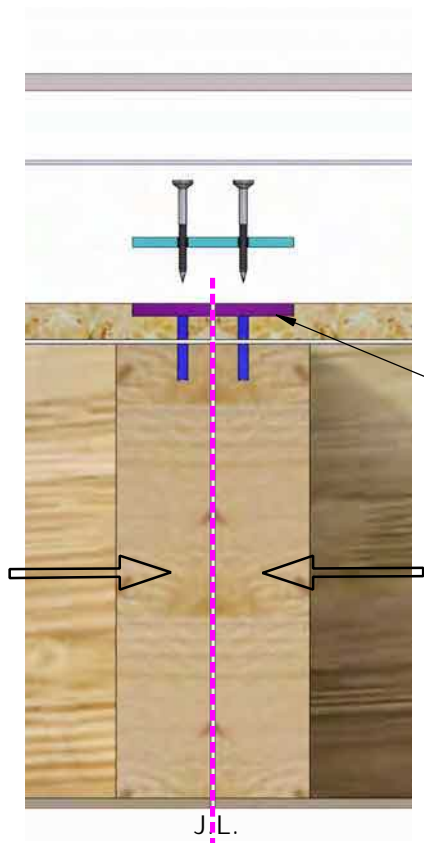
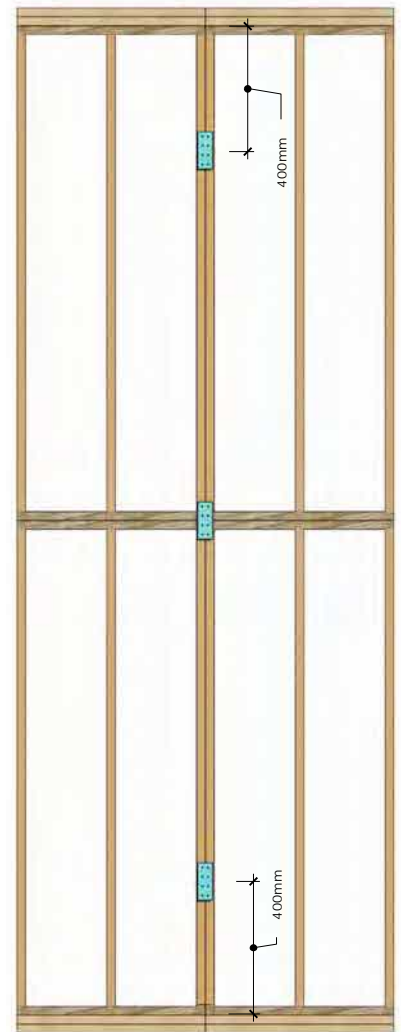

Cabershield to Joint Line Floor Cassettes to be Routed Out.