

DG DARK PC ALUMINUM FIXED ROOF LIGHT SET 150 ABOVE ROOF LANE SO STILL NOT VISIBLE ON ELEVATION

INSULATION EDGING AS MANUFACTURERS DETAILS
ROOFLIGHT 800 X 800 MM (SIMILAR IN WIDTH TO SASH WINDOWS)

SASH WINDOWS AND DOORS TO SUMER ROOM ALL HARDWOOD JOINERY / PAINTED
CENTRAL OUTWARD OPENING
DOORS TO LONG ELEVATION WITH SASHES EITHER SIDE
2 NO PAINTED POSTS WITH FLUTED DIVISIONS

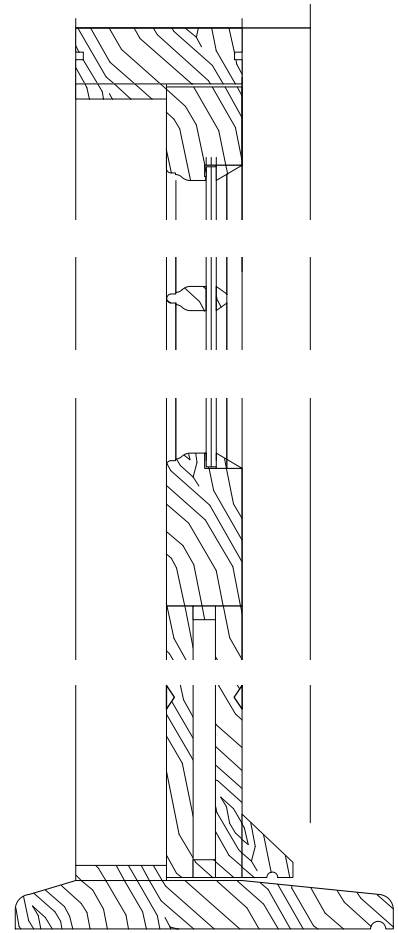

SECTION DETAIL DOOR 1:5

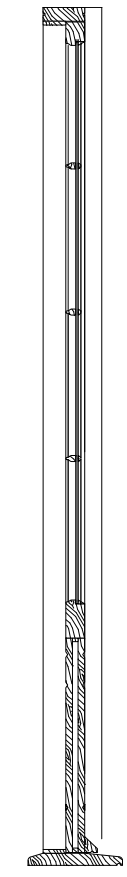

SECTION DETAIL DOOR 1:20

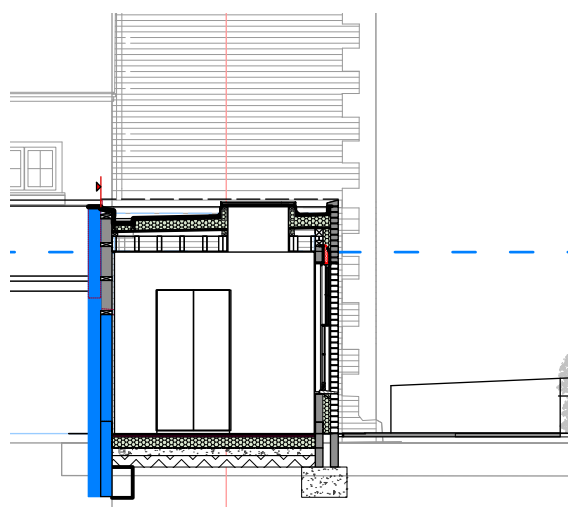
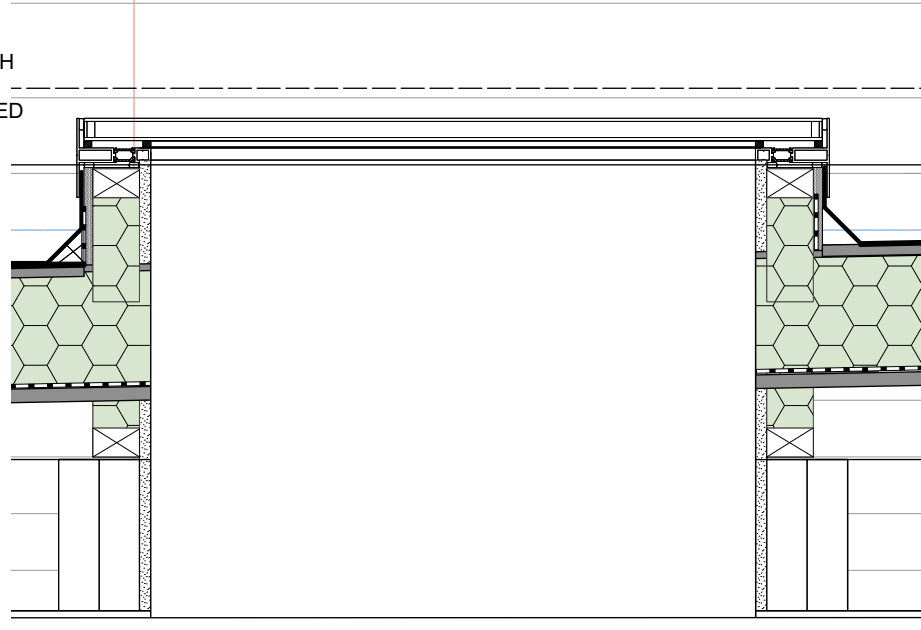

CROSS SECTION SUMMER ROOM 1:100

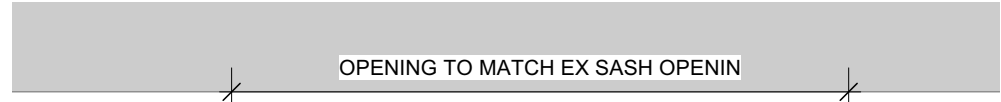

OPENING TO MATCH EX SASH OPENIN

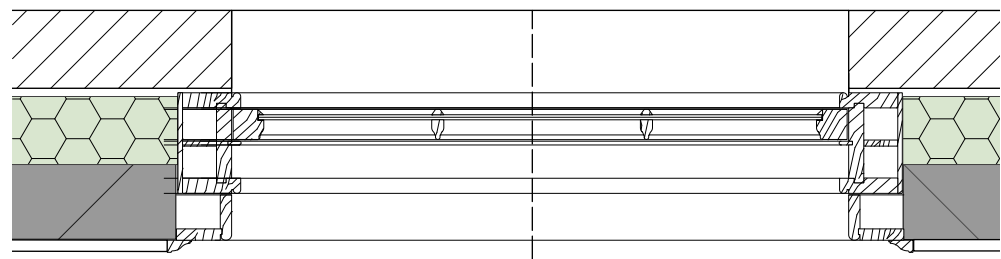

PLAN SASH TYPICAL SASH WINDOW

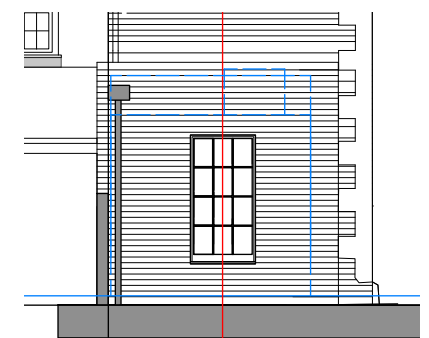

ELEVATION 2 SUMMER ROOM 1:100
ALSO REFER OVERALL ELEVATION

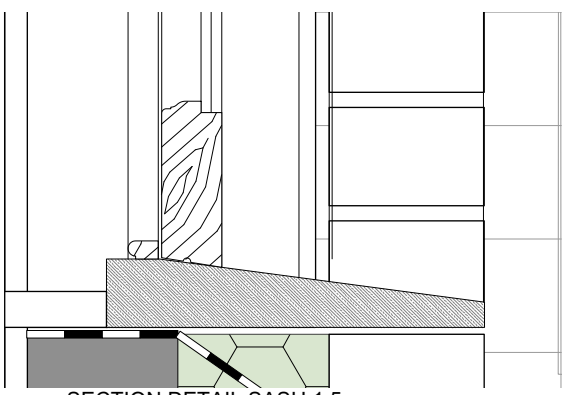
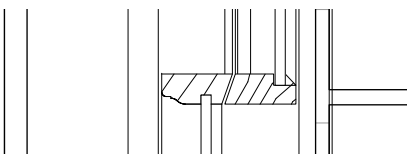
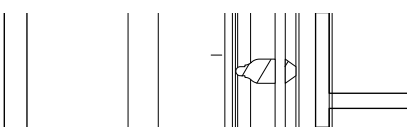
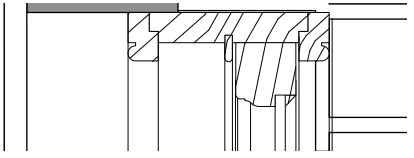

SECTION DETAIL SASH 1:5

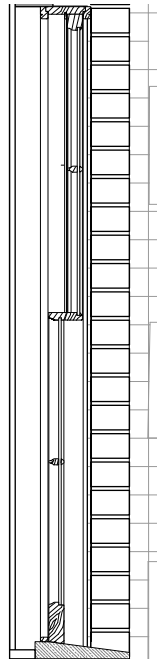

SECTION DETAIL SASH 1:20

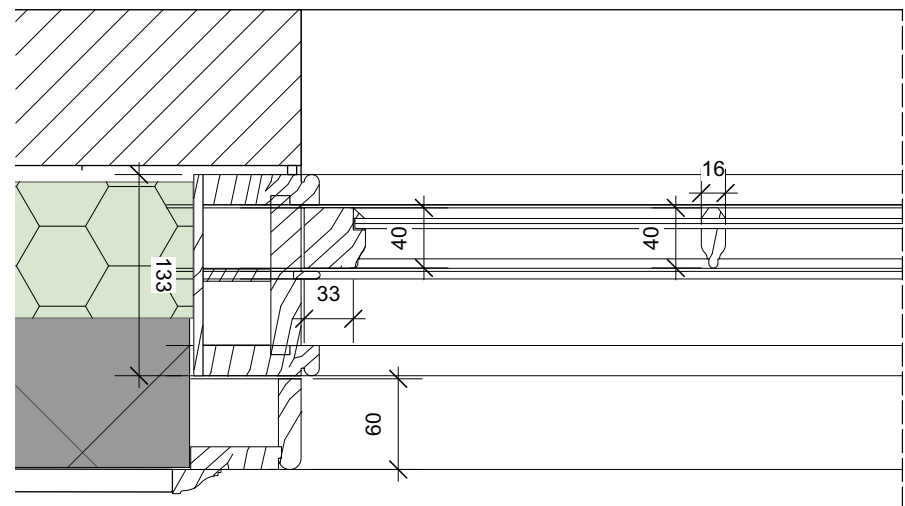

PLAN DETAIL - SASH TYPICAL SASH WINDOW 1:5

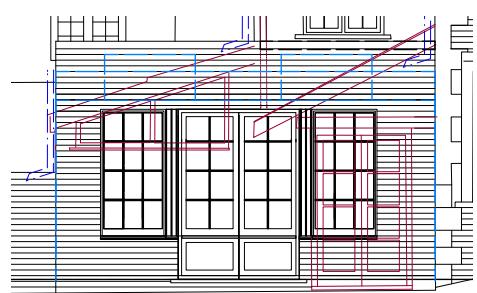

ELEVATION 1 SUMMER ROOM 1:100
ALSO REFER OVERALL ELEVATION

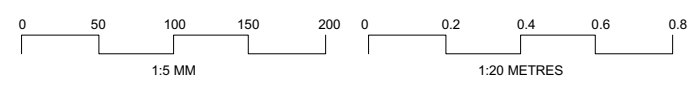
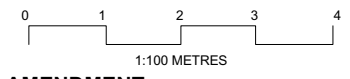

AMENDMENT:
A:

DATE
00.00.00

Status DISCHARGE CONDITIONS

Job no / drawing no 858 A 10
Job title 1 GAINSBOROUGH



Drawing title
Summer Room Elevations

Date JAN 2024
Sheet A3
Scale var
Drawn by ST
Checked by ST

www.hetreedross.com 01225 851860
Do not scale