

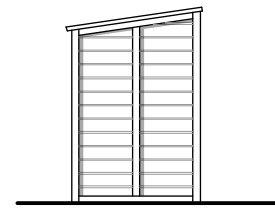

FRONT ELEVATION

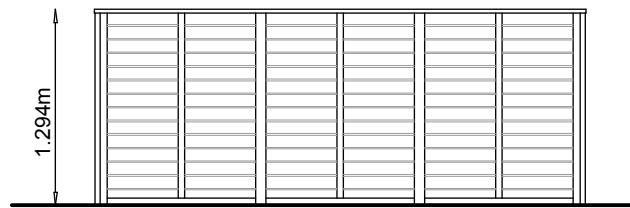

SIDE ELEVATION



REAR ELEVATION

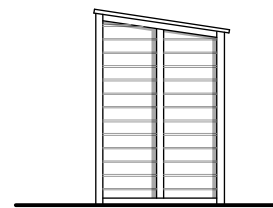

SIDE ELEVATION

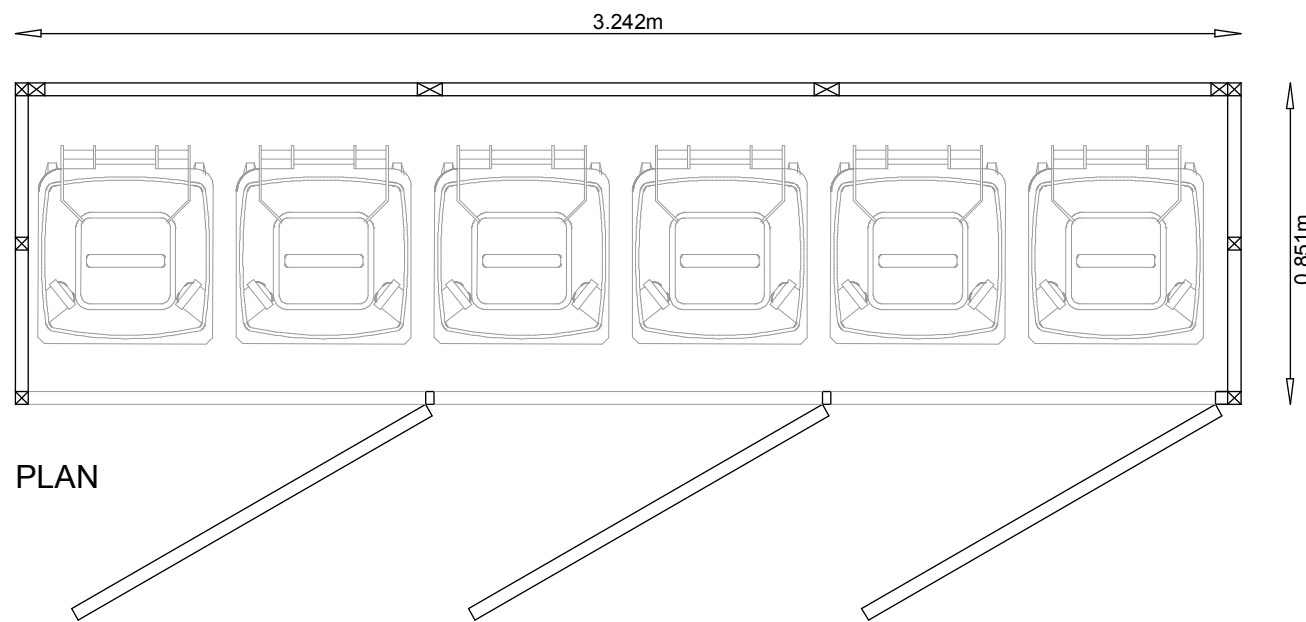

PLAN



SCALE VERIFICATION BAR SCALE 1:20 @ A3



SCALE VERIFICATION BAR SCALE 1:50 @ A3

NOTES:
ALL DIMENSIONS MUST BE CHECKED ON SITE AND NOT
SCALED FROM THIS DRAWING

Date	Revisions

Copyright

PLANS
ARCHITECTURAL DESIGN SHOP

PLANS
18 GODSTONE ROAD
CATERHAM
SURREY CR3 6RA
TEL: 01883 344415

Client

Job Title
133, LONGFLEET ROAD,
POOLE. BH15 2HS.

7 ROOM HMO

**BIN STORE - PLAN &
ELEVATIONS**

Scale 1:20 & 1:50 @ A3

Date SEP. 2023

Drwg. No.	23/431-07	Rev.	
-----------	-----------	------	--