

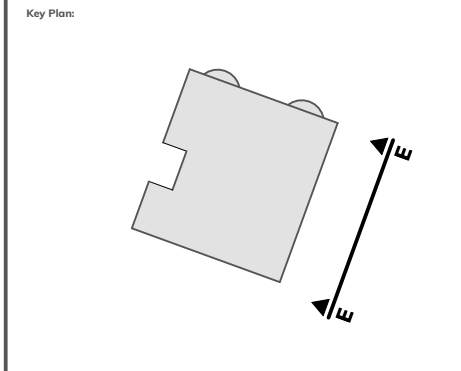

**E GA Elevation East - Existing**  
1 : 100

- 1 Brick chimney with clay pots
- 2 Natural slate roof
- 3 Rooflight
- 4 Painted stone detail
- 5 Existing Painted timber frame windows
- 6 Lead to Window Bay Roof
- 7 Window Bay
- 8 Brickwork
- 9 Ironwork
- 10 Red ridge tiles
- 11 Brickwork infill
- 12 New timber frame windows
- 13 New timber frame door
- 14 New curtain wall
- 15 New lead surround walls
- 16 Secondary glazed facing London Road
- 17 Stone sills
- 18 Adjoining existing building



- General Notes:
- Do not scale off this drawing unless a scale bar is provided.
  - Any ambiguities, omissions and errors on this drawing should be notified immediately to the Architect before the commencement of works on site.
  - Dimensions are in millimetres unless otherwise stated.
  - Dimensions, unless otherwise indicated, are to the face of unfinished block walls or to the finished plaster face of stud partitions.
  - Dimensions are to be checked on site. Discrepancies are to be notified immediately to the Architect before the commencement of works on site.
  - All levels are in meters unless otherwise stated.
  - This drawing is to be read in conjunction with all other relevant drawings and specifications for this project.

Revision Notes:

Rev.	Date	Notes	Issuer	Checker
P1	2023-08-04	Preliminary Issue P1	IAT	JC
P2	2023-09-12	Minor refinements to existing drawings.	MJ	JC
P3	2023-10-06	Further detail added to elevations. Status Updated to A3 Planning	MJ	JC
P4	2023-10-09	Minor elevation updates	MJ	JC
P5	2021-10-17	Planning Submission	MJ	JC



**LONDON ROAD  
NEWARK**

Job Number: 23-0030  
Project Address: London Rd, Newark NG24 1TW  
Client Name: Bildum Properties

Director / Associate: Matthew Branton  
Project Lead: Sarah Boxford  
Status: A3 Planning  
Functional Breakdown: B2 - Building 2  
Sheet Size: A3L  
Scale: 1 : 100

Drawing Name:  
**GA East Elevation Existing - Block 2**

Full Document Reference:  
BLR-FEA-B2-ZZ-DE-A-3523

Document Number: **3523**  
Current Revision: **P5**  
Revision Date: **2021-10-17**

