

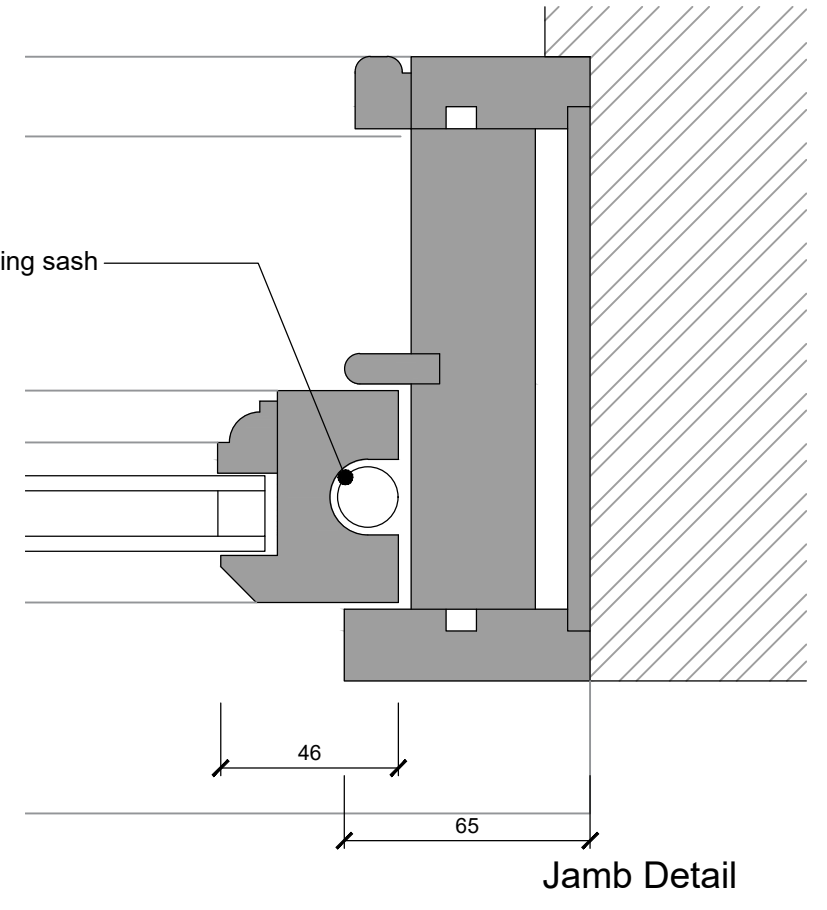

NB: Strip seals and glazing tape not shown.
All timber to be finished in gloss white

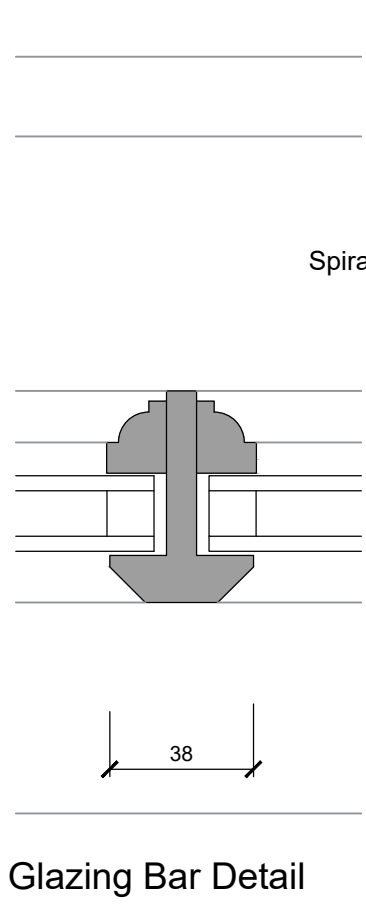

client Mr A Evans	drawing title Joinery Details - West Window	ref 1623	drawing no. PA04	rev	Tricker Blackie Associates Chartered Architects Project Management Planning Consultants 
project Proposed Alterations- 57 High Street. Lavenham		date Jan 2024	scale 1:2@A3	drawn by -	