



Technical Submittal Issue Sheet

Project Name	Burlington Junior School	Project No	C2025
Originator:	Martin Davies	Submission No:	TSE-002
Issued to:	Morgan Sindall	Revision:	1
Copies Sent to:			
Service:	Electrical		
Date:	19/09/2023		

Description of items for approval:

The CLS LED Areolite -27 is an installer friendly Led light mounted on an 8 metre column.

Please respond by: 7 days

	STATUS	A	B	C	
	✓ as appropriate				

Status A – The above has been reviewed accepted

Status B - The above is accepted, subject to the following comments:

Status C – The above has been rejected for the following reasons:

Name: _____ **Date:** _____ **On behalf of:** _____



Areolite-27

LED street light, detachable head

20W to 240W



The CLS LED Areolite-27 range is probably the most installer-friendly LED street light available. The larger LED and driver unit can be quickly removed, tool free, from the base unit allowing the smaller, lighter base unit to be fixed, levelled and wired. The larger unit can then be quickly refitted to the base unit, the unit closed and locked and ready to operate.

With the wide range of options available the Areolite-27 can work with most CMS system and is truly future-proof.



- Powder coat die-cast Aluminium case with tool-less detachable light engine. IP66.
- Sosen driver (standard).
- 0-10V dimming, dim-to-off, DALI 2, D4i (option).
- Lumileds 3030 LED chips.
- CCT 1900K to 6500K.
- 10kV SPD standard.
- Safety power cut-off switch.
- Screwless connector blocks.
- 3, 5 or 7 pin NEMA (option).
- Zhaga Book 18 receptacle.
- Multi-step dimming microwave motion sensor (option).
- Tempered glass IK09.
- PC lens. Range of optics.
- Side entry or post top mount.
- Spigots available from 34mm to 76mm. $\pm 15^\circ$ adjustment.

Areolite-27

LED street light, detachable head

20W to 240W

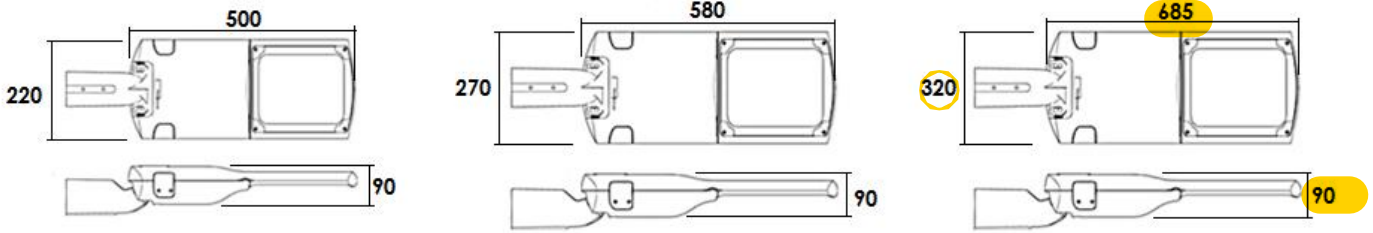

Model	SH27											
Power	20W	30W	40W	50W	60W	80W	100W	120W	150W	180W	200W	240W
Lumens Nom.	2800	4200	5300	6300	7300	10400	12700	15600	19500	23400	27700	34000
LED Qty	96						192			320		
LED type	Philips Lumiled Luxeon 3030. Other brands available on request											
CRI	>70											
Colour Temp.	3000K, 4000K, 5000K, 6000K or specified from 2000K to 7000K											
L70B10	>50,000 hours											
Driver	Sosen GA (80W to 200W) 200-277V, Sosen VA 100-277V. PF.0.95. Other drivers by request											
Beam Angle	60°x60°, 90°x90°, Type 2, Type 3, Type 4											
Dimensions	500*220*90mm						580*270*90mm			685*320*90mm		
G.W.	4.6kg						6kg			8.5kg		
Pole Dia.	Spigots for 48mm, 60mm, 76mm. Adaptor from 48mm to 34mm and 42mm											
Material	Case ADC12 aluminium, Cover toughened glass, Lens PC											
Protection	IP66, IK09											
Surge	10kV with standard internal SPD											
Packing												
G.W.												
Complies with all EU directives including EMC, LVD, RoHS, REACH												
Standard warranty 5 years												
All data are nominal. Full test data are available for design simulations.												
All packing information is nominal and will be confirmed at time of shipping.												
E&O E. CLS reserve the right to change details without notice.												

Part Number System					
Series	Driver	Power	CCT	Beam Angle	Options
SH27	SA= Sosen GA	20W	20=2000K	H=Type 2	00=None
	SB=Sosen VA	30W	30=3000K	J=Type 3	01= NEMA 3-pin
	SF=Sosen GA 0-10V	40W	40=4000K	For others ask sales	02= NEMA 5-pin
	SG=Sosen VA 0-10V	50W	50=5000K		03= NEMA 7-pin
	For others ask sales	60W etc.	60=6000K		

20W to 240W

Optics

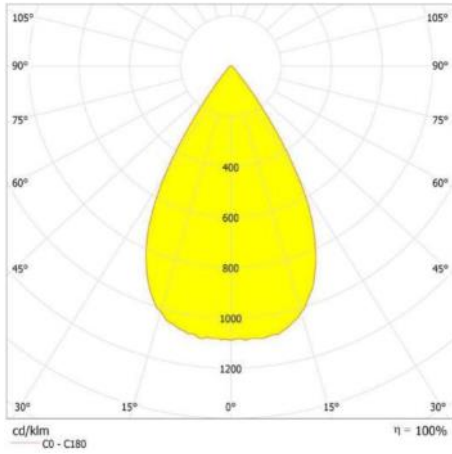

60°

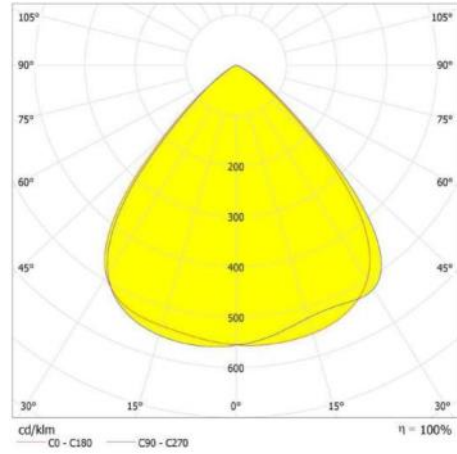

90°

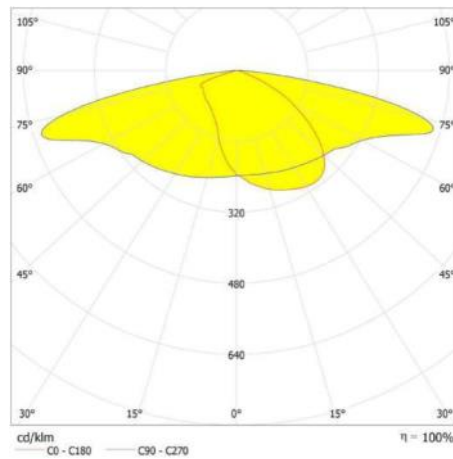

Type 2

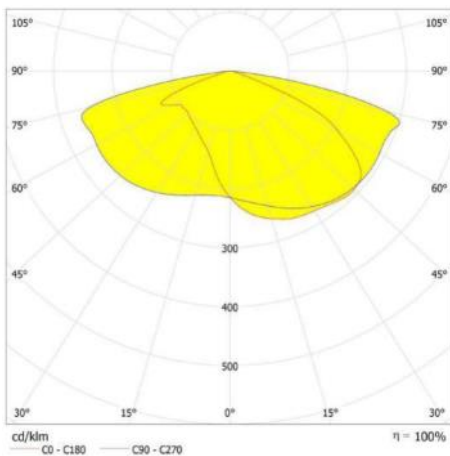

Type 3

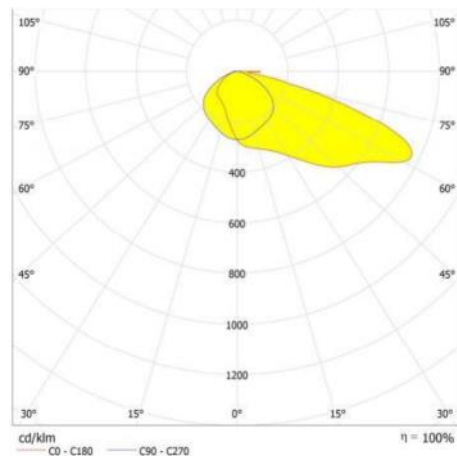

Type 4



Areolite-27

LED street light, detachable head

20W to 240W



10kV SPD with status light



Quick release spring clips



Screw-less terminal block



Silicon seal



IP67 7-10mm gland



Power safety cut-out switch



Areolite-27

LED street light, detachable head

20W to 240W



1.6mm aluminium PCB



Lumileds Luxeon
3030 LED

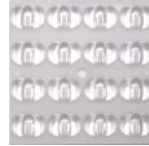

PC lens



4mm safety glass IK09

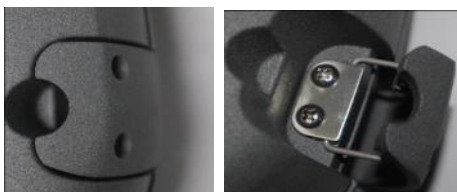

Tool free cover clips



Spirit level

Areolite-27

LED street light, detachable head

20W to 240W

Options



3 pin NEMA



5 pin NEMA



7 pin NEMA



Zhaga book 18



Multistep dimming
 motion sensor



360° Photocell



Shorting cap



CMS module



Spigot 34/42mm



Spigot 48mm



Spigot 60mm



Spigot 76mm

Areolite-27

LED street light, detachable head

20W to 240W

Installation



Open cover clips



Open cover



Release spring clips



Remove light unit



Fit base unit



Level



Connect power wires



Re-fit light unit



Close cover clips



Installation complete

Optional microwave motion sensor with multi-step dimming



Microwave motion sensor

PIR motion sensor

Zhaga Book 18 receptacle

- ◆ 5.8GHz C-band microwave or PIR
- ◆ 0-10V dimming or DALI broadcast output.
- ◆ Intelligent photocell can differentiate between natural light and LED light
- ◆ Memory function with one button commissioning.
- ◆ IR remote commissioning, easy setting and user friendly.
- ◆ Detection range up to max. 16~18m in diameter.
- ◆ Mounting height: max.12m.
- ◆ Operation temperature: -20 °c ~ + 70 °c.
- ◆ RoHS compliant.
- ◆ IP rating: IP65
- ◆ User can set daylight threshold, detection area, hold time, dim level and dim level time before off

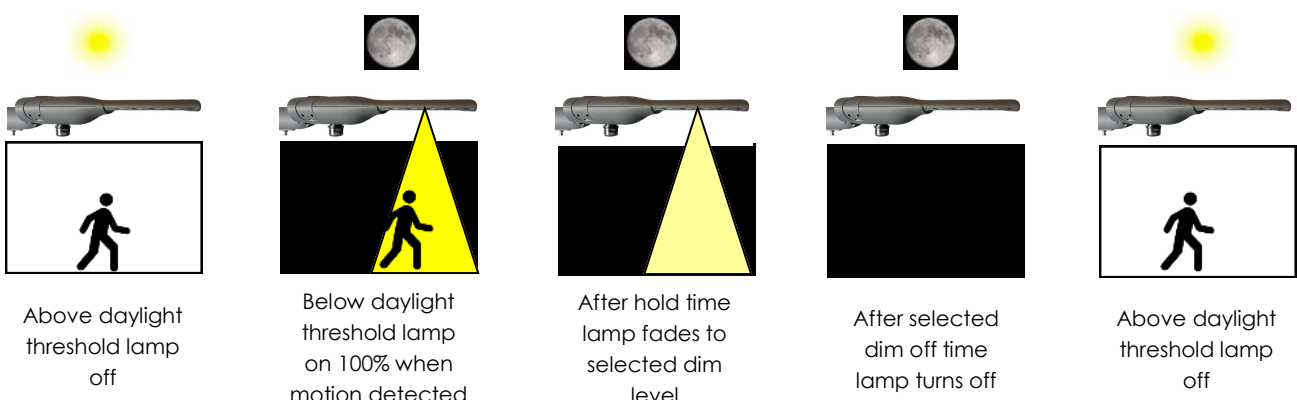

Technical Information

3rd Angle

*Maximum design head load based on wind loading region with orientation of bracket luminaire(s) being on same plane as door

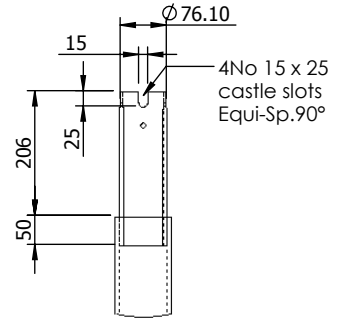

DETAIL A
SCALE 1 : 25

Maximum Loading including Bracket		
Wind Loading Region	Terrain Category	Weight/Area
Extra Light	I	45kg/0.40m ²
	II	55kg/0.50m ²
Light	I	40kg/0.34m ²
	II	48kg/0.43m ²
Medium	I	30kg/0.32m ²
	II	40kg/0.40m ²
Heavy	I	28kg/0.29m ²
	II	36kg/0.36m ²
Extra Heavy	I	22kg/0.22m ²
	II	30kg/0.25m ²

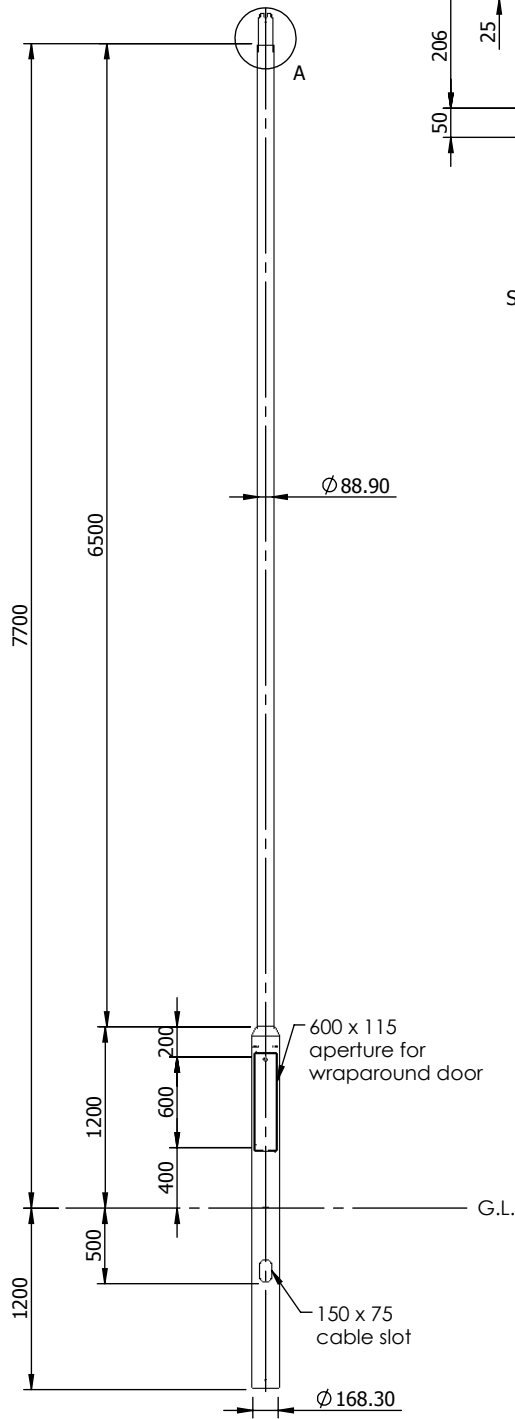

Revisions		
Rev.	Description	Date
1	Loading Table Added	15/06/22

Title
8 Metre Tubular Post Top Column

Drg No. n/a

Scale:1:25
Sheet 1 of 1

Drawn By: n/a

Chk'd: n/a

Ref. TC8M

Contract:

Customer: n/a

Date: 15/06/22