

- NOTES:
1. ALL DIMENSIONS TO BE CONFIRMED ON SITE.
  2. ANY DISCREPANCIES BETWEEN THE DRAWING AND SITE CONDITIONS SHALL BE BROUGHT TO THE ATTENTION OF THE DESIGNER.
  3. SITE BOUNDARIES, DIMENSIONS AND AREAS SHOWN ON THIS DRAWINGS ARE INDICATIVE ONLY AND ARE SUBJECT TO ON SITE SURVEY INFORMATION.
  4. ALL PROPOSED WORKS ARE SUBJECT TO DESIGN DEVELOPMENT TO ACHIEVE APPROVAL UNDER BUILDING REGULATIONS AND OTHER SATUTORY AND LEGAL REQUIREMENTS.
  5. THIS DRAWING IS PREPARED FOR THE PURPOSE OF OBTAINING PLANNING PERMISSION ONLY.
  6. ALL DIMENSIONS IN MILLIMETRES UNLESS OTHERWISE SPECIFIED.
  7. IF IN DOUBT, ASK.

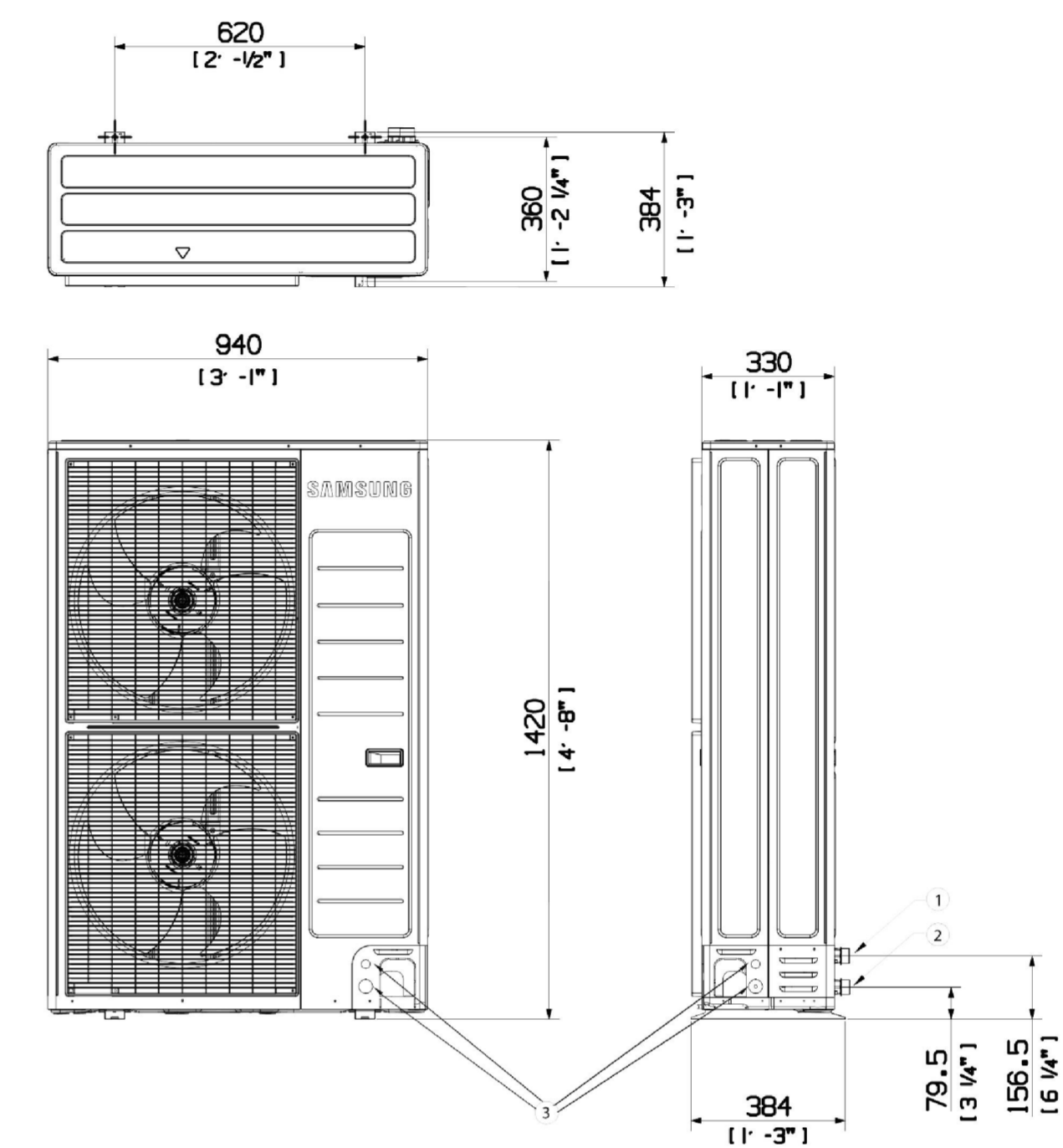

PROPOSED PERSPECTIVE A  
@ 1:25



PROPOSED ASHP DIMENSIONS

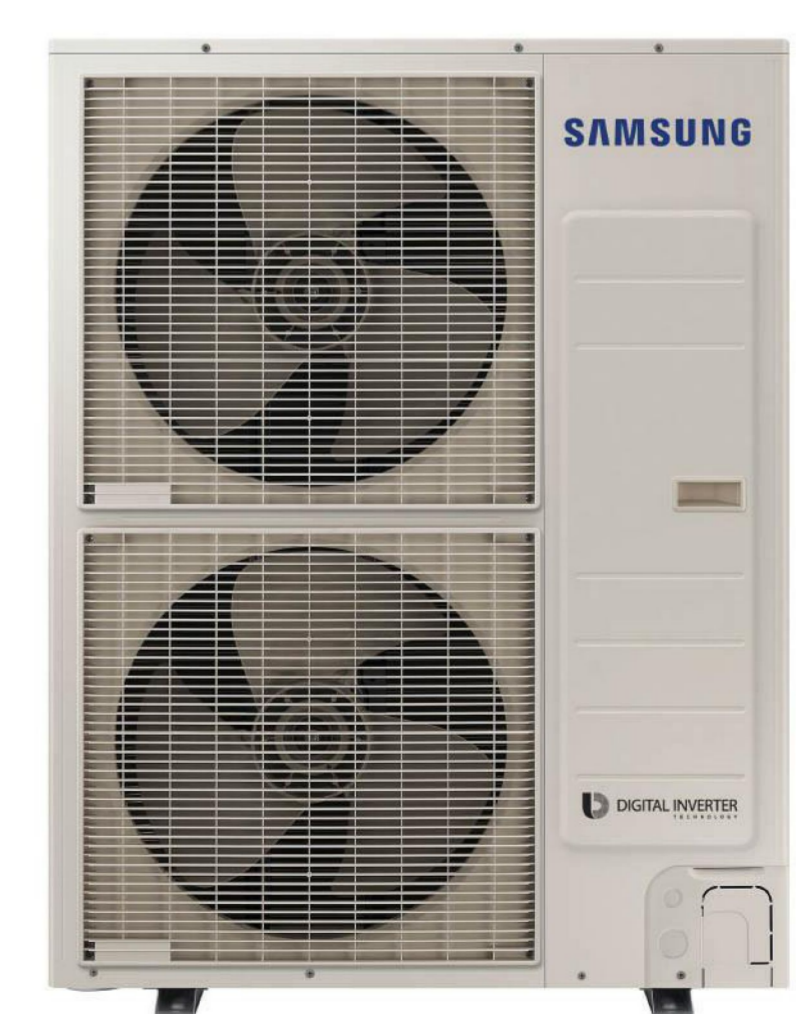

ASHP FRONT ELEVATION

REV	DESCRIPTION	DATE
A	LISTED BUILDING CONSENT	23.01.24



e. info@archhive.co      www.archhive.co      t. 0208 123 6003

PROJECT STAGE  
**LISTED BUILDING CONSENT**

PROJECT TITLE  
**LAKE HOUSE**

CLIENT  
**MR SIMON CAWTHORN**

SCALE	DRWN CR CHKD OR	TITLE
1:10		<b>PROPOSED ASHP UNITS &amp; PERSPECTIVE A</b>
	@ A1 A REV	
PROJECT NUMBER		DATE
<b>A072</b>		<b>23.01.24</b>
DRAWING NUMBER		
<b>1250</b>		