



BS5837:2012 Tree Survey  
 Land at 51 Main Street  
 Wilsford  
 Lincolnshire  
 NGR TF00217 43129

Survey by  
 Christopher Barker CEnv dipHort ACIEEM

 <a href="http://www.smasltd.com">www.smasltd.com</a> <small>as recognised by</small> 	Report prepared by: C Barker	Date Issued: 04 November 2021
	Reviewed by: KLB	Report Version: V1
	Report ref: <b>P2343 /1121 /01</b>	C B E Consulting Highbank, 5 Grantham Road, Navenby Lincoln. LN5 0JJ. Telephone (01522) 810086. <a href="http://www.cbeconsulting.co.uk">www.cbeconsulting.co.uk</a>

# BS5837 Tree Survey, Land at Main Street, Wilsford

## Contents

1. Introduction
  - 1.1 Site Description and Location
  - 1.2 Neighboring land uses
2. Tree Survey Appraisal Methodology
  - 2.1 Survey Objectives
  - 2.2 Survey Methodology
  - 2.3 Site plans and tree schedule
  - 2.4 Potential for Protected Species
3. Tree Survey Findings
  - 3.1 Survey Details
  - 3.2 Mature and Semi-Mature Trees
4. Tree Management
  - 4.1 Indicative Arboricultural Assessment
  - 4.2 Recommendations

## Appendices

Appendix 1 - Tree Survey Table

## Figures

- Figure 1 – Site Location Plan
- Figure 2 – Aerial Context Photograph
- Figure 3 – Tree Location Plan
- Figure 4 – Root Protection Area Plan

The report and the site assessments carried out by CBE Consulting on behalf of the client in accordance with the agreed terms of contract and/or written agreement were performed with the skill and care ordinarily exercised by a reasonable Environmental Consultant at the time the Services were performed. Further, and in particular, the Services were performed by CBE Consulting taking into account the limits of the scope of works required by the client, the time scale involved and the resources agreed with the client.

Other than that expressly contained in the paragraph above, CBE Consulting provides no other representation or warranty whether express or implied, in relation to the services.

This report is produced exclusively for the purposes of the client. Unless expressly provided in writing, CBE Consulting does not authorise, consent or condone any party other than the client relying upon the services provided. Any reliance on the services or any part of the services by any party other than the client is made wholly at that party's own and sole risk.

This report is based on site conditions, regulatory or other legal provisions, technology or economic conditions at the time the survey was carried out. These conditions can change with time and reliance on the findings of the survey under changing conditions should be reviewed.

CBE Consulting accepts no responsibility for the accuracy of third-party data used in this report.

# 1. Introduction

## 1.1 Site Description and Location

The site surveyed comprises a walled residential garden situated at 51 Main Street, Wilsford, Lincolnshire centred at NGR TF00217 43129. The location of the site is shown on the plan within **Figure 1** and an aerial photograph has been provided within **Figure 2** to place the site in context.

The site lies within North Kesteven and is within the designated Wilsford Conservation Area. All the trees within the area surveyed are protected under the auspices of the Conservation Area status and work cannot be carried out to these without the prior written approval of North Kesteven District Council.

In order to facilitate an application to obtain permission to develop the area surveyed the Applicant has requested a BS5837 (2012) Tree Survey should be completed to assess the quality of the trees within and close to the boundary of the field and the impact any development may have on these. An inspection of the site was completed on 25<sup>th</sup> October 2021. A photographic record of the trees at the site is included within the report.

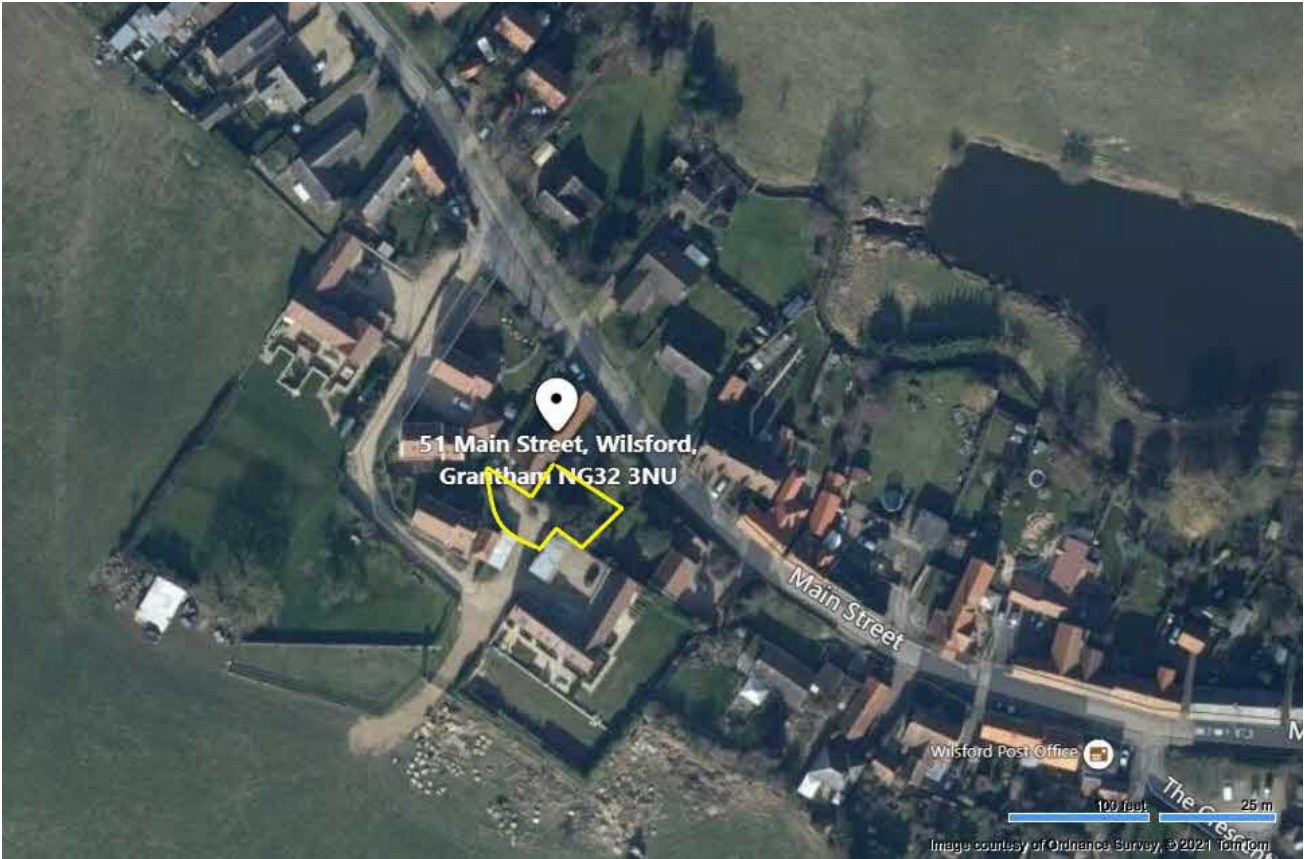

**Figure 1: Site location.**

Image copyright Microsoft Corporation 2021

## 1.2 Neighbouring Land Uses

The defined survey area is a residential garden with a stone wall around the margins and a small garden area laid to hardstanding and gravel used as a drive for parking vehicles. There are existing houses to all sides. The larger mature trees within the garden are visible from Main Street but the garden is effectively screened by a wall and shrubs. A contextual aerial photograph is provided below.



**Figure 2: Site Contextual Aerial Photograph**

Image copyright Microsoft Corporation 2021

In undertaking the tree survey the assessment has been carried out in accordance with the specifications contained within BS 5837 Trees in Relation to Design, Development and Construction (2012). An inspection of the site and the immediate surrounding areas was completed by Christopher Barker, dipHort, CEnv, an experienced arboricultural consultant.

## 2. Tree Survey Appraisal Methodology

### 2.1 Survey Objectives

This tree survey has been carried out with the objective of:

Identifying the individual tree species present at the site by means of visual inspection;

To define the approximate age, condition and canopy spread of all individual mature and semi-mature trees identified and the value of these within the development context;

To identify any trees that present a risk to existing or proposed foundations or other structures that may be constructed on the site and recommend action to remove this risk; and

Recommend tree management / mitigation measures where appropriate.

The survey broadly assessed the condition and arboricultural value of the trees lying in or adjacent to the site area, paying attention to any mature individual trees present within or adjacent to the site area in order to prepare an assessment in accordance with BS 5837 Trees in Relation to Design, Development and Construction (2012).

### 2.2 Survey Methodology

The methodology set out below is a summary of the suggested approach to tree assessment as described in British Standard 5837:2012.

Trees have been broadly assessed based on guidance set out within the British Standard BS 5837:2012 'Trees in Relation to Design, Development and Construction'. This standard provides recommendations and guidance on the principles to be applied to achieve successful integration of development with trees, shrubs and hedgerows.

Trees on the site have been divided into one of four categories (based on the cascade chart for tree quality assessment). These are classed as A, B, C or U (Section 4 of BS 5837) within the table in Appendix 1. This gives an indication as to the tree's importance in relation to the site, the local landscape and, also, the value and quality of the existing trees on site.

**Category (A):** Trees whose retention is most desirable and are of high quality and value. These trees are considered to be in such a condition as to be able to make a lasting contribution (a minimum of 40 years).

**Category (B):** Trees whose retention is considered desirable and are of moderate quality and value. These trees are considered to be in such a condition as to make a significant contribution (a minimum of 20 years).

**Category (C):** Trees that could be retained and are considered to be of low quality and value. These trees are in an adequate condition to remain until new planting could be established (a minimum of ten years) or are young trees with a stem diameter below 150 mm.

**Category (U):** Trees that are considered to have no significant landscape value but it is not presumed that there is any overriding need to remove these unless stated otherwise in the description and recommendations. These include any trees in such poor condition that they cannot be retained in the context of the current land use for more than 10 years. They are for this reason not considered as being significant within the planning process.

Species have been recorded by common and scientific name. Height has been estimated in metres and stem diameter measured in centimetres unless impractical, taken at a height of 1.5 m from the base of the tree.

The overall condition of any individual tree, or group of trees, has been referred to using one of the definitions listed below. A more detailed description of condition has been noted in the Tree Schedule.

- G **Good:** A sound tree or trees needing little, if any, attention
- F **Fair:** A tree or trees with minor but rectifiable defects or in the early stages of stress, from which it may recover
- P **Poor:** A tree or trees with major structural and physiological defects or stressed such that it would be very expensive and inappropriate to retain
- D **Dead:** A tree or trees no longer alive. However, this could also apply to those trees that are dying and will be unlikely to recover, or are becoming or have become dangerous

The survey was completed from ground level only. Aerial inspections were not undertaken. Evaluations of tree conditions given within this assessment apply to the date of survey and cannot be assumed to remain unchanged, and it may be necessary to review these within 24 months, in accordance with good arboricultural practice.

### 2.3 Site Plans & Tree schedules

The position of significant individual trees or groups of trees measured out on the site is shown on the Tree Location Plan **Figure 3**. Within the summary table (**Appendix 1**) a calculated corresponding radius of the circle for each RPA has been calculated. The Root Protection Areas are formulated to assist when designing layouts in relation to trees and the calculated RPAs in Appendix 1 should be used to inform the design layout of this site. A proposed development plan has been provided and this has been used to show the impact on the trees within **Figure 4**.

### 3. Tree Survey Findings

#### 3.1 Survey Details

The tree inspection took the form of a walkover inspection completed by Christopher Barker dipHort, CEnv. Each individual semi-mature or mature tree of significance that could be impacted by any proposed new development within the survey area was identified, visually inspected and classified. The character of the trees at the site is shown in photographs contained within this section.

#### 3.2 Mature and Semi-Mature Trees

A total of six individual trees have been identified and assessed as part of the tree survey.

**Tress T1 and T2** comprises a small Holly and a large Box situated within the walled garden. These are not specimens of high landscape value in this position and the Box has not been trimmed. Holly T1 is placed into Category C and Box T2 is placed into Category U.



Holly T1 and Box T2

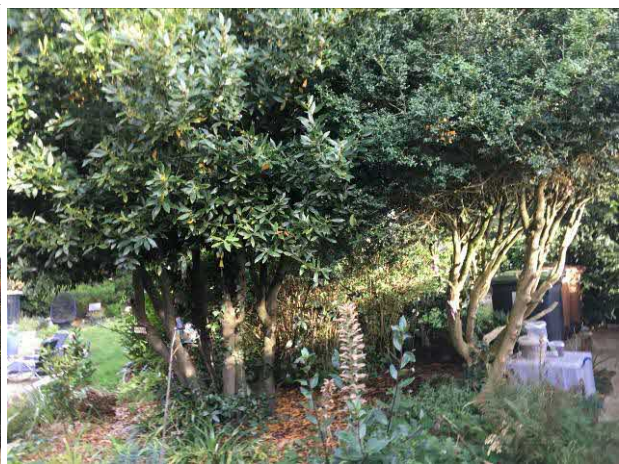

Trunks of T1 (left) and T2 (right)

**Yew T3 and Horse Chestnut T4** are large mature trees in the garden and the merging crowns of these tree dominate the position and can be seen from Main Street. The Yew is in good condition, crowded by the nearby Horse Chestnut but of sufficient quality to be placed into Category B. The Horse Chestnut is confined by the Yew and the property to the south, the crown extending across the edge of the roof of this property. There is no evidence of canker and the tree is placed within Category B.



Yew T3 (right) and Horse Chestnut T4 (left)

**Damson T5 and T6** are in the rear driveway area of the property outside of the walled garden. Both are small tree, hidden from view except from the south. Damson T5 is placed into category C and this tree will need to be removed to facilitate the proposed garage development. Damson T5 can be retained but there is a significant wound and decay in the main trunk of this small tree so this should be monitored. This tree is placed into Category U.



Damson T6



Damson T5



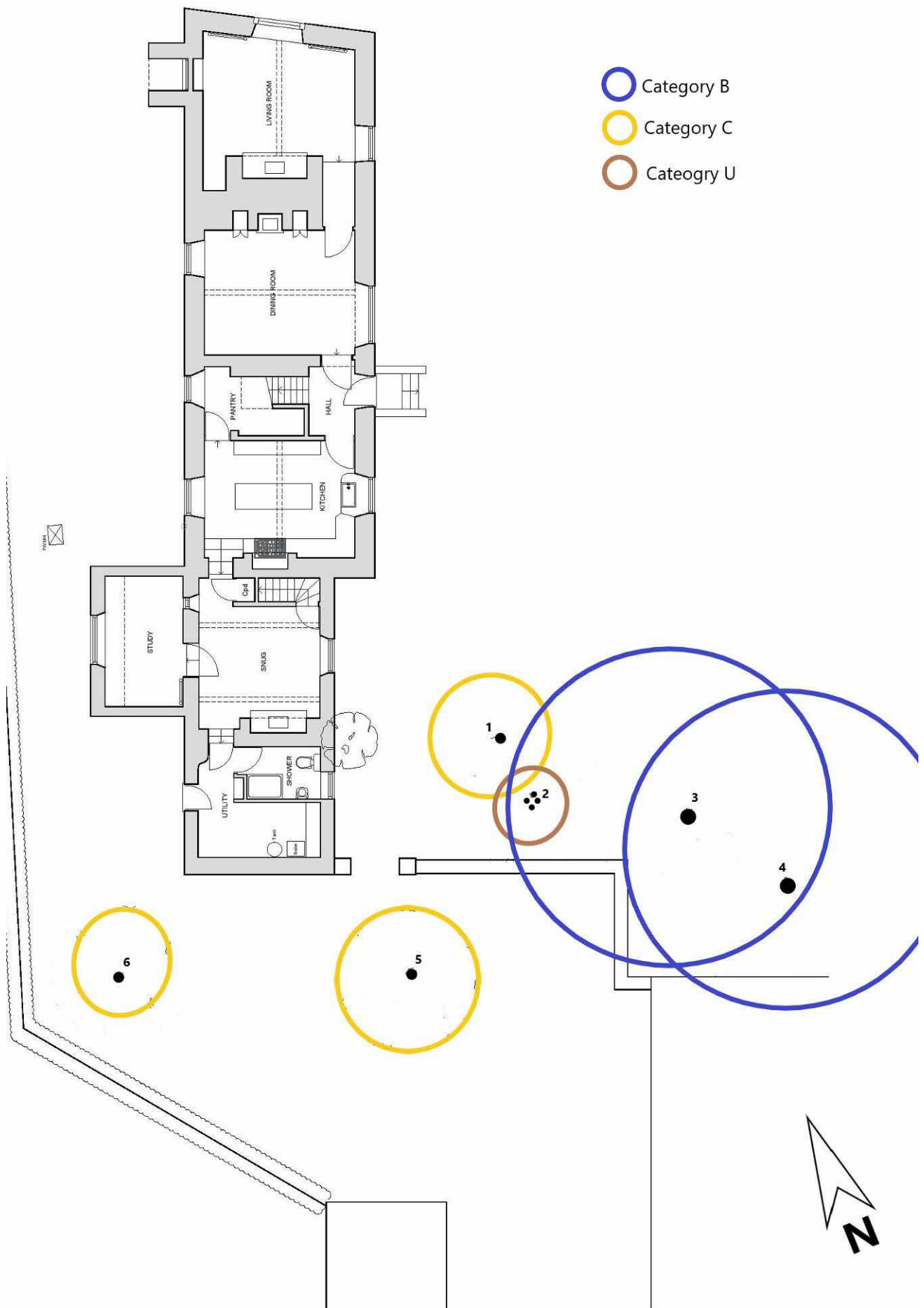

Figure 3 – Tree Category Plan

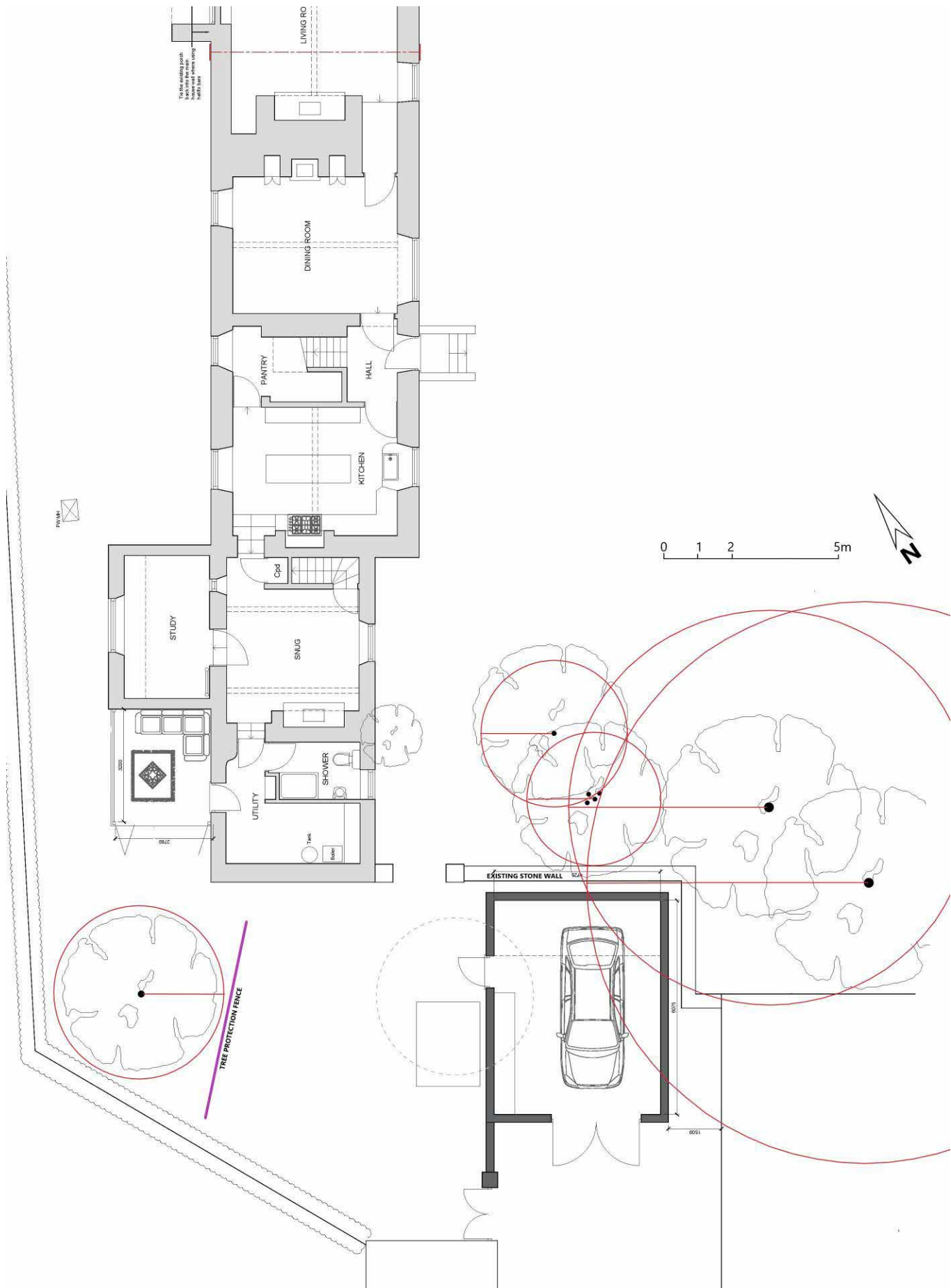

Figure 4 – Root Protection Area Plan

## 4. Tree Management

### 4.1 Initial Arboricultural Assessment

In the context of this site the proposed development will comprise a garage to be constructed outside of the walled garden area as shown within **Figure 4**. The table below summarises the potential impact of the proposed development on the trees present within the area surveyed.

Tree	Category	Impact of development
T1 Holly	C2	None. RPA and crown are outside of the construction area behind a stone wall
T2 Box	U	None. RPA and crown are outside of the construction area behind a stone wall
T3 Yew	B2	Minor loss of calculated RPA under the foundation of the garage. The rooting to the south is likely to be restricted by the stone wall and the nearby house so significant impact is very unlikely.
T4 Horse Chestnut	B2	Minor loss of calculated RPA under the foundation of the garage. The rooting to the south is likely to be restricted by the stone wall and the nearby house so significant impact is very unlikely.
T5 Damson	C2	This tree will have to be removed to facilitate the construction of the garage.
T6 Damson	U	None. RPA and crown are outside of the construction area and can be entirely protected by fencing.

Only one tree will need to be removed to facilitate the construction of the garage, three others not being impacted at all.

Theoretically there may be some loss of rooting area for trees T3 and T4 from the garage. However, there are factors to take into consideration which may have restricted rooting in this specific location:

- a) This is an area of existing gravel hardstanding which is being used for vehicular traffic, and
- b) There is an existing stone garden wall with a reasonable foundation between the trees and the proposed position of the garage.

It is still possible that there will be tree roots from T3 and T4 in the area where the garage is proposed and therefore it is recommended that a foundation solution is used which incorporates mini-piles and a raft to avoid the need for significant excavation in this area. It is more likely that the majority of the roots for Yew T3 will extend to the north rather than the south due to the position of Horse Chestnut T4. The roots of this latter tree are likely to extend west and north east where there will be plenty of space but the house to the south and the wall will be barriers that the majority of the roots are likely to follow.

If the garage is constructed in a sympathetic manner which avoid any excavation of foundations then the potential loss of rooting to T3 and T4 is likely to be very small and significant impact on the vitality of these trees should be avoided. There is no conflict with the crowns or any low branches.

### 4.2 General Recommendations

The trees in the garden and near to the garage that are being retained will need to be adequately protected during any approved development works where the canopies or calculated root protection areas extend across the field boundary. As a general rule at this site, measures to protect trees should follow the best practice principles set out in BS5837: Trees in Relation to Design, Development and Construction (2012). Prior to any construction or development work proceeding,

the RPAs of individual trees to be retained should be marked out using the distances provided in the table within Appendix 1.

Marking out should be completed by a person with arboricultural or horticultural expertise as individual trees will have root zones that may be affected by local conditions and allowances will need to be made to accommodate this. The best practice principles have been broadly summarised below.

All trees retained adjacent to the site should be protected by barriers or ground protection around the calculated Root Protection Area (RPA) and as indicated on any Tree Constraints Plan (TCP) that may be produced in association with the assessment.

Any fencing required should be erected prior to commencement of construction and before demolition including erection of any temporary structures. Once set up fences should not be removed or altered without prior consultation with the arboricultural advisor.

Arrangements should be made for an arboriculturalist to supervise works and tree protection where trees are particularly vulnerable or sited close to access points.

Pre-development works may be undertaken prior to the installation of fencing with the agreement of the local planning authority.

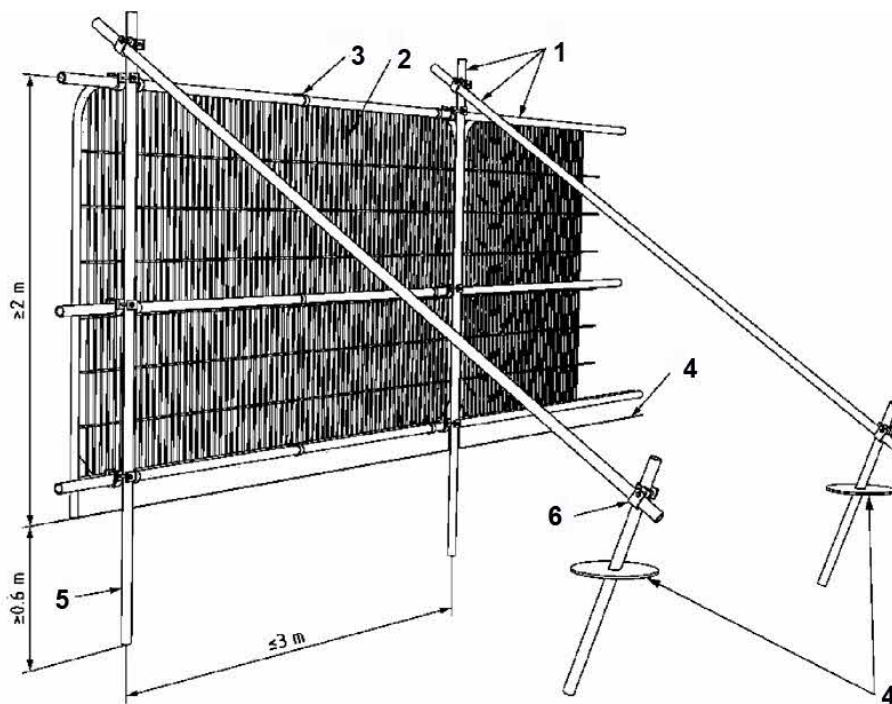

1. Standard scaffold poles
2. Heavy Gauge 2m tall galvanized tube and weld mesh infill panels
3. Panels secured to uprights and cross members with wire ties
4. Ground Level
5. Uprights driven into ground until secure (up to 0.6m)
6. Standard scaffold clamps

All tree works should follow best practice procedures as set out in BS 3998 (2010). All trees should be maintained in good condition on site and be inspected annually (where overall condition requires) or every 2 years and after any major storm events, with safety a priority.

- Fencing should be clearly visible and suitable for the location, type and proximity of construction activity.
- Where it has been agreed and shown on a Tree Protection Plan, construction access may take place within the RPA if suitable ground protection measures are in place (e.g. existing surfaced car park areas). In other areas this may comprise single scaffold boards over a compressible layer laid onto geo-textile materials for pedestrian movements. Vehicular movements over the RPA will require the calculation of expected loading and may require the use of proprietary protection systems.
- Once areas around trees have been protected by fencing, any works on the remaining site area may be commenced providing activities do not impinge on protected areas. Notices should be placed on fencing to indicate that operations are not permitted within the fenced area.
- Wide or tall loads etc. should not come into contact with retained trees. Banksman should supervise transit of vehicles, jibs, booms etc. where this is in close proximity to retained trees.
- Oil, bitumen, cement or other material that is potentially injurious to trees should not be stacked or discharged within 10m of a tree bole. No concrete mixing should be done within 10m of a tree. Allowance should be made for the slope of ground to prevent materials running towards the tree.
- No fires will be lit where flames are anticipated to extend to within 5m of tree foliage, branches or trunk, taking into consideration wind direction and size of fire.
- Notice boards, telephone cables or other services should not be attached to any part of a retained tree.
- Where it is deemed necessary to operate a wide or tall load, plant bearing booms, jibs and counterweights or other such equipment, as part of construction works, and such equipment would have potential to cause injurious contact with crown material i.e. low branches and limbs, of retained trees within the RPA fencing, it is best advised that appropriate, but limited tree surgery, be carried out beforehand to remove any obvious problem branches. This is classed as 'Facilitation Pruning' within BS 5837 (2012). Any such pruning should be undertaken in accordance with a specification prepared by an arboriculturalist.
- It is advised that a Pre-Commencement Site Meeting is held with contractors who are responsible for operating machinery, as described above. To firstly highlight the potential for damage occurring to tree crowns and to ensure that extra care is applied when manoeuvring machinery during such operations within close proximity to retained trees to avoid any contact.
- In the event of having caused any such branch or limb damage to retained trees it is strongly recommended that suitable tree surgery be carried out, in accordance with BS 3998 (2010) Recommendations for Tree Work, to correct the damage, upon completion of development.



Christopher Barker CEnv dipHort

## Appendix 1: BS5837 Tree Schedule

Key:	Measurements	Age – Class	Overall Condition	BS 5837 2012 : Cascade Chart for Quality Assessment/Retention Category	Symbols:
	MS – Multi-stemmed	YNG-MAT-Young Mature	G – Good	A – High	< = less than
	Ht - Height in metres	SM – Semi-mature	F – Fair	B – Moderate	~ = approximately
	Stem – Stem Diameter at 1.5m in mm	Mat – Mature	P – Poor	C – Low	> = greater than
	Crown – Crown spread in metres	OM – Over mature	D – Dead	U – Trees of negligible significance	
	TD - Trunk division (height in metres)	<b>Est Yrs</b> – estimate of years remaining (>40 years; 20 –40 years; <20 years)		<b>Sub-categories:</b> 1 = mainly arboricultural values 2 = mainly landscape values 3 = mainly cultural values.	

RPA = Root protection area (equivalent to a circle with a radius 12 x the stem diameter for single stem trees and 10 x the basal diameter for trees with more than one stem arising below 1.5m above ground level).

Tree No	Species	Ht (m)	Stem Diam mm@ 1.5m	Canopy Spread (m)	Height of Crown Clearance	Age Class	Est yrs	Overall Condition	Structural condition	Recommendations	BS 5837 Category	RPA Radius (m)
T1	Holly <i>Ilex aquifolium</i>	6	3 X 100 4 X 50	N-2 S-2 E-2 W-2	2	M	10+	G	Multiple trunks from coppice. Dense, trimmed round crown which has been lifted. No structural faults visible from ground level	None	C2	2.2
T2	Box <i>Buxus sempervivens</i>	3	70 50 40	N-2 S-1 E-1 W-1	1	M	10	F	Untrimmed shrubby Box which has been crown lifted. No structural faults visible from ground level	Coppice and allow to regenerate as a small shrub.	U	1.8
T3	Yew <i>Taxus baccata</i>	9	350 330	N-4 S-5 E-6 W-4	1	M	20+	G	Two trunks. Irregular crown extending north east with ivy cover on the trunk. Heavier on the east side. No structural faults visible from ground level	Remove ivy cover on trunk.	B2	5.7
T4	Horse Chestnut <i>Aesculus hippocastenum</i>	10	680	N-6 S-3 E-6 W-5	5	M	20+	G	Single trunk with ivy cover. Basal regeneration present. Board balanced crown has been lifted, extending over the ridge of the adjacent property. No structural faults visible from ground level	Remove ivy cover and basal regeneration.	B2	8.1
T5	Damson <i>Prunus domestica</i>	5	210	N-3 S-3 E-2 W-2	2	SM	10+	G	Single trunk leans to the north supporting a round irregular crown with a nest present. No structural faults visible from ground level	None	C2	2.5

Tree No	Species	Ht (m)	Stem Diam mm@ 1.5m	Canopy Spread (m)	Height of Crown Clearance	Age Class	Est yrs	Overall Condition	Structural condition	Recommendations	BS 5837 Category	RPA Radius (m)
T6	Damson <i>Prunus domestica</i>	4	205	N-2 S-2 E-1 W-2	3	SM	<10	P	Single trunk with large deep split at 1magl showing evidence of decay in the trunk interior. Flat topped, lifted crown. No structural faults visible from ground level	None	U	2.4