

Site Layout Plan. 1:250

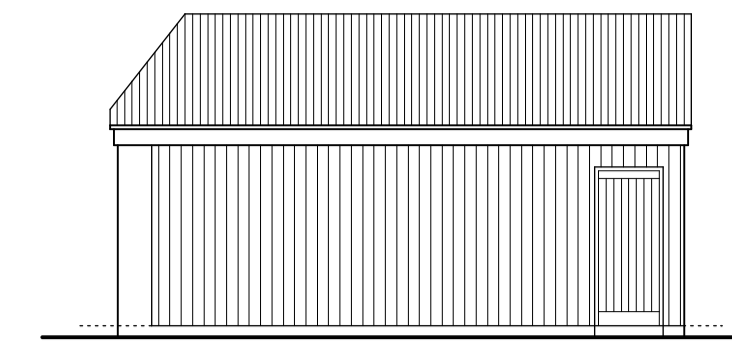

North Elevation. 1:100

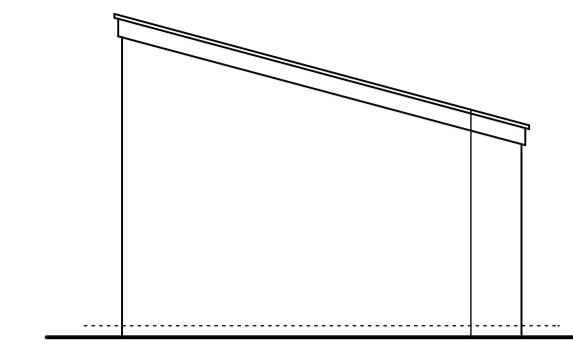

East Elevation. 1:100

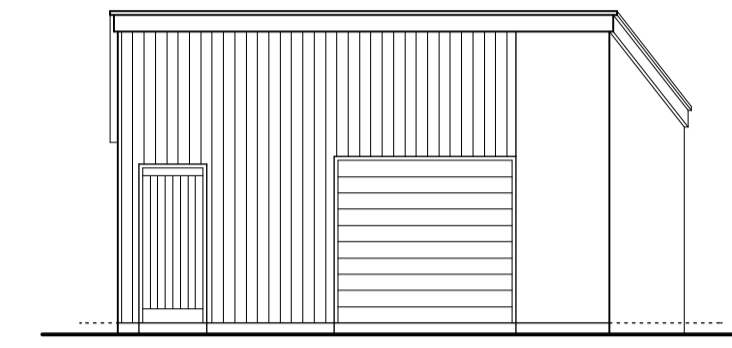

South Elevation. 1:100

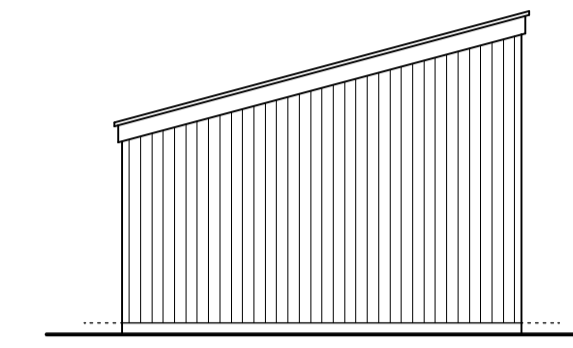

West Elevation. 1:100

**Garage Elevations**

**Proposed Finishes**

House	
Walls	Wet Dash Harl Vertical Timber Linings
Roof	Slates
Windows	Timber - Painted White
External Doors	Timber - Painted White
Garage	
Walls	Wet Dash Harl Vertical Timber Linings
Roof	Profiled Metal Sheeting
Garage Door	Metal Up-and-Over - White
Pedestrian Door	Timber - Painted White

No	Revisions	Date	Initials
A	Levels Added	23.01.24	MR

**MANTELL  
RITCHIE**

Chartered Architects

27A High Street, BANFF,  
AB45 1AN  
Tel: 01261 812267  
Email: admin@mantellritchie.co.uk  
www.mantellritchie.com



Copyright of Mantell Ritchie, Chartered Architect.

project  
**188 Seatown,  
CULLEN.**  
Replacement House  
for  
**Mr + Mrs D Pritchard**

content  
Site Layout Plan and Garage Elevations

scales		
1:100	1:250	
drawn by	size	date
MR	A1	04.01.24

ref **21170** **09A**