

ELEVATION 1:20

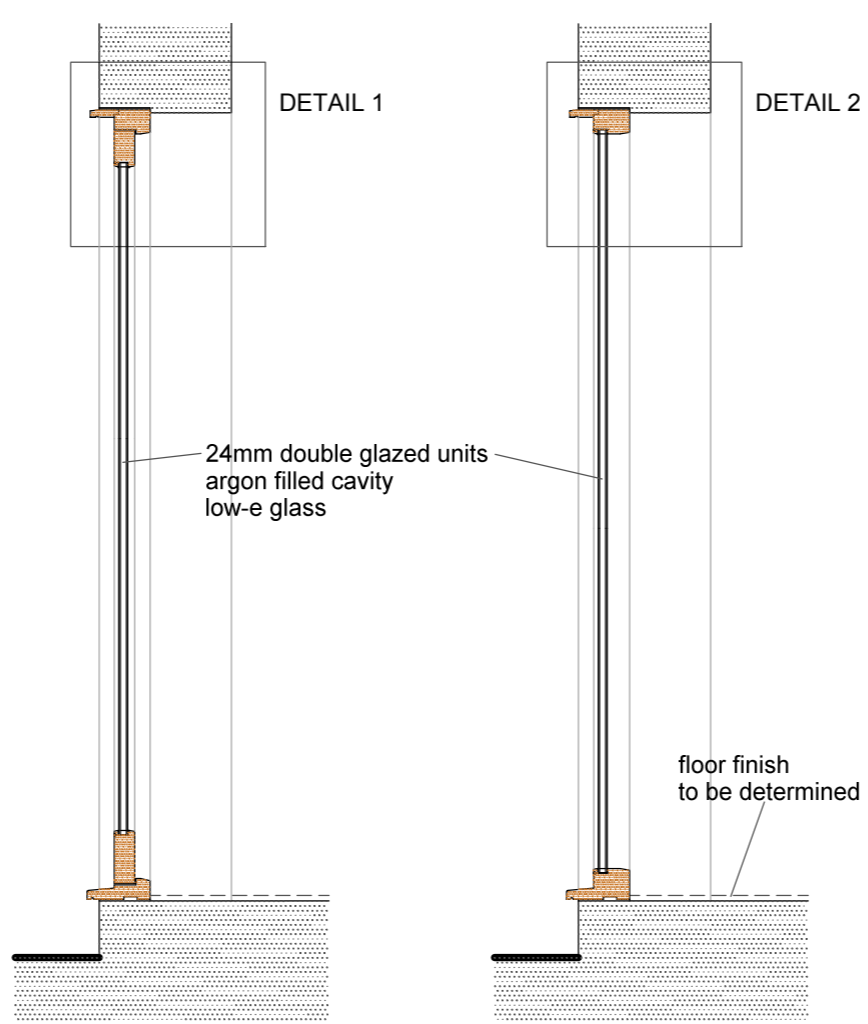

SECTION 1:20

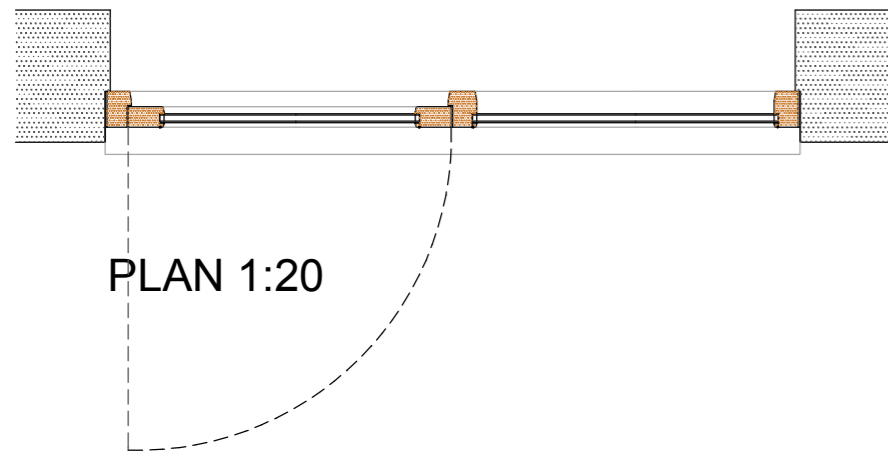

PLAN 1:20

Frames to be constructed in hardwood, vac treated, with stain finish, colour 'dark cherry' to match existing joinery. All glazing below 800mm above floor level to be toughened safety glass. Windows to achieve u-value of 1.6 or better. Internal hardware to be polished brass.

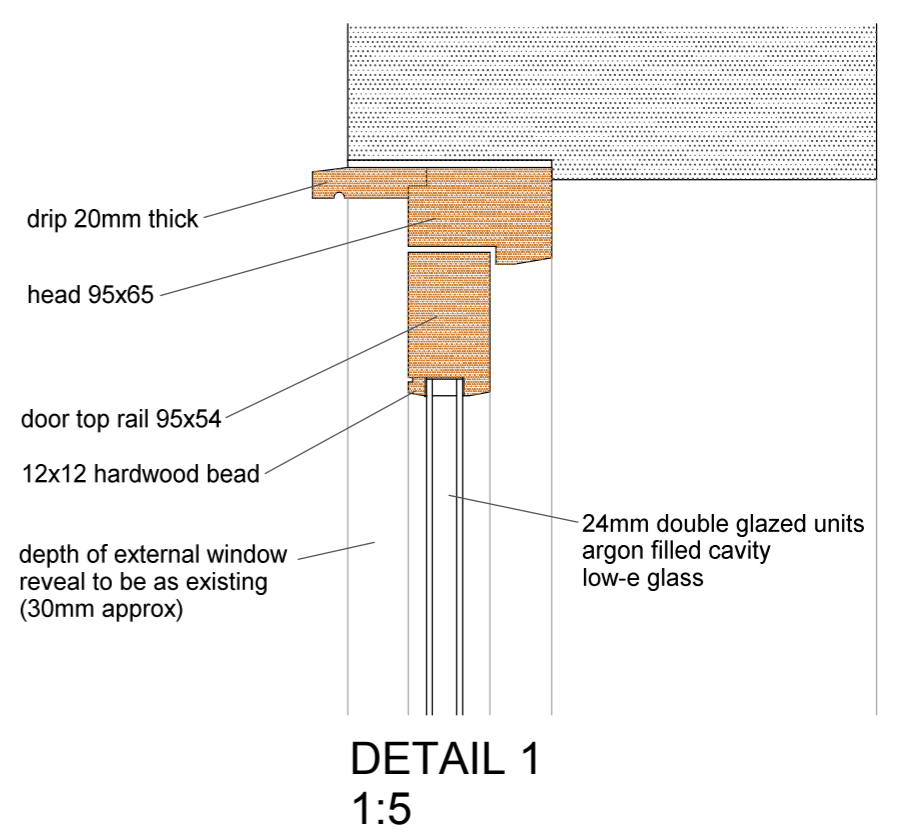

DETAIL 1 1:5

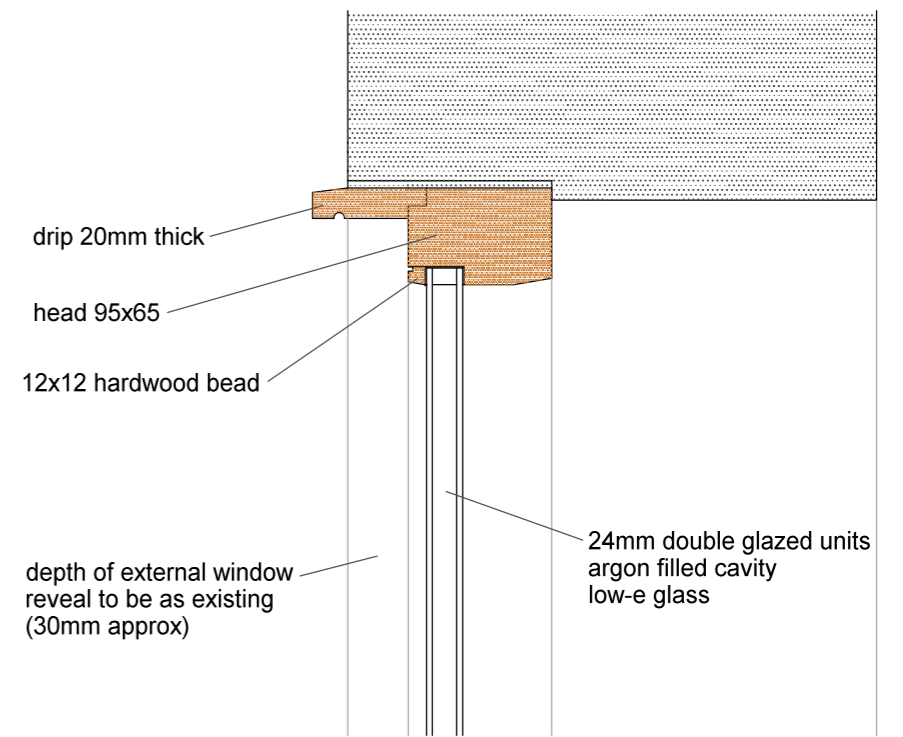

DETAIL 2 1:5



www.heeleysarchitects.co.uk

**Client**  
Ms V Nixon

**Project**  
The Saddlery  
Hall Farm  
Hadnall

**Proposed**  
Door details 1:20, 1:5

**Date** 30-01-24

**Drawing No.** 2321 - 4

# DOOR DETAILS - D1