

30 X 5mm METAL STRAPS WITH SOLID  
TIMBER BLOCKS BETWEEN JOISTS &  
CROSS NAILED

ALL TIMBER TO TIMBER CONNECTION TO BE  
MADE USING METAL FRAMING ANCHOR CLIPS  
& 8mm BOLTS (UNO)

ALL DOUBLED UP JOISTS & POSTS TO BE WITH  
8mm BOLTS @ 400CRS STAGGERED  
NEW TIMBER FLOOR SEE SPECIFICATION FOR  
DETAILS. TO BE PROVIDED OVER ENTIRE ROOF  
SPACE.

NEW SOLID TIMBER BLOCK TO SUIT ON SITE  
TO BE PROVIDED EXISTING CEILING JOIST &  
CROSS NAILED

ALL FLOOR BEAM TO BEAM CONNECTIONS  
TO BE MADE USING 10mm THICK END PLATE  
WITH 4 No 16mm 8.8 BOLTS & 6mm FILLET  
WELDS.

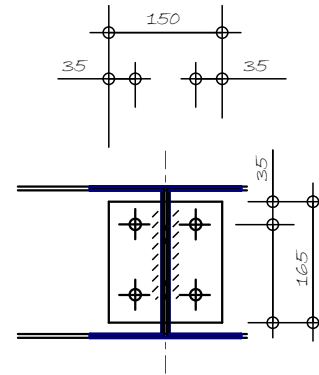

DETAIL 8

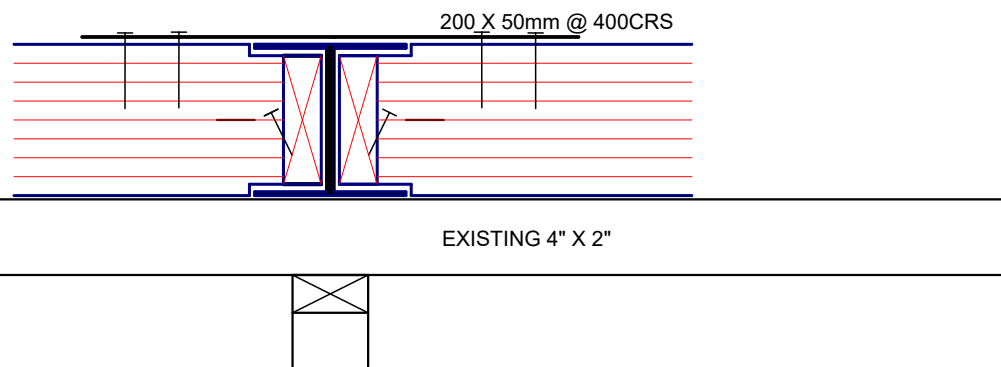
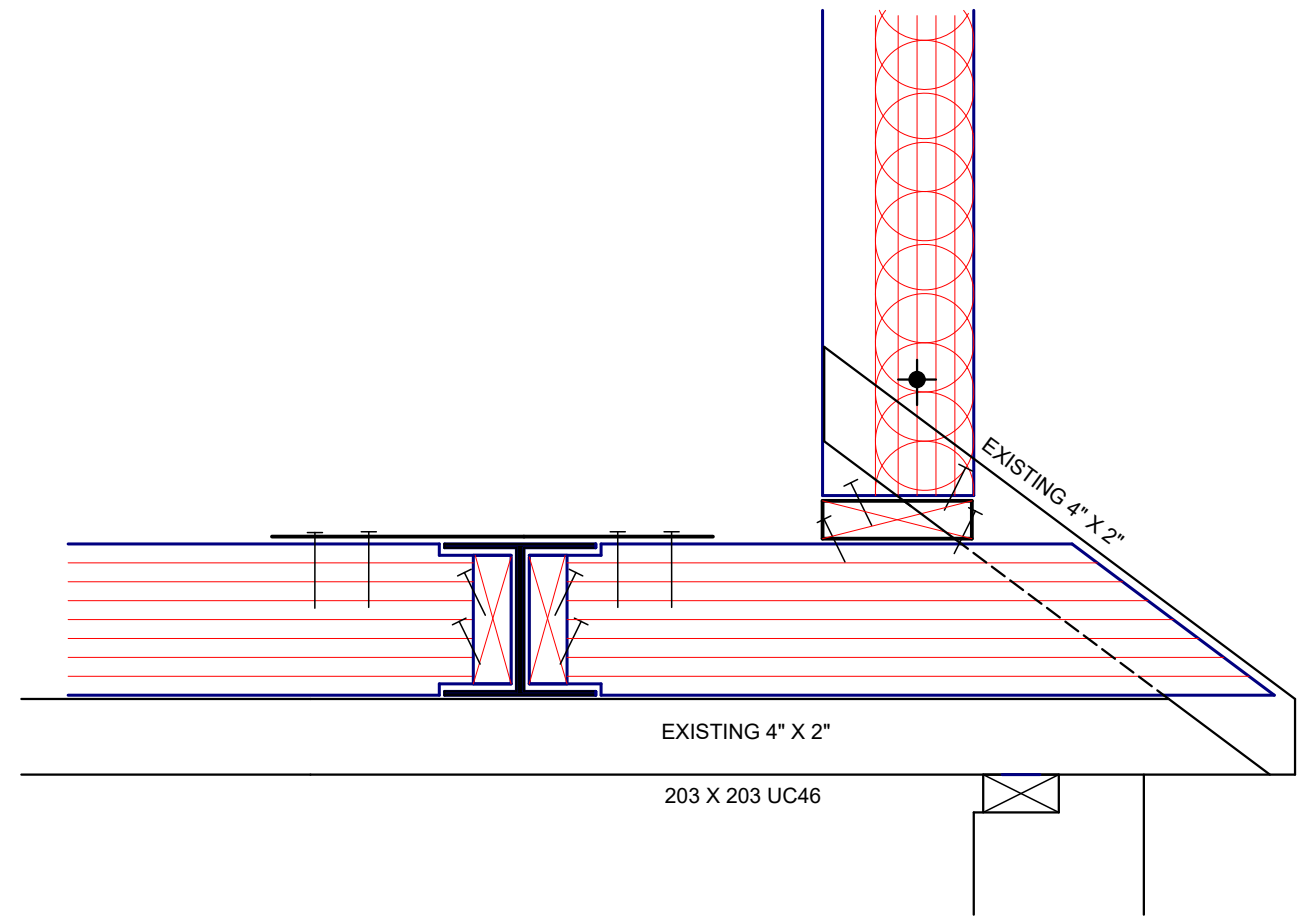

SECTION B B 1:10

OWNER

MR & MRS NICHOLSON □

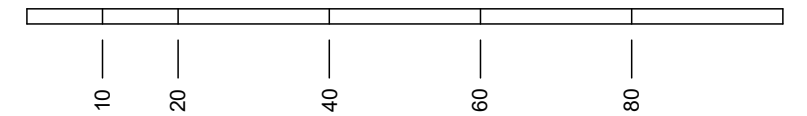

SITE

8 CHERRY TREE ROAD  
N29QL

PROPOSED SINGLE STOREY REAR  
EXTENSION & LOFT CONVERSION

DRAWING No

06/07B 24/0236/HSE

DATE

SCALE

1:10 A3