

**Notes:**

1. Tanks have an inlet invert depth of 1.0m. Upon request tanks may have an invert depth of 1.5m. Do not extend the tank neck.
2. This drawing should be used for dimensional information only. Refer to installation guidelines.
3. Additional ventilation can be achieved on the incoming drain, via a stack pipe. Position to suit specific site conditions.
4. Confirm with local building regulations if additional venting is required.

Capacity Litres	Dimensions					Cover & Frame
	A' Ø	B'	C'	D'	E'	
2800	2075	1599	1549	2599	1520	CFL460E
3800	2075	1819	1769	2810	1740	CFL460E
4600	2084	1984	1934	2984	1905	CFL460E

**Roding & Cleaning Access On Pedestrian Duty Manhole Cover**

Pea Shingle / Soil

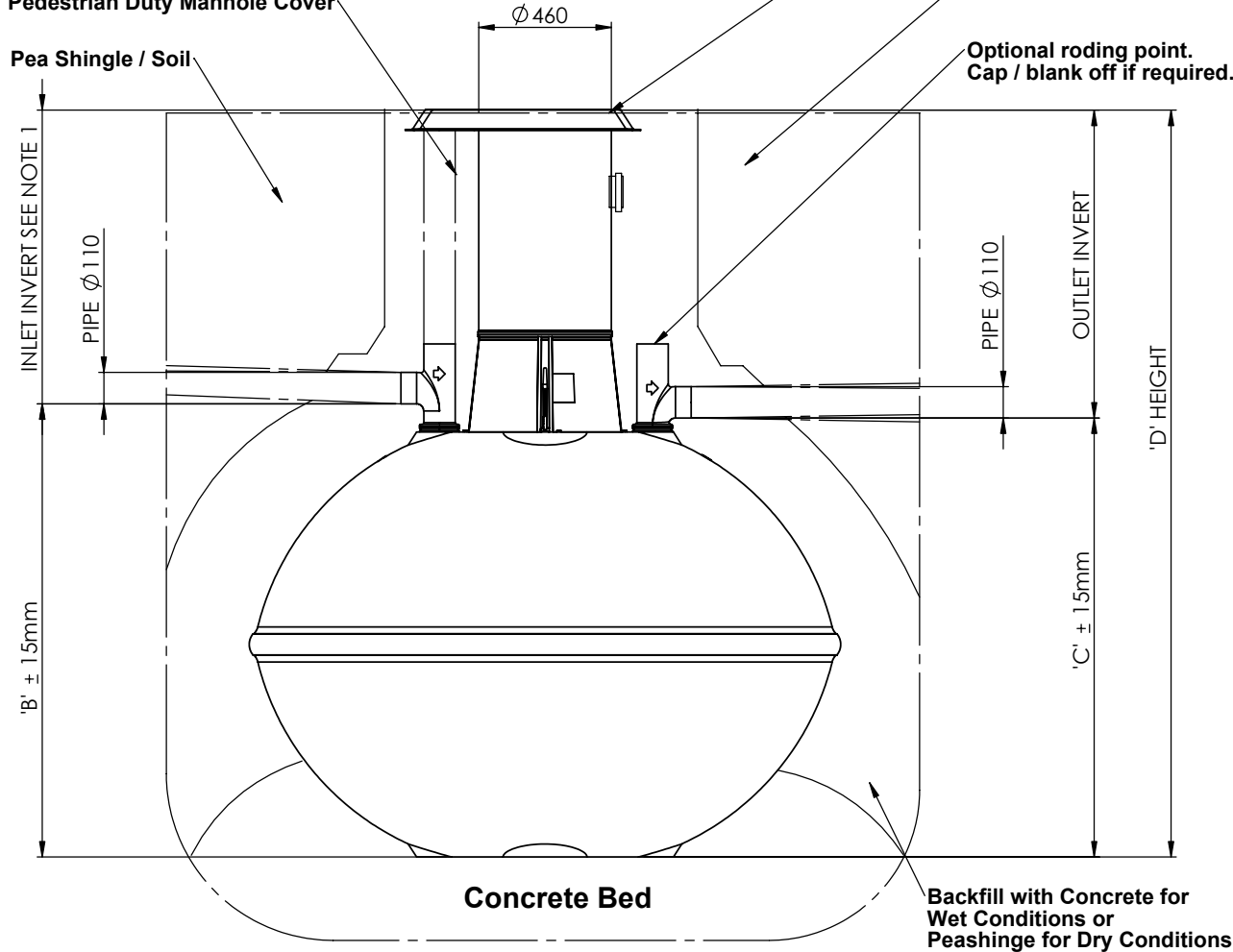

**Alternative Vent Connection**

**M12 Lifting Eyes**

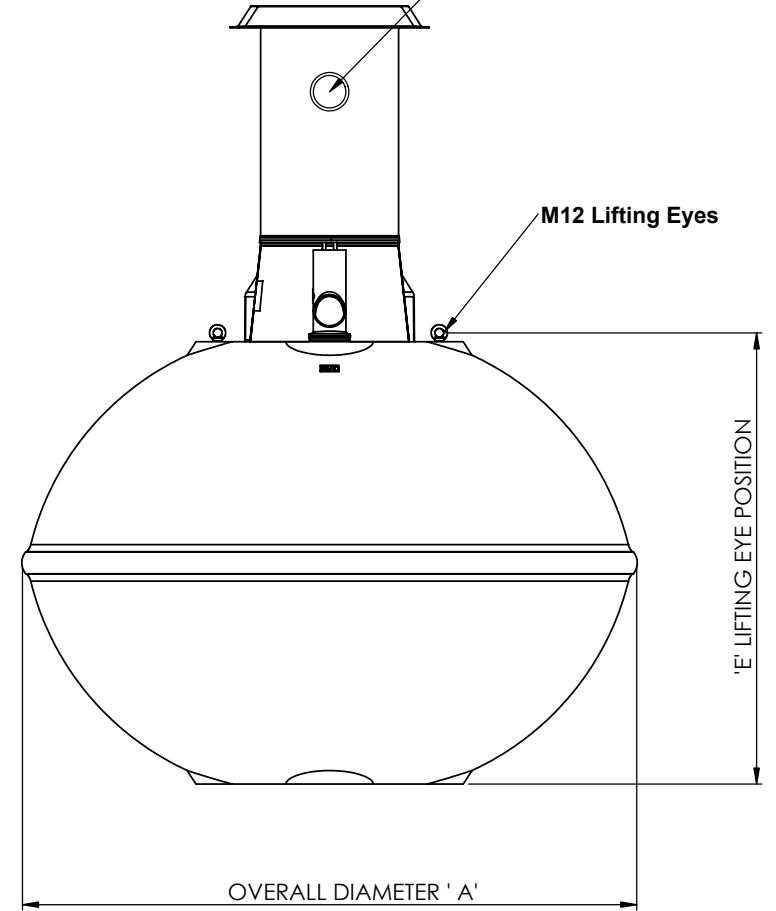

Please Check with Environmental Treatment Systems Limited For The Latest Issue Of This Drawing

Issue	Date	Drawn by	Approved by	Description
03	09.08.12	JC		CC1070
02	25.03.12	CS		CC1014 - Rota-moulded Inlet & Outlet Pipes Introduced.
01	05.02.09	JC		CC682

Material :	Tolerance (unless stated) :
Finish :	Thickness :
Weight :	Surface Area : m <sup>2</sup>
Modelled By :	

**Drawing : DS0552P**

Page 1 of 1

2800, 3800 & 4600 LITRE ALPHA SEPTIC TANKS

All Dimensions In mm

Scale: Do Not Scale

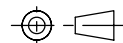

Third Angle Projection

Kingspan Environmental reserve the right to alter the details of this drawing without prior notice. This drawing is copyright and may not be reproduced or used without the written permission of Kingspan Environmental

