



**VALLIS & HALL**  
CONSERVATION ARCHITECTS

**Construction Method Statement in relation to Arboriculture on site  
to BS 5837: 2012, *Trees in relation to design, demolition and construction***

Single storey timber-framed two-bay parking garage building with single bay store.



St Peter's Well,  
Vicarage Lane,  
Lodsworth  
West Sussex  
GU28 09DF

For

Mr & Mrs P Nash

December 2023

<b>CONTENTS</b>	<b>Page No.</b>
1 - Introduction	3
2 – Tree works prior, during & post construction	4
3 – The protective barrier prior, during & post construction	5
4 – Construction phase	9
Appendices	10 - 15

## I. Introduction

### I.1. Purpose of the Method Statement

I.1.1. This method statement has been prepared to ensure good practice in the protection of trees during the proposed garage development at St Peters Well, Vicarage Lane, Lodsworth.

### I.2. Terms of Reference

I.2.1. This report conforms to the most recent specifications outlined in BS 5837:2012 *Trees in relation to design, demolition and construction – Recommendations*.

I.2.2. It is proposed to construct a new single storey two-bay timber-framed garage building with side store to the far south-east corner of the site at St. Peter's Well to improve the existing access and exit of vehicles from the property, conceal the vehicles from view of the Lane to the east side and provide security to the site.

### I.3. Status the

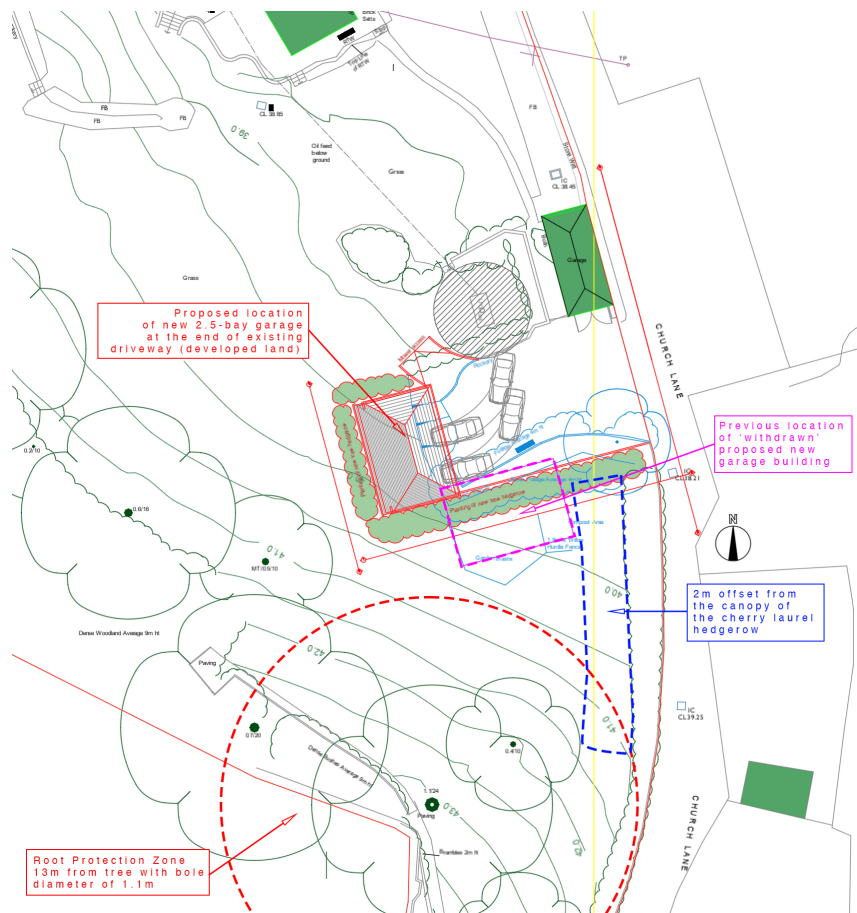

### Method Statement

I.3.1. This Method Statement should be included as part of the specification and schedule of works issued to the building contractor.

I.3.2. This Method Statement should be available on site for inspection by the Local Authority, contractors and other relevant persons once approved.

#### 1.4. Tree schedule (photographic)



Image left: (red) Existing low quality scrub and brambles to be removed and replanted with yew hedging and (blue) low quality grass and weeds to the end of the hard landscaped driveway to be removed for proposed garage base.

## 2. Tree works prior, during and post construction

### 2.1. Tree works prior to construction

- 2.1.1. Prior to any construction activity, the first operation on site will be the undertaking of any necessary arboricultural works to trees and overgrown hedgerows. All tree works must be carried out in accordance with BS 3998:2010 – *Recommendations for tree work*.
- 2.1.2. Any tree works required to assist the development must not be carried out until prior approval has been granted by the Local Planning Authority, as necessary.

### 2.2. Tree works during construction

- 2.2.1. Damage to trees, to the southern side of the proposed new garage building, during the construction phase should be entirely prevented by the erection of a temporary protective barrier, to create a Construction Exclusion Zone (CEZ).
- 2.2.2. Damage to the cherry laurel hedgrow, along the east boundary, during the construction phase should be entirely prevented by the erection of a temporary protective barrier to create a Construction Exclusion Zone (CEZ).
- 2.2.3. Also, the special measures explained within this report which detail other protection measures to be taken, prior to, during and post construction.
- 2.2.4. All persons on site must be aware of limitations that apply within the CEZ (please refer to section 3)
- 2.2.5. If damage is caused to the protected trees it must be immediately reported to a qualified Arboricultural specialist to agree on appropriate remedial action.

### **2.3. Tree works post construction**

- 2.3.1. When the construction works are completed and protective barrier have been removed some minor remedial works may be required. This may be for aesthetic purposes; to give clearance or simply to remove any hanging or damaged branches.
- 2.3.2. No post construction remedial works are to be carried out on the trees until prior approval has been granted by the Local Planning Authority, as necessary.

### **2.4. Recommendations for tree works**

- 2.4.1. All work must be to BS 3998:2010 – *Recommendations for tree work* and should be carried out by qualified, experienced and, ideally, Arboricultural Association approved contractors who should be adequately insured.
- 2.4.2. Any defects seen by a contractor or client that were not apparent prior to the construction works must be brought to the attention of an Arboricultural specialist immediately.
- 2.4.3. Any works to trees or vegetation clearance should only be undertaken outside of the bird breeding season, which takes place between 1<sup>st</sup> March ' 1<sup>st</sup> October. If works are required within this time an ecologist will need to check the site before any works take place (within 24hours of any work).

## **3. The protective barrier prior, during and post construction**

### **3.1. Protective barrier prior to construction**

- 3.1.1. The installation of the temporary protective barrier will be the very first job to be undertaken on site following completion of any enabling tree works.
- 3.1.2. No other work including soil stripping, excavation, or the bringing onto site of materials or machinery, shall commence until the barrier is installed, inspected and approved by the Local Authority.

3.1.3. The protective barrier must be constructed in accordance with BS 5837: 2012 *Trees in relation to design, demolition and construction – Recommendations* and should be located as shown on the tree protection plan attached below and in Appendix 1.

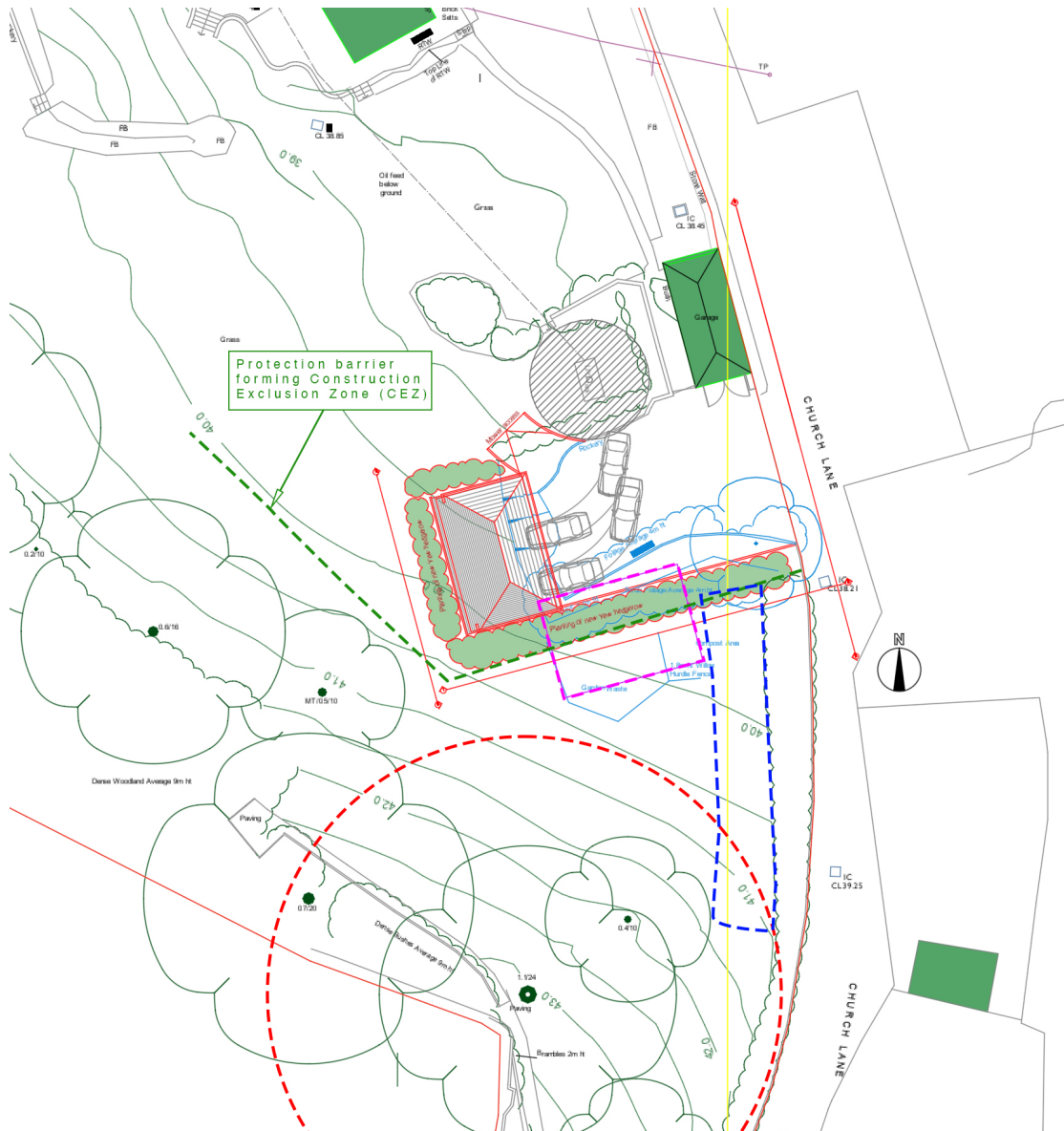

3.1.4. The protective barrier will be appropriate to the degree and proximity of likely construction works. The default specifications of BS 5837: 2012 recommends a vertical and horizontal, scaffold framework, well braced to resist impacts. The vertical tubes should be spaced at a maximum of 3m intervals and driven securely into the ground, taking care to avoid underground services and structural roots. Finally welded mesh panels (heras fencing) are to be securely fixed to the scaffold framework. Please refer to the Appendix 2 for the protective barrier details and examples of ground fixing, *image below for reference of BS 5837: 2012 as stated above.*

3.1.5. Please see appendix 2 for alternative above ground stabilisation systems.



### Tree Protection Fencing in Accordance with BS5837:2012

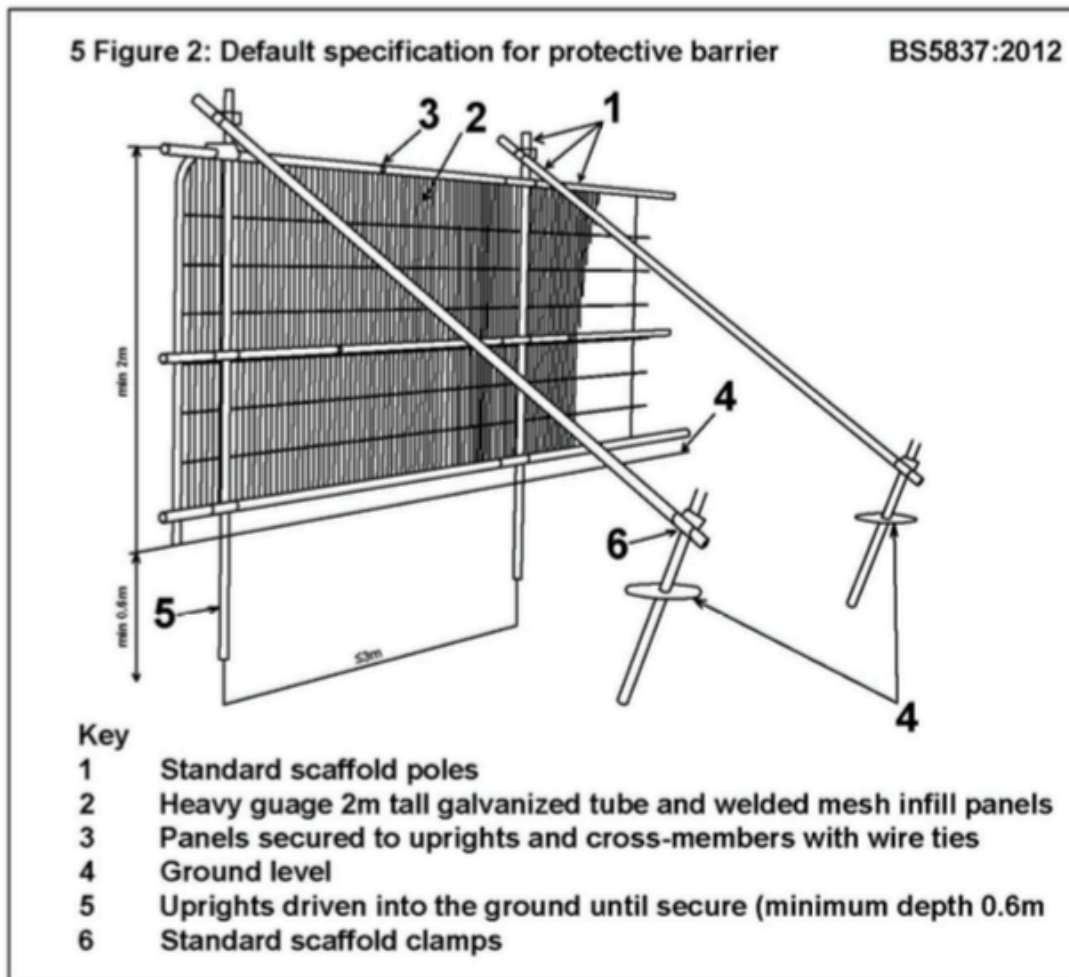

- 3.1.6. Once the barrier is installed, all-weather warning signs are to be placed at 3m intervals to ensure that all personnel are aware of the restrictions that apply to the cordoned off area, similar to those shown below and attached in Appendix 3.



- 3.1.7. No work shall commence until the protective barrier meets all requirements and has been confirmed by a suitably qualified arboriculturalist.

### 3.2. Protective barrier during construction

- 3.2.1. No operations shall take place which require the removal of part of the protective barrier without prior agreement with the Local Planning Authority.
- 3.2.2. The protective barrier must be inspected for faults or damage by the site manager or a responsible named person on a regular basis and a written record kept. Any faults or defects must be repaired or replaced as soon as it is reasonably practicable.

### 3.3. Removal of the protective barrier

- 3.3.1. When the development phase is complete and the site machinery has been removed, the Local Planning Authority should be invited to inspect the site to give approval for the removal of the protective barrier.
- 3.3.2. When this approval has been given the protective barrier can be dismantled and removed from site.



## **4. Construction phase**

### **4.1. Demolition works**

- 4.1.1. It is proposed to remove the soil in order to provide a ground retaining walls adjacent to the RPA's to the south and east side of the site. The removal of the existing soil must be carried out cautiously. The use of heavy machinery will only be permitted at the lower level of the existing hard standing and not on the higher level of retained ground levels.
- 4.1.2. Only hand tools are permitted when removing the soil from areas adjacent to the trees.
- 4.1.3. When the soil is to be removed to create the retaining walls and garage sub-base, where possible these should be dug out in a direction away from the protective barrier fencing and trees.
- 4.1.4. No waste materials or soil are to be stored within the protective barrier area.

## **Appendices**



Figure 2 Default specification for protective barrier

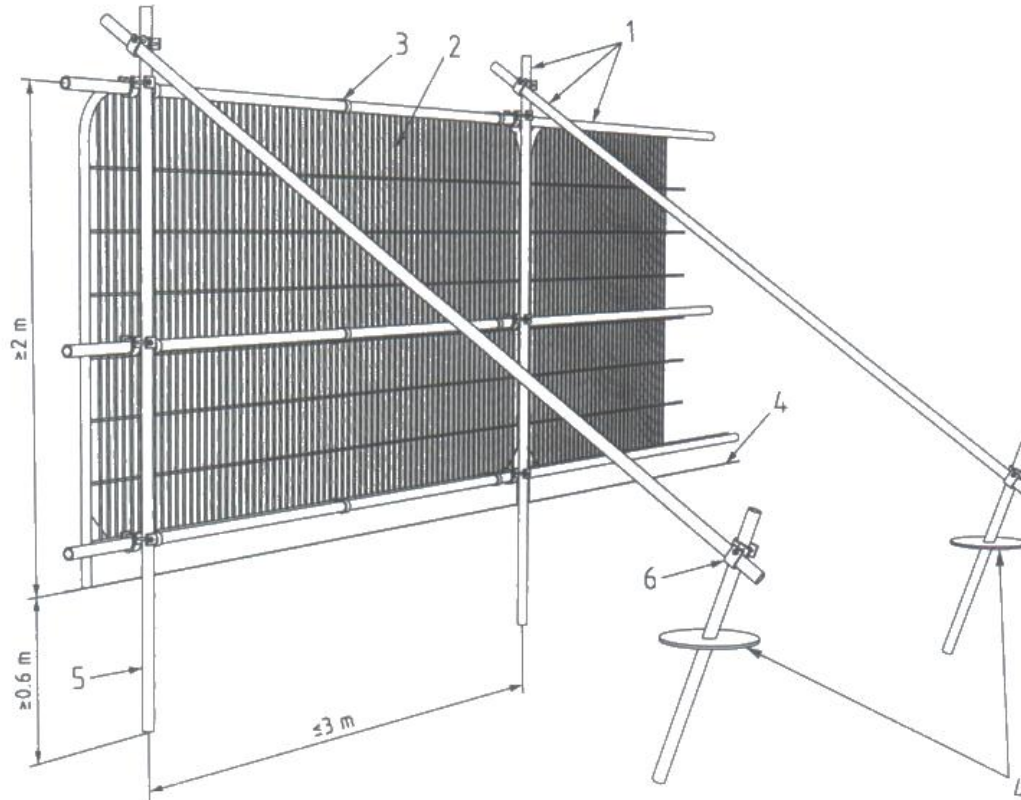

**Key**

- 1 Standard scaffold poles
- 2 Heavy gauge 2 m tall galvanized tube and welded mesh infill panels
- 3 Panels secured to uprights and cross-members with wire ties
- 4 Ground level
- 5 Uprights driven into the ground until secure (minimum depth 0.6 m)
- 6 Standard scaffold clamps

Figure 2: Protective Barrier to BS 5837: 2012

Figure 3 Examples of above-ground stabilizing systems

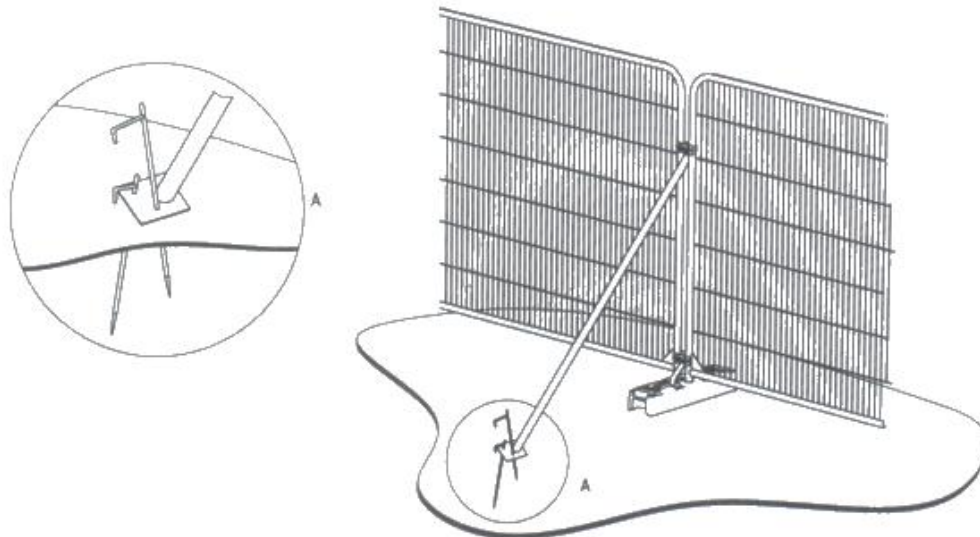

a) Stabilizer strut with base plate secured with ground pins

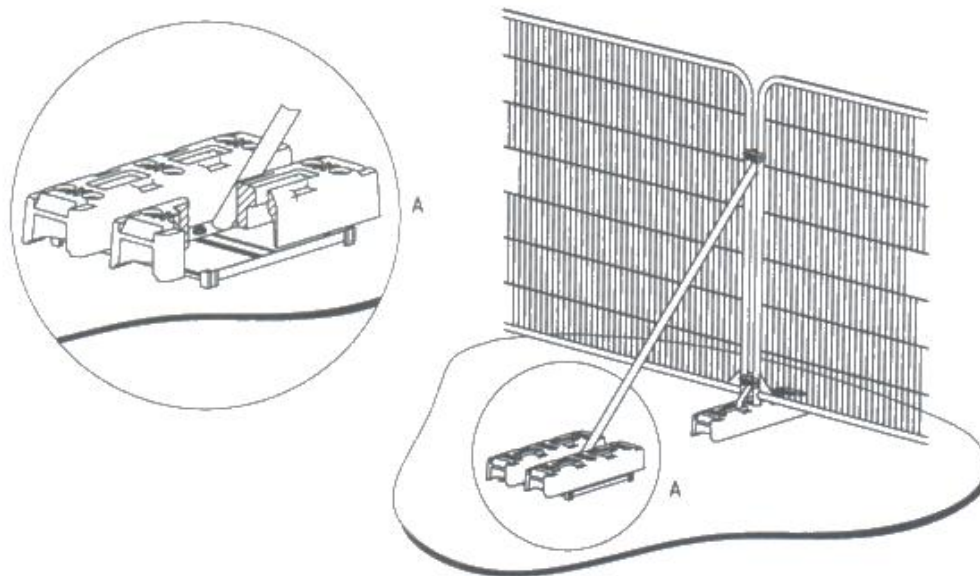

b) Stabilizer strut mounted on block tray

Figure 3 (a/b): Examples of above-ground stabilisation system.

**Appendix 3 – All-weather warning signs to be placed at 3m intervals along the Protective Barrier Fencing forming the CEZ.**



**CONSTRUCTION EXCLUSION ZONE**

**BARRIER FENCE MUST NOT BE MOVED**

**THE FOLLOWING IS PROHIBITED WITHIN THE  
PROTECTED AREA**

**No excavation, mechanical or otherwise**

**No adjustment to ground levels**

**No storage of plant or material**

**No storage or handling of any chemicals**

**No vehicular access**

**No fires**





**PROTECTIVE FENCING. THIS  
FENCING MUST BE  
MAINTAINED IN ACCORDANCE  
WITH THE APPROVED PLANS  
AND DRAWINGS FOR THIS  
DEVELOPMENT.**