

Issue: **PLANNING CONDITIONS**

Revision:

REFUSE AND RECYCLING TO BE STORED WITHIN APPROPRIATE KITCHEN BINS WITH WEEKLY KERBSIDE COLLECTION.

Due to site and building restrictions, it is not possible to accommodate a refuse/recycling store to the ground floor. As such, it is proposed that the flats are provided with appropriate bins within the kitchens and single use container collection is adopted.

RECYCLING : 91L

VAUTH-SAGEL VS ENVI SPACE 91L
XX PRO D 600-3

Included are 2 x 35L buckets and 1 x 21L bucket

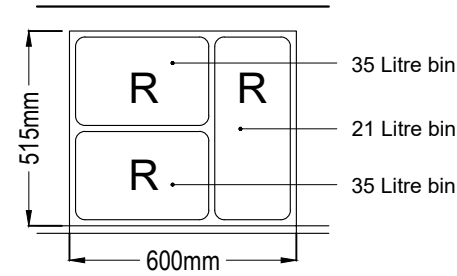

R: Recyclable Materials

Plan - Scale 1:20

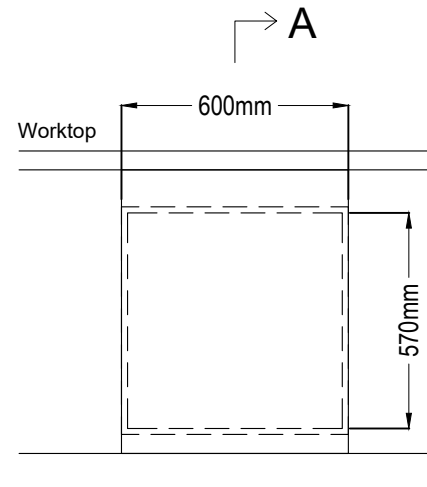

Elevation - Scale 1:20

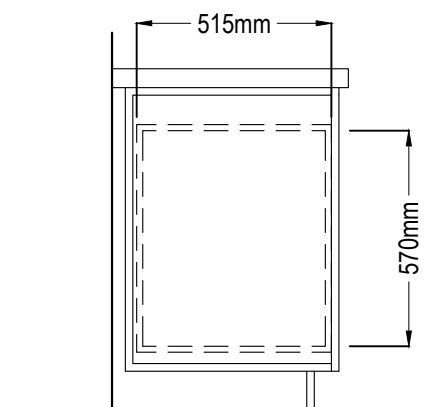

Section AA - Scale 1:20

General Waste: 84L

WESCO PULLBOY-Z 84L
RECYCLER 827642-11

Included are 2 x 42L buckets

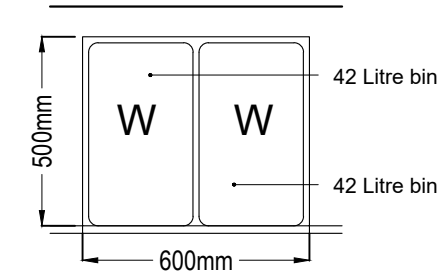

W: General Waste

Plan - Scale 1:20

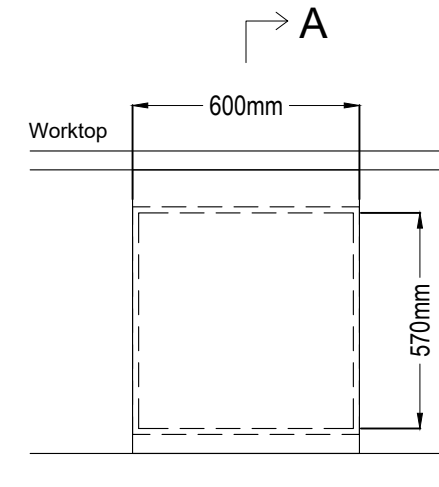

Elevation - Scale 1:20

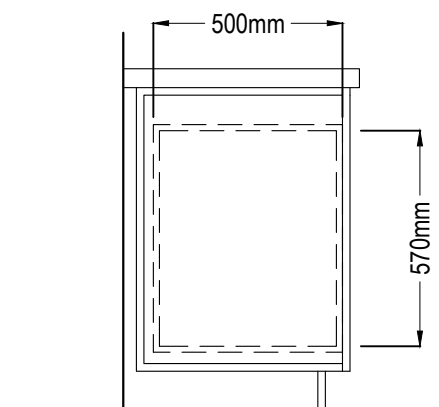

Section AA - Scale 1:20

Site Location Plan - 1:500

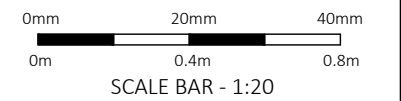

CG ARCHITECTS

36 Cannon Hill, London, N14 6LG
Tel: 020 8449 5100 | Fax: 020 8449 5170

Client: Arima Properties Ltd.

Site: 119-121 High Street
Barnet
EN5 5UZ

Title: Refuse/Recycling Details for
Discharge of Planning Condition 4

Scale: As noted @ A3	Drawn: DD	Chkd: CG
Date: Feb. 2024	Rev.:	#
Drg. No. 1670-33		