

The use of this data/drawing by the recipient acts as an agreement of the following statements. All drawings are based upon site information supplied by third parties/sub contractors and as such their accuracy cannot be guaranteed. All features are approximate and subject to clarification by a detailed topographical survey, statutory service enquiries and confirmation of the legal boundaries. Check all dimensions on site. Drawings printed on mediums such as paper are not to be relied upon for scaling purposes as dimensional inaccuracy occur resulting from changes in environmental conditions. Use figured dimensions in all cases. All dimensions to be in metric standards unless stated otherwise.

Property of Sanderson Weatherall, 25 Wellington Street, Leeds. LS1 4WG. All rights of the copyright holders reserved. Unauthorised copying, hiring, lending of this data for financial or commercial gain prohibited

Revision : 01 First Issue Drawn : EEy Date : 30/01/24

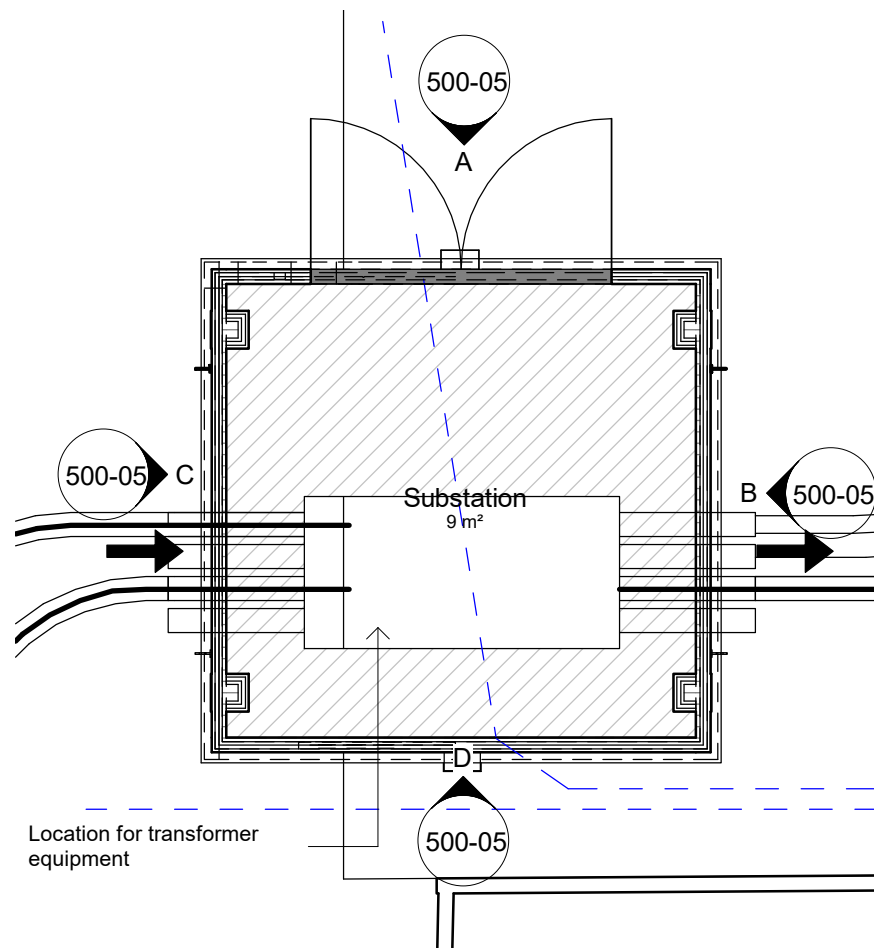

HV substation, as proposed  
1 : 50

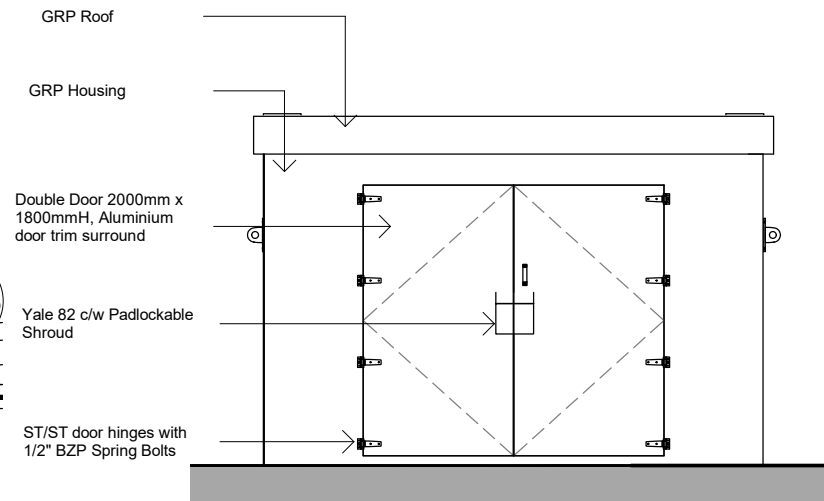
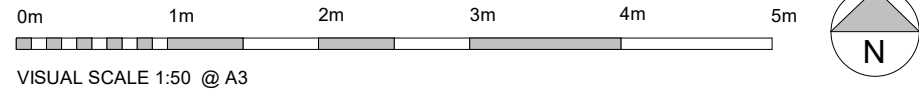

A Substation, front elevation, as proposed  
1 : 50

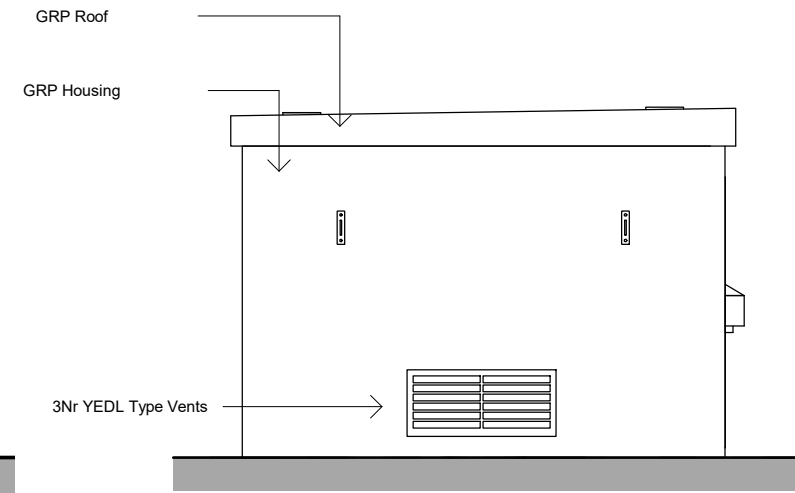

B Substation, East elevation, as proposed  
1 : 50

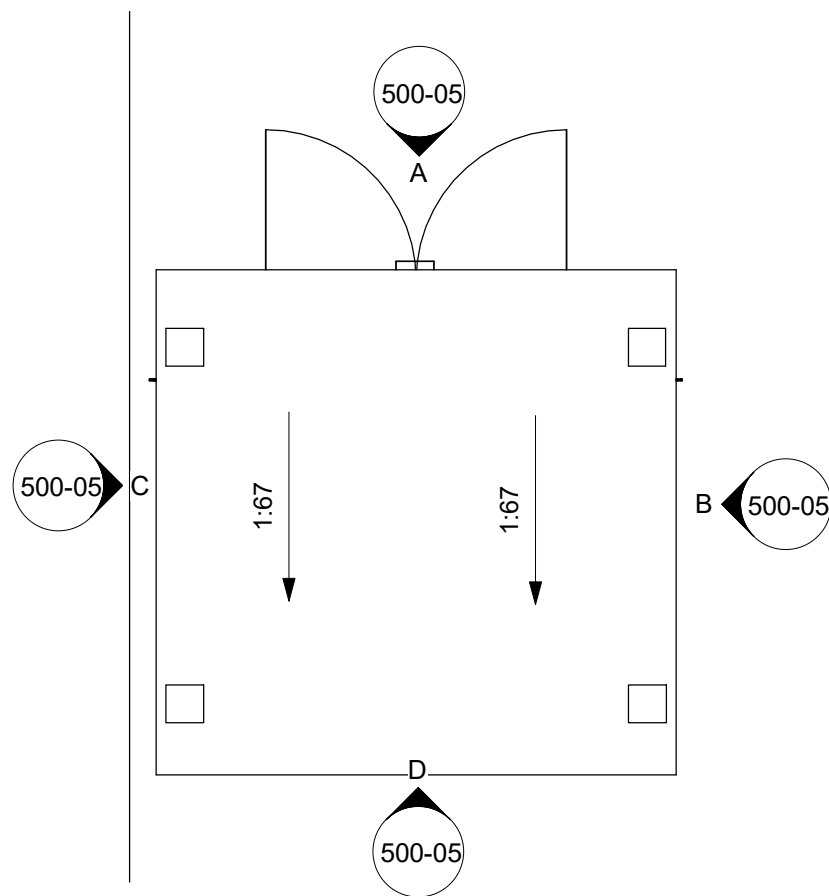

HV substation, roof plan, as proposed  
1 : 50

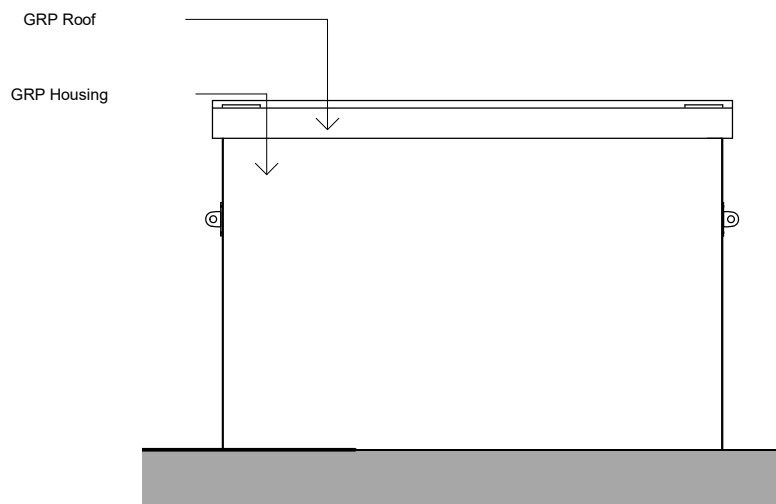

D Substation rear elevation, as proposed  
1 : 50

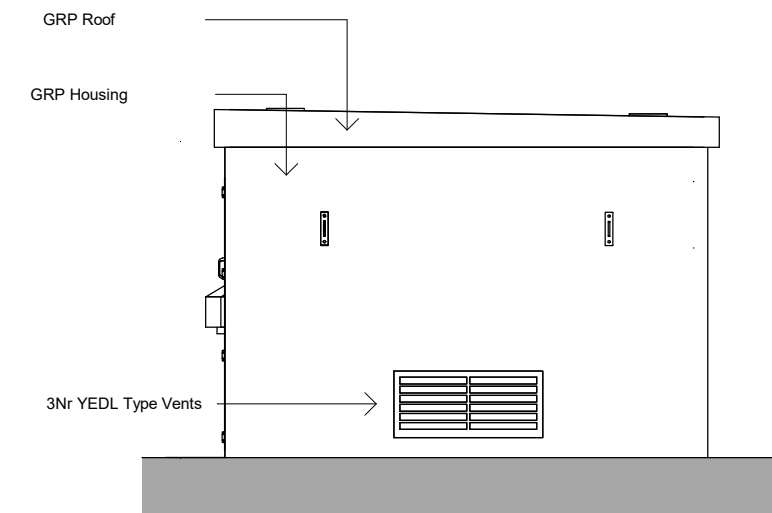

C Substation, West elevation, as proposed  
1 : 50



Client :  
**Roberts Mart**  
Address :  
Thornes Farm Way, Leeds. LS9 0AN.

Drawing :  
**Substation, enlarged plans and elevations, as proposed**

Job Ref : <b>171389</b>	Dwg No : <b>500-05</b>	Revision : <b>01</b>
Drawn : <b>EEy</b>	Checked : <b>SRi</b>	Scale : @A3 <b>1 : 50</b>

Status :  
**PLANNING**