

NOTES: THIS DRAWING IS THE COPYRIGHT OF MODH DESIGN LTD. IT MAY NOT BE COPIED, ALTERED OR REPRODUCED WITHOUT WRITTEN AUTHORITY. THE USE OF THIS DRAWING BY THIRD PARTIES IS ENTIRELY AT THEIR OWN RISK.

THE DRAWING MUST NOT BE SCALED. ALL LEVELS AND DIMENSIONS MUST BE CHECKED ON SITE. FIGURED DIMENSIONS MUST BE CHECKED ON SITE. FIGURED DIMENSIONS SHOULD BE TAKEN IN PREFERENCE TO SCALED DIMENSIONS.

THIS DRAWING HAS BEEN TRACED FROM RECEIVED PDF PLANS PROVIDED BY THE CLIENT. IT IS THE RESPONSIBILITY OF CONSULTANTS, CONTRACTORS AND SUB-CONTRACTORS TO ENSURE ALL DIMENSIONS ARE CHECKED & CONFIRMED ON SITE PRIOR TO ANY WORKS COMMENCING. FABRICATION, ORDERING OF PRODUCTS AND INSTALLATION MATERIALS TO BE MARINE GRADE 316.

**FOR PLANNING APPLICATION
SUBMISSION PURPOSES ONLY**

ALL PROPOSED METAL & IRONWORKERY TO BE MARINE GRADE 316.

EXTERIOR LIGHTING TO FOLLOW AONB GUIDANCE. REPLACEMENT OR PROPOSED LIGHTS TO BE HOODED, RECESSED OR BENEATH OVERHANG WITH LIGHT FOCUSING DOWNWARDS AS NOT TO IMPEDE ON DARK SKIES.

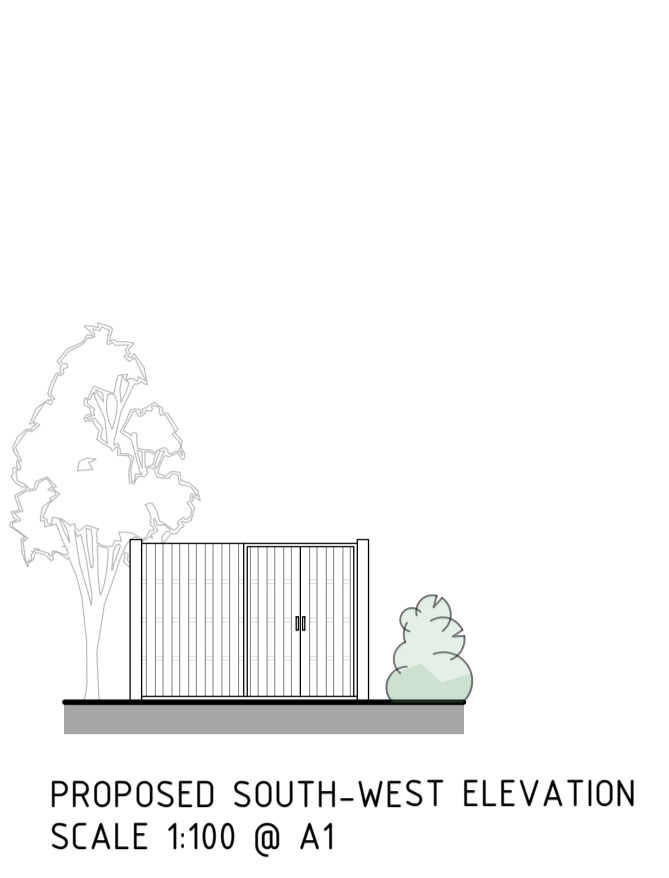
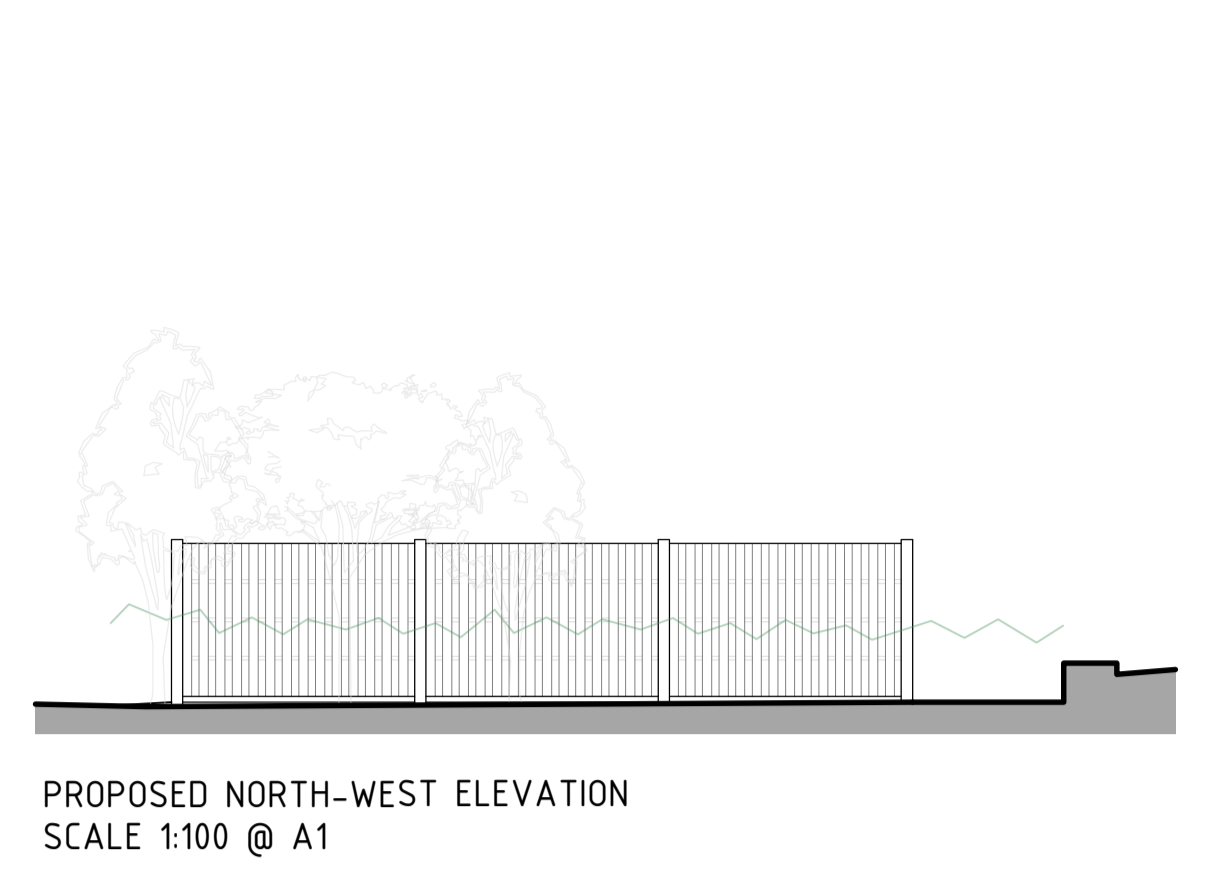
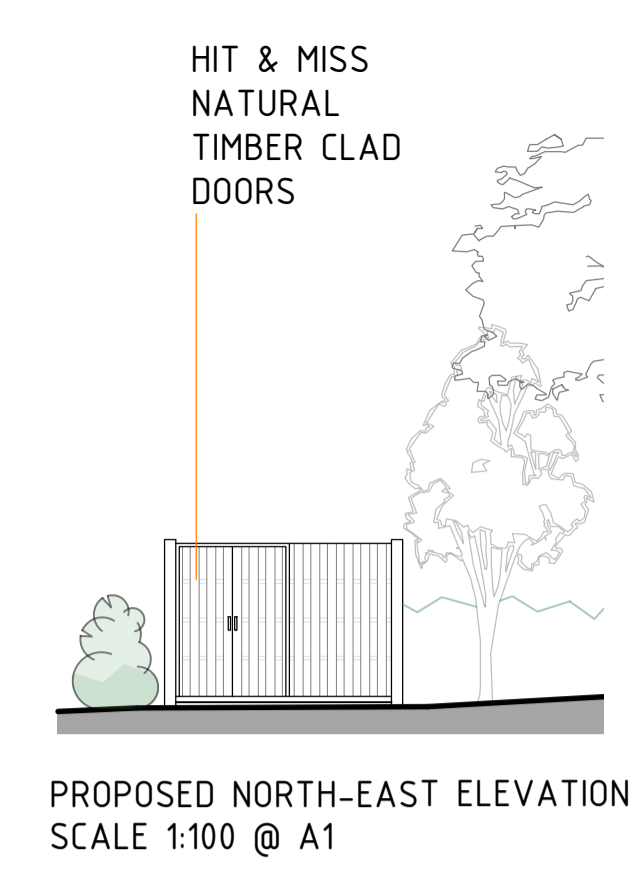
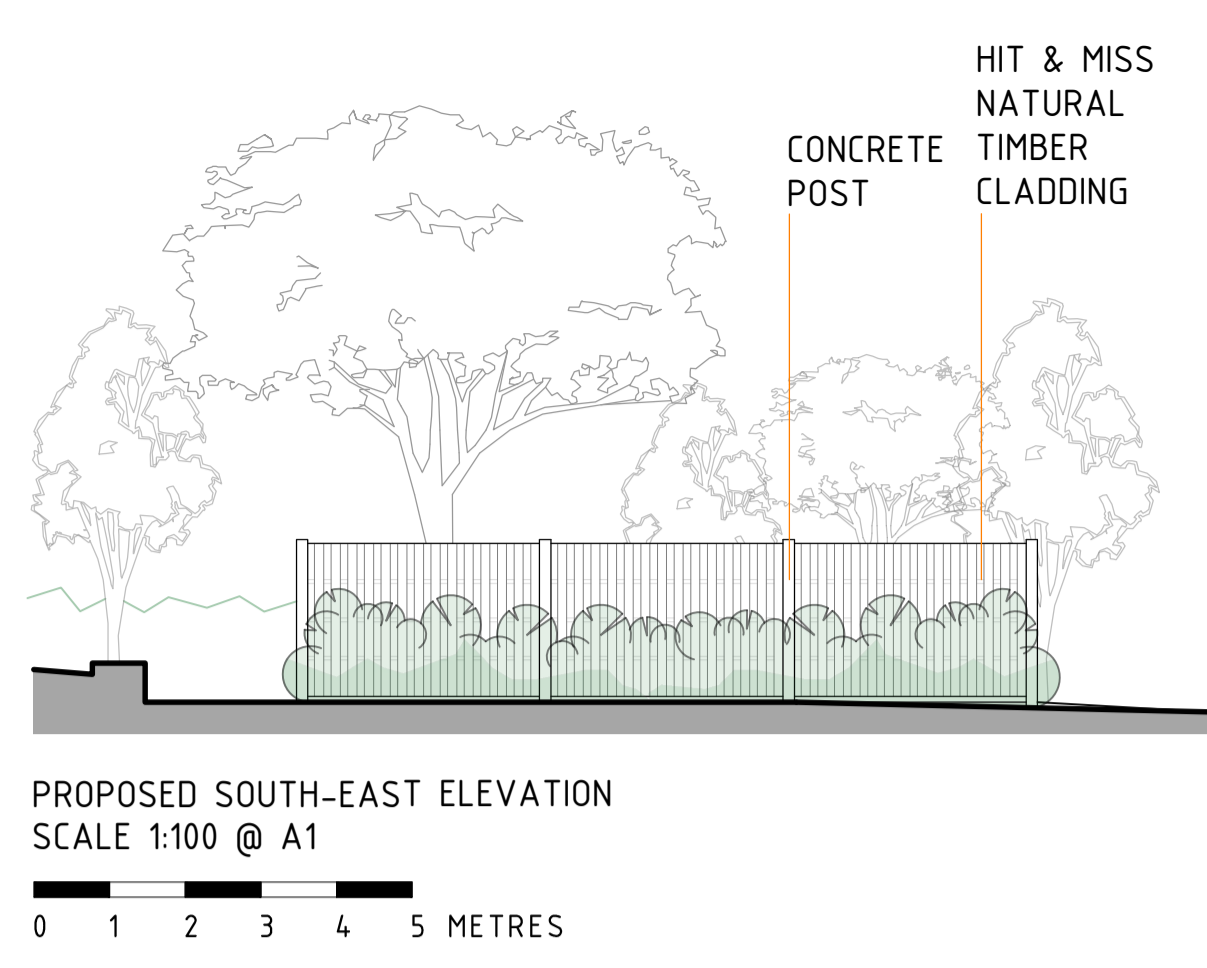

PROPOSED LONG STAY BIKE:
10 SPACE AMAZON ECO CYCLE SHELTER, IN GALVANISED METAL WITH TIMBER CLADDING AND TIMBER CLAD DOORS, METAL ROOF. 10 X SHEFFIELD STANDS INTERNALLY. DOORS SHOWN OPEN ON IMAGE BELOW
W4.1M X D2.1M X H2.1M

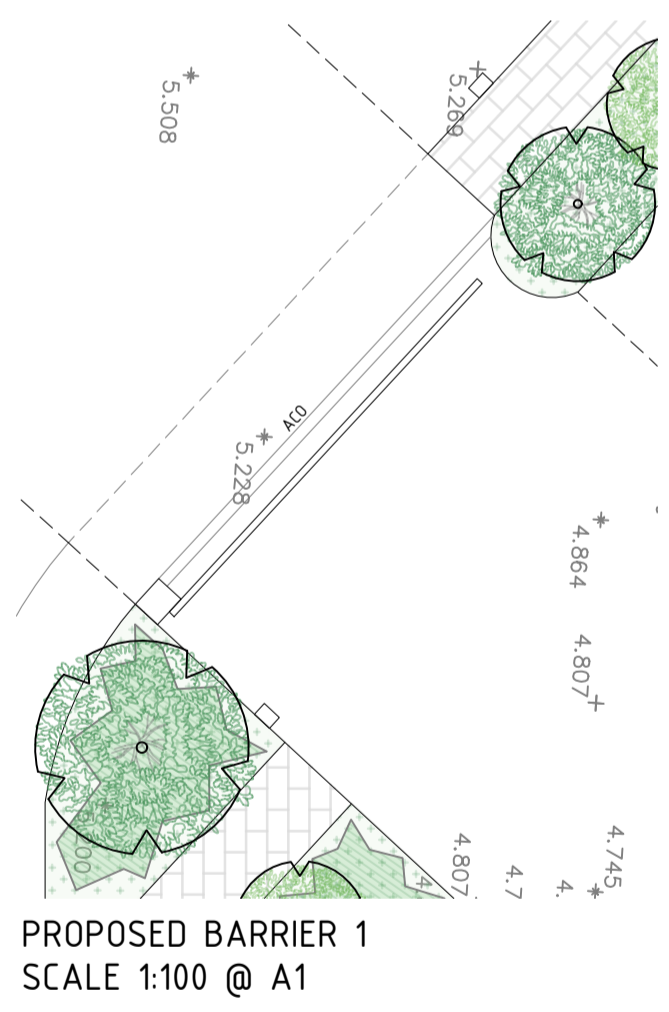
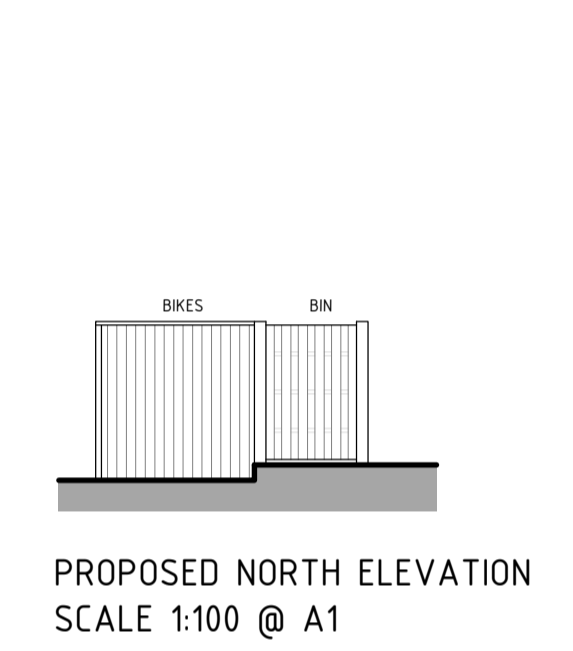
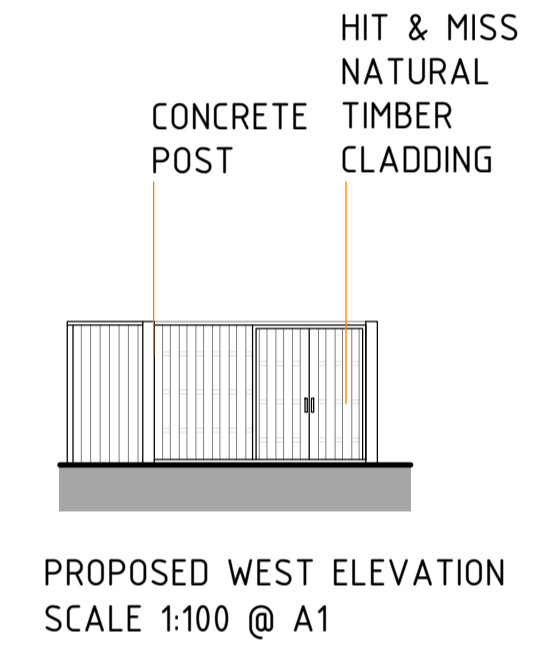
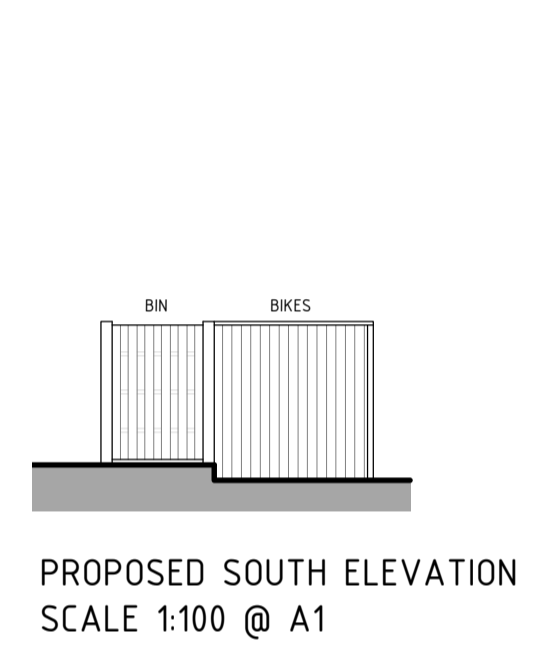

PROPOSED BARRIER 1:
BFT, 6.0 MTR MICHELANGELO WITH 2 X BFT CELLCOM PRIME INTERCOM ON ALUMINIUM POST,
- RAL 7016 ANTHRACITE GREY CABINET ON CONCRETE BASE
- ALUMINIUM BOOM WITH A FIXED REST

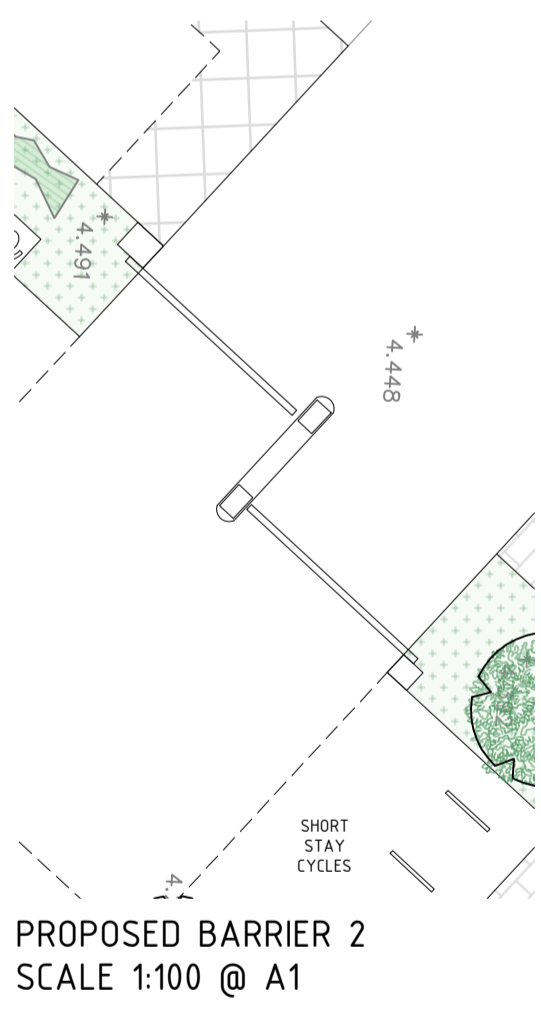
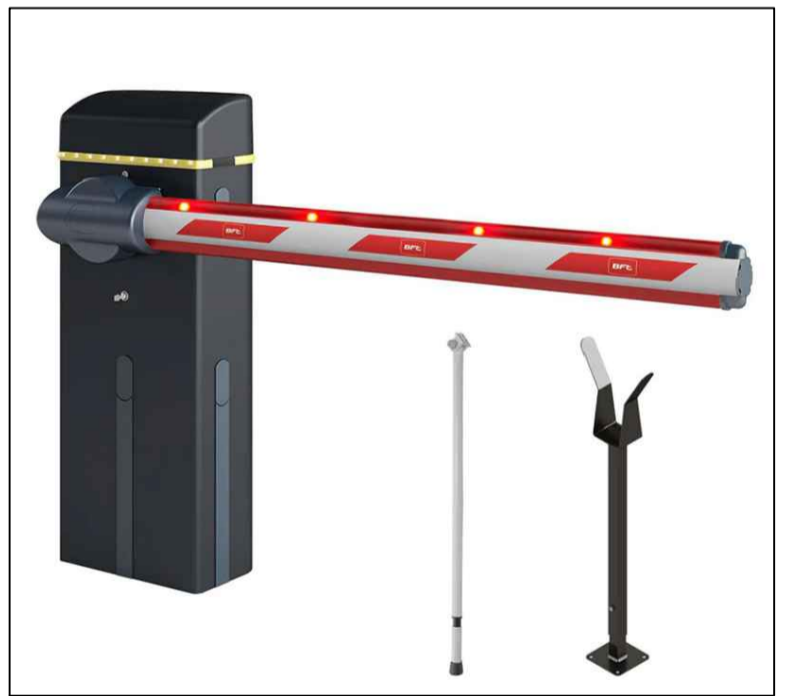
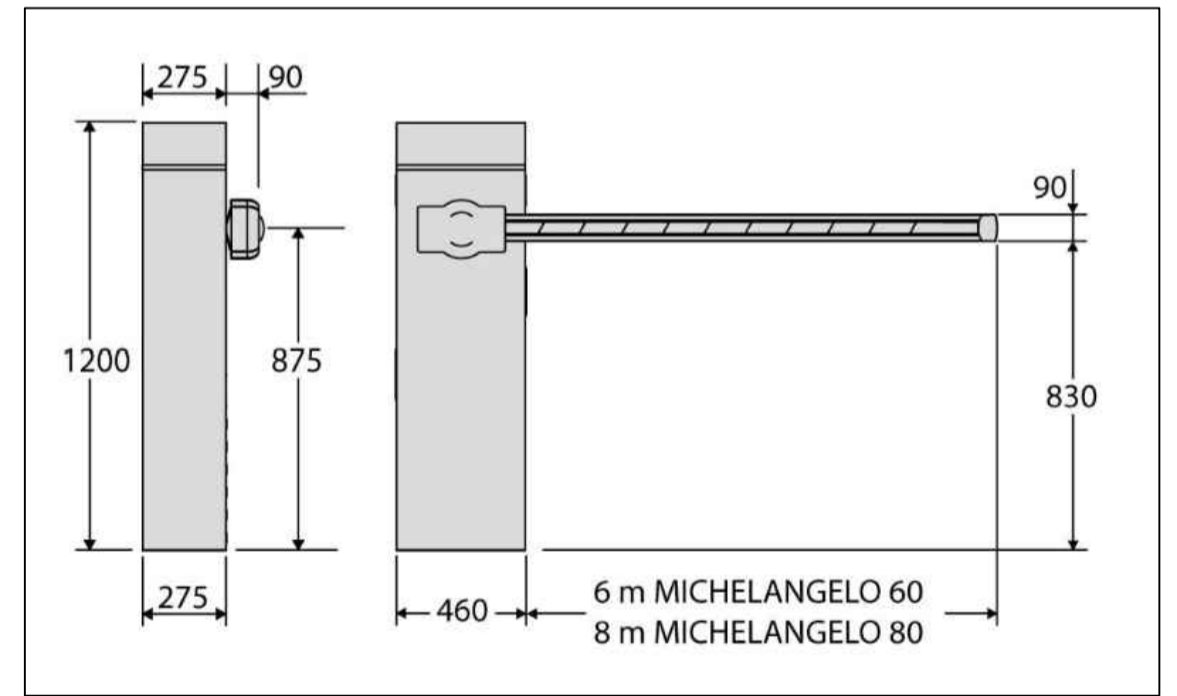

PROPOSED BARRIER 2:
METRIC, MICRO TERMINAL WITH MOUNTING PLATE ON ALUMINIUM POST,
2 X BFT 3.0 MTR GIOTTO BARRIERS MOUNTED ON CONCRETE BASE:
- RAL 7016 ANTHRACITE GREY CABINET

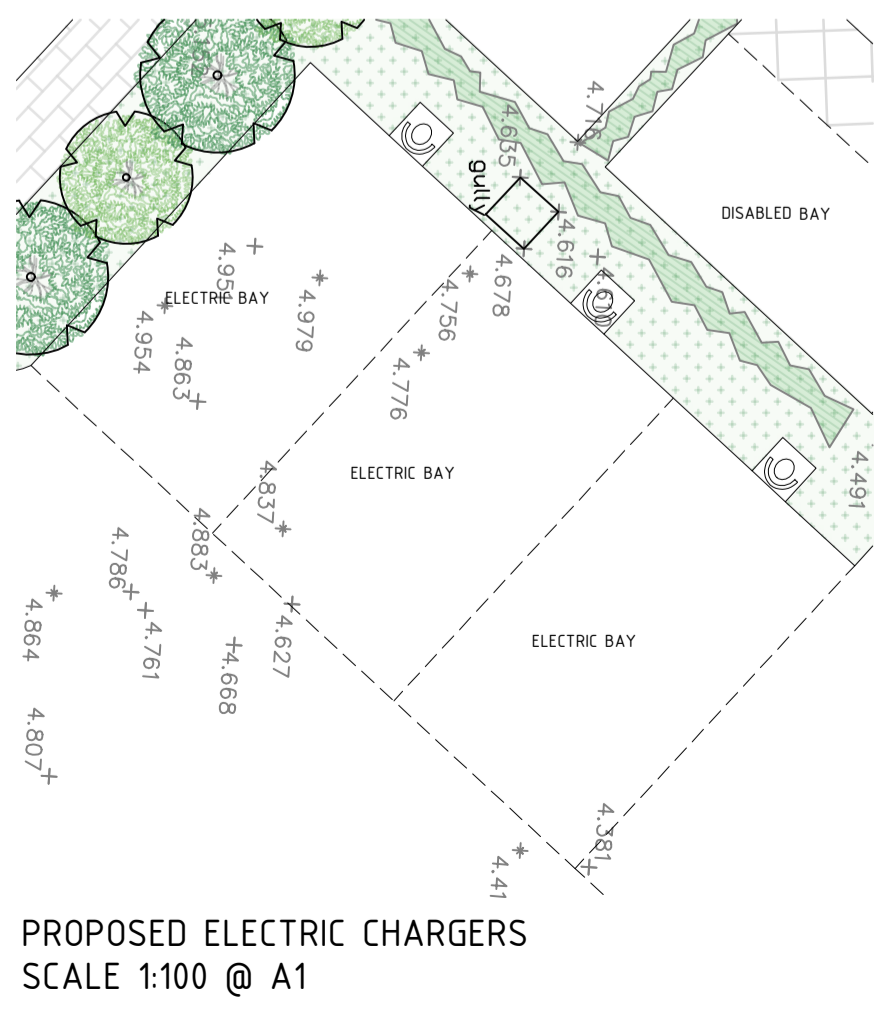
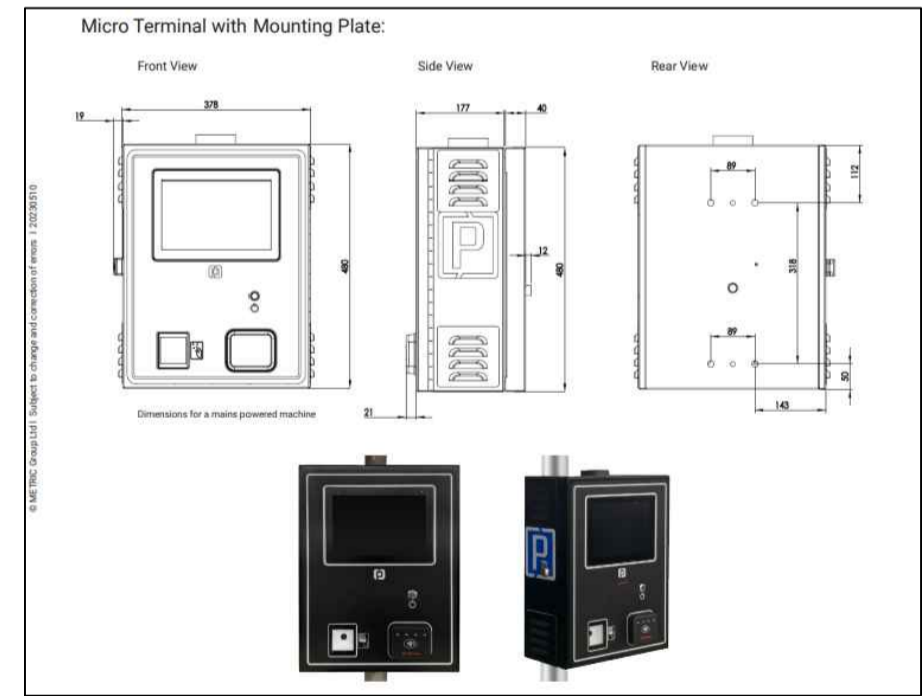
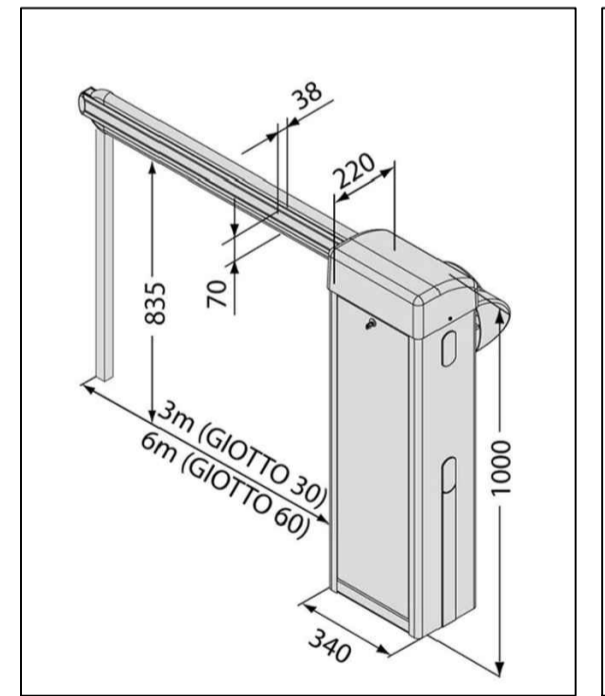

PROPOSED CHARGERS: 3 X POD POINT TWIN CHARGER, RAL 9005 WITH GUARD RAIL
HEIGHT: 1330MM
WIDTH: 241MM
DEPTH: 295MM

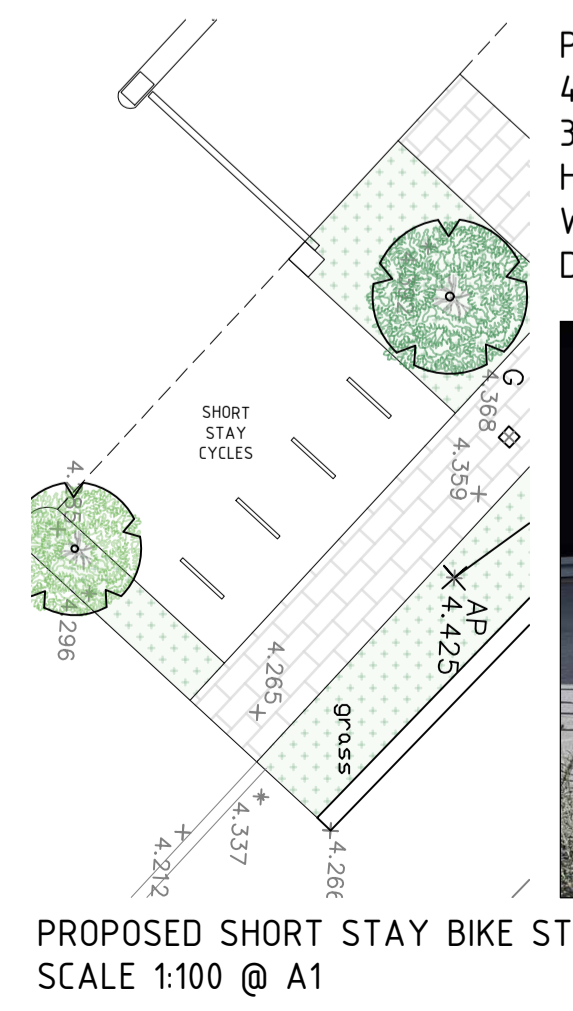

PROPOSED SHORT STAY BIKES:
4 X SHEFFIELD BIKE STANDS,
316 GRADE STAINLESS STEEL
HEIGHT: 750MM
WIDTH: 750MM
DEPTH: 50MM

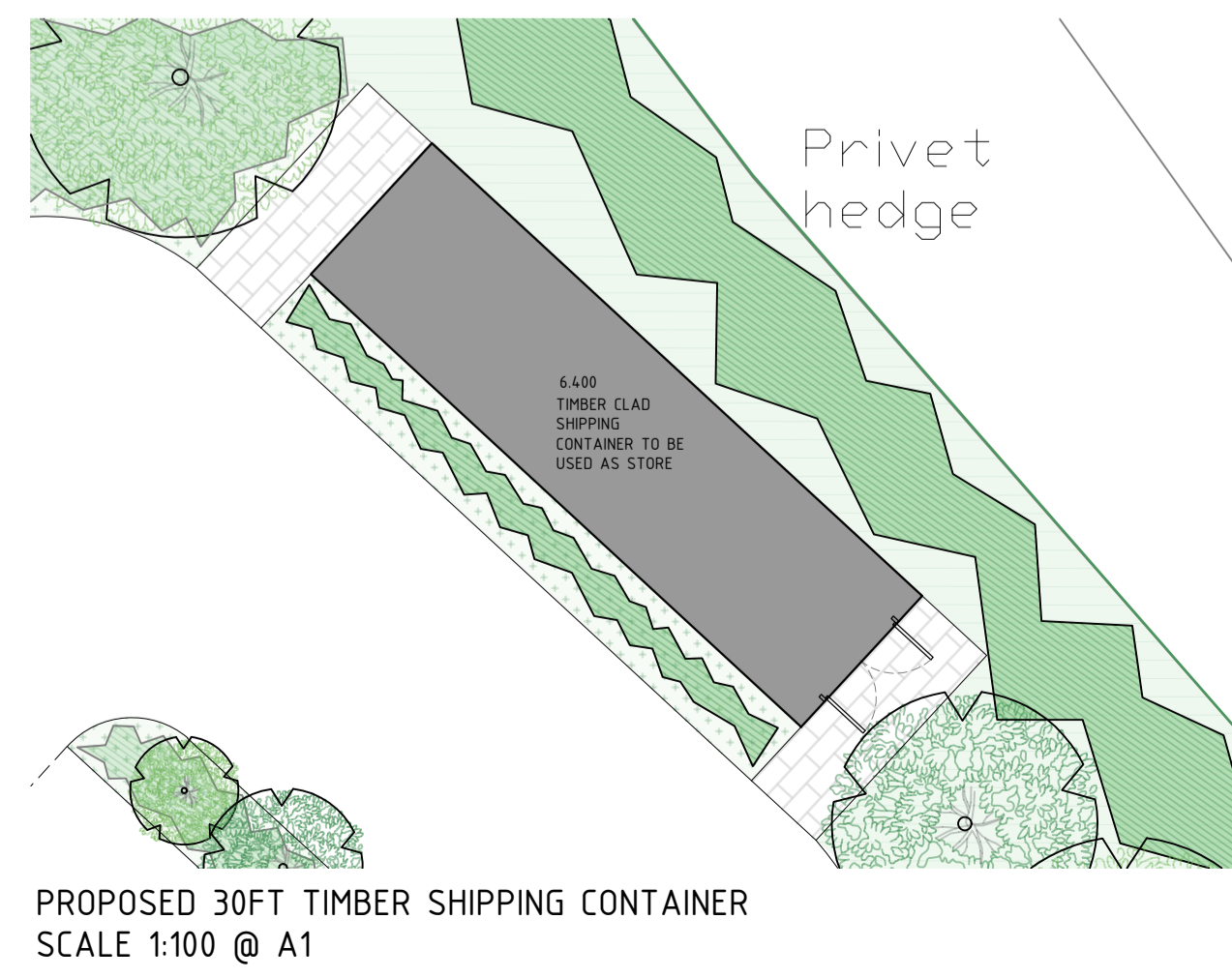
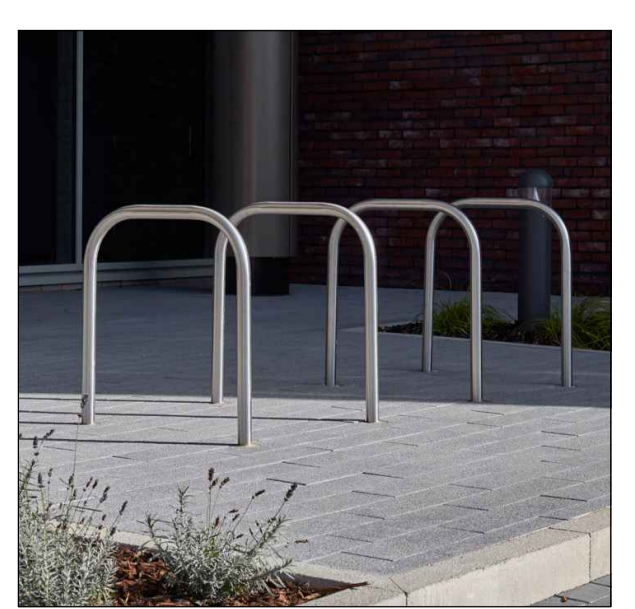

PROPOSED STORE:
30FT TIMBER CLAD SHIPPING CONTAINER WITH PLANTING SURROUNDING ELEVATIONS
HEIGHT: 2.6M
WIDTH: 2.5M
DEPTH: 9.2M



REVISIONS: DATE: NOTE:



A | STUDIO 1, NEW BARN FARM, SUN HILL, CALBOURNE, IOW PO30 4JA
T | 01983 555051
W | WWW.MODHDESIGN.CO.UK
E | HELLO@MODHDESIGN.CO.UK

CLIENT:
AZK LEISURE LLP

PROJECT:
PROPOSED SPA BUILDING & CAR PARK ALTERATIONS AT THE ALBION HOTEL, FRESHWATER BAY, FRESHWATER PO40 9RA

DRAWING TITLE:
PROPOSED DETAILS

SCALE: 1:100@A1 OR 1:200@A3 DATE: FEB 24 DRAWN: EF

STAGE: PLANNING APPLICATION CHECKED BY: CC

JOB NUMBER: MDA223 DRAWING NUMBER: PL 210 REVISION: .